

MAXIM

MAX1703 Evaluation Kit

Evaluates: MAX1703

General Description

The MAX1703 evaluation kit (EV kit) provides a regulated 5.0V output while operating on input voltages as low as 1.2V. The input may be a DC source or a 1 to 3-cell battery. Efficiency is up to 95%, and output loads are up to 1A.

The kit, which uses surface-mount components, is fully assembled and tested for quick evaluation. Jumpers are provided to select the output voltage, switching mode, and shutdown control.

Component List

DESIGNATION	QTY	DESCRIPTION
C1, C2, C3	3	0.22 μ F, 25V ceramic capacitors
C4	1	100 μ F, 10V low-ESR tantalum capacitor: AVX TPSD107M010R0100 or Sprague 593D107X0010D
C5, C6	2	220 μ F, 10V low-ESR tantalum capacitors AVX TPSE227M010R0100 or Sprague 593D227X0010E
C7	1	Not installed, optional user capacitor
D1	1	0.5A, 20V Schottky diode Motorola MBR0520L
L1	1	4.7 μ H, 3.2A power inductor Sumida CDH74-4R7 Coilcraft DO3316-4R7, Coiltronics UP2B-4R7 or Sumida CDRH 104, 4746-JPS-007
J1, J2	2	3-pin jumpers
J3, J4	2	2-pin jumpers
R1, R7, R5	3	100k Ω 1% resistors
R2, R4, R6	0	Not installed, user-selected resistor
R3	1	10 Ω , 5% resistor
R8, R9	2	100k Ω , 5% resistors
R10, R11	2	1M Ω , 5% resistors
U1	1	MAX1703ESE
None	4	Shunts
None	1	3.40" X 2.40" printed circuit board
None	1	MAX1703 data sheet

Features

- ◆ 5.0V Output
- ◆ 1A Output Current
- ◆ 1.2V to 5.5V Input
- ◆ Up to 95% Efficiency
- ◆ 0.1 μ A Shutdown Current
- ◆ 300kHz PWM Operation
- ◆ Optional Low-Power Mode
- ◆ Small Surface-Mount Components

Ordering Information

PART	TEMP. RANGE	PIN-PACKAGE
MAX1703EVKIT	0°C to +70°C	16 Narrow SO

Component Suppliers

SUPPLIER	PHONE	FAX
AVX	(803) 946-0690	(803) 626-3123
Coilcraft	(847) 639-6400	(847) 639-1469
Coiltronics	(561) 241-7876	(561) 241-9339
Motorola	(602) 244-5303	(602) 244-4015
Sprague	(603) 224-1961	(603) 224-1430
Sumida	(847) 956-0666	(847) 956-0702

MAX1703 Evaluation Kit

Quick Start

The MAX1703 EV kit is shipped fully assembled and tested. Follow these steps to verify board operation. **Do not turn on the power supply until all connections are completed.**

- 1) Verify that the shunts are connected as listed in Table 2 for a 5V output.
- 2) Connect a 1.2V to 5.5V supply to the VIN pad. The ground connects to the GND pad.
- 3) Connect a voltmeter to the VOUT pad.
- 4) Turn on the power, and verify that the output voltage is 5V.
- 5) Connect a load if any.

Detailed Description

Jumper Selections

Four jumpers on the printed circuit board allow user selection of several configurations. Table 1 lists the jumpers and their functions. Table 2 lists the jumper positions when the board is set for normal 5V output operation.

Component Selection

The final circuit performance is determined by the quality of the components surrounding the MAX1703. The

power inductor must not saturate at the 3.2A peak current produced by MAX1703. All inductors listed in the component list have high current ratings and low coil resistance.

The input and output capacitors must have low equivalent-series resistance (ESR) to handle the high peak currents found in switching regulators. Low ESR is especially critical in low-voltage circuits to reduce the AC voltage across the capacitors. A higher ESR on the output capacitor will increase the output ripple. Consider using parallel capacitors to reduce the total ESR if the application requires lower output ripple.

A low-ESR input capacitor must be located physically close to the inductor. A Schottky diode is used for the lower forward voltage drop as well as the fast switching characteristic. The diode selected for the evaluation board was selected for its small size. The Schottky diode must be connected between LX and POUT as close to the IC as possible.

A separate low-noise ground plane connects pin 5 to the reference and signal grounds. This low-noise ground plane is then connected to the power ground plane at the two PGND pins (Figure 4).

Table 1. Jumper Functions

JUMPER	SHUNT POSITION	PIN CONNECTION	MAX1703 OPERATION
J1	1 & 2	$\overline{\text{ON}}$ connected to GND	The MAX1703 is enabled.
	2 & 3	$\overline{\text{ON}}$ connected to VOUT	The MAX1703 is disabled.
	Open	$\overline{\text{ON}}$ is not controlled by the board.	$\overline{\text{ON}}$ must be driven by a signal connected to the $\overline{\text{ON}}$ pad.
J2	1 & 2	CLK/SEL pin connected to GND	Low-power mode, the MAX1703 operates in the PFM mode.
	2 & 3	CLK/SEL pin connected to VOUT	High-power mode, the MAX1703 operates in the PWM mode.
	Open	CLK/SEL connected to CLK/SEL pad	CLK/SEL pin can be driven by an external source to select the power mode or a 200kHz to 400kHz signal to control the switching frequency.
J3	Shorted	FB pin connected to GND	VOUT preset to 5V.
	Open	FB pin connected to the resistor divider	Output voltage determined by the R4-R5 resistor divider. Note: A resistor must be installed in R4 to set the output voltage before removing the shunt.
J4	Shorted	VOUT connected to pull-up resistors	This jumper is necessary for normal circuit operation.
	Open	The pull-up resistors are disconnected	The J4 shunt should only be removed when testing the MAX1703 shutdown current.

MAX1703 Evaluation Kit

Evaluates: MAX1703

Table 2. Jumper Position for Normal 5.0V Operation

JUMPER	SHUNT POSITION	PIN CONNECTION	MAX1703 OPERATION
J1	1 & 2	$\overline{\text{ON}}$ pin connected to GND.	The MAX1703 is enabled.
J2	2 & 3	CLK/SEL pin connected to VOUT.	High-power mode; the MAX1703 operates in the PWM mode.
J3	Shorted	FB pin connected to GND.	VOUT is preset to 5V.
J4	Shorted	VOUT connected to the pull-up resistors.	This shunt is necessary for normal circuit operation.

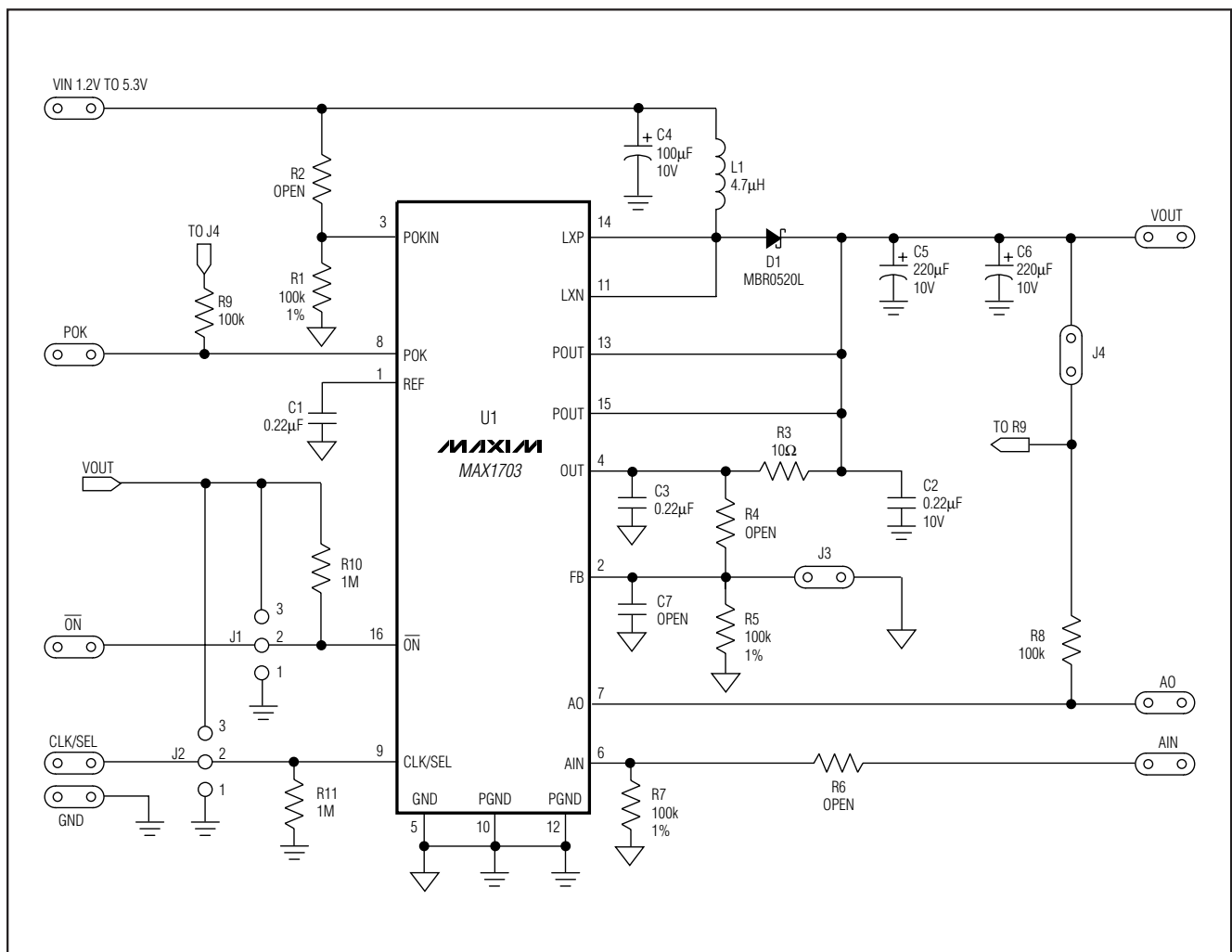

Figure 1. MAX1703 EV Kit Schematic

MAX1703 Evaluation Kit

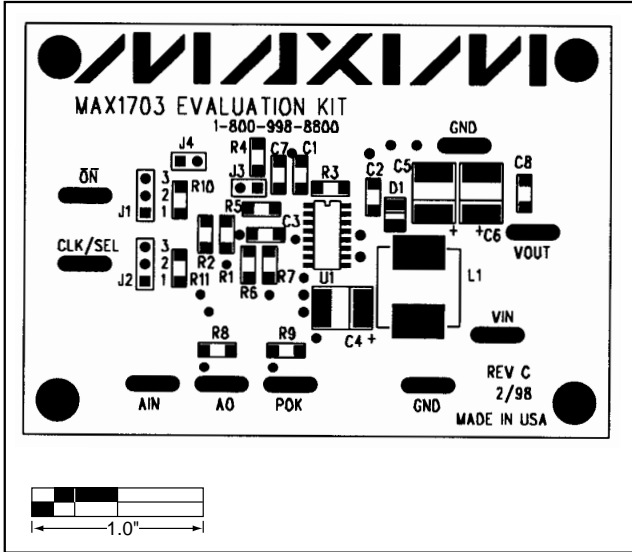

Figure 2. MAX1703 EV Kit Component Placement Guide

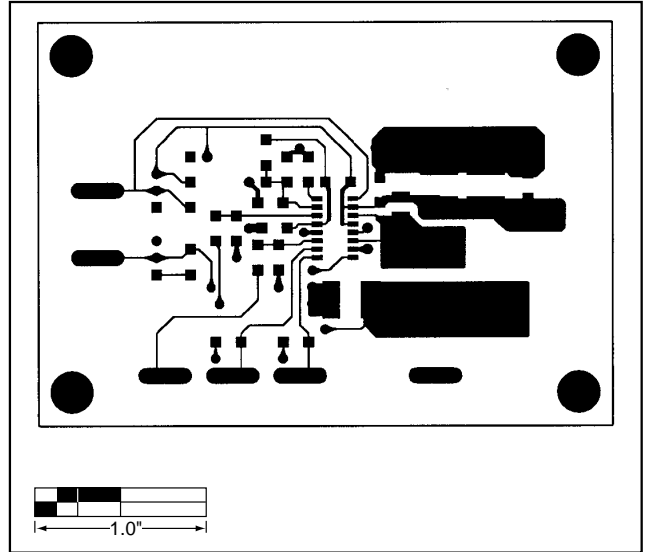

Figure 3. MAX1703 EV Kit PC Board Layout—Component Side

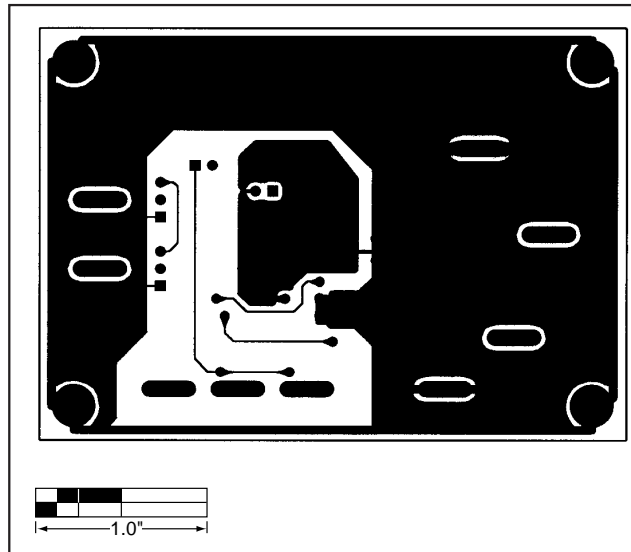

Figure 4. MAX1703EV Kit PC Board Layout—Solder Side

Maxim cannot assume responsibility for use of any circuitry other than circuitry entirely embodied in a Maxim product. No circuit patent licenses are implied. Maxim reserves the right to change the circuitry and specifications without notice at any time.

4 **Maxim Integrated Products, 120 San Gabriel Drive, Sunnyvale, CA 94086 408-737-7600**