

HIGH VOLTAGE HIGH SPEED POWER
SWITCHING TRANSISTOR

FEATURES

- * High hFE for Low base drive requirement
- * Suitable for half bridge light ballast Applications
- * Built-in Free-wheeling Diode makes it specially suitable for light ballast Applications
- * Well controlled storage-time spread for all range of hFE

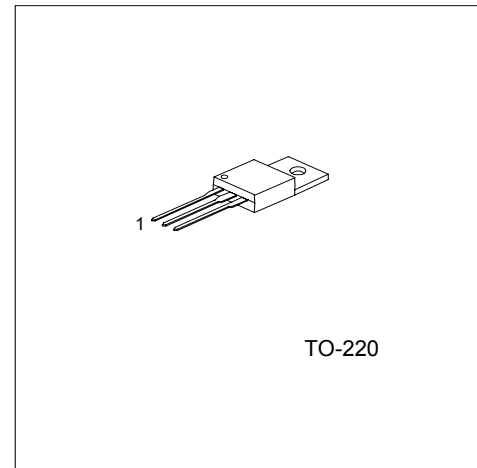

TO-220

1: Base 2: Collector 3: Emitter

*Pb-free plating product number: 2SC5305L

ABSOLUTE MAXIMUM RATINGS

(T_C=25°C, unless otherwise noted.)

PARAMETER	SYMBOL	RATINGS	UNIT
Collector Base Voltage	V _{CB0}	800	V
Collector Emitter Voltage	V _{CEO}	400	V
Emitter Base Voltage	V _{EBO}	12	V
Collector Current (DC)	I _C	5	A
Collector Current (Pulse)*	I _{CP}	10	A
Base Current (DC)	I _B	2	A
Base Current (Pulse)*	I _{BP}	4	A
Power Dissipation (T _C =25°C)	P _C	75	W
Junction Temperature	T _j	150	°C
Storage Temperature	T _{stg}	-65 ~ 150	°C

THERMAL CHARACTERISTICS

(T_C=25°C, unless otherwise noted.)

PARAMETER	SYMBOL	RATINGS	UNIT
Thermal Resistance			
Junction to Case	R _{θJC}	1.65	°C/W
Junction to Ambient	R _{θJA}	62.5	

ELECTRICAL CHARACTERISTICS

(T_C=25°C, unless otherwise noted.)

PARAMETER	SYMBOL	TEST CONDITIONS	MIN	TYP	MAX	UNIT
Collector-Base Breakdown Voltage	BV _{CBO}	I _C = 1mA, I _E = 0	800			V
Collector-Emitter Breakdown Voltage	BV _{CEO}	I _C = 5mA, I _B = 0	400			V
Emitter Cut-off Current	BV _{EBO}	I _E =1mA, I _C =0	12			V
Collector Cut-off Current	I _{CBO}	V _{CB} =500V, I _E =0			10	μA
Emitter Cut-off Current	I _{EBO}	V _{EB} = 9V, I _C = 0			10	μA
DC Current Gain	h _{FE1} h _{FE2}	V _{CE} =1V, I _C =0.8A	22			
		V _{CE} =1V, I _C =2A	8			
Collector-Emitter Saturation Voltage	V _{CE} (sat)	I _C =0.8A, I _B =0.08A			0.4	V
		I _C =2A, I _B =0.4A			0.5	V
Base-Emitter Saturation Voltage	V _{BE} (sat)	I _C =0.8A, I _B =0.08A			1.0	V
		I _C =2A, I _B =0.4A			1.0	V
Output Capacitance	C _{ob}	V _{CB} = 10V, f=1MHz			75	pF
Turn ON Time	t _{ON}	V _{CC} =300V, I _C =2A			150	ns
Storage Time	t _{STG}	I _{B1} = 0.4A, I _{B2} =-1A R _L = 150Ω			2	μs
Fall Time	t _F				0.2	μs
Storage Time	t _{STG}		V _{CC} =15V, V _Z =300V			2.25
Fall Time	t _F	I _C = 2A, I _{B1} = 0.4A			150	ns
		I _{B2} = -0.4A, L _C =200μH				
Diode Forward Voltage	V _F	I _F = 1A			1.5	V
		I _F = 2A			1.6	V
Reverse recovery time* (di/dt =10A/μs)	t _{rr}	I _F = 0.4A		800		ns
		I _F = 1A		1.4		μs
		I _F = 2A		1.9		μs

*Pulse Test : Pulse Width=5mS, Duty cycles ≤ 10%

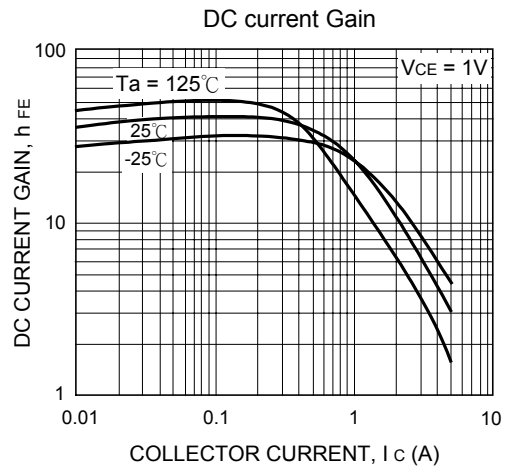
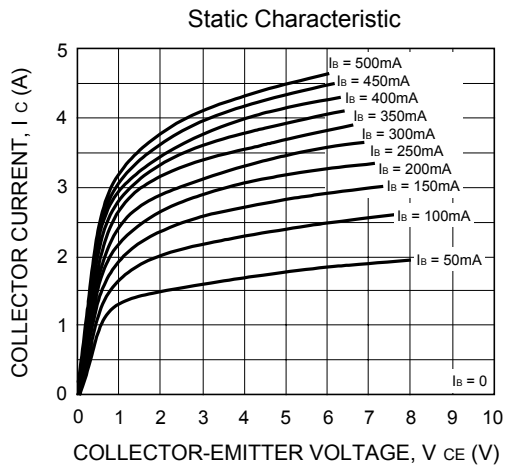

DC current Gain

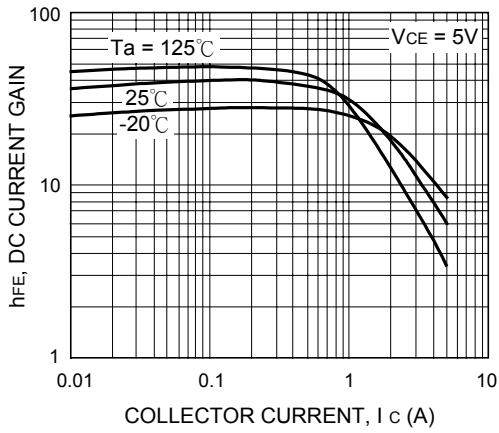

Collector-Emitter Saturation Voltage
Base-Emitter Saturation Voltage

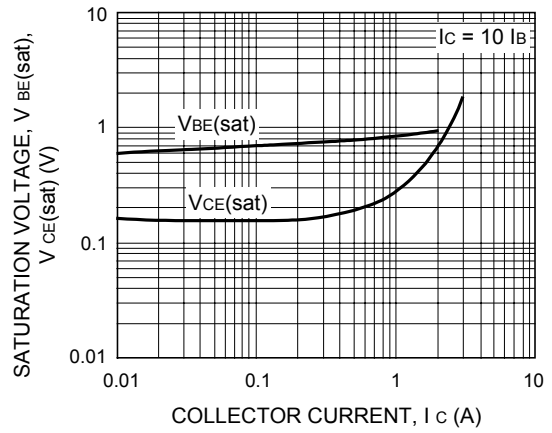

Collector-Emitter Saturation Voltage

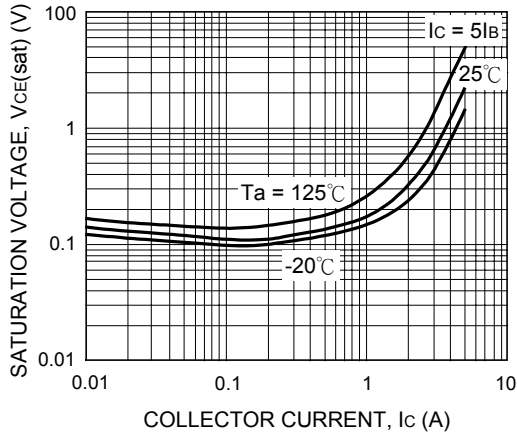

Base-Emitter Saturation Voltage

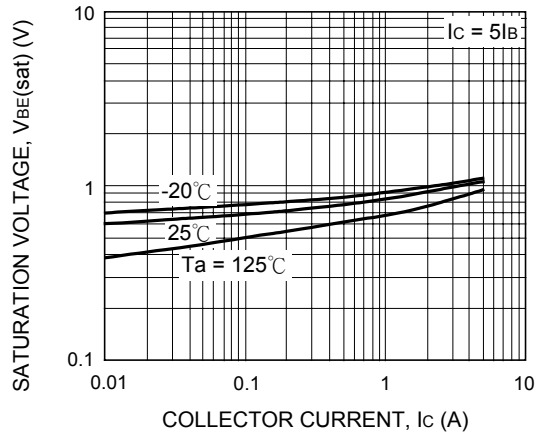

Switching Time

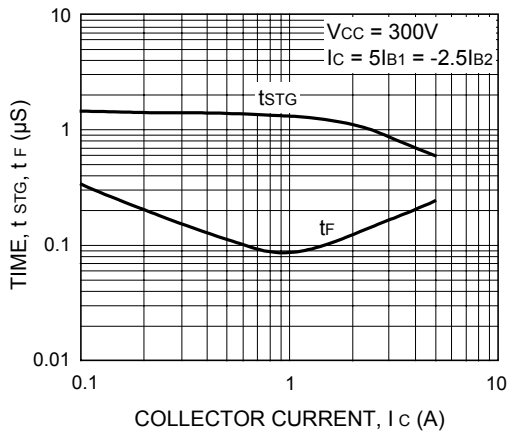

Collector Output Capacitance

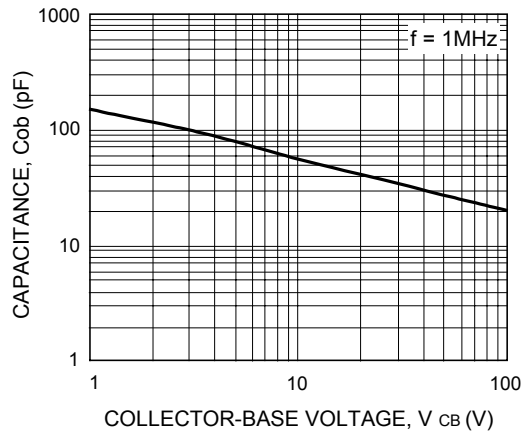

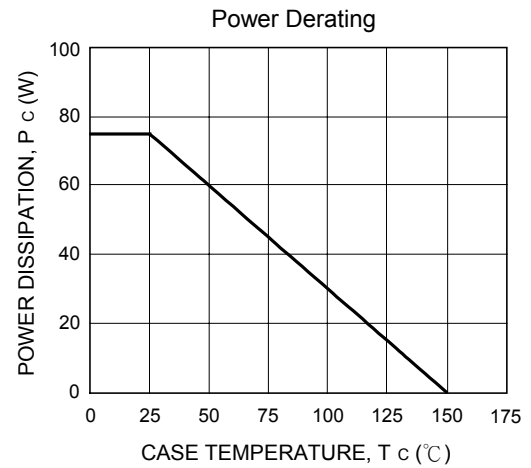
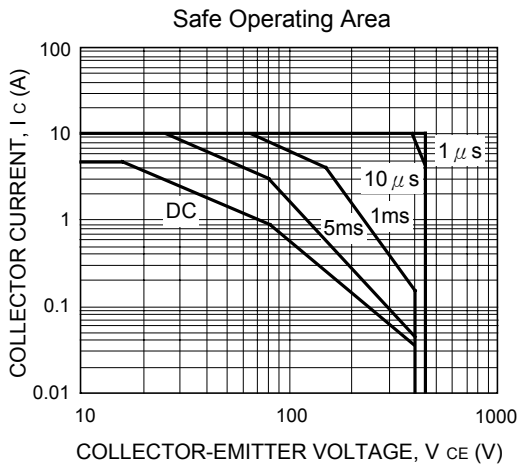
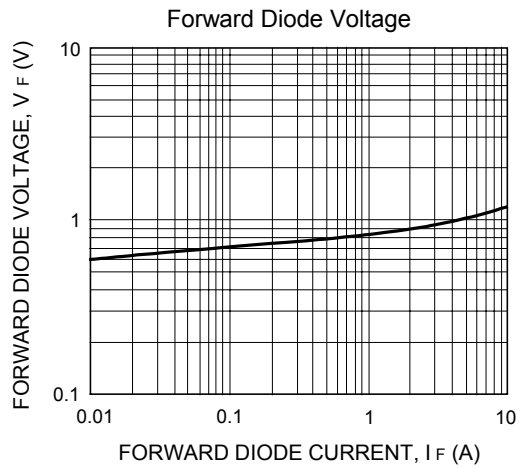
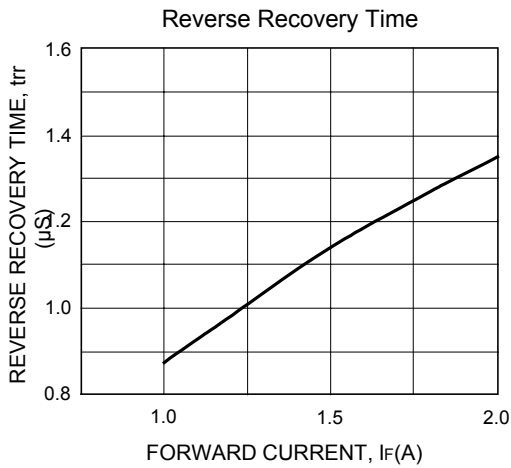

UTC assumes no responsibility for equipment failures that result from using products at values that exceed, even momentarily, rated values (such as maximum ratings, operating condition ranges, or other parameters) listed in products specifications of any and all UTC products described or contained herein. UTC products are not designed for use in life support appliances, devices or systems where malfunction of these products can be reasonably expected to result in personal injury. Reproduction in whole or in part is prohibited without the prior written consent of the copyright owner. The information presented in this document does not form part of any quotation or contract, is believed to be accurate and reliable and may be changed without notice.