



Obsolescence Notice

This product is obsolete.

This information is available for your convenience only.

For more information on Zarlink's obsolete products and replacement product lists, please visit http://products.zarlink.com/obsolete_products/

The SP5524 is a single-chip frequency synthesiser designed for TV tuning systems. Control data is entered in the standard I²C BUS format. The device has six controllable open-collector output ports (P0-P3, P6 and P7), each capable of sinking 10mA. In addition, P1 is a 3-bit 5-level ADC input. The information on these ports can be read via the I²C BUS.

The device has one fixed I²C BUS address and three programmable addresses, allowing two or more synthesisers to be used in a system.

FEATURES

- Complete 1.3GHz Single Chip System
- Programmable via the I²C BUS
- Low Power Consumption (215mW Typ.)
- Low Radiation
- Phase Lock Detector
- Varactor Drive Amp Disable
- 6 Controllable Outputs, 4 Bi-directional
- 5-Level ADC
- Variable I²C BUS Address for Picture in Picture TV
- ESD Protection *

* Normal ESD handling precautions should be observed.

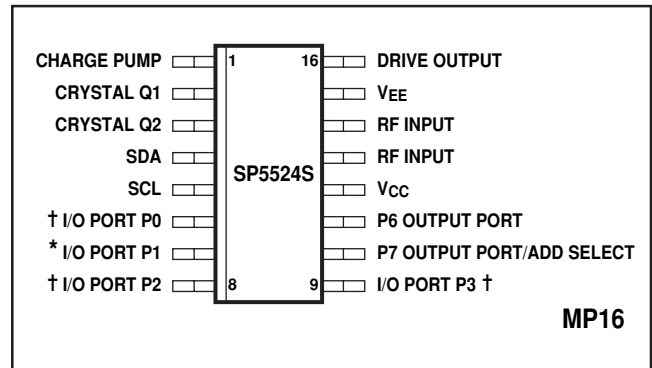

Fig. 1 Pin connections – top view

APPLICATIONS

- Satellite TV when Combined with SP4902 2.5GHz Prescaler
- Cable Tuning Systems
- VCRs

ORDERING INFORMATION

SP5524S KG MPAS (Tubes)
SP5524S KG MPAD (Tape and Reel)

ELECTRICAL CHARACTERISTICS

$T_{AMB} = -10^{\circ}\text{C}$ to $+80^{\circ}\text{C}$, $V_{CC} = +4.5\text{V}$ to $+5.5\text{V}$.

These Characteristics are guaranteed by either production test or design. They apply within the specified ambient temperature and supply voltage ranges unless otherwise stated. Reference frequency 4MHz unless otherwise stated.

Characteristic	Pin	Value			Units	Conditions
		Min.	Typ.	Max.		
Supply current	12		43	53	mA	$V_{CC} = 5\text{V}$
Prescaler input voltage	13,14	12.5 30		300 300	mVrms mVrms	100MHz to 1GHz 50MHz and 1.3GHz, see Fig. 5
Prescaler input impedance	13,14		50		Ω	
Prescaler input capacitance			2		pF	
SDA, SCL						
Input high voltage	4,5	3		5.5	V	Input voltage = V_{CC} Input voltage = 0V When $V_{CC} = 0\text{V}$
Input low voltage	4,5	0		1.5	V	
Input high current	4,5			10	μA	
Input low current	4,5			-10	μA	
Leakage current	4,5			10	μA	
SDA						
Output voltage	4			0.4	V	Sink current = 3mA
Charge pump current low	1		± 50		μA	Byte 4, bit 2 = 0, pin 1 = 2V
Charge pump current high	1		± 170		μA	Byte 4, bit 2 = 1, pin 1 = 2V
Charge pump output leakage current	1			± 5	nA	Byte 4, bit 4 = 1, pin 1 = 2V
Charge pump drive output current	16	500			μA	V pin 16 = 0.7V
Charge pump amplifier gain			6400			
Recommended crystal series resistance		10		200	Ω	Parallel resonant crystal (note 2)
Crystal oscillator drive level			40		mV p-p	
Crystal oscillator negative resistance	2	750			Ω	
Output Ports						
P0-P3, P6, P7 sink current (see note 1)	6-11	10			mA	$V_{OUT} = 0.7\text{V}$, see note 1
P0-P3, P6, P7 leakage current (see note 1)	6-11			10	μA	$V_{OUT} = 13.2\text{V}$
Input Ports						
P7 input current high	10			+10	μA	V pin 10 = 13.2V
P7 input current low	10			-10	μA	V pin 10 = 0V
P0, P2, P3 input voltage low	6,8,9			0.8	V	See Table 3 for ADC levels
P0, P2, P3 input voltage high	6,8,9	2.7			V	
P1 input current high	7			+10	μA	
P1 input current low	7			-10	μA	

NOTES

1. Source impedance between all output ports and ground is approximately 5 Ω . This should be taken into account when calculating output port saturation voltages.
2. The recommended crystal series resistance quoted refers to all conditions including start-up.

ABSOLUTE MAXIMUM RATINGS

All voltages are referred to V_{EE} and pin 3 at 0V.

Parameter	Pin	Value		Units	Conditions
		Min.	Max.		
Supply voltage	12	-0.3	6	V	
RF input voltage	13,14		2.5	V p-p	
Port voltage	6-11	-0.3	14	V	Port in off state
	6-11	-0.3	6	V	Port in on state
Total port output current	6-11		50	mA	
RF input DC offset	13-14	-0.3	$V_{CC}+0.3$	V	
Charge pump DC offset	1	-0.3	$V_{CC}+0.3$	V	
Drive output DC offset	16	-0.3	$V_{CC}+0.3$	V	
Crystal oscillator DC offset	2	-0.3	$V_{CC}+0.3$	V	
SDA, SCL input voltage	4,5	-0.3	$V_{CC}+0.3$	V	With V_{CC} applied
		-0.3	5.5	V	V_{CC} not applied
Storage temperature		-55	+150	°C	
Junction temperature			+150	°C	
MP16 thermal resistance, chip-to-ambient			111	°C/W	
MP16 thermal resistance, chip-to-case			41	°C/W	
Power consumption at 5.5V			321	mW	

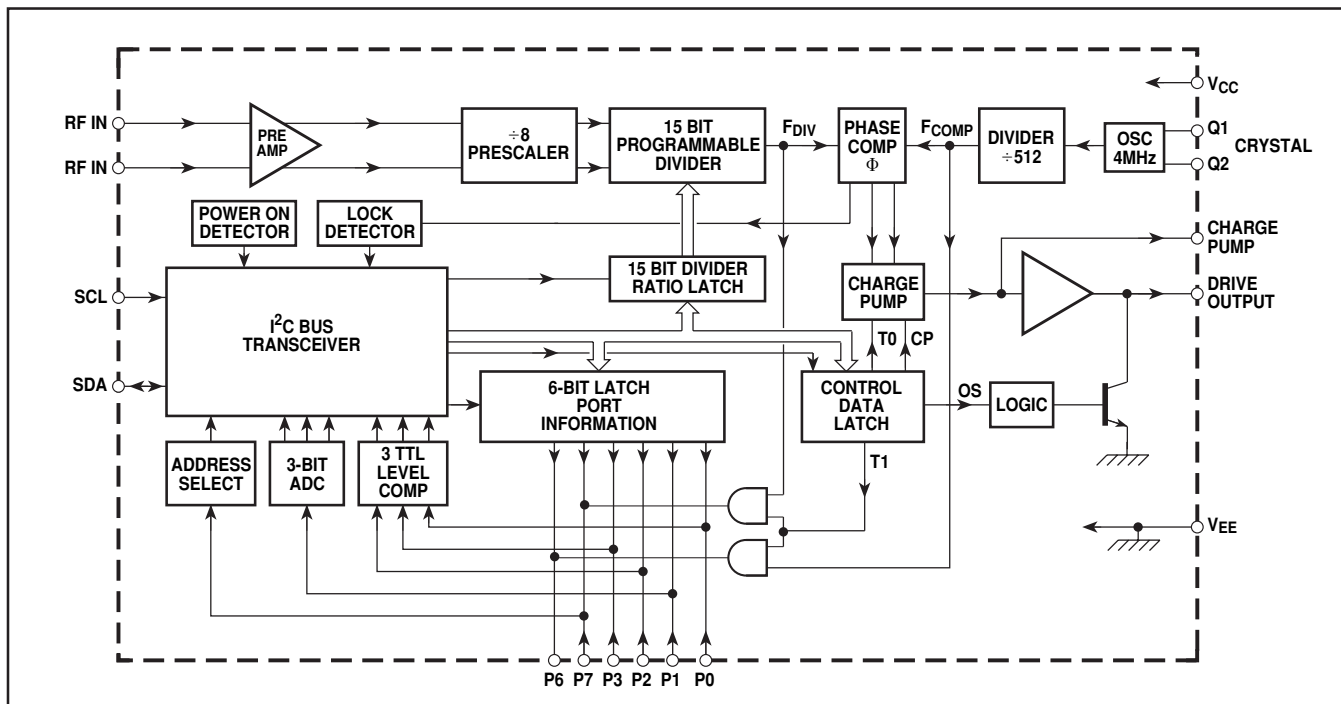

Fig. 2 Block diagram

FUNCTIONAL DESCRIPTION

The SP5524 is programmed from an I²C BUS. Data and Clock are fed in on the SDA and SCL lines respectively as defined by the I²C Bus format. The synthesiser can either accept new data (write mode) or send data (read mode). The Tables in Fig. 3 illustrate the format of the data. The device can be programmed to respond to several addresses, which enables the use of more than one synthesiser in an I²C BUS system. Table 4 shows how the address is selected by applying a voltage to P7. The LSB of the address byte ($\overline{R/W}$) sets the device into read mode if it is high and write mode if it is low. When the SP5524 receives a correct address byte it pulls the SDA line low during the acknowledge period and during following acknowledge periods after further data bytes are programmed. When the SP5524 is programmed into the read mode the controlling device accepting the data must pull down the SDA line during the following acknowledge period to read another status byte.

WRITE MODE (FREQUENCY SYNTHESIS)

When the device is in the write mode Bytes 2+3 select the synthesised frequency while Bytes 4+5 select the output port states and charge pump information.

Once the correct address is received and acknowledged, the first bit of the next byte determines whether that byte is interpreted as Byte 2 or 4, a logic 0 for frequency information and a logic 1 for charge pump and output port information. Additional data bytes can be entered without the need to re-address the device until an I²C stop condition is recognised. This allows a smooth frequency sweep for fine tuning or AFC purposes.

If the transmission of data is stopped mid-byte (e.g., by another device on the bus) then the previously programmed byte is maintained.

Frequency data from Bytes 2 and 3 is stored in a 15-bit shift register and is used to control the division ratio of the 15-bit programmable divider which is preceded by a divide-by-8 prescaler and amplifier to give excellent sensitivity at the local oscillator input; see Fig 5. The input impedance is shown in Fig. 7.

The programmed frequency can be calculated by multiplying the programmed division ratio by 8 times the comparison frequency F_{COMP} .

When frequency data is entered, the phase comparator, via the charge pump and varactor drive amplifier, adjusts the

local oscillator control voltage until the output of the programmable divider is frequency and phase locked to the comparison frequency.

The reference frequency may be generated by an external source capacitively coupled into pin 2 or provided by an on-chip 4MHz crystal controlled oscillator.

Note that the comparison frequency is 7.8125kHz when a 4MHz reference is used.

Bit 2 of Byte 4 of the programming data (CP) controls the current in the charge pump circuit, a logic 1 for $\pm 170\mu\text{A}$ and a logic 0 for $\pm 50\mu\text{A}$, allowing compensation for the variable tuning slope of the tuner and also to enable fast channel changes over the full band. Bit 4 of Byte 4 (T0) disables the charge pump if set to a logic 1. Bit 8 of Byte 4 (OS) switches the charge pump drive amplifier's output off when it is set to a logic 1. Bit 3 of Byte 4 (T1) selects a test mode where the phase comparator inputs are available on P6 and P7, a logic 1 connects F_{COMP} to P6 and F_{DIV} to P7.

Byte 5 programs the output ports P0-P3, P6 and P7, a logic 0 for a high impedance output, logic 1 for low impedance (on).

READ MODE

When the device is in the read mode the status data read from the device on the SDA line takes the form shown in Table 2.

Bit 1 (POR) is the power on reset indicator and is set to a logic 1 if the power supply to the device has dropped below a nominal 3V and the programmed information lost (e.g., when the device is initially turned on). The POR is set to 0 when the read sequence is terminated by a stop command. The outputs are all set to high impedance when the device is initially powered up. Bit 2 (FL) indicates whether the device is phase locked, a logic 1 is present if the device is locked and a logic 0 if the device is unlocked.

Bits 3, 4 and 5 (I2, I1, I0) show the status of the I/O Ports P0, P2 and P3 respectively. A logic 0 indicates a low level and a logic 1 a high level. If the ports are to be used as inputs they should be programmed to a high impedance state (logic1). These inputs will then respond to data complying with standard TTL voltage levels. Bits 6, 7 and 8 (A2,A1,A0) combine to give the output of the 5-level ADC.

The 5-level ADC can be used to feed AFC information to the microprocessor from the IF section of the television, as illustrated in Fig. 4.

	MSB					LSB				
Address	1	1	0	0	0	MA1	MA0	0	A	Byte 1
Programmable divider	0	2^{14}	2^{13}	2^{12}	2^{11}	2^{10}	2^9	2^8	A	Byte 2
Programmable divider	2^7	2^6	2^5	2^4	2^3	2^2	2^1	2^0	A	Byte 3
Charge pump and test bits	1	CP	T1	T0	1	1	1	OS	A	Byte 4
I/O port control bits	P7	P6	X	X	P3	P2	P1	P0	A	Byte 5

Table 1 Write data format (MSB transmitted first)

Address	1	1	0	0	0	MA1	MA0	1	A	Byte 1
Status byte	POR	FL	I2	I1	I0	A2	A1	A0	A	Byte 2

Table 2 Read data format

A2	A1	A0	Voltage input to P1
1	0	0	0·6V _{CC} to 13·2V
0	1	1	0·45V _{CC} to 0·6V _{CC}
0	1	0	0·3V _{CC} to 0·45V _{CC}
0	0	1	0·15V _{CC} to 0·3V _{CC}
0	0	0	0V to 0·15V _{CC}

Table 3 ADC levels

MA1	MA0	Voltage input to P7
0	0	0V to 0·2V _{CC}
0	1	Always valid
1	0	0·3V _{CC} to 0·7V _{CC}
1	1	0·8V _{CC} to 13·2V

Table 4 Address selection

A	: Acknowledge bit
MA1, MA0	: Variable address bits (see Table 4)
CP	: Charge Pump current select
T1	: Test mode selection
T0	: Charge pump disable
OS	: Varactor drive Output disable Switch
P7, P6	: Control output port states
P3, P2, P1, P0	
POR	: Power On Reset indicator
FL	: Phase lock detect flag
I2, I1, I0	: Digital information from ports P0, P2 and P3 respectively
A2, A1, A0	: 5-level ADC data from P1 (see Table 3)
X	: Don't care

Fig. 3 Data formats

APPLICATION

A typical application is shown in Fig. 4. All input/output interface circuits are shown in Fig. 6.

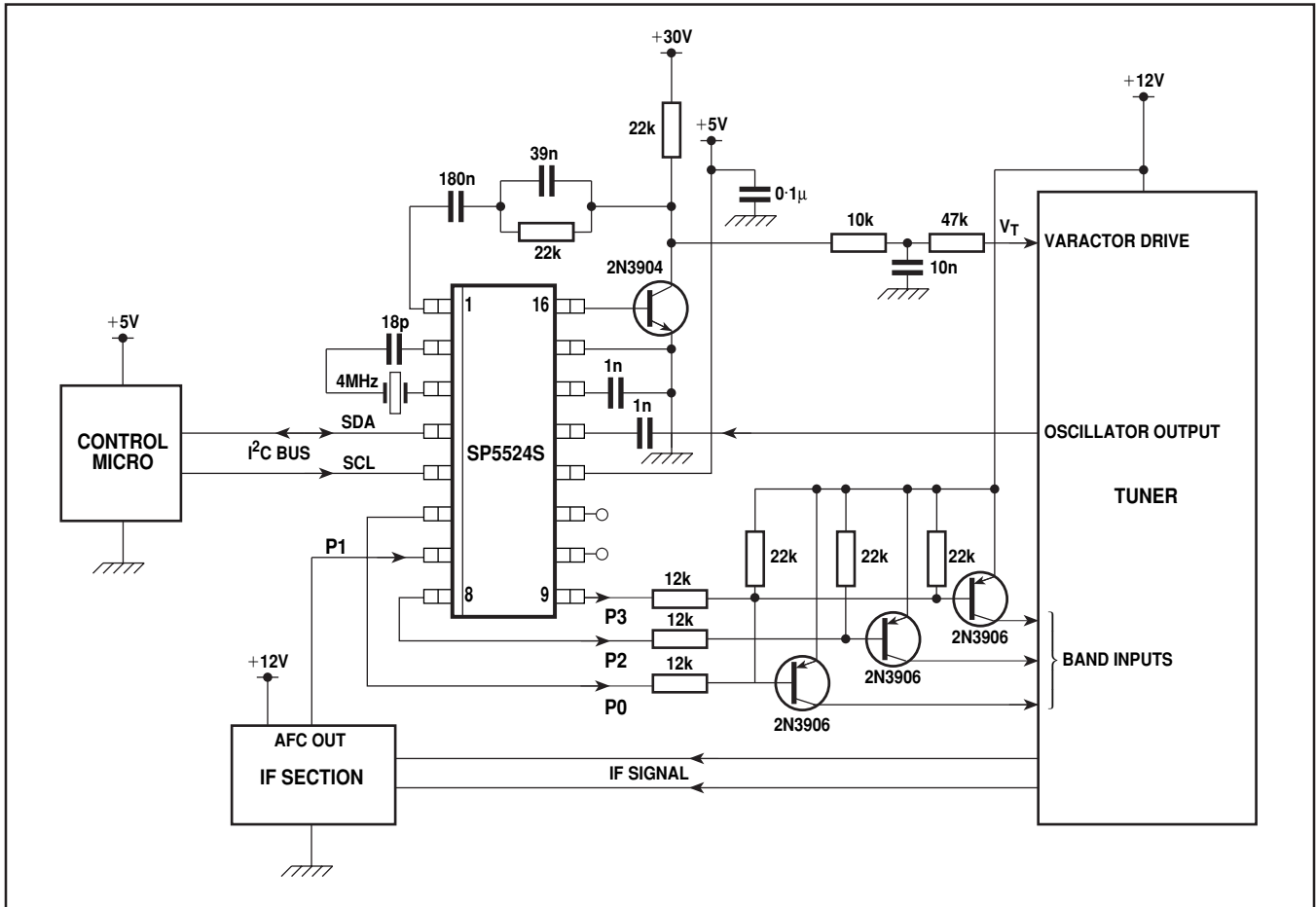

Fig. 4 Typical application

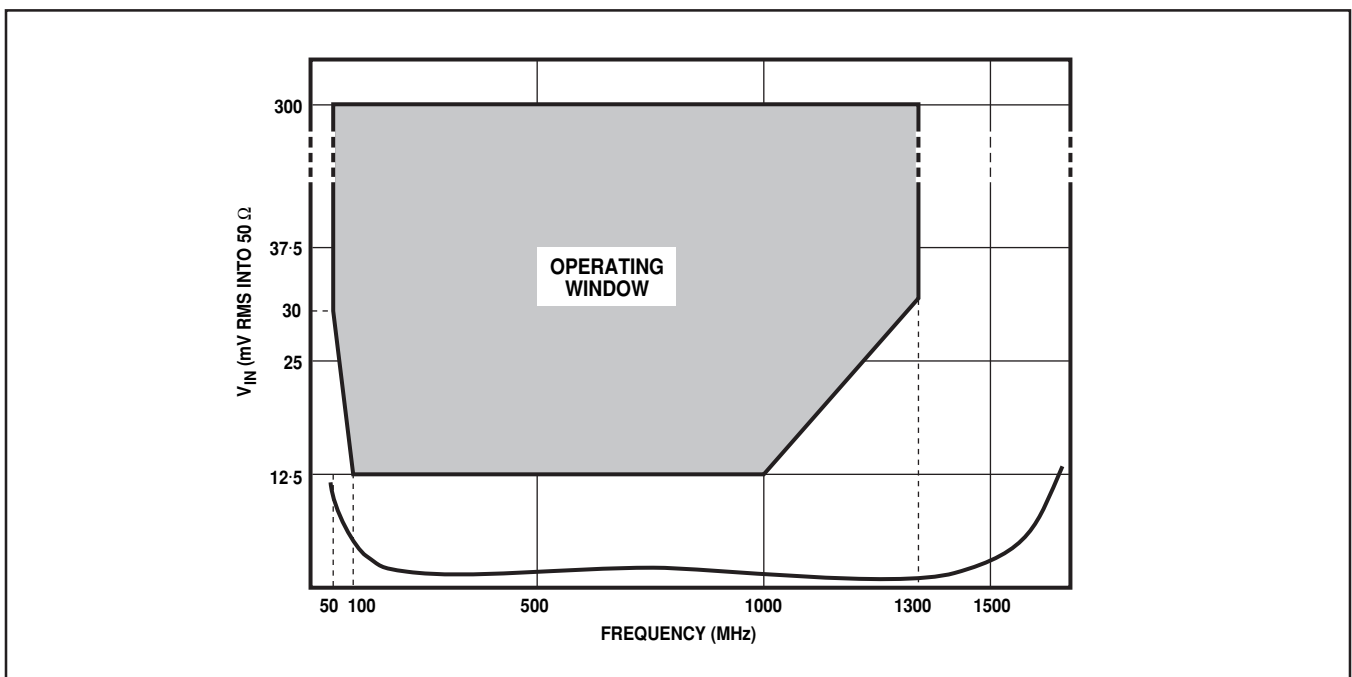
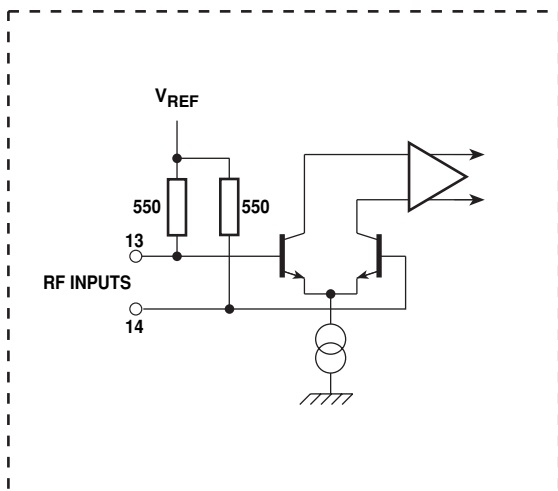
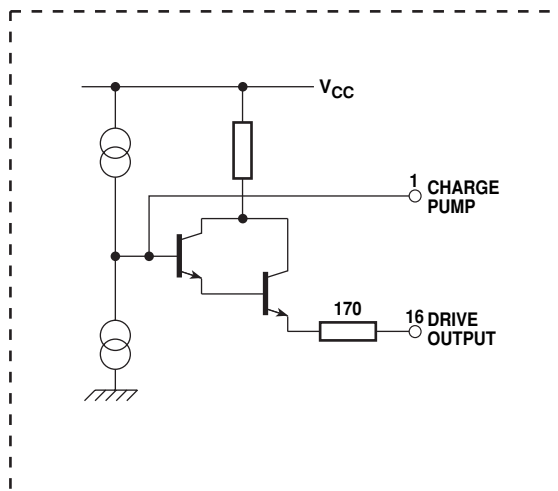

Fig. 5 Typical input sensitivity



RF input



Loop amplifier

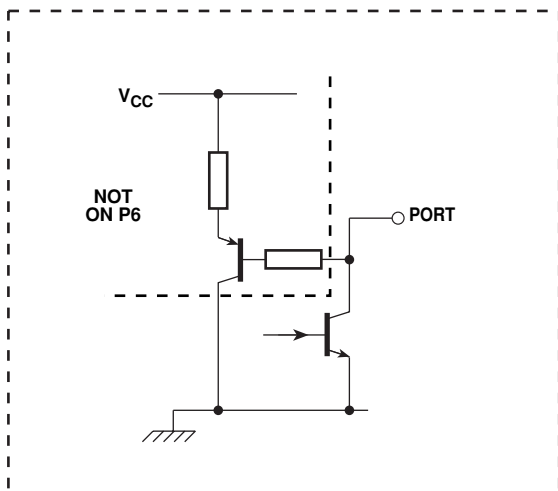

Ports P0 - P3, P6 and P7

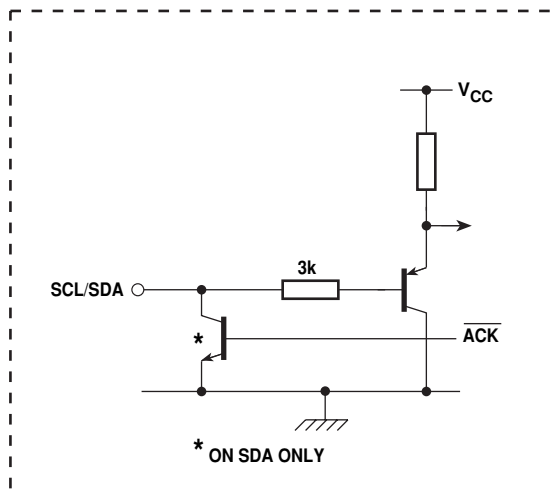

SCL and SDA inputs

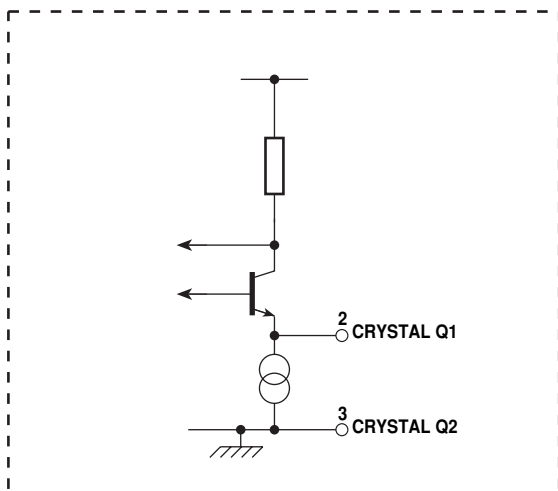

Reference oscillator

Fig. 6 Input/output interface circuits

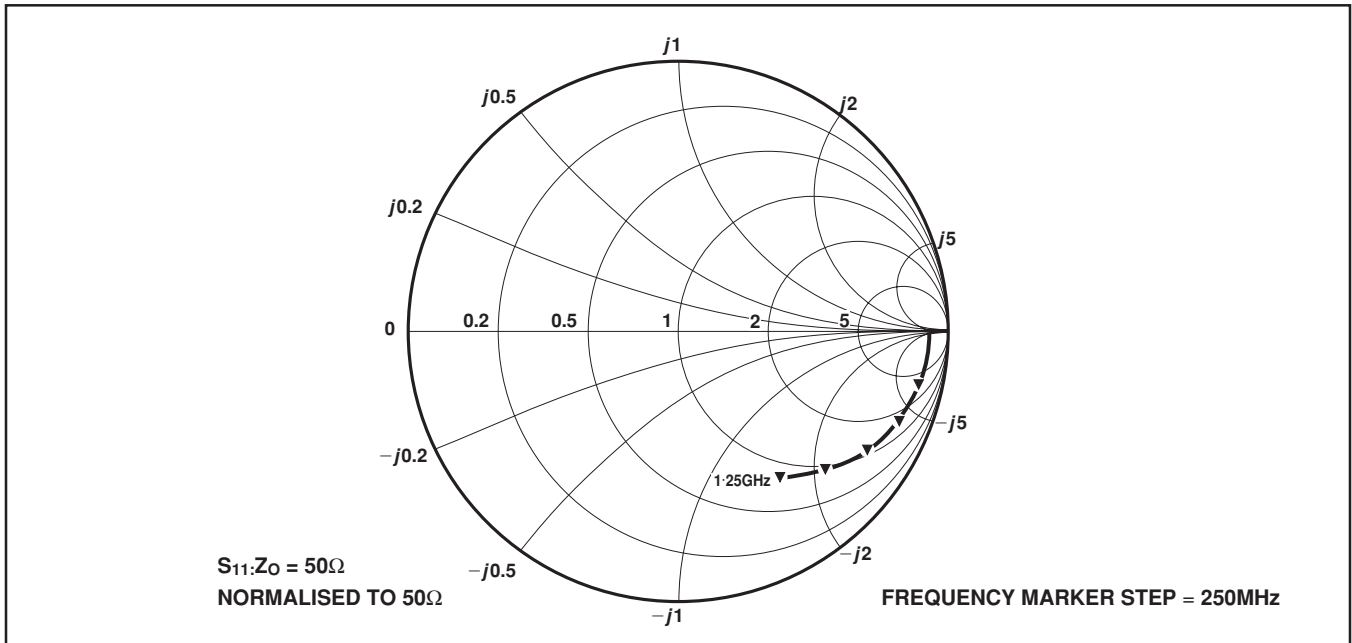

Fig. 7 Typical input impedance



**For more information about all Zarlink products
visit our Web Site at
www.zarlink.com**

Information relating to products and services furnished herein by Zarlink Semiconductor Inc. or its subsidiaries (collectively "Zarlink") is believed to be reliable. However, Zarlink assumes no liability for errors that may appear in this publication, or for liability otherwise arising from the application or use of any such information, product or service or for any infringement of patents or other intellectual property rights owned by third parties which may result from such application or use. Neither the supply of such information or purchase of product or service conveys any license, either express or implied, under patents or other intellectual property rights owned by Zarlink or licensed from third parties by Zarlink, whatsoever. Purchasers of products are also hereby notified that the use of product in certain ways or in combination with Zarlink, or non-Zarlink furnished goods or services may infringe patents or other intellectual property rights owned by Zarlink.

This publication is issued to provide information only and (unless agreed by Zarlink in writing) may not be used, applied or reproduced for any purpose nor form part of any order or contract nor to be regarded as a representation relating to the products or services concerned. The products, their specifications, services and other information appearing in this publication are subject to change by Zarlink without notice. No warranty or guarantee express or implied is made regarding the capability, performance or suitability of any product or service. Information concerning possible methods of use is provided as a guide only and does not constitute any guarantee that such methods of use will be satisfactory in a specific piece of equipment. It is the user's responsibility to fully determine the performance and suitability of any equipment using such information and to ensure that any publication or data used is up to date and has not been superseded. Manufacturing does not necessarily include testing of all functions or parameters. These products are not suitable for use in any medical products whose failure to perform may result in significant injury or death to the user. All products and materials are sold and services provided subject to Zarlink's conditions of sale which are available on request.

Purchase of Zarlink's I²C components conveys a licence under the Philips I²C Patent rights to use these components in and I²C System, provided that the system conforms to the I²C Standard Specification as defined by Philips.

Zarlink, ZL and the Zarlink Semiconductor logo are trademarks of Zarlink Semiconductor Inc.

Copyright Zarlink Semiconductor Inc. All Rights Reserved.

TECHNICAL DOCUMENTATION - NOT FOR RESALE
