

CAN Transceiver

FEATURES

- Pin Compatible with PCA82C250 and DeviceNet, SDS, ISO11898 Compatible
- High Speed, up to 1Mbps
- Differential Transmit to the Bus and Receive from the Bus to the CAN Controller
- At Least 110 Nodes Can Be Connected
- 100V Transient Protection on the Transmit Output
- 24V Supply Cross Wire Protection on CANH and CANL
- No Bus Loading When Powered Down
- Operates over -40°C to $+85^{\circ}\text{C}$
- Unitrode DeviceNet ID#107

DESCRIPTION

The UC5350 Control Area Network Transceiver is designed for industrial applications employing the CAN serial communications physical layer per ISO 11898 standard. The device is a high speed transceiver designed for use up to 1Mbps. Especially designed for hostile environments, this device features cross wire, loss of ground, over voltage, and over temperature protections well as a wide common mode range.

The transceiver interfaces the single ended CAN controller with the differential CAN bus found in industrial and automotive applications. It operates over the -7V to $+12\text{V}$ common mode range of the bus and will withstand common mode transients of -25V to $+18\text{V}$ as well as Schaffner tests. Performance features include high differential input impedance, a symmetrical differential signal driver and very low propagation delay that improves bus bandwidth and length by reducing reflection and distortion.

The transceiver operates over a wide temperature range, -40°C to $+85^{\circ}\text{C}$ and is available in 8-pin SOIC and Dual-in-Line packages.

FUNCTIONAL TABLE (VCC = 4.5V to 5.5V)

Inputs		System Mode	Output Mode	Outputs	
TXD	RS			VCANH - VCANL	RXD
0	0	High Speed	Dominant	1.5V to 3V	0
1	0	High Speed	Recessive	-120mV to $+12\text{mV}$	1
High Z	0	High Speed	Recessive	-120mV to $+12\text{mV}$	1
X	1	Standby		High Z	0 at Bus = Dominant 1 at Bus = Recessive

BLOCK DIAGRAM

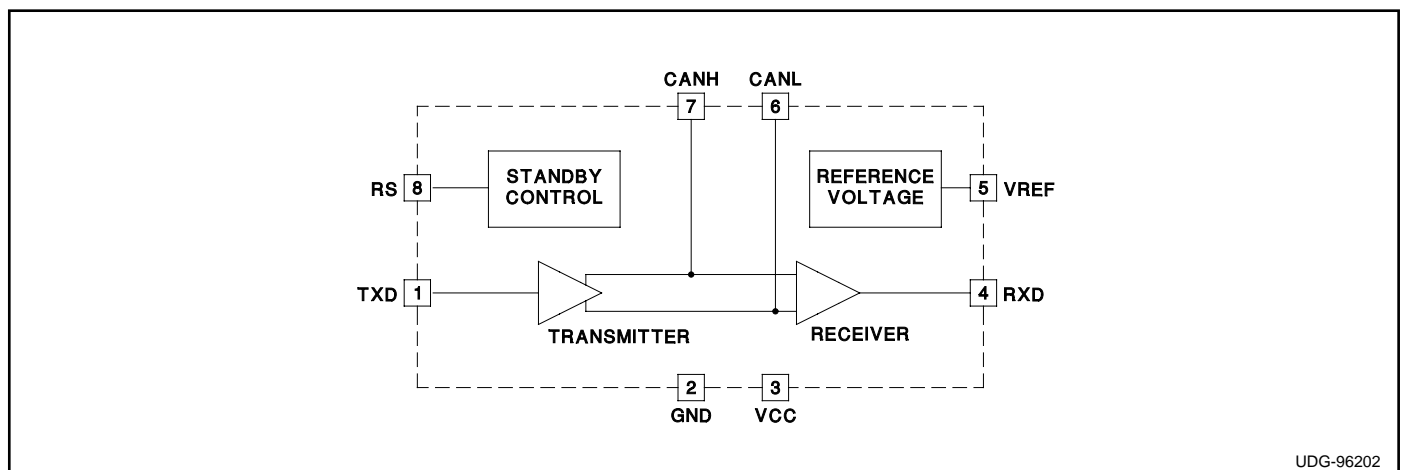

UDG-96202

ABSOLUTE MAXIMUM RATINGS

Supply Voltage	−0.3V to 9V
TXD, RXD, VREF, RS	−0.3V to VCC + 0.3V
CANL, CANH	
0V < VCC < 5.5V	−8V to +36V
Non-Destructive, Non-Operative	−8V to +32V
Transient, Schaffner Test (Fig. 1)	−150 to +100V
Operating Temperature	−40°C to +85°C
Storage Temperature	−65°C to +150°C
Junction Temperature	−55°C to +150°C
Lead Temperature (Soldering, 10 sec.)	+300°C
Crosswire Protection Maximum VBUS	30V
Bus Differential Voltage*	30V
Cross Wire Protection TA	−40°C to 125°C

Currents are positive into, negative out of the specified terminal.

Consult Packaging Section of the Databook for thermal limitations and considerations of packages.

*Refers to Figures 9, 10, 11, 12 and 13.

CONNECTION DIAGRAM**DIL-8, SOIC-8 (Top View)
N, D Package**

Figure 1. Schaffner Test

ELECTRICAL CHARACTERISTICS (Total Device) Unless otherwise stated, the device is disconnected from the bus line; VCC = 4.5V to 5.5V; 60_ in parallel with 100pF load between CANH and CANL; TA = −40°C to +85°C, TA = TJ

PARAMETER	TEST CONDITIONS	MIN	TYP	MAX	UNITS
Supply Voltage		4.5		5.5	V
Supply Current	Dominant, TXD = 1V			70	mA
	Recessive, TXD = 4V		9	14	mA
	Standby, RS = 4V		1.2	2.0	mA
RS Input Current		−10		5	μA
RS Voltage Input = Logic 1	Standby	0.75VCC			V
RS Voltage Input = Logic 0	High Speed			0.3VCC	V
Transmitter Voltage Input = Logic 1	Transmitter Output Recessive	0.7VCC			V
Transmitter Voltage Input = Logic 0	Transmitter Output Dominant			0.3VCC	V
Transmitter Current Input at Logic 1	TXD = 4V			30	μA
Transmitter Current Input at Logic 0	TXD = 1V	−30		30	μA
Receiver Voltage Output = Logic 1	RXD = −100μA, TXD = 4V	VCC − 1.25			V
Receiver Voltage Output = Logic 0	RXD = 1mA, TXD = 1V		0.75	1.2	V
	RXD = 10mA, TXD = 1V		1.2	1.7	V
CANH, CANL Input Resistance	No Load, TXD = 4V	20	40		kΩ
Differential Input Resistance	No Load, TXD = 4V	40	80		kΩ
CANH, CANL Input Capacitance	(Note 1)			20	pF
Differential Input Capacitance	(Note 1)			10	pF
Reference Output Voltage	VREF = ±50μA	0.45VCC		0.55VCC	V

Note 1: Guaranteed by design. Not 100% tested in production.

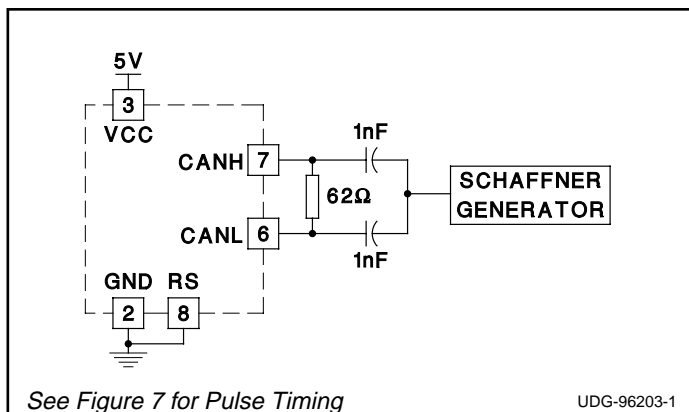
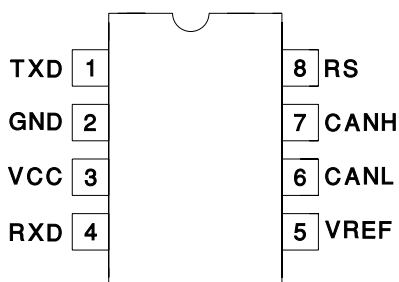
ELECTRICAL CHARACTERISTICS (DC Parameters For Recessive State) Unless otherwise stated, the device is disconnected from the bus line; 60Ω in parallel with 100pF load between CANH and CANL.

PARAMETER	TEST CONDITIONS	MIN	TYP	MAX	UNITS
V _{CANH} , V _{CANL}	No Load, TXD = 4V (Figure 2)	2	2.5	3	V
Differential Output Transmitter (V _{CANH} - V _{CANL})	No Load, TXD = 4V (Figure 2)	-500	0	50	mV
Differential Input Receiver	Common Mode Range = -7V to +12V, TXD = 4V, CANH, CANL Externally Driven (Figure 3)	-1		0.40	V
Differential Input Resistance	No Load	40			kΩ
CANH, CANL Input Resistance		20			kΩ

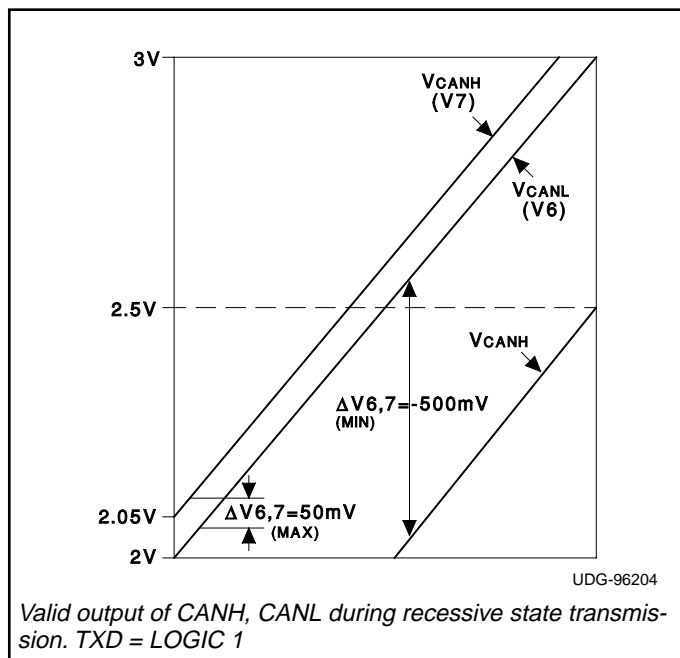

Figure 2. Recessive State Voltage Diagram

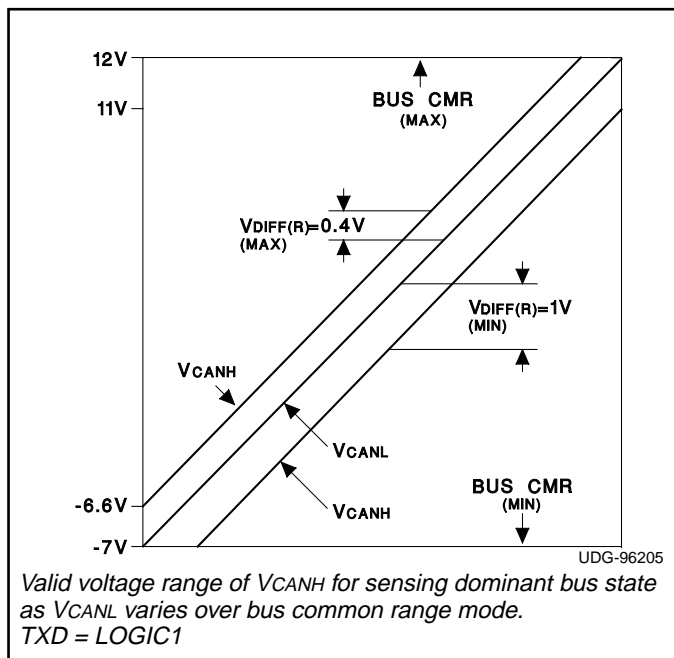

Figure 3. Recessive State Voltage Diagram

ELECTRICAL CHARACTERISTICS (DC Parameters For Dominant State) Unless otherwise stated, the device is disconnected from the bus line; 60 Ω in parallel with 100pF load between CANH and CANL. VCC = 4.5V to 5.5V

PARAMETER	TEST CONDITIONS	MIN	TYP	MAX	UNITS
CANH Output Voltage (V _{CANH})	TXD = 1V (Figure 4)	2.75		4.5	V
CANL Output Voltage (V _{CANL})	TXD = 1V (Figure 4)	0.50	1.1	2.25	V
Differential Output Transmitter (V _{CANH} - V _{CANL})	TXD = 1V (Figure 4)	1.5	2	3	V
Differential Input Receiver (V _{DIFF(D)})	Common Mode Range = -2 to +7V, TXD = 4V, CANH, CANL Externally Driven (Figure 5)	0.9		5	V
	Common Mode Range = -7 to +12V, TXD = 4V, CANH, CANL Externally Driven (Figure 5)	1.0		5	V

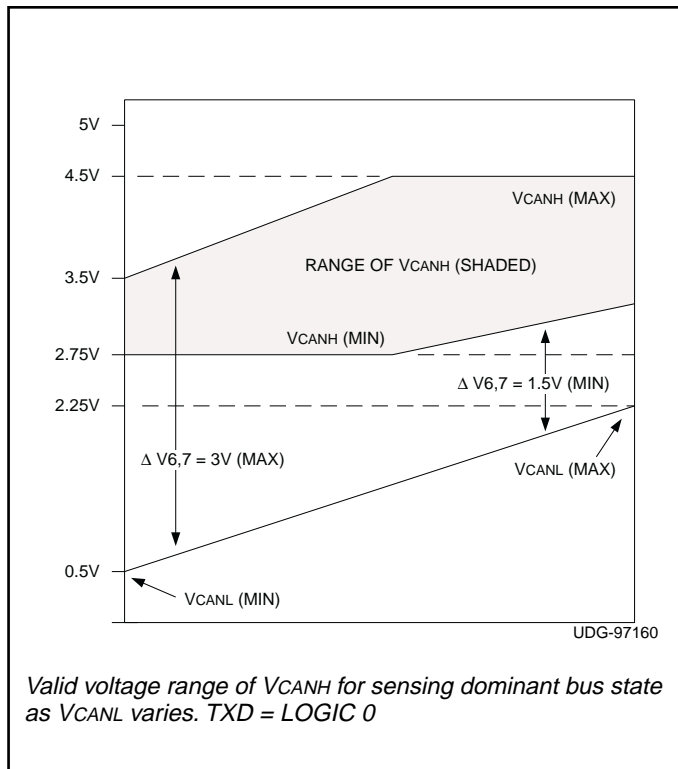

Figure 4. Dominant State Voltage Diagram

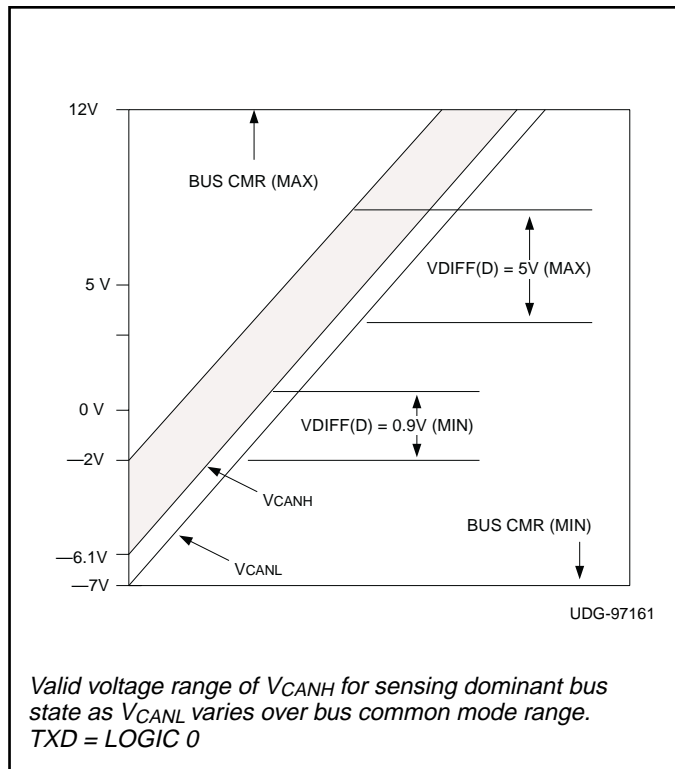

Figure 5. Dominant State Voltage Diagram

TRANSMITTER CHARACTERISTICS

Unless otherwise stated, the device is disconnected from the bus line; 60 Ω in parallel with 100pF load between CANH and CANL.

PARAMETER	TEST CONDITIONS	MIN	TYP	MAX	UNITS
Differential Output Transmitter (V _{CANH} - V _{CANL})	Dominant Mode	1.5	2	3	V
	Recessive Mode	-500		50	mV
Delay From TXD to Bus Active T _{ON} (TXD)	(Figure 6)		50	100	ns
Delay From TXD to Bus Inactive T _{OFF} (TXD)	60 Ω Across CANH and CANL (Figure 6)		20	110	ns

RECEIVER CHARACTERISTICS

Unless otherwise stated, the device is disconnected from the bus line; 60Ω in parallel with 100pF load between CANH and CANL.

PARAMETER	TEST CONDITIONS	MIN	TYP	MAX	UNITS
Differential Input Receiver (V _{CANH} - V _{CANL})	Dominant Mode, TXD = 4V	0.9			V
	Recessive Mode, TXD = 4V			0.4	V
Differential Input Hysteresis	TXD = 4V	75	150		mV
Delay From Bus to RXD (T _{ON})	Inactive to Active Bus (Figure 6)		60	100	ns
Delay From Bus to RXD (T _{OFF})	Active to Inactive Bus, 60Ω Across CANH and CANL (Figure 6)		80	115	ns

TRANSCEIVER CHARACTERISTICS

PARAMETER	TEST CONDITIONS	MIN	TYP	MAX	UNITS
Loop Time	T _{ON} (TXD) + T _{ON} (RXD) Inactive to active bus		110	200	ns
	T _{OFF} (TXD) + T _{OFF} (RXD) Active to inactive bus		100	225	ns

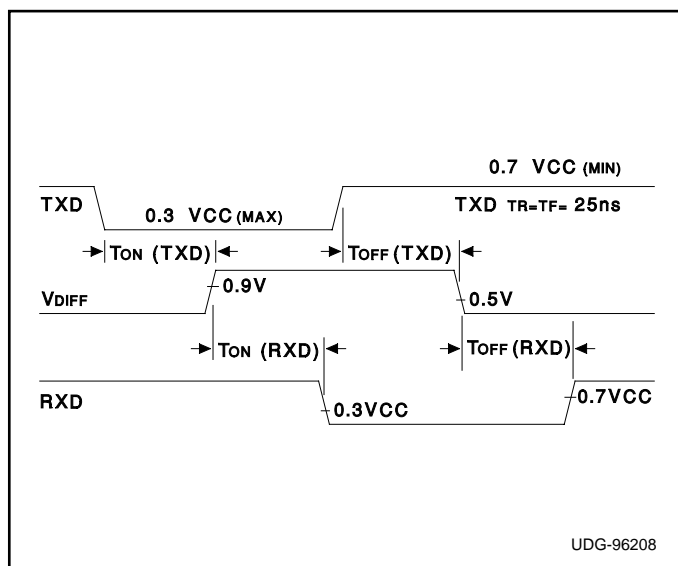

Figure 6. Transceiver AC Response

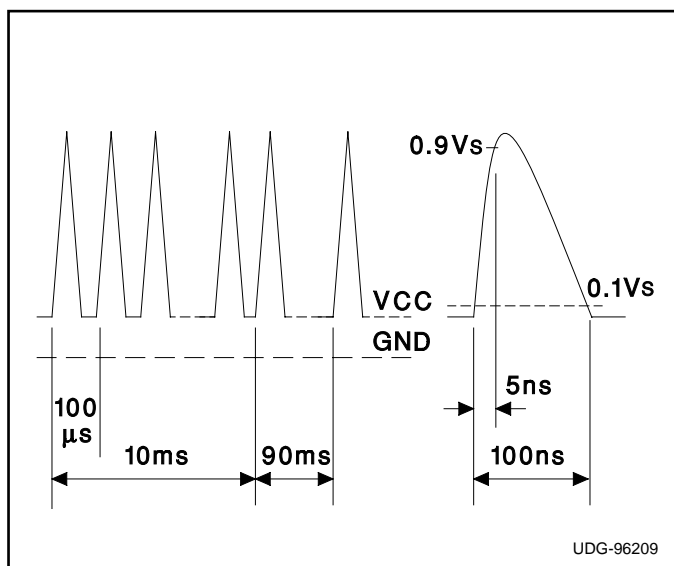

Figure 7. Timing Diagram for Schaffner Tests

Magnitude Specifications for Vs

ISO	DIN 40839-1	Schaffner
DP7637/1	(Draft)	NSG500C/506C
Up to 150V	Up to 150V	40V to 200V

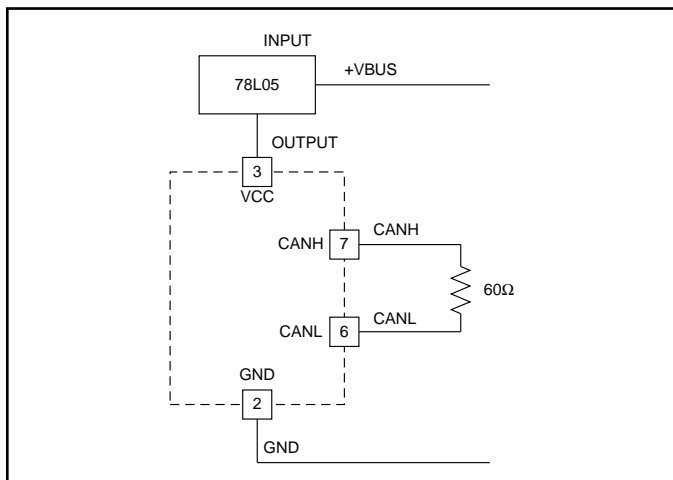

Figure 8. Normal Connection

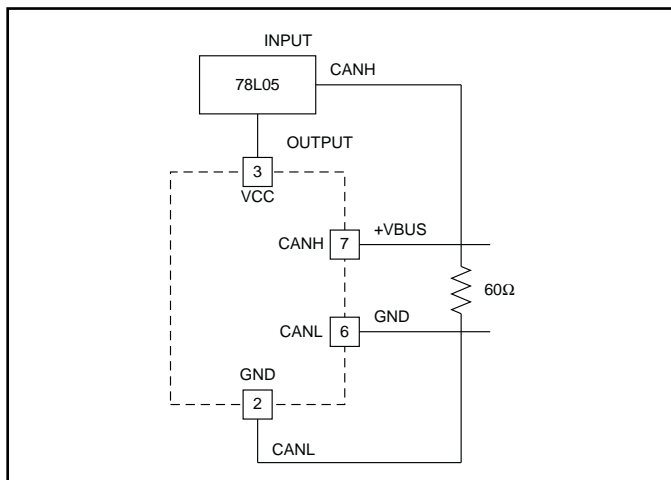

Figure 9. Crosswire No. 1

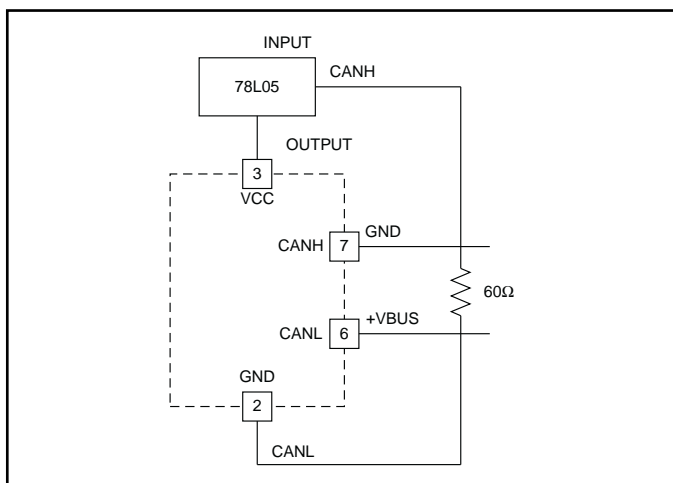

Figure 10. Crosswire No. 2

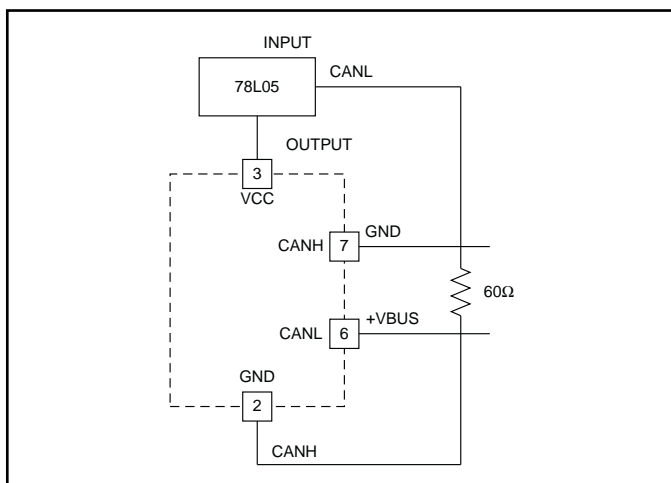

Figure 11. Crosswire No. 3

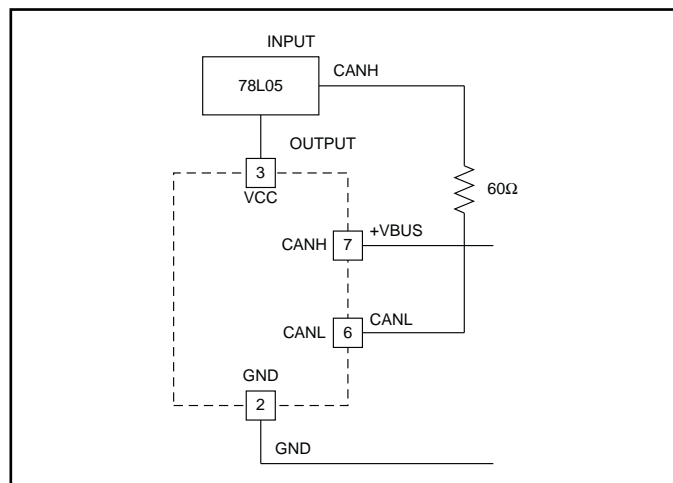

Figure 12. Crosswire No. 4

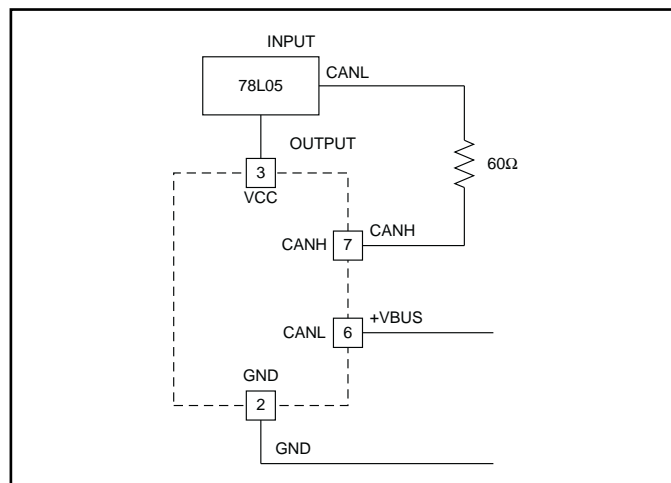

Figure 13. Crosswire No. 5

IMPORTANT NOTICE

Texas Instruments and its subsidiaries (TI) reserve the right to make changes to their products or to discontinue any product or service without notice, and advise customers to obtain the latest version of relevant information to verify, before placing orders, that information being relied on is current and complete. All products are sold subject to the terms and conditions of sale supplied at the time of order acknowledgment, including those pertaining to warranty, patent infringement, and limitation of liability.

TI warrants performance of its semiconductor products to the specifications applicable at the time of sale in accordance with TI's standard warranty. Testing and other quality control techniques are utilized to the extent TI deems necessary to support this warranty. Specific testing of all parameters of each device is not necessarily performed, except those mandated by government requirements.

Customers are responsible for their applications using TI components.

In order to minimize risks associated with the customer's applications, adequate design and operating safeguards must be provided by the customer to minimize inherent or procedural hazards.

TI assumes no liability for applications assistance or customer product design. TI does not warrant or represent that any license, either express or implied, is granted under any patent right, copyright, mask work right, or other intellectual property right of TI covering or relating to any combination, machine, or process in which such semiconductor products or services might be or are used. TI's publication of information regarding any third party's products or services does not constitute TI's approval, warranty or endorsement thereof.