

Product Description

Peregrine's PE9702 is a high-performance integer-N PLL capable of frequency synthesis up to 3000 MHz. The device is designed for superior phase noise performance while providing an order of magnitude reduction in current consumption, when compared with existing commercial space PLLs.

The PE9702 features a 10/11 dual modulus prescaler, counters and a phase comparator as shown in Figure 1. Counter values are programmable through either a serial or parallel interface and can also be directly hard wired.

The PE9702 is optimized for commercial space applications. Single Event Latch up (SEL) is physically impossible and Single Event Upset (SEU) is better than 10^{-9} errors per bit / day. It is manufactured on Peregrine's UltraCMOS™ process, a patented variation of silicon-on-insulator (SOI) technology on a sapphire substrate, offering excellent RF performance and intrinsic radiation tolerance.

Features

- 3000 MHz operation
- $\div 10/11$ dual modulus prescaler
- Internal phase detector
- Serial, parallel or hardwired programmable
- Ultra-low phase noise
- SEU < 10^{-9} errors / bit-day
- 100 Krad (Si) total dose
- 44-lead CQFJ

Figure 1. Block Diagram

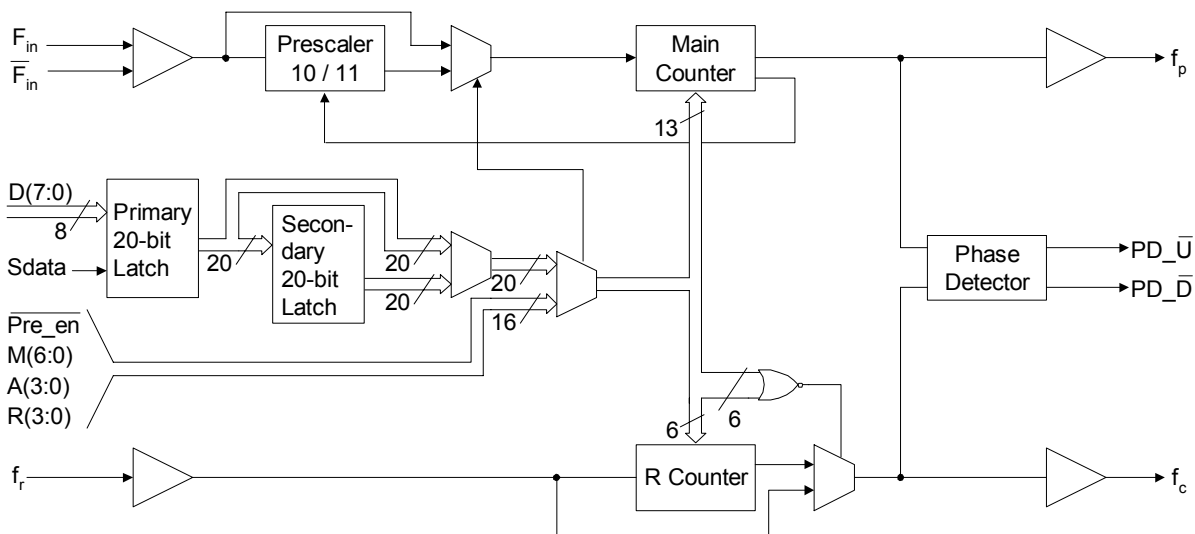

Figure 2. Pin Configurations (Top View)

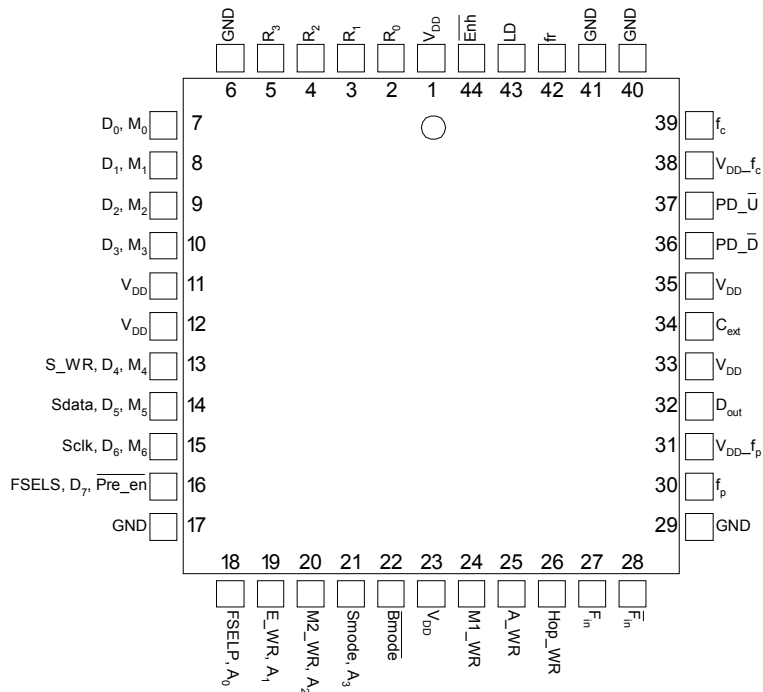

Figure 3. Package Type
44-lead CQFJ

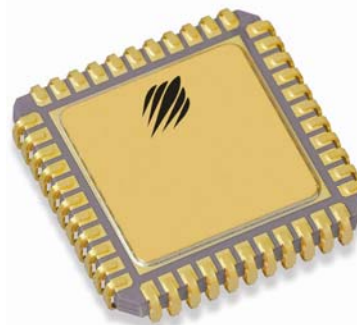

Table 1. Pin Descriptions

Pin No.	Pin Name	Interface Mode	Type	Description
1	V _{DD}	ALL	(Note 1)	Power supply input. Input may range from 2.85 V to 3.15 V. Bypassing recommended.
2	R ₀	Direct	Input	R Counter bit0 (LSB).
3	R ₁	Direct	Input	R Counter bit1.
4	R ₂	Direct	Input	R Counter bit2.
5	R ₃	Direct	Input	R Counter bit3.
6	GND	ALL	(Note 1)	Ground.
7	D ₀	Parallel	Input	Parallel data bus bit0 (LSB).
	M ₀	Direct	Input	M Counter bit0 (LSB).
8	D ₁	Parallel	Input	Parallel data bus bit1.
	M ₁	Direct	Input	M Counter bit1.
9	D ₂	Parallel	Input	Parallel data bus bit2.
	M ₂	Direct	Input	M Counter bit2.
10	D ₃	Parallel	Input	Parallel data bus bit3.
	M ₃	Direct	Input	M Counter bit3.
11	V _{DD}	ALL	(Note 1)	Same as pin 1.
12	V _{DD}	ALL	(Note 1)	Same as pin 1.
13	S_WR	Serial	Input	Serial load enable input. While S_WR is "low", Sdata can be serially clocked. Primary register data is transferred to the secondary register on S_WR or Hop_WR rising edge.
	D ₄	Parallel	Input	Parallel data bus bit4
	M ₄	Direct	Input	M Counter bit4

Table 1. Pin Descriptions (continued)

Pin No.	Pin Name	Interface Mode	Type	Description
14	Sdata	Serial	Input	Binary serial data input. Input data entered MSB first.
	D ₅	Parallel	Input	Parallel data bus bit5.
	M ₅	Direct	Input	M Counter bit5.
15	Sclk	Serial	Input	Serial clock input. Sdata is clocked serially into the 20-bit primary register (E_WR "low") or the 8-bit enhancement register (E_WR "high") on the rising edge of Sclk.
	D ₆	Parallel	Input	Parallel data bus bit6.
	M ₆	Direct	Input	M Counter bit6.
16	FSELS	Serial	Input	Selects contents of primary register (FSELS=1) or secondary register (FSELS=0) for programming of internal counters while in Serial Interface Mode.
	D ₇	Parallel	Input	Parallel data bus bit7 (MSB).
	$\overline{\text{Pre_en}}$	Direct	Input	Prescaler enable, active "low". When "high", F _{in} bypasses the prescaler.
17	GND	ALL		Ground.
18	FSELP	Parallel	Input	Selects contents of primary register (FSELP=1) or secondary register (FSELP=0) for programming of internal counters while in Parallel Interface Mode.
	A ₀	Direct	Input	A Counter bit0 (LSB).
19	E_WR	Serial	Input	Enhancement register write enable. While E_WR is "high", Sdata can be serially clocked into the enhancement register on the rising edge of Sclk.
		Parallel	Input	Enhancement register write. D[7:0] are latched into the enhancement register on the rising edge of E_WR.
	A ₁	Direct	Input	A Counter bit1.
20	M2_WR	Parallel	Input	M2 write. D[3:0] are latched into the primary register (R[5:4], M[8:7]) on the rising edge of M2_WR.
	A ₂	Direct	Input	A Counter bit2.
21	Smode	Serial, Parallel	Input	Selects serial bus interface mode (Bmode=0, Smode=1) or Parallel Interface Mode (Bmode=0, Smode=0).
	A ₃	Direct	Input	A Counter bit3 (MSB).
22	$\overline{\text{Bmode}}$	ALL	Input	Selects direct interface mode ($\overline{\text{Bmode}}$ =1).
23	V _{DD}	ALL	(Note 1)	Same as pin 1.
24	M1_WR	Parallel	Input	M1 write. D[7:0] are latched into the primary register ($\overline{\text{Pre_en}}$, M[6:0]) on the rising edge of M1_WR.
25	A_WR	Parallel	Input	A write. D[7:0] are latched into the primary register (R[3:0], A[3:0]) on the rising edge of A_WR.
26	Hop_WR	Serial, Parallel	Input	Hop write. The contents of the primary register are latched into the secondary register on the rising edge of Hop_WR.
27	F _{in}	ALL	Input	Prescaler input from the VCO. 3.0 GHz max frequency.
28	$\overline{\text{F}}_{\text{in}}$	ALL	Input	Prescaler complementary input. A bypass capacitor in series with a 51 Ω resistor should be placed as close as possible to this pin and be connected directly to the ground plane.
29	GND	ALL		Ground.
30	f _p	ALL	Output	Monitor pin for main divider output. Switching activity can be disabled through enhancement register programming or by floating or grounding V _{DD} pin 31.

Table 1. Pin Descriptions (continued)

Pin No.	Pin Name	Interface Mode	Type	Description
31	V_{DD-f_p}	ALL	(Note 1)	V_{DD} for f_p . Can be left floating or connected to GND to disable the f_p output.
32	Dout	Serial, Parallel	Output	Data Out. The MSEL signal and the raw prescaler output are available on Dout through enhancement register programming.
33	V_{DD}	ALL	(Note 1)	Same as pin 1.
34	Cext	ALL	Output	Logical "NAND" of PD_U and PD_D terminated through an on chip, 2 k Ω series resistor. Connecting Cext to an external capacitor will low pass filter the input to the inverting amplifier used for driving LD.
35	V_{DD}	ALL	(Note 1)	Same as pin 1.
36	PD_D	ALL	Output	PD_D is pulse down when f_p leads f_c .
37	PD_U	ALL		PD_U is pulse down when f_c leads f_p .
38	V_{DD-f_c}	ALL	(Note 1)	V_{DD} for f_c . Can be left floating or connected to GND to disable the f_c output.
39	f_c	ALL	Output	Monitor pin for reference divider output. Switching activity can be disabled through enhancement register programming or by floating or grounding V_{DD} pin 38.
40	GND	ALL		Ground.
41	GND	ALL		Ground.
42	f_r	ALL	Input	Reference frequency input.
43	LD	ALL	Output, OD	Lock detect and open drain logical inversion of CEXT. When the loop is in lock, LD is high impedance, otherwise LD is a logic low ("0").
44	Enh	Serial, Parallel	Input	Enhancement mode. When asserted low ("0"), enhancement register bits are functional.

Note 1: V_{DD} pins 1, 11, 12, 23, 31, 33, 35, and 38 are connected by diodes and must be supplied with the same positive voltage level.
 V_{DD} pins 31 and 38 are used to enable test modes and should be left floating.

Note 2: All digital input pins have 70 k Ω pull-down resistors to ground.

Table 2. Absolute Maximum Ratings

Symbol	Parameter/Conditions	Min	Max	Units
V_{DD}	Supply voltage	-0.3	4.0	V
V_I	Voltage on any input	-0.3	$V_{DD} + 0.3$	V
I_I	DC into any input	-10	+10	mA
I_O	DC into any output	-10	+10	mA
T_{stg}	Storage temperature range	-65	150	°C

Table 3. Operating Ratings

Symbol	Parameter/Conditions	Min	Max	Units
V_{DD}	Supply voltage	2.85	3.15	V
T_A	Operating ambient temperature range	-40	85	°C

Table 4. ESD Ratings

Symbol	Parameter/Conditions	Level	Units
V_{ESD}	ESD voltage (Human Body Model) – Note 1	1000	V

Note 1: Periodically sampled, not 100% tested. Tested per MIL-STD-883, M3015 C2

Electrostatic Discharge (ESD) Precautions

When handling this UltraCMOS™ device, observe the same precautions that you would use with other ESD-sensitive devices. Although this device contains circuitry to protect it from damage due to ESD, precautions should be taken to avoid exceeding the specified rating in Table 4.

Latch-Up Avoidance

Unlike conventional CMOS devices, UltraCMOS™ devices are immune to latch-up.

Table 5. DC Characteristics: $V_{DD} = 3.0\text{ V}$, $-40^\circ\text{ C} < T_A < 85^\circ\text{ C}$, unless otherwise specified

Symbol	Parameter	Conditions	Min	Typ	Max	Units
I_{DD}	Operational supply current; Prescaler disabled Prescaler enabled	$V_{DD} = 2.85\text{ to }3.15\text{ V}$		10 24	31	mA mA
Digital Inputs: All except f_r , F_{in} , $\overline{F_{in}}$						
V_{IH}	High level input voltage	$V_{DD} = 2.85\text{ to }3.15\text{ V}$	$0.7 \times V_{DD}$			V
V_{IL}	Low level input voltage	$V_{DD} = 2.85\text{ to }3.15\text{ V}$			$0.3 \times V_{DD}$	V
I_{IH}	High level input current	$V_{IH} = V_{DD} = 3.15\text{ V}$			+70	μA
I_{IL}	Low level input current	$V_{IL} = 0, V_{DD} = 3.15\text{ V}$	-1			μA
Reference Divider input: f_r						
I_{IHR}	High level input current	$V_{IH} = V_{DD} = 3.15\text{ V}$			+100	μA
I_{ILR}	Low level input current	$V_{IL} = 0, V_{DD} = 3.15\text{ V}$	-100			μA
R0 Input: R_0						
I_{IHR}	High level input current	$V_{IH} = V_{DD} = 3.15\text{ V}$			+70	μA
I_{ILR}	Low level input current	$V_{IL} = 0, V_{DD} = 3.15\text{ V}$	-5			μA
Counter and phase detector outputs: f_c , f_p						
V_{OLD}	Output voltage LOW	$I_{out} = 6\text{ mA}$			0.4	V
V_{OHD}	Output voltage HIGH	$I_{out} = -3\text{ mA}$	$V_{DD} - 0.4$			V
Lock detect outputs: C_{ext} , LD						
V_{OLC}	Output voltage LOW, C_{ext}	$I_{out} = 100\text{ μA}$			0.4	V
V_{OHC}	Output voltage HIGH, C_{ext}	$I_{out} = -100\text{ μA}$	$V_{DD} - 0.4$			V
V_{OLLD}	Output voltage LOW, LD	$I_{out} = 6\text{ mA}$			0.4	V

Table 6. AC Characteristics: $V_{DD} = 3.0\text{ V}$, $-40^\circ\text{ C} < T_A < 85^\circ\text{ C}$, unless otherwise specified

Symbol	Parameter	Conditions	Min	Max	Units
Control Interface and Latches (see Figures 4, 5, 6)					
f_{CLK}	Serial data clock frequency	(Note 1)		10	MHz
t_{CLKH}	Serial clock HIGH time		30		ns
t_{CLKL}	Serial clock LOW time		30		ns
t_{DSU}	Sdata set-up time after Sclk rising edge, D[7:0] set-up time to M1_WR, M2_WR, A_WR, E_WR rising edge		10		ns
$t_{\text{DHL D}}$	Sdata hold time after Sclk rising edge, D[7:0] hold time to M1_WR, M2_WR, A_WR, E_WR rising edge		10		ns
t_{PW}	S_WR, M1_WR, M2_WR, A_WR, E_WR pulse width		30		ns
t_{CWR}	Sclk rising edge to S_WR rising edge. S_WR, M1_WR, M2_WR, A_WR falling edge to Hop_WR rising edge		30		ns
t_{CE}	Sclk falling edge to E_WR transition		30		ns
t_{WRC}	S_WR falling edge to Sclk rising edge. Hop_WR falling edge to S_WR, M1_WR, M2_WR, A_WR rising edge		30		ns
t_{EC}	E_WR transition to Sclk rising edge		30		ns
t_{MDO}	MSEL data out delay after Fin rising edge	$C_L = 12\text{ pf}$		8	ns
Main Divider (Including Prescaler)					
F_{in}	Operating frequency		500	3000	MHz
P_{Fin}	Input level range	External AC coupling	-5	5	dBm
Main Divider (Prescaler Bypassed)					
F_{in}	Operating frequency		50	300	MHz
P_{Fin}	Input level range	External AC coupling	-5	5	dBm
Reference Divider					
f_r	Operating frequency	(Note 3)		100	MHz
P_{fr}	Reference input power (Note 2)	Single-ended input	-2		dBm
Phase Detector					
f_c	Comparison frequency	(Note 3)		20	MHz

Note 1: Fclk is verified during the functional pattern test. Serial programming sections of the functional pattern are clocked at 10 MHz to verify Fclk specification.

Note 2: CMOS logic levels can be used to drive reference input if DC coupled. Voltage input needs to be a minimum of $0.5V_{pp}$.

Note 3: Parameter is guaranteed through characterization only and is not tested.

Functional Description

The PE9702 consists of a prescaler, counters, a phase detector, and control logic. The dual modulus prescaler divides the VCO frequency by either 10 or 11, depending on the value of the modulus select. Counters “R” and “M” divide the reference and prescaler output, respectively, by integer values stored in a 20-bit register. An additional counter (“A”) is used in the modulus select logic. The phase-frequency detector

generates up and down frequency control signals. The control logic includes a selectable chip interface. Data can be written via serial bus, parallel bus, or hardwired directly to the pins. There are also various operational and test modes and a lock detect output.

Figure 4. Functional Block Diagram

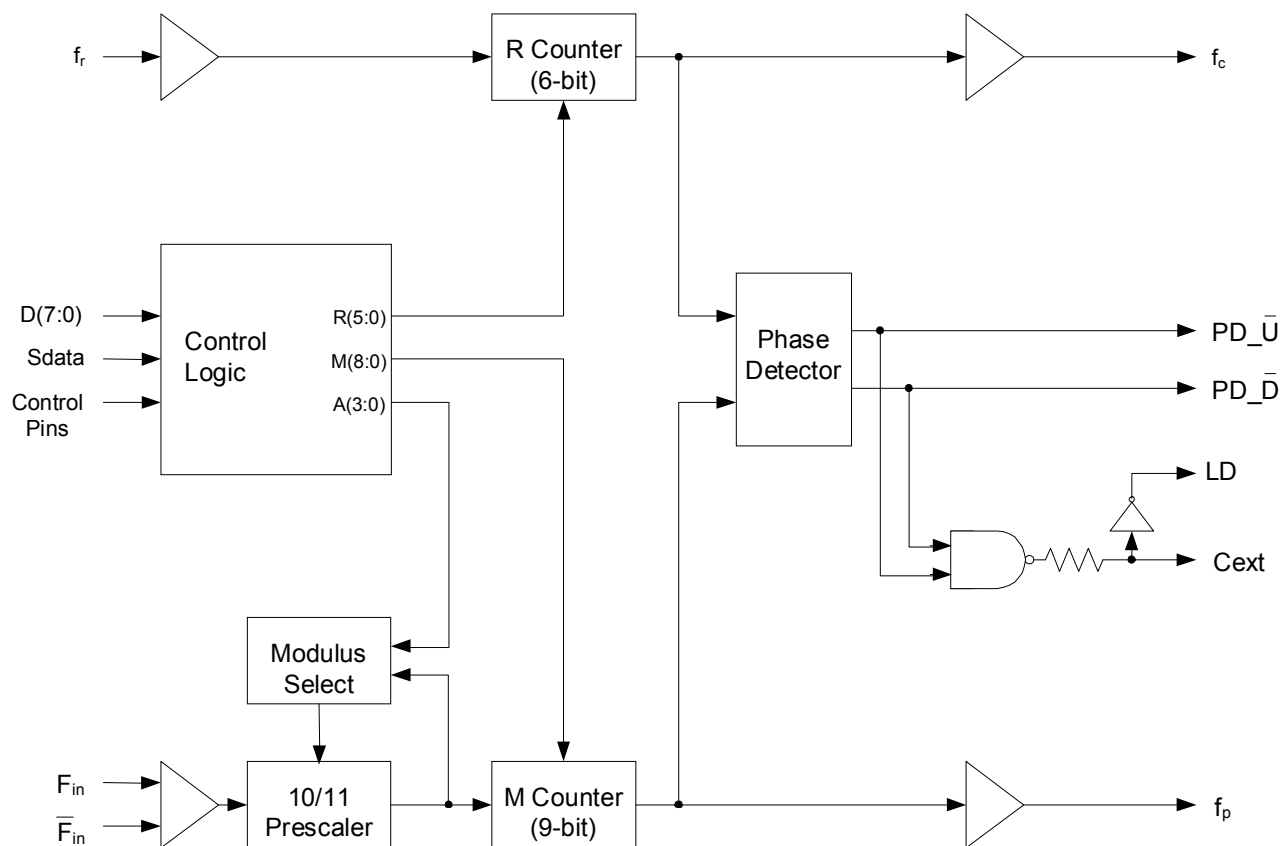

Main Counter Chain

Normal Operating Mode

The main counter chain divides the RF input frequency, F_{in} , by an integer derived from the user-defined values in the “M” and “A” counters. It is composed of the 10/11 dual modulus prescaler, modulus select logic, and 9-bit M counter. Setting $\overline{Pre_en}$ “low” enables the 10/11 prescaler. Setting $\overline{Pre_en}$ “high” allows F_{in} to bypass the prescaler and powers down the prescaler.

The output from the main counter chain, f_p , is related to the VCO frequency, F_{in} , by the following equation:

$$f_p = F_{in} / [10 \times (M + 1) + A] \quad (1)$$

where $A \leq M + 1$, $1 \leq M \leq 511$

When the loop is locked, F_{in} is related to the reference frequency, f_r , by the following equation:

$$F_{in} = [10 \times (M + 1) + A] \times (f_r / (R+1)) \quad (2)$$

where $A \leq M + 1$, $1 \leq M \leq 511$

A consequence of the upper limit on A is that F_{in} must be greater than or equal to $90 \times (f_r / (R+1))$ to obtain contiguous channels. Programming the M Counter with the minimum value of “1” will result in a minimum M Counter divide ratio of “2”.

In Direct Interface Mode, main counter inputs M_7 and M_8 are internally forced low. In this mode, the M value is limited to $1 \leq M \leq 127$.

Prescaler Bypass Mode

Setting $\overline{Pre_en}$ “high” allows F_{in} to bypass and power down the prescaler. In this mode, the 10/11 prescaler and A register are not active, and the input VCO frequency is divided by the M counter directly. The following equation relates F_{in} to the reference frequency, f_r :

$$F_{in} = (M + 1) \times (f_r / (R+1)) \quad (3)$$

where $1 \leq M \leq 511$

In Direct Interface Mode, main counter inputs M_7 and M_8 are internally forced low. In this mode, the M value is limited to $1 \leq M \leq 127$.

Reference Counter

The reference counter chain divides the reference frequency, f_r , down to the phase detector comparison frequency, f_c .

The output frequency of the 6-bit R Counter is related to the reference frequency by the following equation:

$$f_c = f_r / (R + 1) \quad (4)$$

where $0 \leq R \leq 63$

Note that programming R with “0” will pass the reference frequency, f_r , directly to the phase detector.

In Direct Interface Mode, R Counter inputs R_4 and R_5 are internally forced low (“0”). In this mode, the R value is limited to $0 \leq R \leq 15$.

Register Programming

Parallel Interface Mode

Parallel Interface Mode is selected by setting the \overline{Bmode} input “low” and the \overline{Smode} input “low”.

Parallel input data, $D[7:0]$, are latched in a parallel fashion into one of three 8-bit primary register sections on the rising edge of $M1_WR$, $M2_WR$, or A_WR per the mapping shown in Table 7 on page 9. The contents of the primary register are transferred into a secondary register on the rising edge of Hop_WR according to the timing diagram shown in Figure 6. Data is transferred to the counters as shown in Table 7 on page 9.

The secondary register acts as a buffer to allow rapid changes to the VCO frequency. This double buffering for “ping-pong” counter control is programmed via the FSEL \overline{P} input. When FSEL \overline{P} is “high”, the primary register contents set the counter inputs. When FSEL \overline{P} is “low”, the secondary register contents are utilized.

Parallel input data, $D[7:0]$, are latched into the enhancement register on the rising edge of E_WR according to the timing diagram shown in Figure 5. This data provides control bits as shown in Table 8 on page 9 with bit functionality enabled by asserting the \overline{Enh} input “low”.

Serial Interface Mode

Serial Interface Mode is selected by setting the Bmode input “low” and the Smode input “high”. While the E_WR input is “low” and the S_WR input is “low”, serial input data (Sdata input), B₀ to B₁₉, is clocked serially into the primary register on the rising edge of Sclk, MSB (B₀) first. The contents from the primary register are transferred into the secondary register on the rising edge of either S_WR or Hop_WR according to the timing diagram shown in Figure 6. Data is transferred to the counters as shown in Table 7. The double buffering provided by the primary and secondary registers allows for “ping-pong” counter control using the FSELS input. When FSELS is “high”, the primary register contents set the counter inputs. When FSELS is “low”, the secondary register contents are utilized. While the E_WR input is “high” and the S_WR input is “low”, serial input data (Sdata input), B₀ to

B₇, is clocked serially into the enhancement register on the rising edge of Sclk, MSB (B₀) first. The enhancement register is double buffered to prevent inadvertent control changes during serial loading, with buffer capture of the serially-entered data performed on the falling edge of E_WR according to the timing diagram shown in Figure 5. After the falling edge of E_WR, the data provides control bits as shown in Table 8 with bit functionality enabled by asserting the Enh input “low”.

Direct Interface Mode

Direct Interface Mode is selected by setting the Bmode input “high”. Counter control bits are set directly at the pins as shown in Table 7. In Direct Interface Mode, main counter inputs M₇ and M₈, and R Counter inputs R₄ and R₅ are internally forced low (“0”).

Table 7. Primary Register Programming

Interface Mode	Enh	Bmode	Smode	R ₅	R ₄	M ₈	M ₇	Pre_en	M ₆	M ₅	M ₄	M ₃	M ₂	M ₁	M ₀	R ₃	R ₂	R ₁	R ₀	A ₃	A ₂	A ₁	A ₀
Parallel	1	0	0	M2_WR rising edge load				M1_WR rising edge load								A_WR rising edge load							
				D ₃	D ₂	D ₁	D ₀	D ₇	D ₆	D ₅	D ₄	D ₃	D ₂	D ₁	D ₀	D ₇	D ₆	D ₅	D ₄	D ₃	D ₂	D ₁	D ₀
Serial*	1	0	1	B ₀	B ₁	B ₂	B ₃	B ₄	B ₅	B ₆	B ₇	B ₈	B ₉	B ₁₀	B ₁₁	B ₁₂	B ₁₃	B ₁₄	B ₁₅	B ₁₆	B ₁₇	B ₁₈	B ₁₉
Direct	1	1	X	0	0	0	0	Pre_en	M ₆	M ₅	M ₄	M ₃	M ₂	M ₁	M ₀	R ₃	R ₂	R ₁	R ₀	A ₃	A ₂	A ₁	A ₀

*Serial data clocked serially on Sclk rising edge while E_WR “low” and captured in secondary register on S_WR rising edge.



Table 8. Enhancement Register Programming

Interface Mode	Enh	Bmode	Smode	Reserved	Reserved	Reserved	Power down	Counter load	MSEL output	Prescaler output	f _c , f _p OE
Parallel	0	0	0	E_WR rising edge load							
				D ₇	D ₆	D ₅	D ₄	D ₃	D ₂	D ₁	D ₀
Serial*	0	0	1	B ₀	B ₁	B ₂	B ₃	B ₄	B ₅	B ₆	B ₇

*Serial data clocked serially on Sclk rising edge while E_WR “high” and captured in the double buffer on E_WR falling edge.



Figure 5. Parallel Interface Mode Timing Diagram

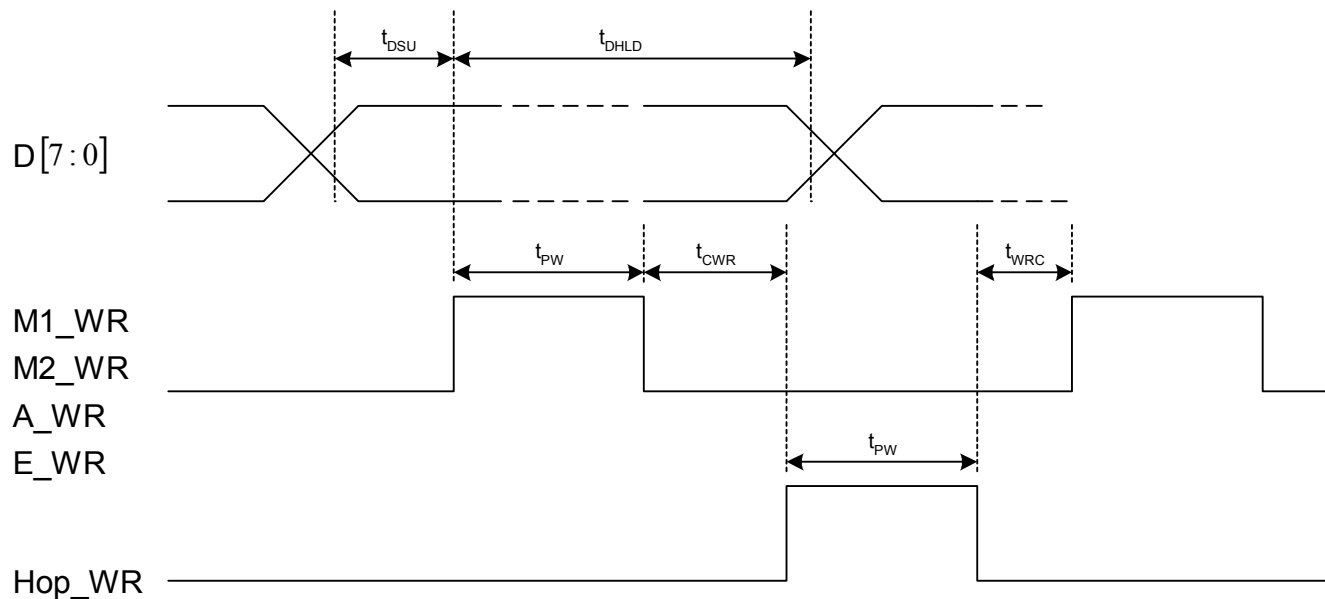
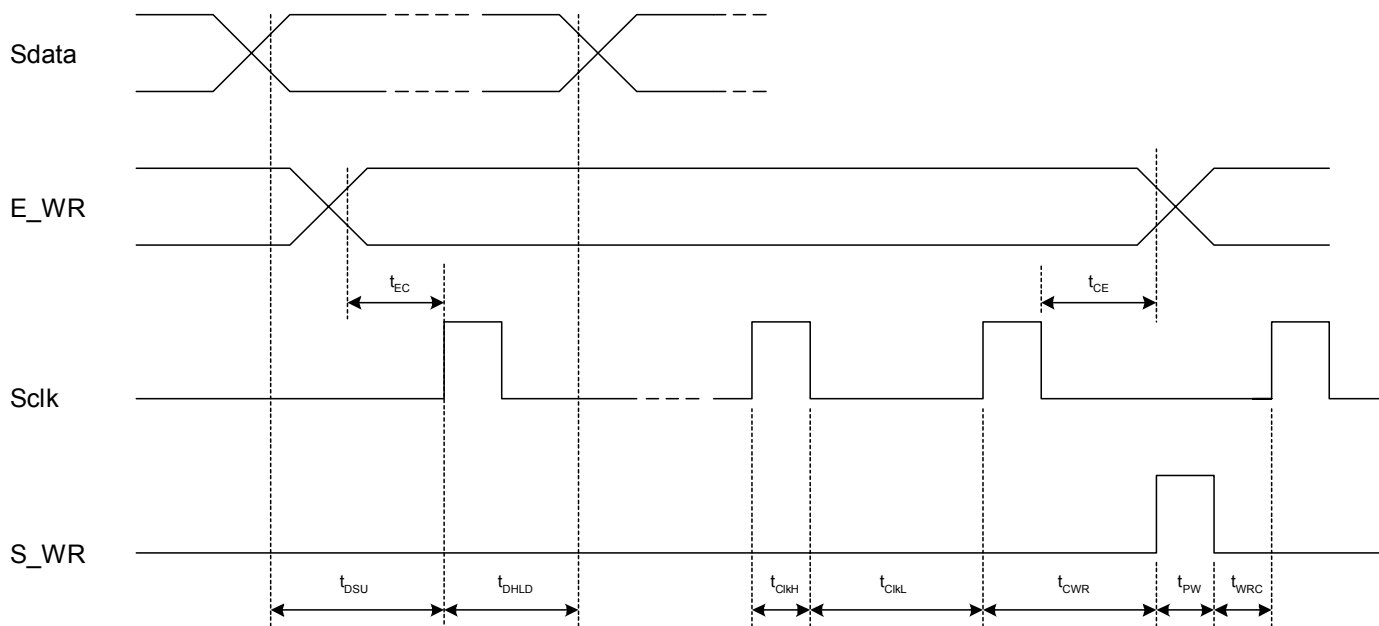

Figure 6. Serial Interface Mode Timing Diagram



Enhancement Register

The functions of the enhancement register bits are shown below with all bits active “high”.

Table 9. Enhancement Register Bit Functionality

Bit Function		Description
Bit 0	Reserved**	
Bit 1	Reserved**	
Bit 2	Reserved**	
Bit 3	Power down	Power down of all functions except programming interface.
Bit 4	Counter load	Immediate and continuous load of counter programming as directed by the \overline{Bmode} and \overline{Smode} inputs.
Bit 5	MSEL output	Drives the internal dual modulus prescaler modulus select (MSEL) onto the Dout output.
Bit 6	Prescaler output	Drives the raw internal prescaler output (fmain) onto the Dout output.
Bit 7	f_p, f_c OE	f_p, f_c outputs disabled.

** Program to 0

Phase Detector

The phase detector is triggered by rising edges from the main Counter (f_p) and the reference counter (f_c). It has two outputs, namely PD_U, and PD_D. If the divided VCO leads the divided reference in phase or frequency (f_p leads f_c), PD_D pulses “low”. If the divided reference leads the divided VCO in phase or frequency (f_r leads f_p), PD_U pulses “low”. The width of either pulse is directly proportional to phase offset between the two input signals, f_p and f_c . The phase detector gain is 430 mV / radian.

PD_U and PD_D are designed to drive an active loop filter which controls the VCO tune voltage.

PD_U pulses result in an increase in VCO frequency and PD_D results in a decrease in VCO frequency.

A lock detect output, LD is also provided, via the pin Cext. Cext is the logical “NAND” of PD_U and PD_D waveforms, which is driven through a series 2k ohm resistor. Connecting Cext to an external shunt capacitor provides integration. Cext also drives the input of an internal inverting comparator with an open drain output. Thus LD is an “AND” function of PD_U and PD_D. See Figure 4 for a schematic of this circuit.

Figure 7. Package Drawing

44-lead CQFJ

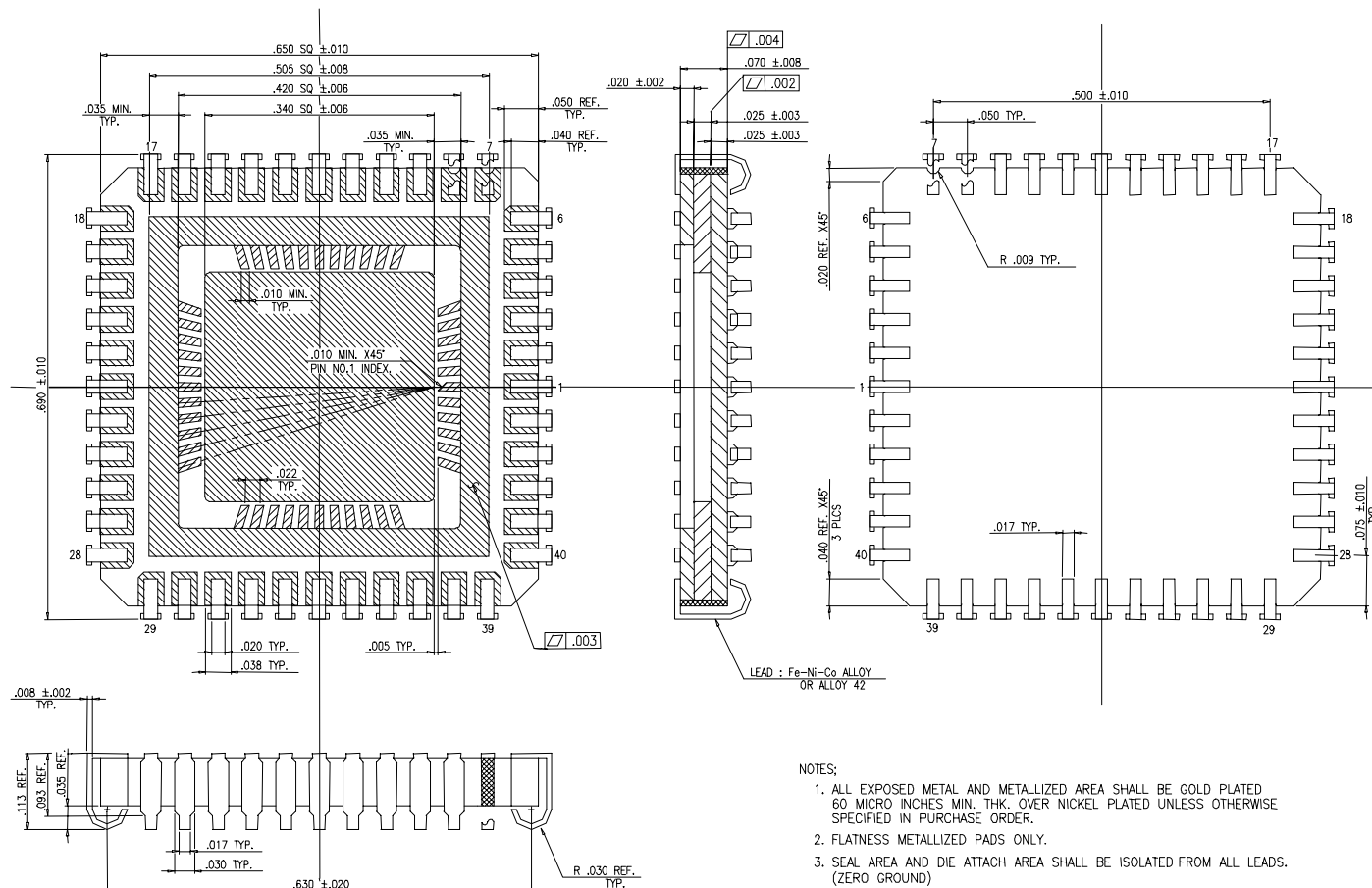

- NOTES:
1. ALL EXPOSED METAL AND METALLIZED AREA SHALL BE GOLD PLATED 60 MICRO INCHES MIN. THK. OVER NICKEL PLATED UNLESS OTHERWISE SPECIFIED IN PURCHASE ORDER.
 2. FLATNESS METALLIZED PADS ONLY.
 3. SEAL AREA AND DIE ATTACH AREA SHALL BE ISOLATED FROM ALL LEADS. (ZERO GROUND)

All dimensions are in mils

Table 10. Ordering Information

Order Code	Part Marking	Description	Package	Shipping Method
9702-01	PE9702 ES	Engineering Samples	44-pin CQFJ	40 units / Tray
9702-11	PE9702	Flight Units	44-pin CQFJ	40 units / Tray
9702-00	PE9702 EK	Evaluation Kit		1 / Box

Sales Offices

The Americas

Peregrine Semiconductor Corporation

9450 Carroll Park Drive
San Diego, CA 92121
Tel: 858-731-9400
Fax: 858-731-9499

Europe

Peregrine Semiconductor Europe

Bâtiment Maine
13-15 rue des Quatre Vents
F-92380 Garches, France
Tel: +33-1-47-41-91-73
Fax : +33-1-47-41-91-73

Space and Defense Products

Americas:

Tel: 858-731-9453

Europe, Asia Pacific:

180 Rue Jean de Guiramand
13852 Aix-En-Provence Cedex 3, France
Tel: +33(0) 4 4239 3361
Fax: +33(0) 4 4239 7227

North Asia Pacific

Peregrine Semiconductor K.K.

Teikoku Hotel Tower 10B-6
1-1-1 Uchisaiwai-cho, Chiyoda-ku
Tokyo 100-0011 Japan
Tel: +81-3-3502-5211
Fax: +81-3-3502-5213

Peregrine Semiconductor, Korea

#B-2402, Kolon Tripolis, #210
Geumgok-dong, Bundang-gu, Seongnam-si
Gyeonggi-do, 463-480 S. Korea
Tel: +82-31-728-4300
Fax: +82-31-728-4305

South Asia Pacific

Peregrine Semiconductor, China

Shanghai, 200040, P.R. China
Tel: +86-21-5836-8276
Fax: +86-21-5836-7652

For a list of representatives in your area, please refer to our Web site at: www.psemi.com

Data Sheet Identification

Advance Information

The product is in a formative or design stage. The data sheet contains design target specifications for product development. Specifications and features may change in any manner without notice.

Preliminary Specification

The data sheet contains preliminary data. Additional data may be added at a later date. Peregrine reserves the right to change specifications at any time without notice in order to supply the best possible product.

Product Specification

The data sheet contains final data. In the event Peregrine decides to change the specifications, Peregrine will notify customers of the intended changes by issuing a DCN (Document Change Notice).

The information in this data sheet is believed to be reliable. However, Peregrine assumes no liability for the use of this information. Use shall be entirely at the user's own risk.

No patent rights or licenses to any circuits described in this data sheet are implied or granted to any third party.

Peregrine's products are not designed or intended for use in devices or systems intended for surgical implant, or in other applications intended to support or sustain life, or in any application in which the failure of the Peregrine product could create a situation in which personal injury or death might occur. Peregrine assumes no liability for damages, including consequential or incidental damages, arising out of the use of its products in such applications.

The Peregrine name, logo, and UTSi are registered trademarks and UltraCMOS and HaRP are trademarks of Peregrine Semiconductor Corp.