



CONNOR-WINFIELD CORPORATION

AURORA, IL. 60505

PHONE (630) 851-4722

FAX (630) 851-5040

HCMOS SURFACE MOUNT OSCILLATORS

SPECIFICATIONS	HSM531S	HSM536S		
Frequency Range	1.8MHz to 80MHz			
Frequency Stability	±100ppm			
	(Inclusive of calibration tolerance at 25°C, operating temperature range, input voltage change, load change, aging, shock and vibration)			
Temperature Range	0°C to +70°C			
Output	Waveform	HCMOS Squarewave		
	Load	15pF	50pF	
	Voltage	Voh	4.5V Minimum	
		Vol	0.5V Maximum	
	Current	Ioh	-16mA	
		Iol	16mA	
	Duty Cycle	48/52 Maximum		
	Rise/Fall Time	5nS Maximum		
Input	Output E/D Time	100nS Maximum		
	Enable	Vih	2.2V Minimum	
		Iih	400uA Maximum , 30uA Typical	
	Disable	Vil	0.8V Maximum	
		Iil	400uA Maximum , 50uA Typical	
Oscillator output is enabled with no connection on pin 1				
Start Up Time	10mS Maximum			
Supply Voltage	+5Vdc ±10%			
Supply Current	1.8MHz to 20MHz: 20mA Maximum 20MHz to 50MHz: 30mA Maximum 50MHz to 70MHz: 50mA Maximum 70MHz to 80MHz: 80mA Maximum			

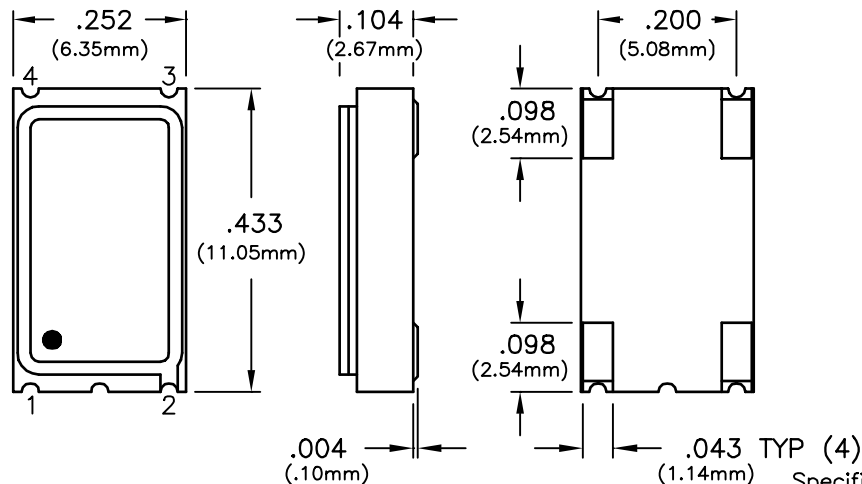

PIN	CONNECTION
1	ENABLE/DISABLE
2	GROUND
3	OUTPUT
4	VDD

Dimensional Tolerance: .005 (.13mm)

ORDERING INFORMATION

HSM531S - 50.00MHz

CLOCK SERIES

CENTER FREQUENCY

Specifications subject to change without notice

BULLETIN #: SM010
PAGE 1 OF 2

REV: 03
DATE: 8/6/01

ISSUED BY: _____



CONNOR-WINFIELD CORPORATION

AURORA, IL. 60505

PHONE (630) 851-4722

FAX (630) 851-5040

OUTPUT WAVEFORM

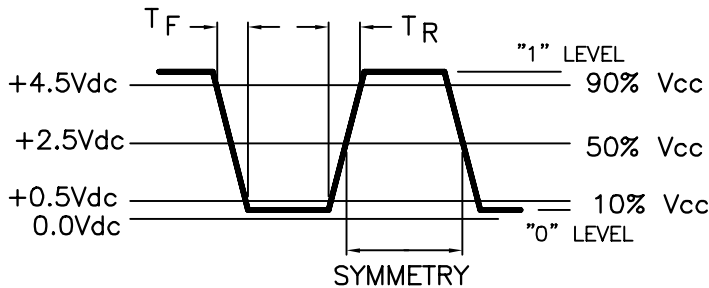

TEST CIRCUIT

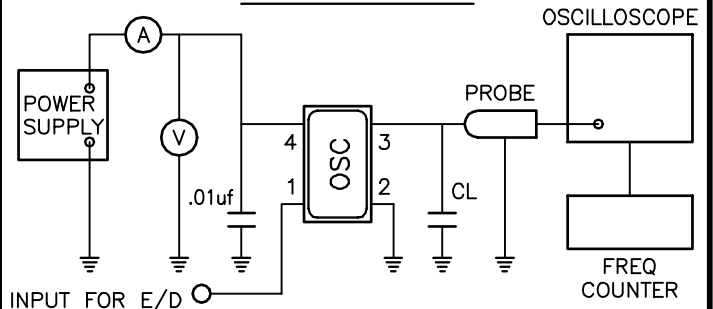

MECHANICAL CHARACTERISTICS

FREE DROP:

The specimen shall meet electrical characteristics after tested 3 times Free Drop testing on the hard wooden board from a height of 75cm.

VIBRATION:

The specimen shall meet electrical characteristics after tested by the following conditions; 10-55Hz 1.5mm Amplitude, 55-2000Hz 20G's, 2 hours for each plane.

THERMAL SHOCK:

After applied Thermal Shock of 260 C max x 10 sec max x 2 times, or 230 C max x 180 sec max, the specimen shall meet electrical characteristics.

SOLDERABILITY: (EIAJ-RCX-0102/101 Condition 1a)

1. Flux: MIL-F-14256 (WW Rosin=25%, Isopropyl alcohol=75%)
2. Solder: QQ-S-571 (Sn=63%, Pb=37%)
3. Solder bath temperature: 235 C +/-5 C.
4. Depth of immersion: Up to electrical terminal.
5. Immersing time: Within 2 sec +/-0.5 sec into solder bath.

After performing the above procedures, a newly soldered coverage shall be greater than 90%.

ENVIRONMENTAL CHARACTERISTICS

TEMPERATURE CYCLE:

The specimen shall meet electrical characteristics after tested 5 cycles of -55 C/30 min & +125 C/30 min.

HERMETICAL

No bubbles appear in Flourinert (FC-43) at 125 C +/-5 C, for 5 minutes.

SOLVENT RESISTANCE:

Marking will withstand immersion in Isopropyl Alcohol or Trichloroethylene.

SOLDERING

GENERAL CONDITIONS:

260°C max x 10 sec max x 2 times max or 230°C max x 180 sec max x 1 time.

TYPICAL OPERATION DATA (Vapor phase reflow)

20 to 100 sec up to 215°C, 50 sec at 215°C then down to room temperature per 1 to 5°C/sec

TAPING AND REEL DIMENSIONS

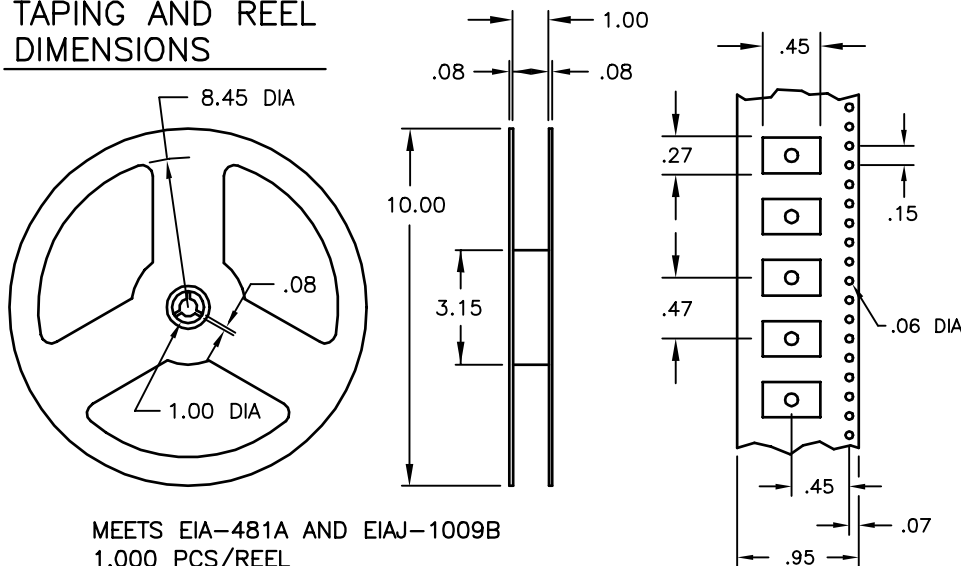

MEETS EIA-481A AND EIAJ-1009B
1,000 PCS/REEL

SUGGESTED PAD LAYOUT

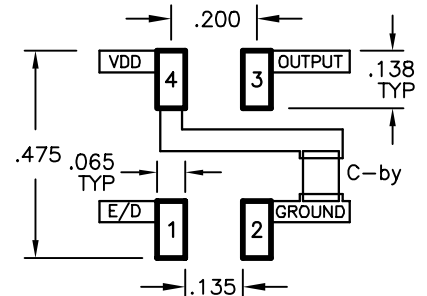

Bypass capacitor, C-by, should be ceramic capacitor $\geq .01\mu\text{f}$.

Specifications subject to change without notice

BULLETIN #: SM010
PAGE 2 OF 2

REV: 03
DATE: 8/6/01

ISSUED BY: _____