



LB8502M — Monolithic Digital IC DC Fan Motor Speed Control IC

Overview

The LB8502M easily and simply implements feedback-based motor speed control in combination with a general-purpose motor driver IC.

Compared to open-loop control, the use of speed feedback allows the motor speed precision to be improved and the speed fluctuations due to load variations to be minimized.

- LB8502M: For use as a driver IC that increases the motor speed as the command voltage rises (three-phase systems)

Features

- Achieves linear speed control
Applications can set the slope of the change in motor speed with change in the input duty.
- Minimized speed fluctuations in the presence of line or load variations
- Allows a minimum speed to be set
- Soft start function
- Settings using external capacitors and resistors (to support easier mass production of end products)
- Supports both PWM duty and analog voltage control inputs

Specifications

Absolute Maximum Ratings at $T_a = 25^\circ\text{C}$

Parameter	Symbol	Conditions	Ratings	Unit
Supply voltage	$V_{CC\ max}$	$V_{CC\ pin}$	18	V
Output current	$I_O\ max$	E0 pin	3	mA
Allowable power dissipation	$P_d\ max$	When mounted on a circuit board *1	0.87	W
Operating temperature	T_{opr}		-30 to +95	$^\circ\text{C}$
Storage temperature	T_{stg}		-55 to +150	$^\circ\text{C}$

*1 Specified circuit board : $114.3 \times 76.1 \times 1.6\text{mm}^3$, glass epoxy.

■ Any and all SANYO Semiconductor Co.,Ltd. products described or contained herein are, with regard to "standard application", intended for the use as general electronics equipment (home appliances, AV equipment, communication device, office equipment, industrial equipment etc.). The products mentioned herein shall not be intended for use for any "special application" (medical equipment whose purpose is to sustain life, aerospace instrument, nuclear control device, burning appliances, transportation machine, traffic signal system, safety equipment etc.) that shall require extremely high level of reliability and can directly threaten human lives in case of failure or malfunction of the product or may cause harm to human bodies, nor shall they grant any guarantee thereof. If you should intend to use our products for applications outside the standard applications of our customer who is considering such use and/or outside the scope of our intended standard applications, please consult with us prior to the intended use. If there is no consultation or inquiry before the intended use, our customer shall be solely responsible for the use.

■ Specifications of any and all SANYO Semiconductor Co.,Ltd. products described or contained herein stipulate the performance, characteristics, and functions of the described products in the independent state, and are not guarantees of the performance, characteristics, and functions of the described products as mounted in the customer's products or equipment. To verify symptoms and states that cannot be evaluated in an independent device, the customer should always evaluate and test devices mounted in the customer's products or equipment.

LB8502M

Allowable Operating Ranges at $T_a = 25^\circ\text{C}$

Parameter	Symbol	Conditions	Ratings	Unit
Supply voltage range 1	V_{CC1}	V_{CC} pin	7.5 to 17	V
Supply voltage range 2	V_{CC2}	V_{CC} pin, with V_{CC} shorted to 6VREG	5.5 to 6.5	V
Output current	I_O	E0 pin	2.5	mA
6V constant voltage output current	I_{REG}		-5	mA
CTL pin voltage	V_{CTL}		0 to VREG	V
LIM pin voltage	V_{LIM}		0 to VREG	V

Electrical Characteristics at $T_a = 25^\circ\text{C}$, $V_{CC} = 12\text{V}$

Parameter	Symbol	Conditions	Ratings			Unit
			min	typ	max	
Supply current	I_{CC}			4.5	6.5	mA
6V constant voltage output (VREG pin)						
Output voltage	VREG		5.8	6.0	6.2	V
Line regulation	ΔV_{REG1}	$V_{CC} = 8$ to 17V		40	100	mV
Load regulation	ΔV_{REG2}	$I_O = 0$ to 5mA		50	100	mV
Temperature coefficient	ΔV_{REG3}	Design target*		0		mV/ $^\circ\text{C}$
Integrating Amplifier Block						
Common-mode input voltage range	VICM		0		VREG - 2.0	V
High-level output voltage	V_{OH}	IEO = -0.2mA	VREG - 1.2	VREG - 0.8		V
Low-level output voltage	V_{OL}	IEO = 0.2mA		0.8	1.0	V
FGIN pin						
High-level input voltage	VFGH		3.0		VREG	V
Low-level input voltage	VFGL		0		1.5	V
Input open voltage	VFGO		VREG - 0.5		VREG	V
Hysteresis	VFGS		0.2	0.25	0.4	V
High-level input current	IFGH	VFGIN = 6VREG	-10	0	10	μA
Low-level input current	IFGL	VFGIN = 0V	-140	-110		μA
RC pin						
High-level output voltage	$V_{OH}(\text{RC})$		3.2	3.45	3.7	V
Low-level output voltage	$V_{OL}(\text{RC})$		0.8	0.95	1.05	V
Clamp voltage	$V_{CLP}(\text{RC})$			1.6		V
CTL pin						
High-level input voltage	VCTH		2.0		VREG	V
Low-level input voltage	VCTL		0		1.0	V
Input open voltage	VCTO		VREG - 0.5		VREG	V
High-level input current	ICTH	VFGIN = 6VREG	-10	0	10	μA
Low-level input current	ICTL	VFGIN = 0V	-140	-110		μA
C pin						
High-level input voltage	$V_{OH}(\text{C})$		3.8	4.0	4.2	V
Low-level input voltage	$V_{OL}(\text{C})$		0.05	0.1	0.2	V
LIM pin						
Input bias current	$I_{B}(\text{LIM})$		-1		0	μA
Common-mode input voltage range	VILIM		0		VREG - 2.0	V

*The design specification items are design guarantees and are not measured.

LB8502M

Package Dimensions

unit : mm (typ)

3086B

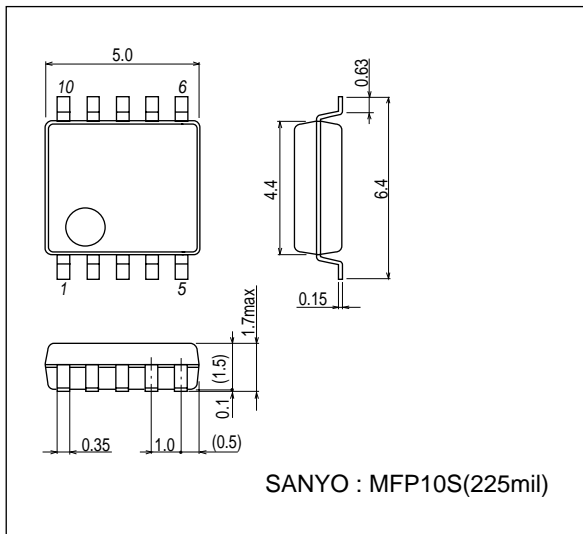

Pin Assignment

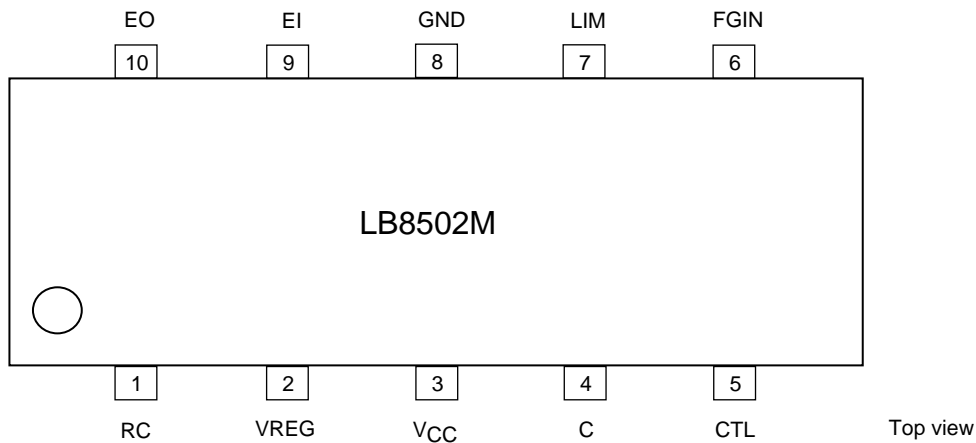

Pin Functions

Pin	Pin No.	Description
1	RC	One-shot multivibrator pulse width setting. Connect a resistor between this pin and VREG, and a capacitor between this pin and ground.
2	VREG	6V regulator output. Connect a capacitor between this pin and ground for stabilization.
3	VCC	Power supply. Connect a capacitor between this pin and ground for stabilization.
4	C	Duty pulse signal smoothing and soft start time setting. Connect a capacitor between this pin and VREG.
5	CTL	Duty pulse signal input. The speed is controlled by the duty of this pulse signal.
6	FGIN	FG pulse input
7	LIM	Minimum speed setting. Normally, the 6V regulator level is resistor divided to set this pin's input level.
8	GND	Ground pin
9	EI	One-shot multivibrator output and integrating amplifier input. A capacitor must be connected between this pin and EO for this integration.
10	EO	Integrating amplifier output.

LB8502M

Block Diagrams and Application Examples

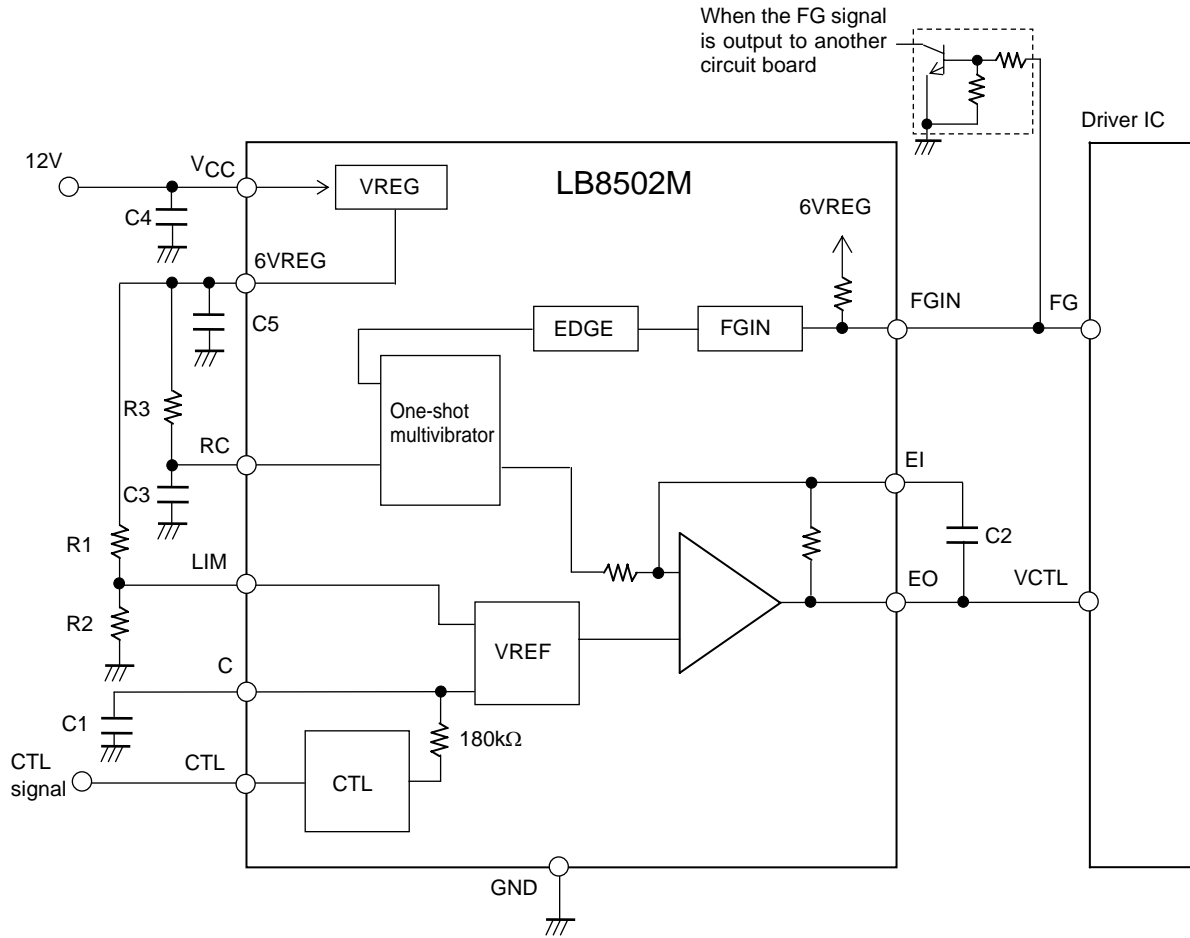

Speed Control Diagrams

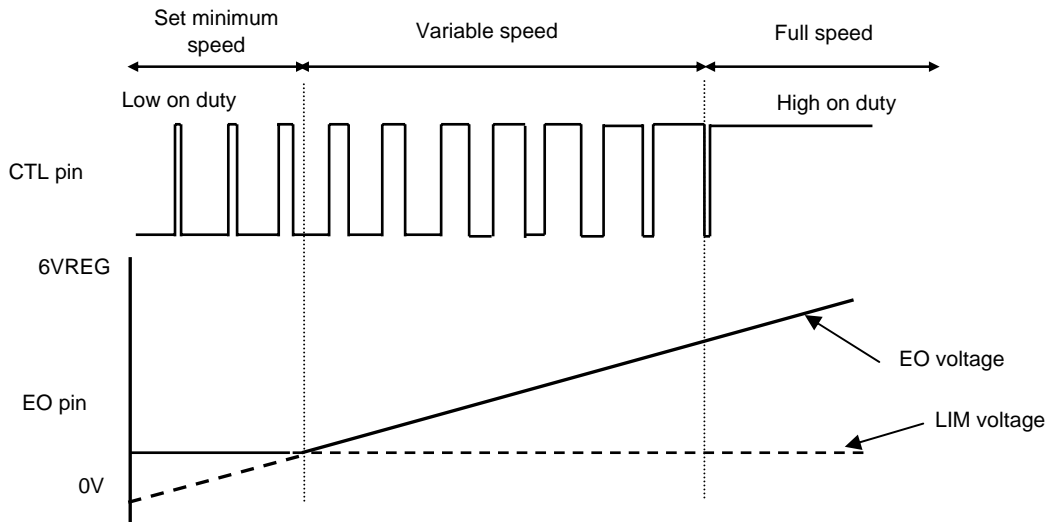
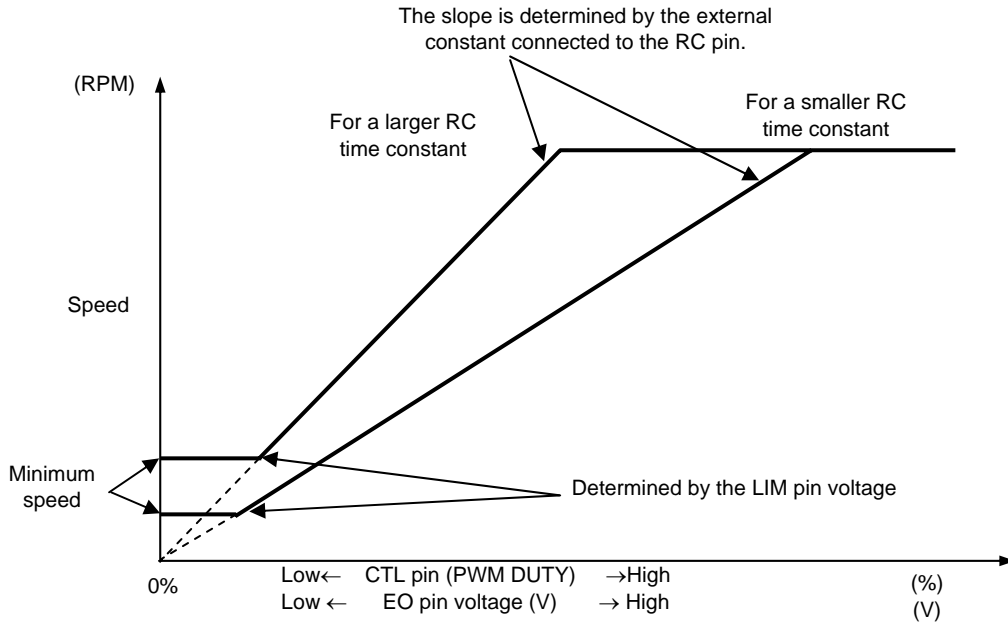

Startup Timing (soft start)

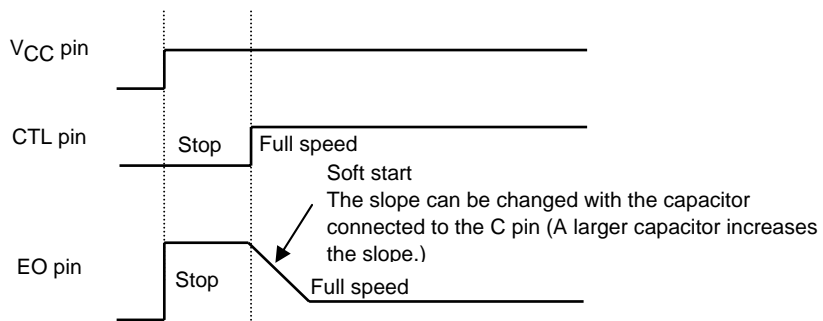

LB8502M

Supplementary Operational Descriptions

The LB8502M accepts a duty pulse input and an FG signal from the driver IC, and generates the driver IC control voltage so that the FG period (motor speed) becomes proportional to the control voltage.

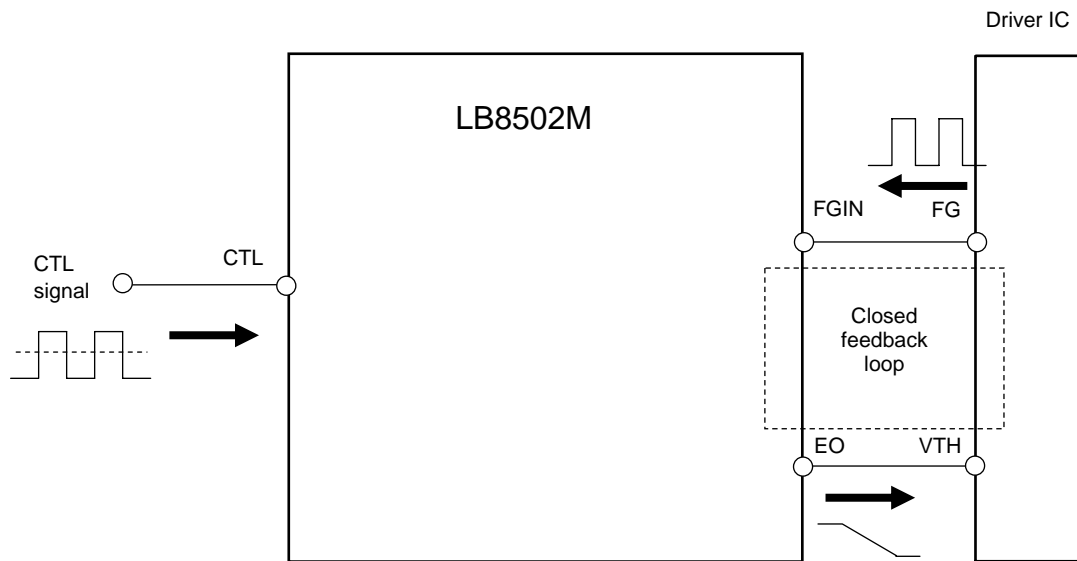

As shown in the figure below, the LB8502M generates a pulse signal from edges on the FG signal and then generates a pulse width waveform determined by the RC time constant in a one-shot multivibrator.

The LB8502M then integrates that pulse waveform to create the output driver IC control voltage (a DC voltage).

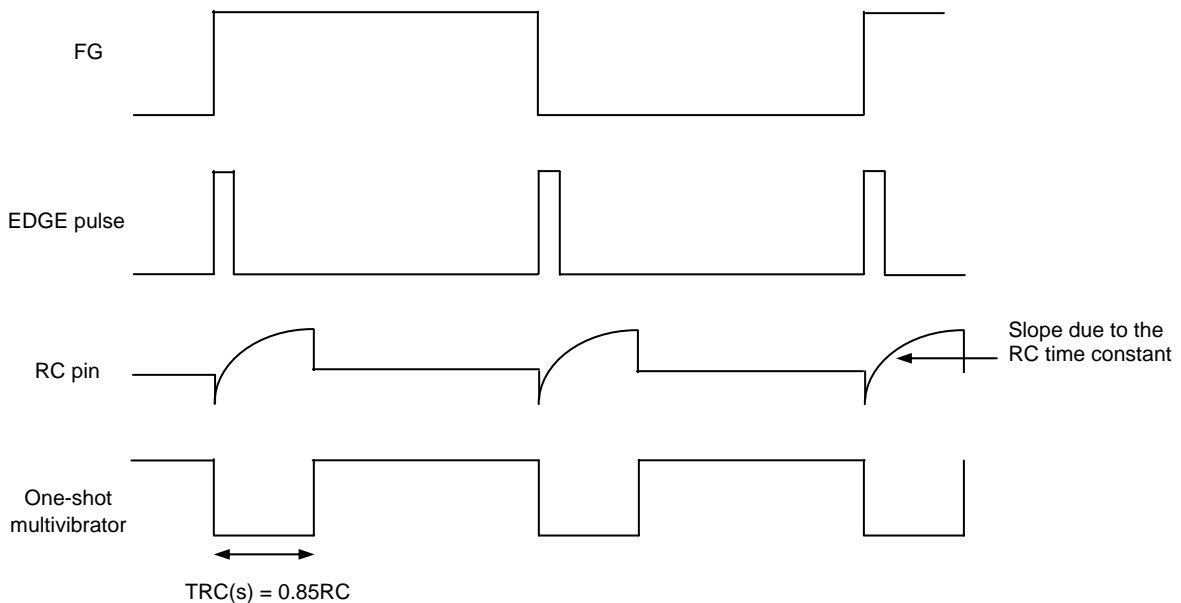

It is also possible to change the slope of the VCTL/speed relationship as shown in the speed control diagram in the previous section by changing the pulse width with the RC time constant.

Note, however, that since pulses determined by this RC time constant are used, variation in the RC components will appear as speed control errors.

Pin Setting Procedures (Provided for reference purposes)

1. RC pin

The one-shot multivibrator pulse width can be calculated with the following equation.

$$TRC(s) \approx 0.85 \times R \times C \dots\dots\dots \text{Equation 1}$$

If the FG signal frequency at full motor speed is fFG (Hz) and the control duty desired for full speed is DUTY (for example: 50% → 0.5), the values of the resistor and capacitor connected to the RC pin can be determined from the following equation.

$$R \times C = DUTY / (3 \times 0.85 \times fFG) \dots\dots\dots \text{Equation 2}$$

Note that if "rpm" is the full motor speed, since one revolution will be two FG periods, the following equation gives the FG frequency, fFG (Hz).

$$fFG(Hz) = 2rpm/60 \dots\dots\dots \text{Equation 3}$$

For reference purposes, the following table lists the RC pin external component values determined from equations 2 and 3 when the control duty at full speed will be 80% for a variety of full motor speed values.

Note that the capacitor value must be in the range 0.01μF to 0.015μF due to the RC pin discharge capacity of the IC.

Full motor speed	R × C	R	C
1000rpm	0.94×10^{-3}	63kΩ	0.015μF
800rpm	1.18×10^{-3}	78kΩ	0.015μF
600rpm	1.57×10^{-3}	105kΩ	0.015μF
400rpm	2.39×10^{-3}	157kΩ	0.015μF
200rpm	4.68×10^{-3}	312kΩ	0.015μF

The table below lists the RC pin external component values when the control duty for full motor speed is changed for a full motor speed of 10,000rpm.

Duty at full speed	R × C	R	C
80% (= 0.8)	0.94×10^{-3}	94kΩ	0.01μF
60% (= 0.6)	0.71×10^{-3}	71kΩ	0.01μF
40% (= 0.4)	0.47×10^{-3}	47kΩ	0.01μF

Also, note that the FG frequency can be determined from the following equation for various control duty input states.

$$fFG = DUTY / (3 \times 0.85 \times RC) \dots\dots\dots \text{Equation 4}$$

2. C Pin

Since a capacitor that can smooth the pin voltage is connected to the C pin, if the CTL pin input signal frequency is f (Hz), then the capacitor must meet the following condition. (Here, R is the IC internal resistance of 180kΩ (typical).)

$$1/f = t < RC$$

Note that the larger the capacitor, the longer the soft start time will be and its response to changes in the input signal will be slower.

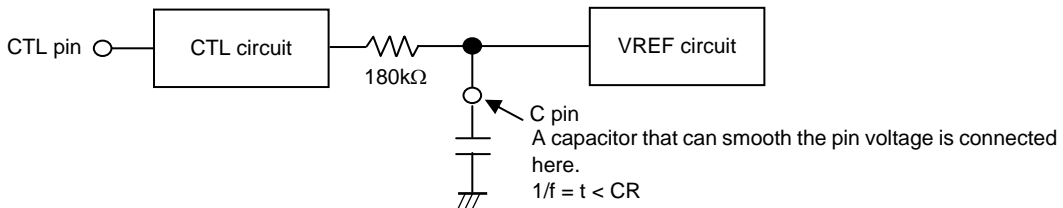

LB8502M

3. LIM pin

The LIM pin external component values can be derived as follows for the case where a motor whose maximum speed of 10,000rpm is to be achieved with an 80% duty, and a minimum speed of 3000rpm is to be set.

$$Ra = \text{minimum speed/full speed} = 3000/10,000 = 0.3$$

$$\text{Full-speed duty} \times Ra = 0.8 \times 0.3 = 0.24$$

$$\text{LIM pin voltage} = 4 \times 0.24 \approx 1V$$

From the above, the required LIM pin voltage is about 1V.

To generate this 1V level by resistor dividing the 6 V regulator level, the resistor ratio will be 5: 1, and the resistors connected to the LIM pin will have the following values.

Between 6VREG and LIM pin : 50k Ω

Between LIM pin and GND : 10k Ω

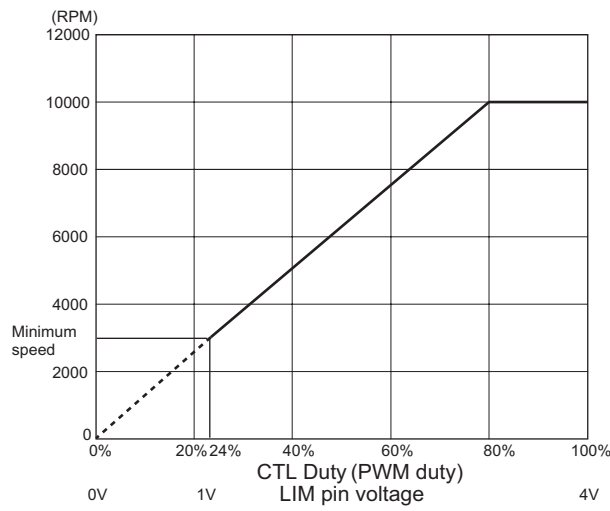

Application Example 2

[Fixed Speed + Soft Start]

With this circuit, the motor speed remains constant even if there are fluctuations in the supply voltage or static voltage.

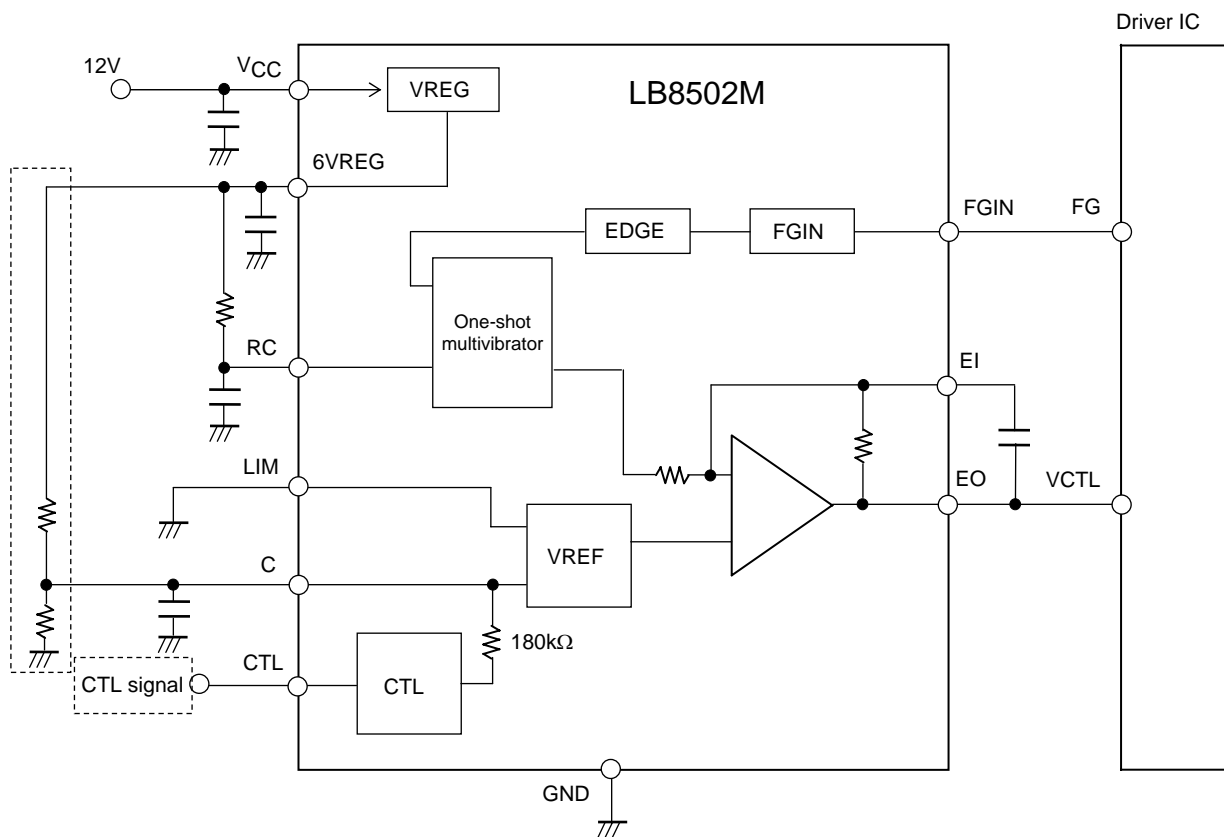
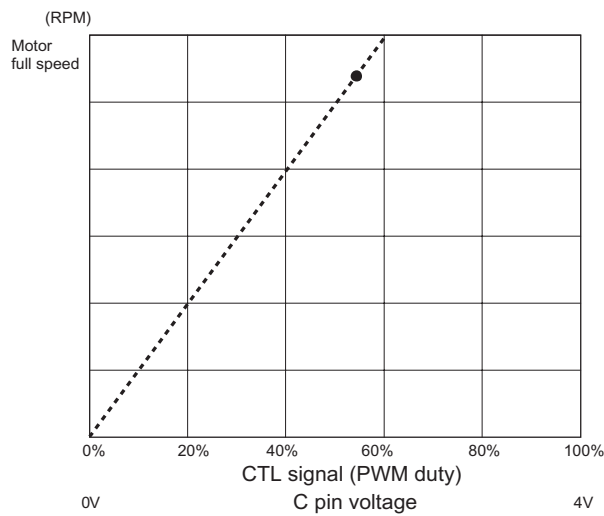

Input a fixed-duty signal to the CTL pin signal input as an input signal for which soft start is enabled at startup. Alternatively, apply a constant voltage to the C pin. (In this case, the CTL pin must be left open.)

LB8502M

Application Example 3

[Analog Input]

DC voltage speed control

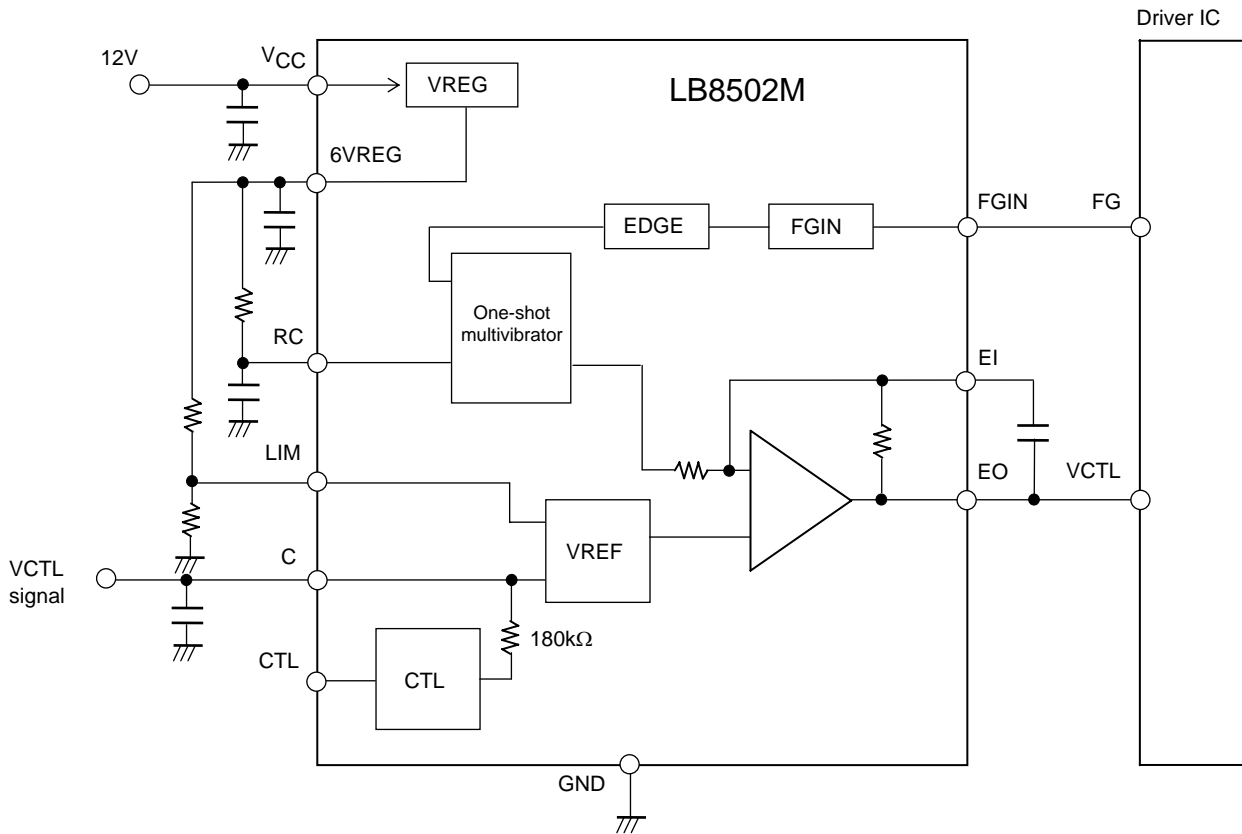
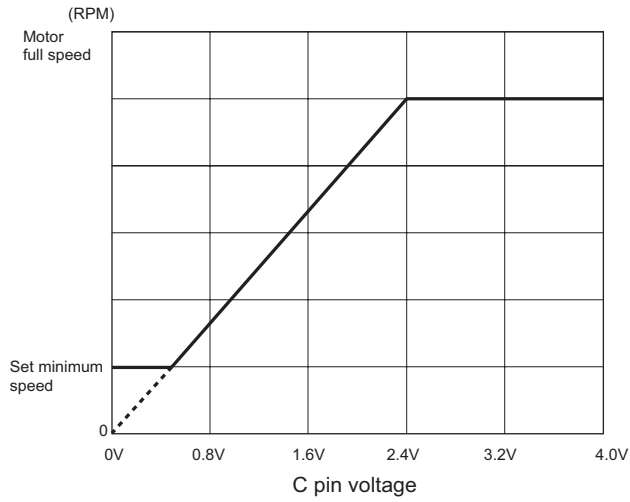

- SANYO Semiconductor Co.,Ltd. assumes no responsibility for equipment failures that result from using products at values that exceed, even momentarily, rated values (such as maximum ratings, operating condition ranges, or other parameters) listed in products specifications of any and all SANYO Semiconductor Co.,Ltd. products described or contained herein.
- SANYO Semiconductor Co.,Ltd. strives to supply high-quality high-reliability products, however, any and all semiconductor products fail or malfunction with some probability. It is possible that these probabilistic failures or malfunction could give rise to accidents or events that could endanger human lives, trouble that could give rise to smoke or fire, or accidents that could cause damage to other property. When designing equipment, adopt safety measures so that these kinds of accidents or events cannot occur. Such measures include but are not limited to protective circuits and error prevention circuits for safe design, redundant design, and structural design.
- In the event that any or all SANYO Semiconductor Co.,Ltd. products described or contained herein are controlled under any of applicable local export control laws and regulations, such products may require the export license from the authorities concerned in accordance with the above law.
- No part of this publication may be reproduced or transmitted in any form or by any means, electronic or mechanical, including photocopying and recording, or any information storage or retrieval system, or otherwise, without the prior written consent of SANYO Semiconductor Co.,Ltd.
- Any and all information described or contained herein are subject to change without notice due to product/technology improvement, etc. When designing equipment, refer to the "Delivery Specification" for the SANYO Semiconductor Co.,Ltd. product that you intend to use.
- Information (including circuit diagrams and circuit parameters) herein is for example only; it is not guaranteed for volume production.
- Upon using the technical information or products described herein, neither warranty nor license shall be granted with regard to intellectual property rights or any other rights of SANYO Semiconductor Co.,Ltd. or any third party. SANYO Semiconductor Co.,Ltd. shall not be liable for any claim or suits with regard to a third party's intellectual property rights which has resulted from the use of the technical information and products mentioned above.

This catalog provides information as of March, 2007. Specifications and information herein are subject to change without notice.