

## 500mA LED PROTECTOR

### DESCRIPTION

The AMC7169 is a two terminal LED protector with low dropout voltage rated for 500mA bypass current. Low operation current at monitoring mode and high bypass current capability at triggered mode. Build-in reverse diode for bypass reversed supply voltage.

The AMC7169 is designed for parallel connection with power LED. It bypasses LED driving current when LED at open circuit condition. It also bypasses LED driving current at reverse connected driving current to LED.

### FEATURES

- 5V Protection Trigger Voltage
- 500mA Bypass Current Capability
- 1V Bypass Dropout Voltage
- 500mA Reverse Current Capability
- 8KV ESD Protection
- 2-Lead 2mm x 2mm FBP Package

### APPLICATIONS

- LED Lighting
- LED backlight for LCD TV/ Monitor
- High Power LED Protection

### PACKAGE PIN OUT

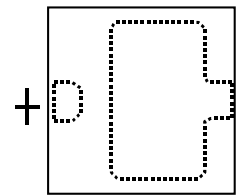

2-Pin 2x2 FBP  
(Top View)

### TYPICAL APPLICATION

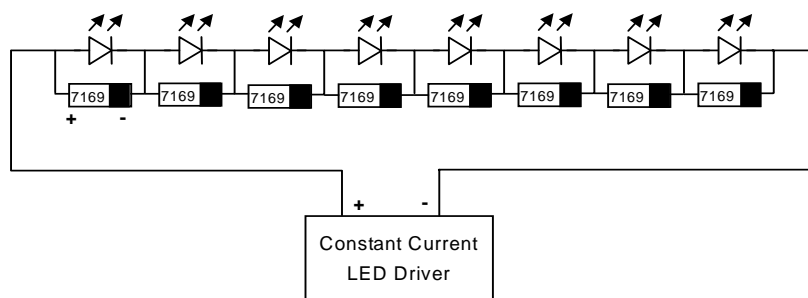

### ORDER INFORMATION

|   |                              |         |
|---|------------------------------|---------|
| T <sub>A</sub> ( °C )   | <b>W</b>                     | 2x2 FBP |
|   |                              | 2-pin   |
| <b>-40 to 85</b>  | <b>AMC7169WF (Lead Free)</b> |         |
| Note: 1. All surface-mount packages are available in Tape & Reel. Append the letter "T" to part number (i.e. AMC7169WFT).<br>2. The letter "F" is marked for Lead Free process. |                              |         |

**ABSOLUTE MAXIMUM RATINGS** (Note)

|   |                |
|---|----------------|
| Input Voltage, $V_{AC}$                       | 40V            |
| Maximum Operating Junction Temperature, $T_J$ | 150°C          |
| Storage Temperature Range                     | -65°C to 150°C |
| Lead Temperature (soldering, 10 seconds)      | 260°C          |

Note: Exceeding these ratings could cause damage to the device. All voltages are with respect to Ground. Currents are positive into, negative out of the specified terminal.

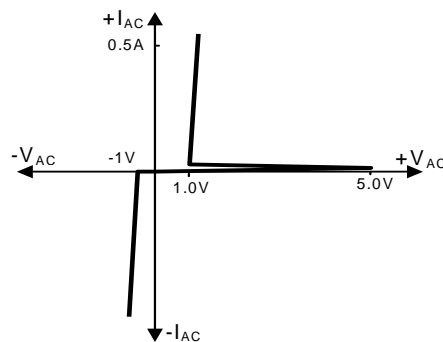
**I-V CURVE**

**RECOMMENDED OPERATING CONDITIONS**

| Parameter                                    | Symbol   | Min. | Typ. | Max. | Units |
|--|----------|------|------|------|-------|
| Input Voltage                                | $V_{AC}$ |      |      | 38   | V     |
| By pass Current (with adequate heat sinking) | $I_{BP}$ |      |      | 500  | mA    |
| Reverse Current                              | $I_R$    |      |      | 500  | mA    |
| Operating ambient temperature range          | $T_A$    | -40  |      | 85   | °C    |
| Operating junction temperature               | $T_J$    |      |      | 125  | °C    |

**ELECTRICAL CHARACTERISTICS**

Unless otherwise specified,  $T_A=25^\circ\text{C}$ , and are for DC characteristics only. (Low duty cycle pulse testing techniques are used which maintains junction and case temperatures equal to the ambient temperature.)

| Parameter                | Symbol    | Conditions            | Min  | Typ | Max  | Units |
|--------------------------|-----------|-----------------------|------|-----|------|-------|
| Trigger Voltage          | $V_{TR}$  |                       | 4.65 | 4.9 | 5.15 | V     |
| Drop-out Voltage         | $V_{DO}$  | $I_{AC}=350\text{mA}$ |      | 1   | 1.2  | V     |
| Reverse Drop-out Voltage | $V_{RDO}$ | $I_R=350\text{mA}$    |      | 1.1 | 1.3  | V     |
| Monitoring Current       | $I_{MAC}$ | $V_{AC}=3.5\text{V}$  |      | 100 | 150  | uA    |
| Break-over Current       | $I_{BAC}$ |                       |      |     | 20   | mA    |
| Trigger Delay Time       | $t_D$     | $I_{AC}=350\text{mA}$ |      | 100 |      | nS    |

**APPLICATION INFORMATION**
**Monitoring Mode:**

The forward voltage drop ( $V_f$ ) of all LEDs should be less than 4V, which is lower than AMC7169 trigger voltage 5.0V. All AMC7169 at monitoring mode would only sink  $\sim\mu\text{A}$  current from the system.

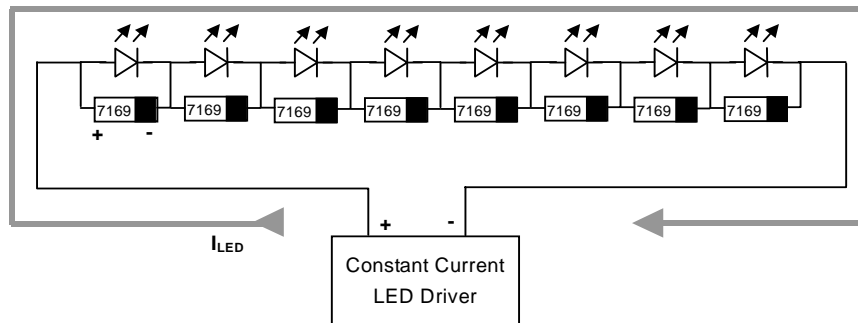
**Triggered Mode:**

Any LED may become open circuit because of LED damage or wiring problem. When it happens, the voltage drop across adjacent AMC7169 starts to increase, and then AMC7169 will be triggered when the voltage drop reaches 5V. The dropout voltage on AMC7169 will be around 1V and the LED current  $I_{LED}$  will be bypassed to next LED. All LEDs will work well except the abnormal LED bypassed.

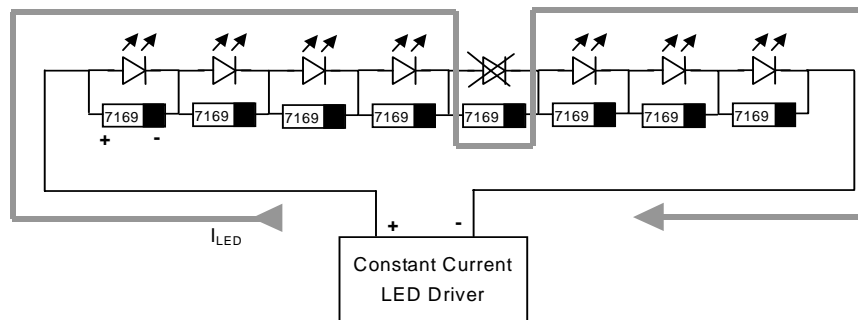

**Reverse Mode:**

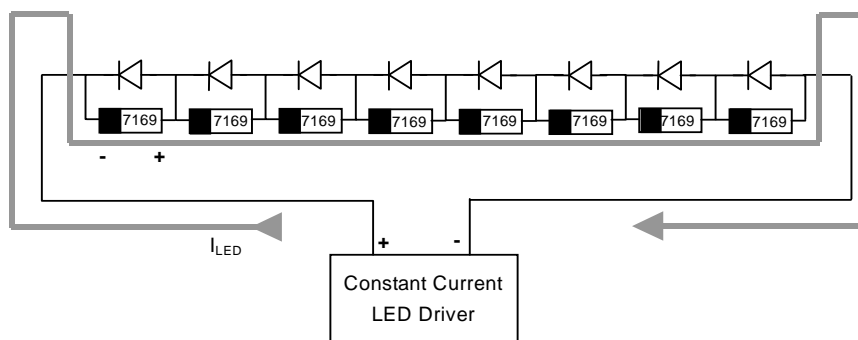
When the LED string was reversed connected to the driver, the AMC7169 build-in reverse protection diode was turned-on to bypass the current. Such that the reverse voltage on LEDs was reduced to prevent LED damage.

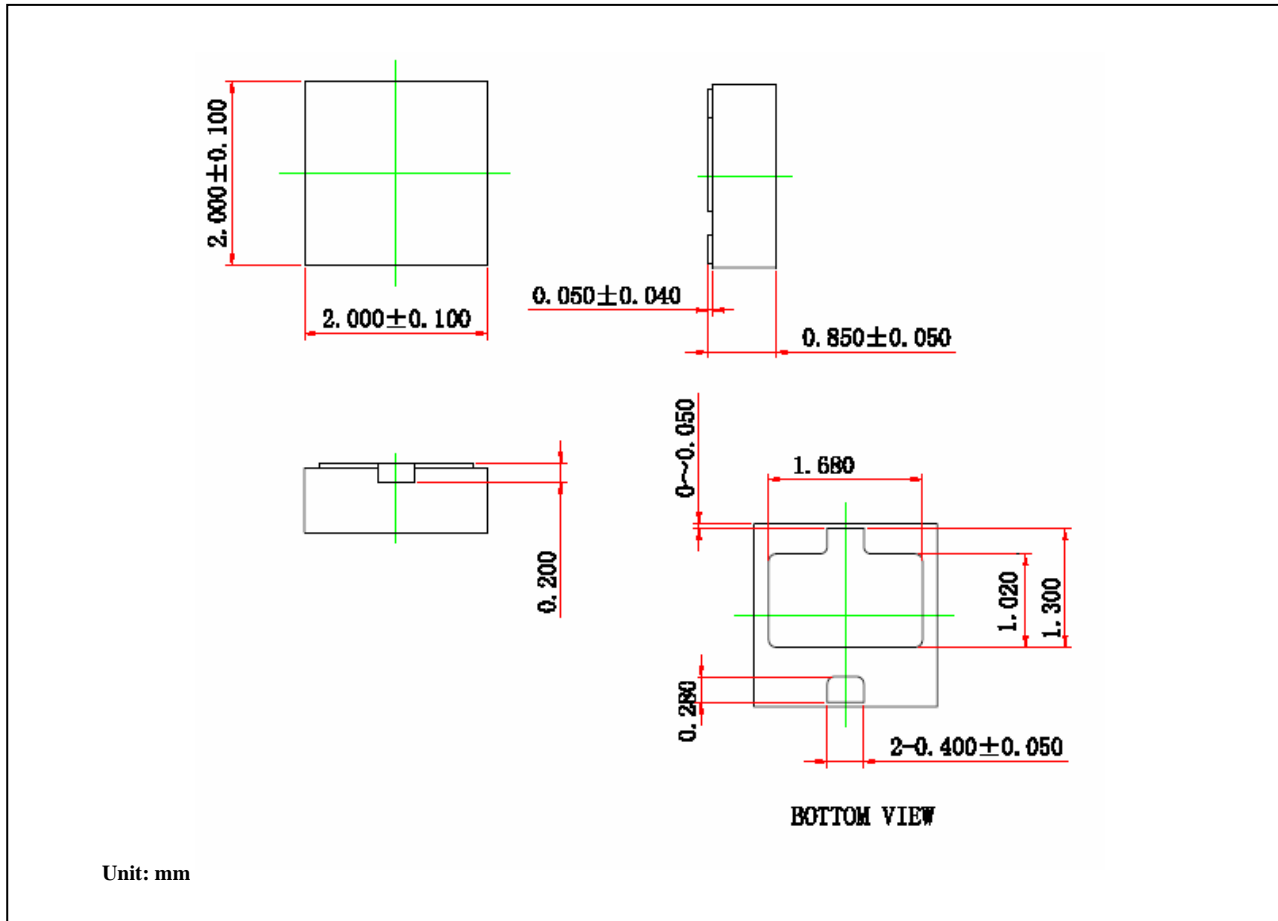

PACKAGE

2x2 FBP



**IMPORTANT NOTICE**

ADDtek reserves the right to make changes to its products or to discontinue any integrated circuit product or service without notice, and advises its customers to obtain the latest version of relevant information to verify, before placing orders, that the information being relied on is current.

A few applications using integrated circuit products may involve potential risks of death, personal injury, or severe property or environmental damage. ADDtek integrated circuit products are not designed, intended, authorized, or warranted to be suitable for use in life-support applications, devices or systems or other critical applications. Use of ADDtek products in such applications is understood to be fully at the risk of the customer. In order to minimize risks associated with the customer's applications, the customer should provide adequate design and operating safeguards.

ADDtek assumes no liability to customer product design or application support. ADDtek warrants the performance of its products to the specifications applicable at the time of sale.

---

**ADDtek Corp.**

9F, No. 20, Sec. 3, Bade Rd., Taipei, Taiwan, 105

TEL: 2-25700299

FAX: 2-25700196

---