

10/100Base-TX Interface Module for NIC/HUB Applications EPF8119S & EPF8119S-RC



- Robust construction allows for toughest soldering processes
- Guaranteed to operate with 8 mA DC bias at 70°C on Cable Side
- Complies with or exceeds IEEE 802.3, 10/100Base-TX Standards
- Wire Insulation Class : MW 80C
- 1500 Vrms Isolation

Electrical Parameters @ 25° C

OCL @ 70°C	Insertion Loss (dB Max.)		Return Loss (dB Min.)			Common Mode Rejection (dB Min.)			Crosstalk (dB Min.) Between Channels	
	1-80 MHz	@ 100 MHz	1-30 MHz	30-60 MHz	60-100 MHz	1-30 MHz	30-100 MHz	100-500 MHz	1-10 MHz	10-100 MHz
100 KHz, 0.1 Vrms 8 mA DC Bias										
Cable Side	Xmit/Rcv	Xmit/Rcv	Xmit/Rcv	Xmit/Rcv	Xmit/Rcv	Xmit/Rcv	Xmit/Rcv	Xmit/Rcv		
350 µH	-1/-1	-1.5/-1.5	-18/-18	-12/-12	-10/-10	-40/-40	-30/-30	-10/-10	-40	-35

• Impedance : 100 Xmit / 100 Rcv • Rise Time : 3.0 nS Max. •

Package

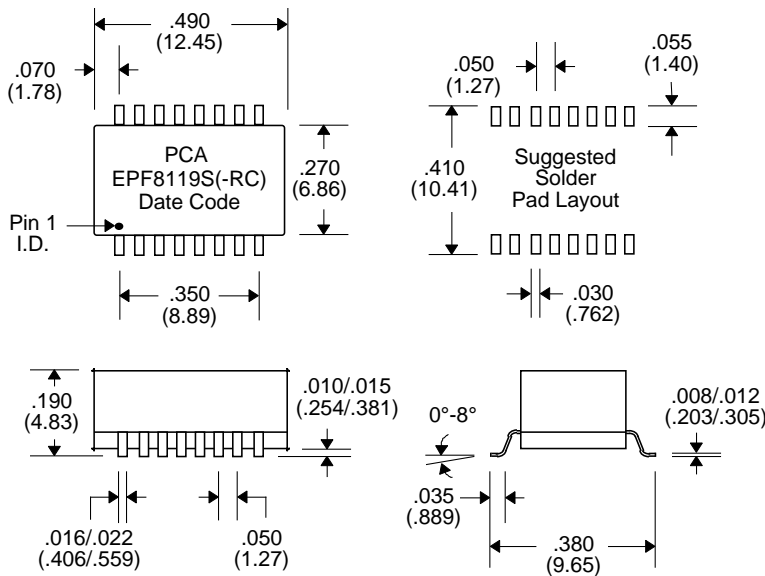

Schematic

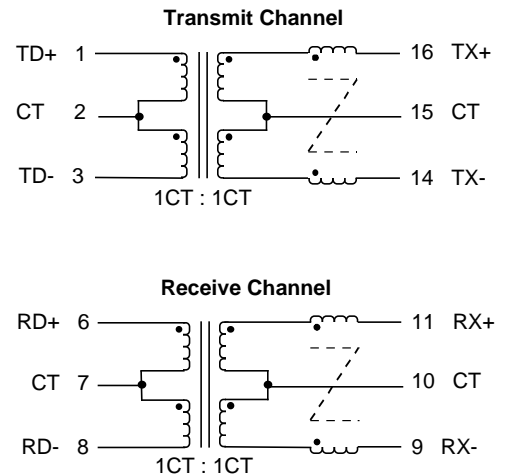

Notes :	EPF8119S	EPF8119S-RC
1. Lead Finish	SnPb	Hot Tin Dip (Sn) †
2. Peak Temperature Rating	225°C	245°C
3. Moisture Sensitive Levels	MSL = 3 (168 Hours, 30°C/60%RH)	MSL = 4 (72 Hours, 30°C/60%RH)
4. Weight	0.92 grams	0.92 grams
5. Packaging Information (Tube)	40 pieces/tube	40 pieces/tube
(*Add "TR" to end of part number, but in front of "-RC" when placing order) (Tape & Reel)	650 pieces/13" reel (*EPF8119STR)	650 pieces/13" reel (*EPF8119STR-RC)

† Lead Material : Matte Tin with Ni Barrier

Unless Otherwise Specified Dimensions are in Inches /mm ± .010 / .25