

HLMP-Cxxx

T-1³/₄ (5 mm) Extra Bright Precision Optical
Performance InGaN LED Lamps



Data Sheet

HLMP-CB11, HLMP-CB12, HLMP-CM11,
HLMP-CM12, HLMP-CE11, HLMP-CE12,
HLMP-CB26, HLMP-CB27, HLMP-CM26,
HLMP-CM27, HLMP-CE26, HLMP-CE27,
HLMP-CB36, HLMP-CB37, HLMP-CM36,
HLMP-CM37, HLMP-CE36, HLMP-CE37

Description

These high intensity blue, green, and cyan LEDs are based on the most efficient and cost effective InGaN material technology. The 470 nm typical dominant wave-length for blue and 525 nm typical wavelength for green is well suited to color mixing in full color signs. The 505 nm typical dominant wavelength for cyan is suitable for traffic signal application.

These LED lamps are untinted, non-diffused, T-1³/₄ packages incorporating second generation optics which produce well-defined spatial radiation patterns at specific viewing cone angles.

These lamps are made with an advanced optical grade epoxy, offering superior temperature and moisture resistance in outdoor signal and sign applications. The high maximum LED junction temperature limit of +110°C enables high temperature operation in bright sunlight conditions.

Features

- Well defined spatial radiation pattern
- High luminous output
- Available in blue, green, and cyan color
- Viewing angle: 15°, 23° and 30°
- Standoff or non-standoff leads
- Superior resistance to moisture

Applications

- Traffic signals
- Commercial outdoor advertising
- Front panel backlighting
- Front panel indicator

CAUTION: Devices are Class I ESD sensitive. Please observe appropriate precautions during handling and processing. Refer to Application Note AN-1142 for additional details.

Package Dimensions

Package A

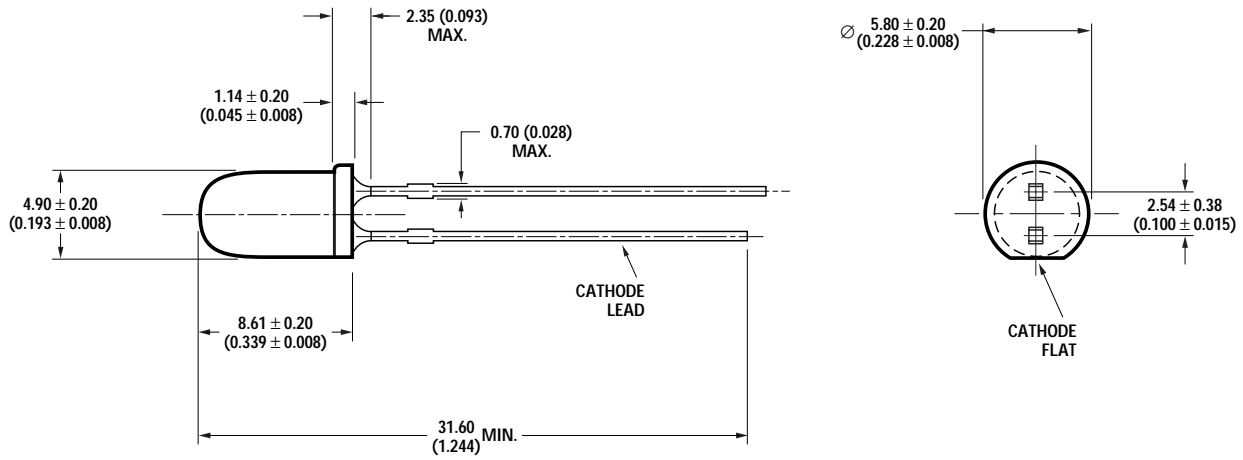

Package B

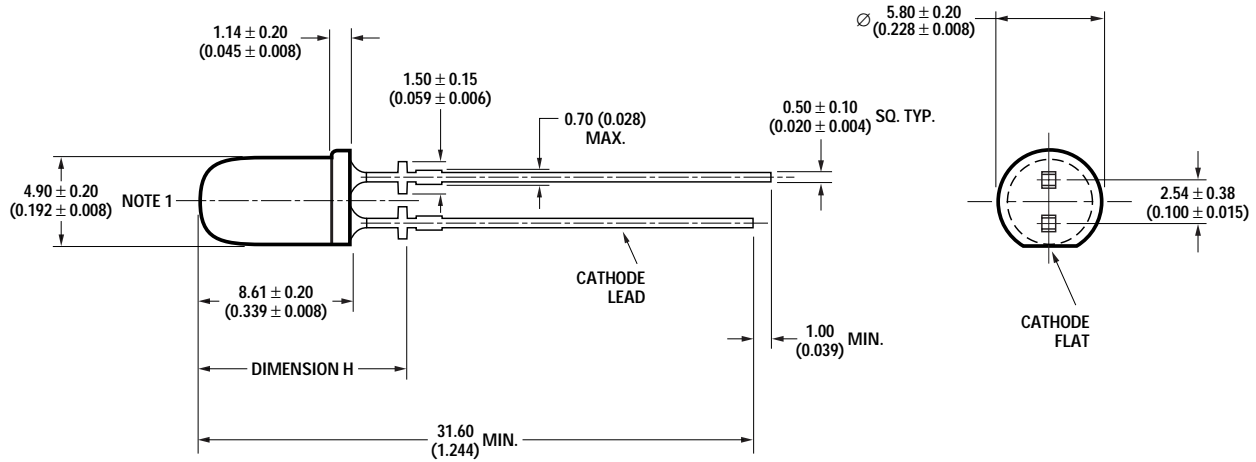

DIMENSION H:	
15°	= 10.80 ± 0.25 mm (0.425 ± 0.01 INCH)
23°	= 10.00 ± 0.25 mm (0.394 ± 0.01 INCH)
30°	= 11.27 ± 0.25 mm (0.444 ± 0.01 INCH)

NOTES:

1. MEASURED JUST ABOVE FLANGE.
2. ALL DIMENSIONS ARE IN MILLIMETERS (INCHES).
3. EPOXY MENISCUS MAY EXTEND ABOUT 1 mm (0.040") DOWN THE LEADS.
4. IF HEAT SINKING APPLICATION IS REQUIRED, THE TERMINAL FOR HEAT SINK IS ANODE.

Device Selection Guide

Part Number	Color	Typical Viewing Angle, $2\theta_{1/2}$ (Degree)	Intensity (cd) at 20 mA		Standoff	Package Dimension	Lens
			Min.	Max.			
HLMP-CB11-TW0xx	Blue	15	2.5	7.2	No	A	Clear
HLMP-CB11-UVAxx	Blue	15	3.2	5.5	No	A	Clear
HLMP-CB12-TW0xx	Blue	15	2.5	7.2	Yes	B	Clear
HLMP-CM11-Y20xx	Green	15	9.3	27.0	No	A	Clear
HLMP-CM11-Z1Cxx	Green	15	12.0	21.0	No	A	Clear
HLMP-CM12-Y20xx	Green	15	9.3	27.0	Yes	B	Clear
HLMP-CE11-X10xx	Cyan	15	7.2	21.0	No	A	Clear
HLMP-CE12-X10xx	Cyan	15	7.2	21.0	Yes	B	Clear
HLMP-CB26-SV0xx	Blue	23	1.9	5.5	No	A	Clear
HLMP-CB26-TUDxx	Blue	23	2.5	4.2	No	A	Clear
HLMP-CB27-SV0xx	Blue	23	1.9	5.5	Yes	B	Clear
HLMP-CM26-X10xx	Green	23	7.2	21.0	No	A	Clear
HLMP-CM26-YZCxx	Green	23	9.3	16.0	No	A	Clear
HLMP-CM27-X10xx	Green	23	7.2	21.0	Yes	B	Clear
HLMP-CE26-WZ0xx	Cyan	23	5.5	16.0	No	A	Clear
HLMP-CE27-WZ0xx	Cyan	23	5.5	16.0	Yes	B	Clear
HLMP-CB36-OT0xx	Blue	30	1.15	3.2	No	A	Clear
HLMP-CB36-RSAxx	Blue	30	1.5	2.5	No	A	Clear
HLMP-CB36-RSBxx	Blue	30	1.5	2.5	No	A	Clear
HLMP-CB37-RU0xx	Blue	30	1.5	4.2	Yes	B	Clear
HLMP-CB37-RSDxx	Blue	30	1.5	2.5	Yes	B	Clear
HLMP-CM36-X10xx	Green	30	7.2	21.0	No	A	Clear
HLMP-CM36-XYCxx	Green	30	7.2	12.0	No	A	Clear
HLMP-CM37-X10xx	Green	30	7.2	21.0	Yes	B	Clear
HLMP-CM37-XYCxx	Green	30	7.2	12.0	Yes	B	Clear
HLMP-CM37-XYDxx	Green	30	7.2	12.0	Yes	B	Clear
HLMP-CE36-WZ0xx	Cyan	30	5.5	16.0	No	A	Clear
HLMP-CE37-WZ0xx	Cyan	30	5.5	16.0	Yes	B	Clear

Notes:

1. Tolerance for luminous intensity measurement is $\pm 15\%$.
2. The luminous intensity is measured on the mechanical axis of the lamp package.
3. The optical axis is closely aligned with the package mechanical axis.
4. LED light output is bright enough to cause injuries to the eyes. Precautions must be taken to prevent looking directly at the LED without proper safety equipment.
5. $2\theta_{1/2}$ is the off-axis angle where the luminous intensity is 1/2 the on-axis intensity.

Part Numbering System

HLMP - x x xx - x x x xx

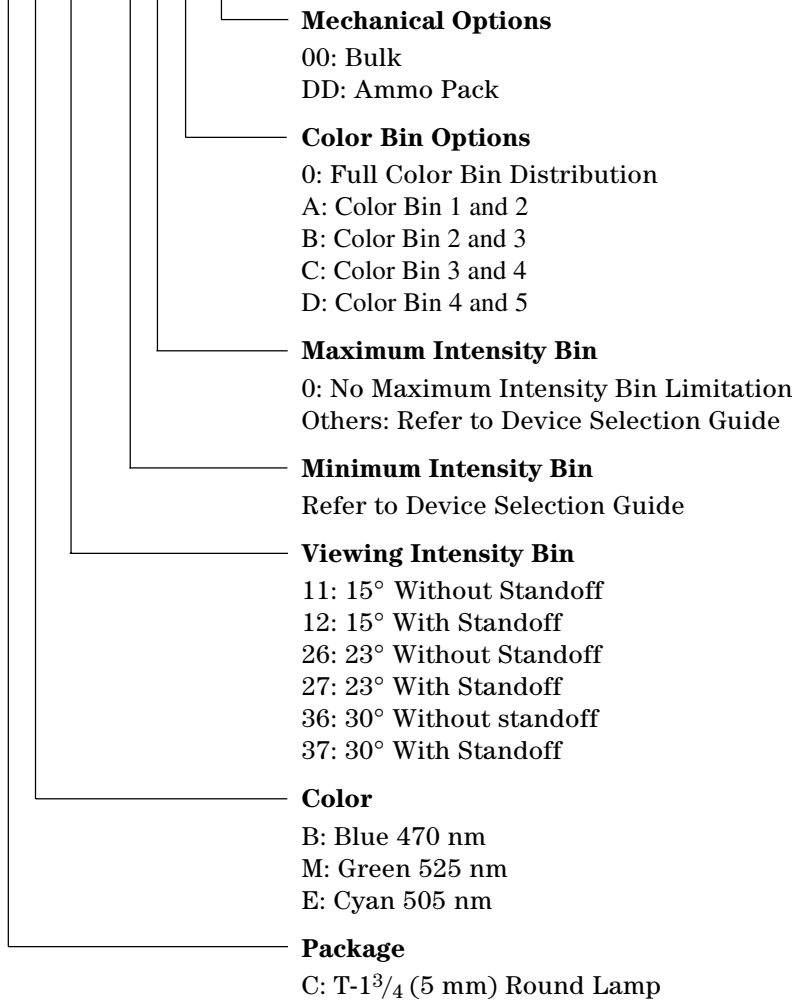

Absolute Maximum Rating at $T_A = 25^\circ\text{C}$

Parameters	Value	Unit
DC Forward Current [1]	30	mA
Peak Pulsed Forward Current[2]	100	mA
Power Dissipation	116	mW
LED Junction Temperature	130	$^\circ\text{C}$
Operating Temperature Range	-40 to +85	$^\circ\text{C}$
Storage Temperature Range	-40 to +100	$^\circ\text{C}$

Notes:

1. Derate linearly as shown in Figure 2.
2. Duty factor 10%, frequency 1 KHz.

Electrical/Optical Characteristics

$T_A = 25^\circ\text{C}$

Parameters	Symbol	Blue			Green			Cyan			Units	Test Condition
		Min.	Typ.	Max.	Min.	Typ.	Max.	Min.	Typ.	Max.		
Forward Voltage	V_F	3.2	3.85		3.3	3.85		3.2	3.85		V	$I_F = 20\text{ mA}$
Reverse Voltage[1]	V_R	5.0			5.0			5.0			V	$I_R = 10\ \mu\text{A}$
Thermal Resistance	$R\theta_{J-PIN}$	240			240			240			$^\circ\text{C}/\text{W}$	LED Junction to Anode Lead
Dominant Wavelength[2]	λ_d	460	470	480	520	525	540	490	505	508	nm	$I_F = 20\text{ mA}$
Peak Wavelength	λ_{PEAK}	464			516			501			nm	Peak of Wavelength of Spectral Distribution at $I_F = 20\text{ mA}$
Spectral Half Width	$\Delta\lambda_{1/2}$	23			32			30			nm	Wavelength Width at Spectral Distribution Power Point at $I_F = 20\text{ mA}$
Luminous Efficacy[3]	η_v	74			484			319			lm/W	Emitted Luminous Power/Emitted Radiant Power

Notes:

1. The reverse voltage of the product is equivalent to the forward voltage of the protective chip at $I_R = 10\ \mu\text{A}$.
2. The dominant wavelength, λ_d , is derived from the Chromaticity Diagram and represents the color of the lamp.
3. The radiant intensity, I_e in watts/steradian, may be found from the equation $I_e = I_v/\eta_v$, where I_v is the luminous intensity in candelas and η_v is the luminous efficacy in lumens/watt.

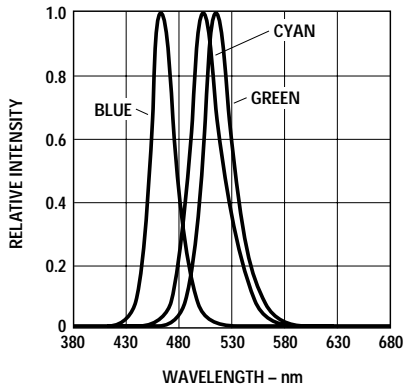

Figure 1. Relative intensity vs. wavelength.

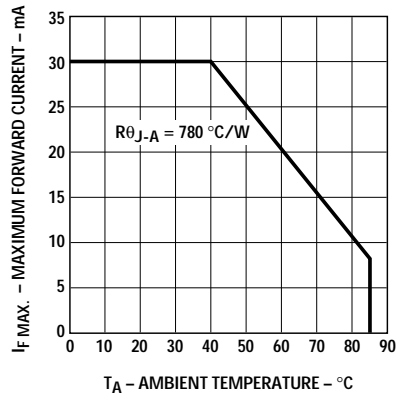

Figure 2. Forward current vs. ambient temperature.

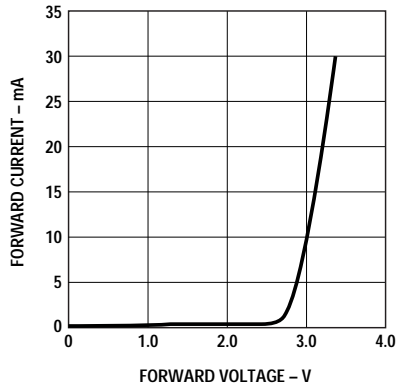

Figure 3. Forward current vs. forward voltage.

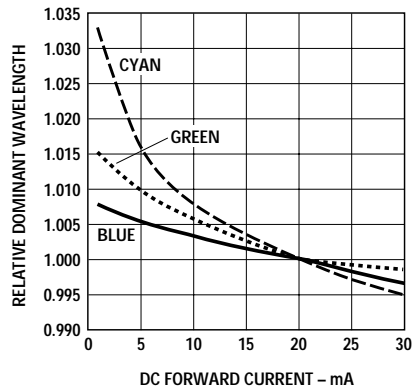

Figure 4. Relative dominant wavelength vs. DC forward current.

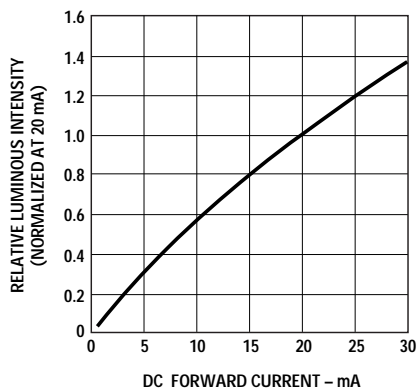

Figure 5. Relative intensity vs. DC forward current.

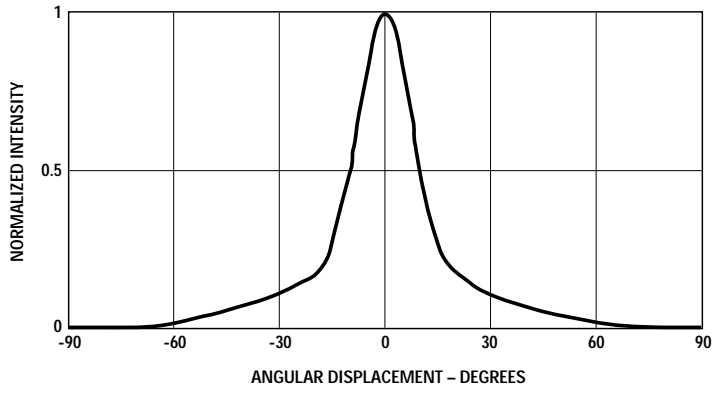

Figure 6. Spatial radiation pattern for Cx11 and Cx12.

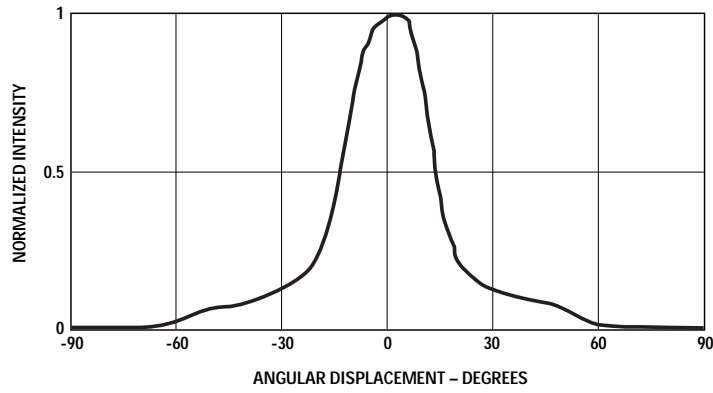

Figure 7. Spatial radiation pattern for Cx26 and Cx27.

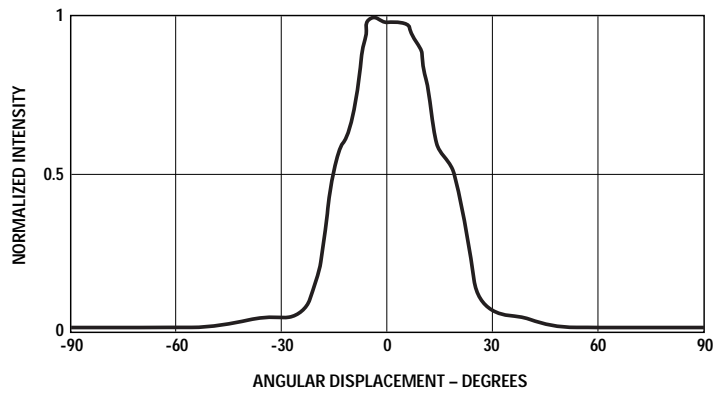

Figure 8. Spatial radiation pattern for Cx36 and Cx37.

Intensity Bin Limit Table

Bin	Intensity (mcd) at 20 mA	
	Min	Max
N	680	880
P	880	1150
Q	1150	1500
R	1500	1900
S	1900	2500
T	2500	3200
U	3200	4200
V	4200	5500
W	5500	7200
X	7200	9300
Y	9300	12000
Z	12000	16000
1	16000	21000

Tolerance for each bin limit is $\pm 15\%$.

Blue Color Bin Table

Bin	Min Dom	Max Dom	Xmin	Ymin	Xmax	Ymax
1	460.0	464.0	0.1440	0.0297	0.1766	0.0966
			0.1818	0.0904	0.1374	0.0374
2	464.0	468.0	0.1374	0.0374	0.1699	0.1062
			0.1766	0.0966	0.1291	0.0495
3	468.0	472.0	0.1291	0.0495	0.1616	0.1209
			0.1699	0.1062	0.1187	0.0671
4	472.0	476.0	0.1187	0.0671	0.1517	0.1423
			0.1616	0.1209	0.1063	0.0945
5	476.0	480.0	0.1063	0.0945	0.1397	0.1728
			0.1517	0.1423	0.0913	0.1327

Tolerance for each bin limit is ± 0.5 nm.

Green Color Bin Table

Bin	Min Dom	Max Dom	Xmin	Ymin	Xmax	Ymax
1	520.0	524.0	0.0743	0.8338	0.1856	0.6556
			0.1650	0.6586	0.1060	0.8292
2	524.0	528.0	0.1060	0.8292	0.2068	0.6463
			0.1856	0.6556	0.1387	0.8148
3	528.0	532.0	0.1387	0.8148	0.2273	0.6344
			0.2068	0.6463	0.1702	0.7965
4	532.0	536.0	0.1702	0.7965	0.2469	0.6213
			0.2273	0.6344	0.2003	0.7764
5	536.0	540.0	0.2003	0.7764	0.2659	0.6070
			0.2469	0.6213	0.2296	0.7543

Tolerance for each bin limit is ± 0.5 nm.

Cyan Color Bin Table

Bin	Min Dom	Max Dom	Xmin	Ymin	Xmax	Ymax
1	490.0	495.0	0.0454	0.2945	0.1164	0.3889
			0.1318	0.306	0.0235	0.4127
2	495.0	500.0	0.0345	0.4127	0.1057	0.4769
			0.1164	0.3889	0.0082	0.5384
3	500.0	505.0	0.0082	0.5384	0.1027	0.5584
			0.1057	0.4769	0.0039	0.6548
4	505.0	510.0	0.0039	0.6548	0.1097	0.6251
			0.1027	0.5584	0.0139	0.7502
7	498.0	503.0	0.0132	0.4882	0.1028	0.5273
			0.1092	0.4417	0.0040	0.6104
8	503.0	508.0	0.0040	0.6104	0.1056	0.6007
			0.1028	0.5273	0.0080	0.7153

Tolerance for each bin limit is ± 0.5 nm.

Precautions

Lead Forming

- The leads of an LED lamp may be preformed or cut to length prior to insertion and soldering into PC board.
- If lead forming is required before soldering, care must be taken to avoid any excessive mechanical stress induced to LED package. Otherwise, cut the leads of LED to length after soldering process at room temperature. The solder joint formed will absorb the mechanical stress of the lead cutting from traveling to the LED chip die attach and wirebond.
- It is recommended that tooling made to precisely form and cut the leads to length rather than rely upon hand operation.

Soldering Conditions

- Care must be taken during PCB assembly and soldering process to prevent damage to LED component.
- The closest LED is allowed to solder on board is 1.59 mm below the body (encapsulant epoxy) for those parts without standoff.
- Recommended soldering conditions:

	Wave Soldering	Manual Solder Dipping
Pre-heat Temperature	105 °C Max.	–
Pre-heat Time	30 sec Max.	–
Peak Temperature	250 °C Max.	260 °C Max.
Dwell Time	3 sec Max.	5 sec Max.

- Wave soldering parameter must be set and maintained according to recommended temperature and dwell time in the solder wave. Customer is advised to periodically check on the soldering profile to ensure the soldering profile used is always conforming to recommended soldering condition.
- If necessary, use fixture to hold the LED component in proper orientation with respect to the PCB during soldering process.
- Proper handling is imperative to avoid excessive thermal stresses to LED components when heated. Therefore, the soldered PCB must be allowed to cool to room temperature, 25° C, before handling.
- Special attention must be given to board fabrication, solder masking, surface plating and lead holes size and component orientation to assure solderability.
- Recommended PC board plated through hole sizes for LED component leads:

LED Component Lead Size	Diagonal	Plated Through Hole Diameter
0.457 x 0.457 mm (0.018 x 0.018 inch)	0.646 mm (0.025 inch)	0.976 to 1.078 mm (0.038 to 0.042 inch)
0.508 x 0.508 mm (0.020 x 0.020 inch)	0.718 mm (0.028 inch)	1.049 to 1.150 mm (0.041 to 0.045 inch)

Note: Refer to application note AN1027 for more information on soldering LED components.

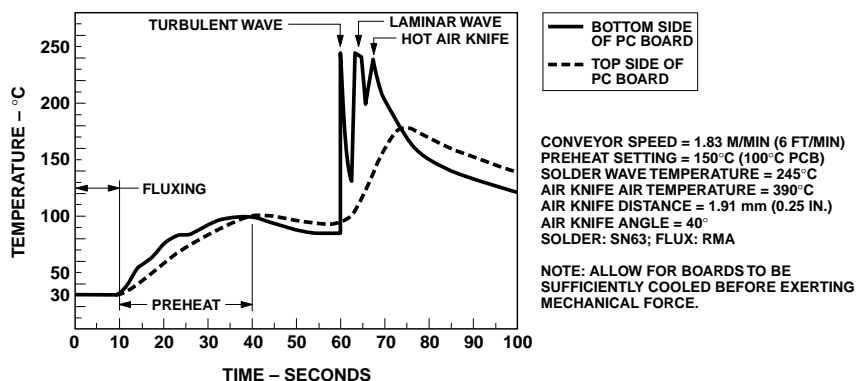

Figure 9. Recommended wave soldering profile.

For product information and a complete list of distributors, please go to our website: www.avagotech.com

Avago, Avago Technologies, and the A logo are trademarks of Avago Technologies Limited in the United States and other countries.
Data subject to change. Copyright © 2006 Avago Technologies Limited. All rights reserved. Obsoletes 5989-3337EN
5989-4115EN June 26, 2006

