

SP6T UltraCMOS™ 2.70 V Switch
100 – 3000 MHz, 50 Ω

Figure 1. Functional Diagram

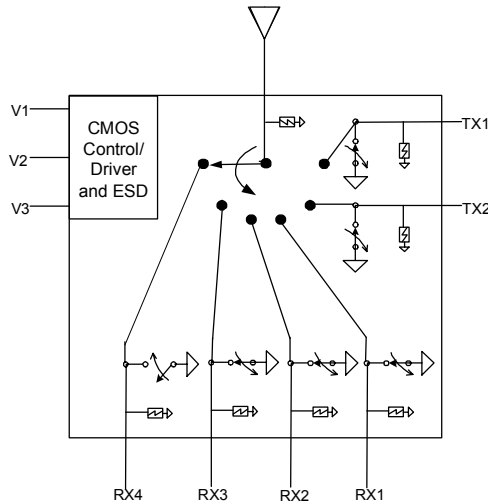

Features

- Three pin CMOS logic control with integral decoder/driver
- Low TX insertion loss: 0.55 dB at 900 MHz, 0.60 dB at 1900 MHz
- TX – RX Isolation of 38 dB at 900 MHz, 31 dB at 1900 MHz
- Low harmonics: $2f_o = -90$ dBc and $3f_o = -82$ dBc
- 1500 V HBM ESD tolerance all ports
- 41 dBm P1dB, TX paths
- No blocking capacitors required
- RoHS compliant lead-free solder balls

Figure 2. Die Top View

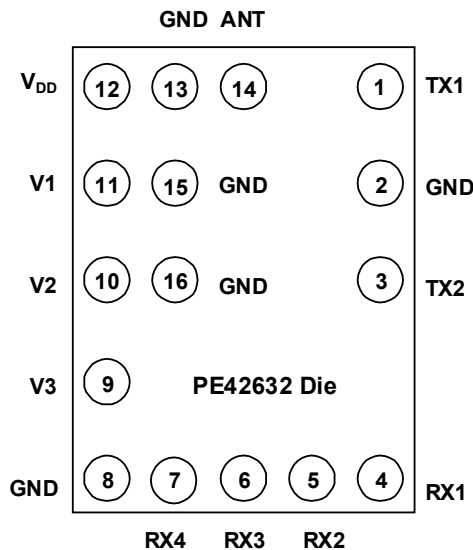
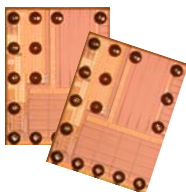

Figure 3. Package Type: Flip Chip



Product Description

The PE42632 is a HaRP™-enhanced SP6T RF Switch developed on the UltraCMOS™ process technology. This 50 Ω switch addresses the specific design needs of the Quad-Band GSM Handset Antenna Switch Module Market. On-chip CMOS decode logic facilitates three-pin low voltage CMOS control. High ESD tolerance of 1500 V at all ports, no blocking capacitor requirements and on-chip SAW filter over-voltage protection devices make this the ultimate in integration and ruggedness.

Peregrine's HaRP™ technology enhancements deliver high linearity and exceptional harmonics performance. It is an innovative feature of the UltraCMOS™ process, providing performance superior to GaAs with the economy and integration of conventional CMOS.

Table 1. Electrical Specifications @ +25 °C, V_{DD} = 2.5 - 2.8 V (Z_S = Z_L = 50 Ω)

Parameter	Conditions	Typical	Units
Operational Frequency		100-3000	MHz
Insertion Loss ¹	ANT - TX - 850 / 900 MHz	0.55	dB
	ANT - TX - 1800 / 1900 MHz	0.6	dB
	ANT - RX - 850 / 900 MHz	0.9	dB
	ANT - RX - 1800 / 1900 MHz	1.15	dB
Isolation	TX - RX - 850 / 900 MHz	38	dB
	TX - RX - 1800 / 1900 MHz	31	dB
	TX - TX - 850 / 900 MHz	31	dB
	TX - TX - 1800 / 1900 MHz	26	dB
Return Loss	850 / 900 MHz	23	dB
	1800 / 1900 MHz	22	dB
2nd Harmonic ^{2,3}	35 dBm TX Input - 850 / 900 MHz	-90	dBc
	33 dBm TX Input - 1800 / 1900 MHz	-89	dBc
3rd Harmonic ^{2,3}	35 dBm TX Input - 850 / 900 MHz	-82	dBc
	33 dBm TX Input - 1800 / 1900 MHz	-80	dBc
Switching Time ⁴	50% Control Logic to 90% RF	1	µs

- Notes:
1. Insertion loss specified with optimal ANT impedance matching.
 2. Measured in Pulsed Wave Mode.
 3. Assumes RF input duty cycle of 50% and 4620 µs, measured per 3GPP TS 45.005
 4. Power on any port must not exceed +20 dBm during switching event.

Table 2. Operating Ranges

Parameter	Symbol	Min	Typ	Max	Units
Temperature range	T _{OP}	-40		+85	°C
V _{DD} Supply Voltage	V _{DD}	2.5	2.70	2.8	V
I _{DD} Power Supply Current (V _{DD} = 2.75 V)	I _{DD}		13	20	µA
TX input power ⁵ (VSWR ≤ 3:1) 824-915 MHz	P _{IN}			+35	dBm
TX input power ⁵ (VSWR ≤ 3:1) 1710-1910 MHz				+33	
RX input power ⁵ (VSWR = 1:1)	P _{IN}			+20	dBm
Control Voltage High	V _{IH}	0.7 x V _{DD}			V
Control Voltage Low	V _{IL}			0.3 x V _{DD}	V

- Note:
5. Assumes RF input period of 4620 µs and duty cycle of 50%.

Table 3. Absolute Maximum Ratings

Symbol	Parameter/Conditions	Min	Max	Units
V _{DD}	Power supply voltage	-0.3	4.0	V
V _I	Voltage on any DC input	-0.3	V _{DD} +0.3	V
T _{ST}	Storage temperature range	-65	+150	°C
T _{OP}	Operating temperature range	-40	+85	°C
P _{IN} (50 Ω)	TX input power (50 Ω) ^{6,7} 824-915 MHz		+38	dBm
	TX input power (50 Ω) ^{6,7} 1710-1910 MHz		+36	
	RX input power (50 Ω) ⁷		+23	
P _{IN} (∞ :1)	TX input power (VSWR = (∞ :1) ^{6,7} 824-915 MHz		+35	dBm
	TX input power (VSWR = (∞ :1) ^{6,7} 1710-1910 MHz		+33	dBm
V _{ESD}	ESD Voltage (HBM, MIL_STD 883 Method 3015.7)		1500	V
	ESD Voltage (MM, JEDEC, JESD22-A114-B)		100	V

- Notes:
6. Assumes RF input period of 4620 µs and duty cycle of 50%.
 7. V_{DD} within operating range specified in Table 2.

Part performance is not guaranteed under these conditions. Exposure to absolute maximum conditions for extended periods of time may adversely affect reliability. Stresses in excess of absolute maximum ratings may cause permanent damage.

Table 4. Pin Descriptions

Pin No.	Pin Name	Description
1	TX1 ⁸	RF I/O – TX1
2	GND	TX Ground
3	TX2 ⁸	RF I/O – TX2
4	RX1 ⁸	RF I/O – RX1
5	RX2 ⁸	RF I/O – RX2
6	RX3 ⁸	RF I/O – RX3
7	RX4 ⁸	RF I/O – RX4
8	GND	RX Ground
9	V3	Switch control input, CMOS logic level
10	V2	Switch control input, CMOS logic level
11	V1	Switch control input, CMOS logic level
12	V _{DD}	Supply
13	GND	DC Ground
14	ANT ⁸	RF Common - Antenna
15	GND	DC Ground
16	GND	DC Ground

Note: 8. Blocking capacitors needed only when non-zero DC voltage present

Figure 4. Pad Configuration (Top View)

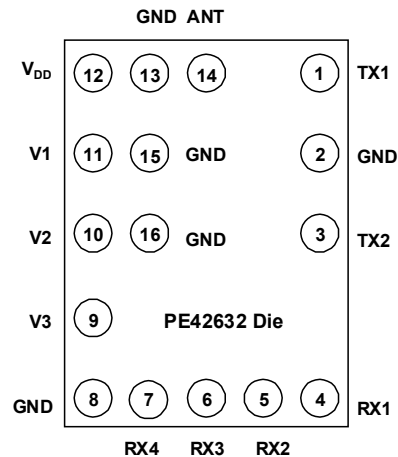

Table 5. Truth Table

Path	V3	V2	V1
ANT - TX1	0	1	1
ANT - TX2	0	0	1
ANT - RX1	1	1	0
ANT - RX2	0	1	0
ANT - RX3	1	0	0
ANT - RX4	0	0	0

Electrostatic Discharge (ESD) Precautions

When handling this UltraCMOS™ device, observe the same precautions that you would use with other ESD-sensitive devices. Although this device contains circuitry to protect it from damage due to ESD, precautions should be taken to avoid exceeding the specified rating.

Latch-Up Avoidance

Unlike conventional CMOS devices, UltraCMOS™ devices are immune to latch-up.

Table 6. Ordering Information

Order Code	Description	Package	Shipping Method
PE42632DTI	PE42632-DIE-D	Bumped Wafer on Film Frame	Wafer (Gross Die / Wafer Quantity)
PE42632DBI	PE42632-DIE-400G	Die in Waffle Pack	400 Dice / Waffle Pack
EK-42632-01	PE42632-DIE-1H	Evaluation Kit	1/ box

Sales Offices

The Americas

Peregrine Semiconductor Corporation

9380 Carroll Park Drive
San Diego, CA 92121
Tel: 858-731-9400
Fax: 858-731-9499

Europe

Peregrine Semiconductor Europe

Bâtiment Maine
13-15 rue des Quatre Vents
F-92380 Garches, France
Tel: +33-1-4741-9173
Fax : +33-1-4741-9173

Space and Defense Products

Americas:

Tel: 858-731-9453

Europe, Asia Pacific:

180 Rue Jean de Guiramand
13852 Aix-En-Provence Cedex 3, France
Tel: +33-4-4239-3361
Fax: +33-4-4239-7227

Peregrine Semiconductor, Asia Pacific (APAC)

Shanghai, 200040, P.R. China
Tel: +86-21-5836-8276
Fax: +86-21-5836-7652

Peregrine Semiconductor, Korea

#B-2607, Kolon Tripolis, 210
Geumgok-dong, Bundang-gu, Seongnam-si
Gyeonggi-do, 463-943 South Korea
Tel: +82-31-728-3939
Fax: +82-31-728-3940

Peregrine Semiconductor K.K., Japan

Teikoku Hotel Tower 10B-6
1-1-1 Uchisaiwai-cho, Chiyoda-ku
Tokyo 100-0011 Japan
Tel: +81-3-3502-5211
Fax: +81-3-3502-5213

For a list of representatives in your area, please refer to our Web site at: www.psemi.com

Data Sheet Identification

Advance Information

The product is in a formative or design stage. The data sheet contains design target specifications for product development. Specifications and features may change in any manner without notice.

Preliminary Specification

The data sheet contains preliminary data. Additional data may be added at a later date. Peregrine reserves the right to change specifications at any time without notice in order to supply the best possible product.

Product Specification

The data sheet contains final data. In the event Peregrine decides to change the specifications, Peregrine will notify customers of the intended changes by issuing a DCN (Document Change Notice).

The information in this data sheet is believed to be reliable. However, Peregrine assumes no liability for the use of this information. Use shall be entirely at the user's own risk.

No patent rights or licenses to any circuits described in this data sheet are implied or granted to any third party.

Peregrine's products are not designed or intended for use in devices or systems intended for surgical implant, or in other applications intended to support or sustain life, or in any application in which the failure of the Peregrine product could create a situation in which personal injury or death might occur. Peregrine assumes no liability for damages, including consequential or incidental damages, arising out of the use of its products in such applications.

The Peregrine name, logo, and UTSi are registered trademarks and UltraCMOS and HaRP are trademarks of Peregrine Semiconductor Corp.