

# Ribbon Cable Connector

## HIF4 Series



### ■ Features

#### 1. Current Capacity

The HIF4 series connector is capable of 3 A current capacity used for wider applications, while the HIF3 series uses 1 A capacity.

#### 2. Full Lock Mechanism

This connector is equipped with a Hirose original locking mechanism, and guarantees excellent reliability for vibration and shock.

#### 3. One-touch Insertion and Extraction Mechanism

This connector is equipped with levers for automatic insertion and extraction, as soon as lock is reset. Insertion and extraction tools are not required.

#### 4. Applicable Cable

The applicable cable is UL2651 AWG#24 flat cable (7 cores./0.203mm, jacket dia :1.0 to 1.2mm).

### ■ Applications

Computers, terminal equipment, various kinds of electronic equipment, and office automation machines

### ■ Product Specifications

Rating	Current rating : 3A Voltage rating : 300V AC	Operating Temperature Range : -55 to +85°C (Note 1) Operating Moisture Range : 40 to 80%	Storage Temperature Range : -10 to +60°C (Note 2) Storage Humidity Range : 40 to 70% (Note 2)
--------	---	---	--

Item	Specification	Condition
1. Insulation Resistance	1000M ohms min	500V DC
2. Withstanding voltage	No flashover or insulation breakdown.	1000V AC/1 minute
3. Contact Resistance	15m ohms max	0.1A
4. Vibration	No electrical discontinuity of 1 $\mu$ s or more	Frequency: 10 to 55 Hz, single amplitude of 0.75 mm, 2 hours in each of the 3 directions.
5. Humidity (Steady state)	Insulation resistance: 1000M ohms min.	96 hours at temperature of 40°C and humidity of 90% to 95%
6. Temperature Cycle	No damage, cracks, or parts looseness.	(-65°C: 30 minutes → 15 to 35°C: 5 minutes max. 125°C: 30 minutes → 15 to 35°C: 5 minutes max.) 5 cycles
7. Operating Life	Contact resistance: 15m ohms max.	500 cycles
8. Resistance to Soldering heat	No deformation of components affecting performance.	Flow: 260°C for 10 seconds Manual soldering: 300°C for 3 seconds

Note 1: Includes temperature rise caused by current flow.

Note 2: The term "storage" refers to products stored for long period of time prior to mounting and use. Operating Temperature Range and Humidity range covers non conducting condition of installed connectors in storage, shipment or during transportation.

### ■ Material

Part	Material	Finish	Remarks
Insulator	PBT	Black	UL94V-0
Contact	Socket	gold plated	—
	Pin header	gold plated	

## ■ Ordering Information

### ● Pin Header

HIF4 - \* P - 3.18 DS  
①                    ②   ③                    ④                    ⑤

① Series Name	: HIF4
② Number of Contacts	: 16, 20, 26, 34, 40
③ P : Pin header	
④ Contact Pitch	: 3.18mm
⑤ Contact Type	
	DS : Right angle type
	SA : Straight dip type
	W : Wrapping type

### ● Socket

HIF4 - \* D - 3.18 R  
①                    ②   ③                    ④                    ⑤

① Series Name	: HIF4
② Number of Contacts	: 16, 20, 26, 34, 40
③ Contact alignment	: D : Double
④ Contact Pitch	: 3.18mm
⑤ Connection type	: Ribbon cable

## Socket

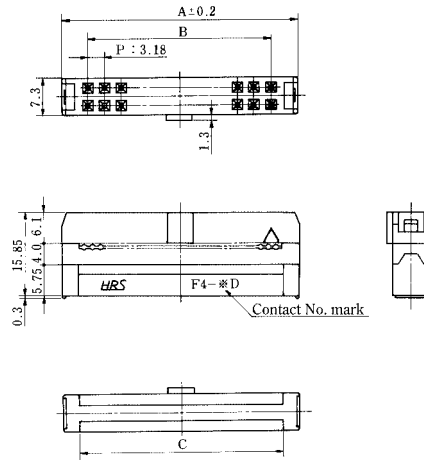

Unit:mm

Part Number	CL No.	Number of Contacts	A	B	C
HIF4-16D-3.18R	563-0025-5	16	31.98	22.26	26.28
HIF4-20D-3.18R	563-0010-8	20	38.34	28.62	32.64
HIF4-26D-3.18R	563-0011-0	26	47.88	38.16	42.18
HIF4-34D-3.18R	563-0012-3	34	60.6	50.88	54.9
HIF4-40D-3.18R	563-0029-6	40	70.14	60.42	64.44

## Pin Header Right Angle Type

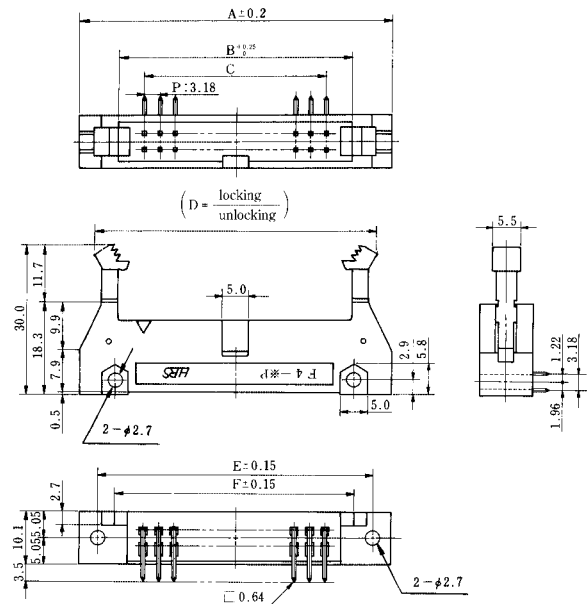

Unit:mm

Part Number	CL No.	Number of Contacts	A	B	C	D	E	F
HIF4-16P-3.18DS	563-0026-8	16	46.68	32.18	22.26	$\frac{42.82}{63.28}$	39.98	33.58
HIF4-20P-3.18DS	563-0001-7	20	53.04	38.54	28.62	$\frac{49.18}{69.64}$	46.34	39.94
HIF4-26P-3.18DS	563-0002-0	26	62.58	48.08	38.16	$\frac{58.72}{79.18}$	55.88	49.48
HIF4-34P-3.18DS	563-0003-2	34	75.3	60.8	50.88	$\frac{71.44}{91.90}$	68.6	62.2
HIF4-40P-3.18DS	563-0030-5	40	84.84	70.34	60.42	$\frac{80.89}{101.44}$	78.14	71.74

## ■Pin Header Straight Through hole Type

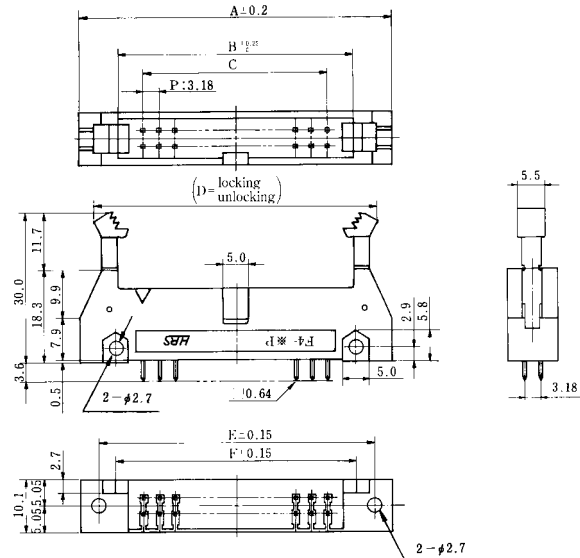

Unit:mm

Part Number	CL No.	Number of Contacts	A	B	C	D	E	F
HIF4-16P-3.18DSA	563-0027-0	16	46.68	32.18	22.26	<u>42.82</u> 63.28	39.98	33.58
HIF4-20P-3.18DSA	563-0004-5	20	53.04	38.54	28.62	<u>49.18</u> 69.64	46.34	39.94
HIF4-26P-3.18DSA	563-0005-8	26	62.58	48.08	38.16	<u>58.72</u> 79.18	55.88	49.48
HIF4-34P-3.18DSA	563-0006-0	34	75.3	60.8	50.88	<u>71.44</u> 91.90	68.6	62.2
HIF4-40P-3.18DSA	563-0031-8	40	84.84	70.34	60.42	<u>80.98</u> 101.44	78.14	71.74

## ■Pin Header Wrapping Type

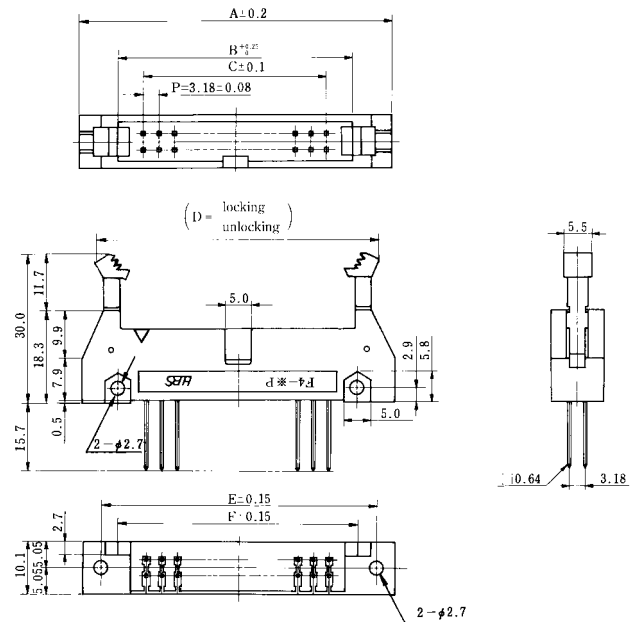

Unit:mm

Part Number	CL No.	Number of Contacts	A	B	C	D	E	F
HIF4-16P-3.18W	563-0028-3	16	46.68	32.18	22.26	<u>42.82</u> 63.28	39.98	33.58
HIF4-20P-3.18W	563-0007-3	20	53.04	38.54	28.62	<u>49.18</u> 69.64	46.34	39.94
HIF4-26P-3.18W	563-0008-6	26	62.58	48.04	38.16	<u>58.72</u> 79.18	55.88	49.48
HIF4-34P-3.18W	563-0009-9	34	75.3	60.8	50.88	<u>71.44</u> 91.90	68.6	62.2
HIF4-40P-3.18W	563-0032-0	40	84.84	70.34	60.42	<u>80.98</u> 101.44	78.14	71.74

## ◆PCB mounting pattern

### ●Pin Header Right Angle Type

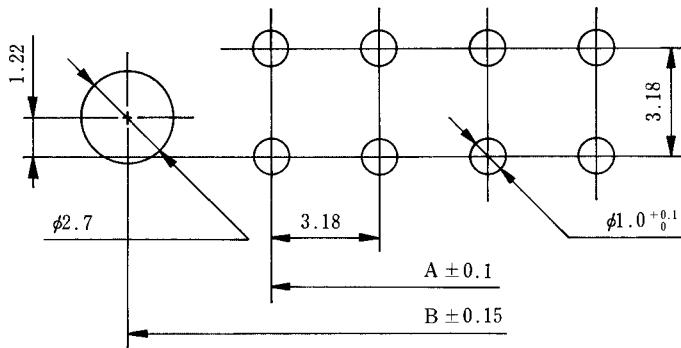

Number of Contacts	A	B
16	22.26	33.58
20	28.62	39.94
26	38.16	49.48
34	50.88	62.20
40	60.42	71.74

### ●Pin Header Straight Through hole Type or Pin Header Wrapping Type

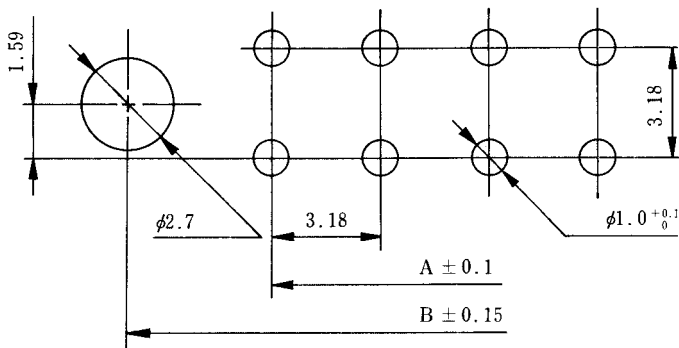

Number of Contacts	A	B
16	22.26	39.98
20	28.62	46.34
26	38.16	55.88
34	50.88	68.60
40	60.42	78.14

### ●Type Shape

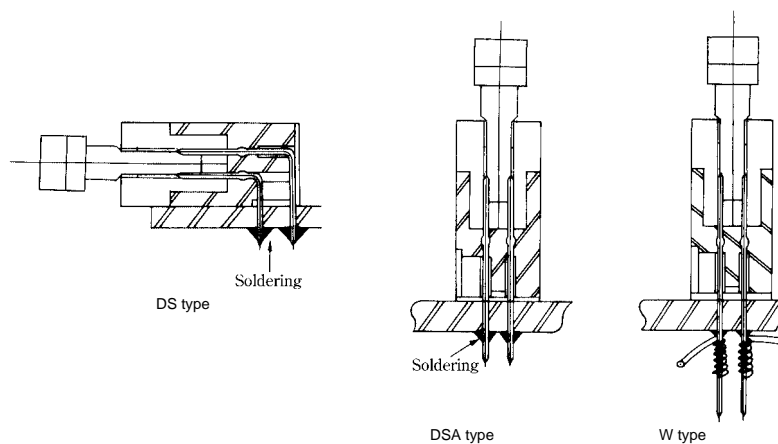

# ◆HIF4 Basic Connection Method

As shown below in Figure 1, contact positions are indicated by marks (○●◆◇).

Fig.1

The connected contact is indicated with a symbol next to the individual type name. However, the contact symbol connected to the cable mark is indicated at the mark \*.

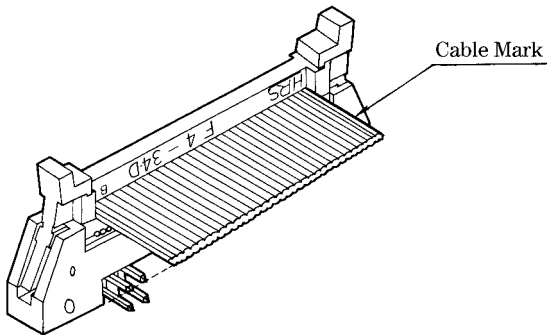

Type AO

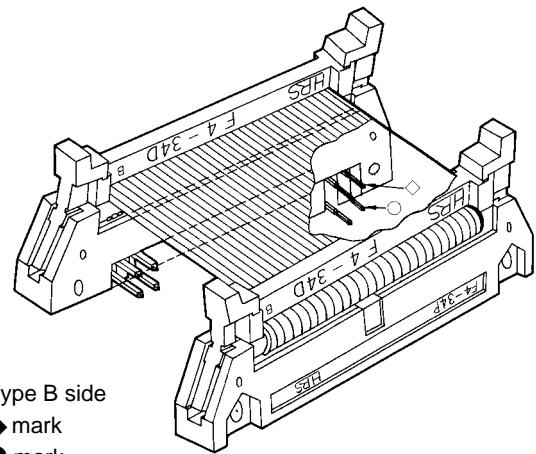

Type AB

Type A side    Type B side  
 \* ○ mark and    ◆ mark  
 ◇ mark and    ● mark

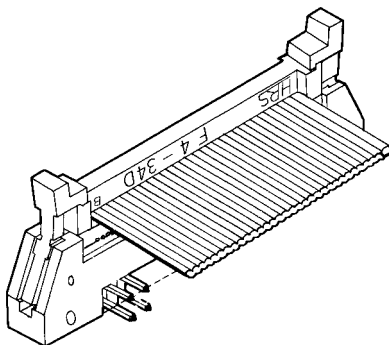

Type BO

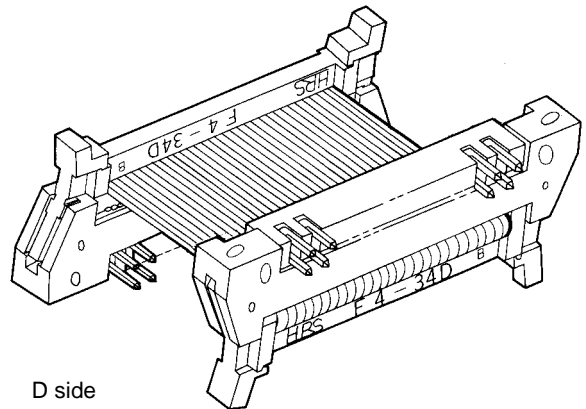

Type AD

A side    D side  
 \* ○ mark and    ◆ mark  
 ◇ mark and    ● mark

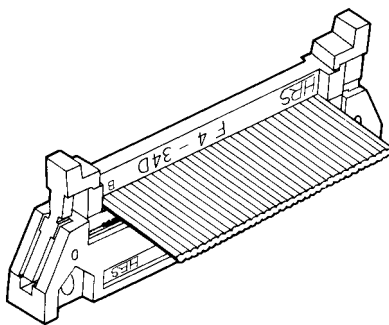

Type CO

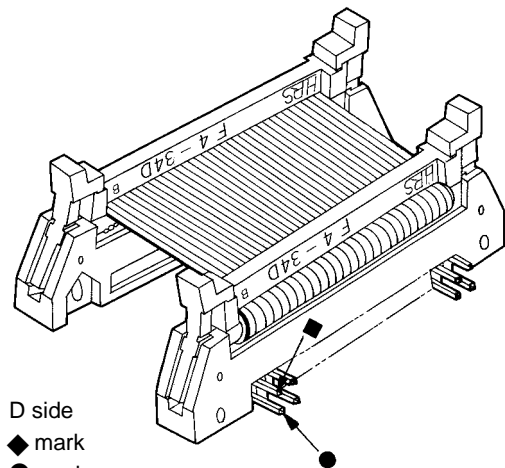

Type CD

C side    D side  
 \* ○ mark and    ◆ mark  
 ◇ mark and    ● mark

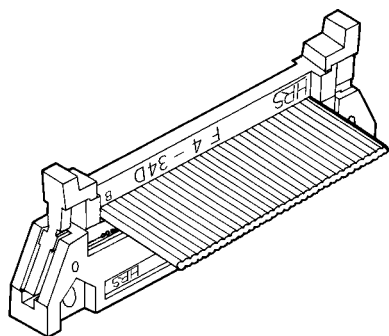

Type DO

Contact positions are designated with marks as shown below.

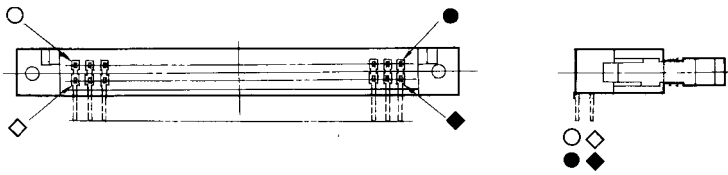

According to the illustration on the left, the illustration 1 indicates these positions on the right.

Note 1: Cable length tolerance  
 500 +10, 0 max. (mm)  
 500 +3%, 0% min.

Note 2. When a twist cable or a slit (like a roller screen) cable is used, the cable pitch will change according to cable manufacturers. If connection failure has occurred, consult HRS Sales Department.

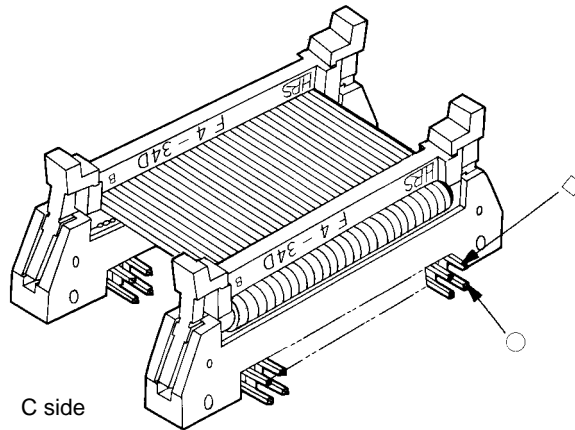

**Type AC**

A side                      C side  
 \* ○ mark and ○ mark  
   ◇ mark and ◇ mark

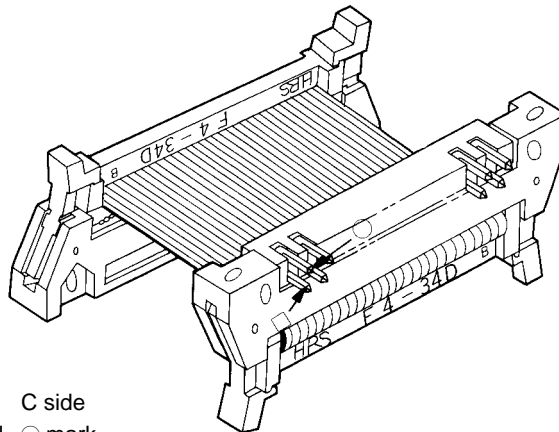

**Type CC**

C side                      C side  
 \* ○ mark and ○ mark  
   ◇ mark and ◇ mark

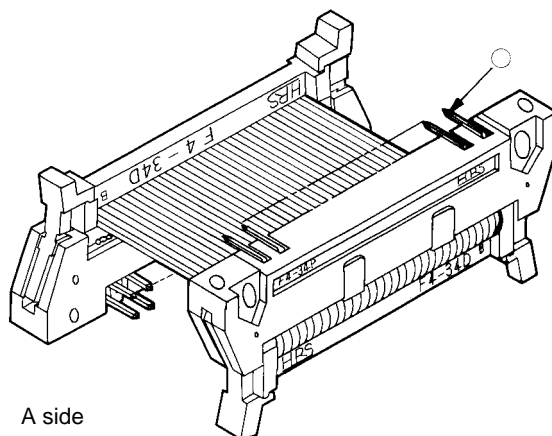

**Type AA**

A side                      A side  
 \* ○ mark and ○ mark  
   ◇ mark and ◇ mark