

**3V Quad-Band GSM850/900 DCS/PCS Transmit Module**

**Functional Block Diagram**

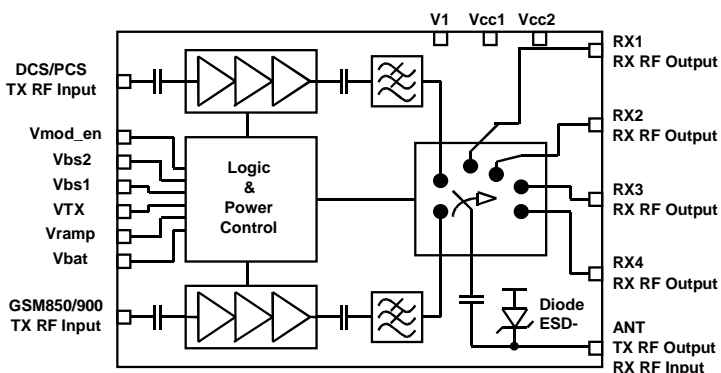

**Product Description**

The advanced quad-band Transmit Module designed for mobile handset applications provides full RF transmit functionality in a size of only 36 mm<sup>2</sup>. The GSM850/900 and DCS/PCS power amplifier blocks including power control are combined with the low insertion loss quad-band pHEMT switch, Tx harmonics filtering, integrated switch decoder, four receive ports, and full ESD protection. This architecture eliminates the need for any PA-to-switch design effort for phone designers. All four Rx ports are frequency independent and allow flexible routing to the transceiver. Fabricated in high-reliability InGaP HBT / pHEMT technology, the module supports GPRS class 12 operation and provides 50 Ohms input and output impedances at all RF input and output ports. The module control inputs are CMOS compatible and *has no need for an external reference voltage*. With its excellent efficiency performance in all 4 bands, the power amplifier and switch module contributes to the overall talk-time targets of next generation mobile handset designs.

**Features**

- Ultra Compact Size – 6.0x6.0x1.1mm<sup>3</sup>.
- High System Efficiency – GSM850 40%, GSM900 45% , DCS/PCS 38%
- Integrated Power and SP6T Control
- Integrated SP6T pHEMT Switch
- Free choice of Rx ports for band selection
- Integrated Low Pass Tx Harmonics Filter
- Positive Supply Voltage 3.0 to 4.5 V.
- 50 Ω Input and Output Impedances.
- GPRS Class 12 Compatible.
- CMOS Compatible Module Control Inputs.
- High-Reliability InGaP HBT Technology
- Ruggedness 30:1.

**Applications**

- GSM GPRS Handsets and Modems
- Dual-, Tri-, Quad-band Class 12 Compatible

**Package Style**

