



PART NO.: 27-21SYGC/S530-E1/TR8

Device Number : DSE-271-004 REV. 1.0

Chip LEDs with Right Angle Lens

ECN : _____ Page: 1/8

Features :

- Package in 8mm tape on 7" diameter reel.
- Compatible with automatic placement equipment.
- Compatible with infrared and vapor phase reflow solder process.
- Mono-color type.

Descriptions :

- The 27-21 SMD Taping is much smaller than leaded components, thus enable smaller board size, higher packing density, reduced storage space and finally smaller equipment to be obtained.
- Besides, lightweight makes them ideal for miniature applications, etc.

Applications :

- Automotive: backlighting in dashboard and switch.
- Telecommunication: indicator and backlighting in telephone and fax.
- Flat backlight for LCD, switch and symbol.
- General use.

Package Dimensions :

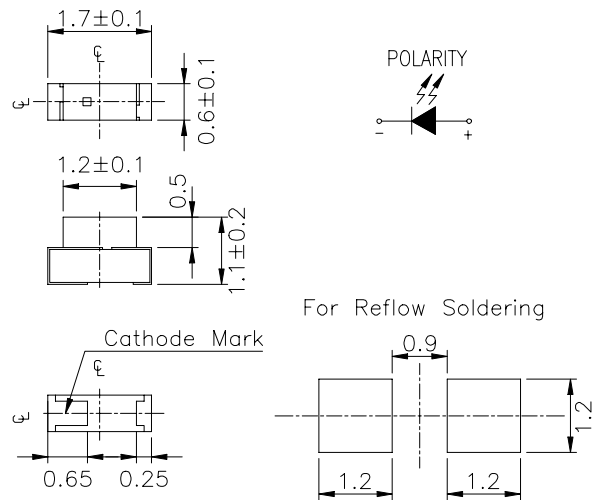

Notes :

Tolerances Unless Dimension $\pm 0.1\text{mm}$
 Angle $\pm 0.5^\circ$
 Unit = mm

PART NO	Chip		Lens Color
	Material	Emitted Color	
27-21 SYGC/S530-E1/TR8	AlGaInP	Super Yellow Green	Water Clear

OFFICE: NO. 25, Lane 76, Sec.3, Chung Yang Rd., Tucheng 236, Taipei, Taiwan, R.O.C.

TEL.: 886-2-2267-2000, 2267-9936

FAX: 886-2-2267-6244, 2267-6189, 2267-6306

http://www.everlight.com



EVERLIGHT ELECTRONICS CO., LTD.

PART NO.: 27-21 SYGC/S530-E1/TR8

Device Number : DSE-271-004 REV. 1.0

Chip LEDs with Right Angle Lens

ECN : Page: 2/8

■ Package Dimensions :

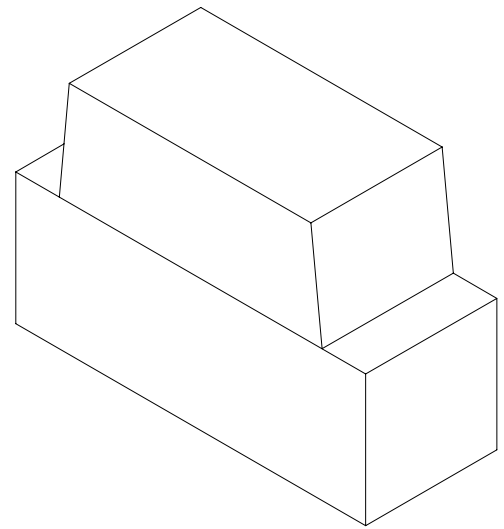
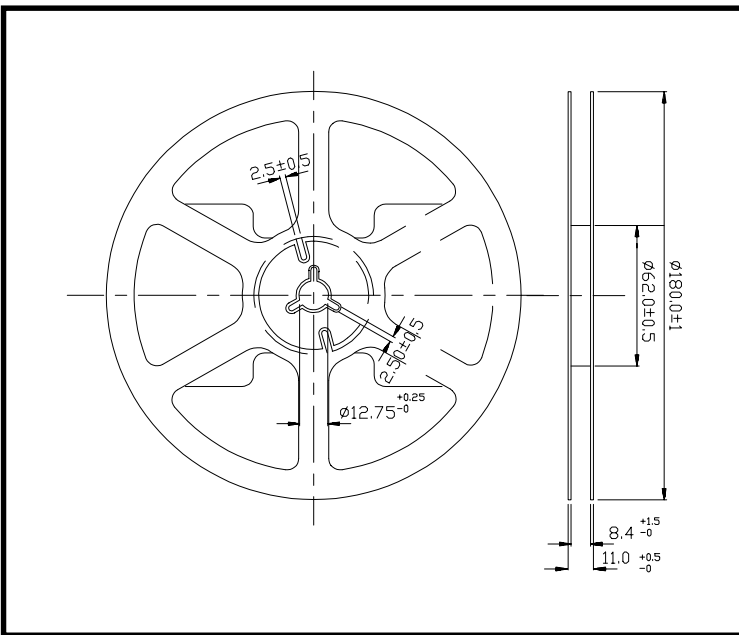

■ Loaded quantity per reel 3000 PCS/reel :

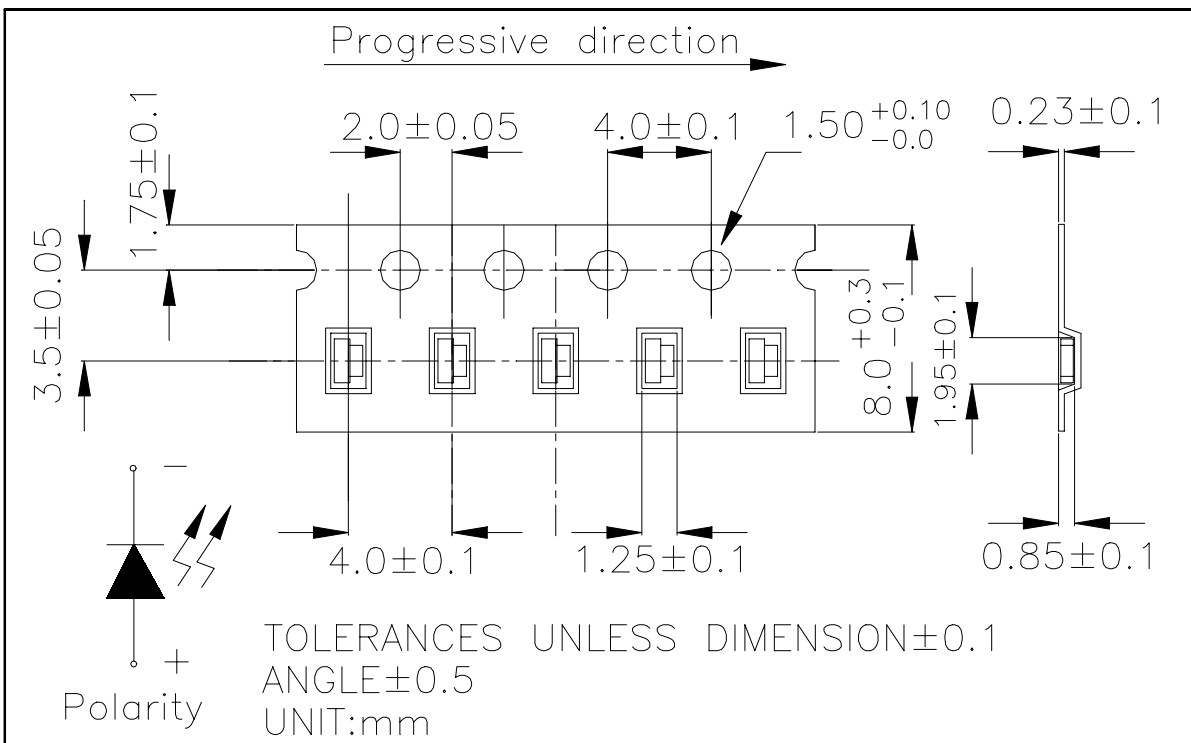



PART NO.: 27-21 SYGC/S530-E1/TR8

Device Number : DSE-271-004 REV. 1.0

Chip LEDs with Right Angle Lens

ECN : Page: 3/8

■ Absolute Maximum Ratings at Ta = 25°C

Parameter	Symbol	Rating	Unit
Reverse Voltage	V _R	5	V
Forward Current	I _F	25	mA
Operating Temperature	T _{opr}	-40 ~ +85	°C
Storage Temperature	T _{stg}	-40 ~ +90	°C
Soldering Temperature	T _{sol}	260 (for 5 second)	°C
Electrostatic Discharge	ESD	2000	V
Power Dissipation	P _d	60	mW
Peak Forward Current(Duty 1/10 @ 1KHZ)	I _{F(Peak)}	160	mA

■ Electronic Optical Characteristics :

Parameter	Symbol	Min.	Typ.	Max.	Unit	Condition
Luminous Intensity	I _V	-----	1	-----	mcd	I _F =2mA
		10	15	-----	mcd	I _F =20mA
Viewing Angle	2θ 1/2	-----	130	-----	deg	I _F =20mA
Peak Wavelength	λ _p	-----	575	-----	nm	I _F =20mA
Dominant Wavelength	λ _d	-----	573	-----	nm	I _F =20mA
Spectrum Radiation Bandwidth	Δλ	-----	20	-----	nm	I _F =20mA
Forward Voltage	V _F	-----	2.0	2.4	V	I _F =20mA
Reverse Current	I _R	-----	-----	10	μA	V _R =5V



PART NO.: 27-21 SYGC/S530-E1/TR8

Device Number : DSE-271-004 REV. 1.0

Chip LEDs with Right Angle Lens

ECN : Page: 4/8

■ Reliability Test Items And Conditions

NO	Item	Test Conditions	Test Hours/Cycle	Sample Size	Ac/Re
1	Solder Heat	TEMP. : 260°C ± 5 °C	5 SEC.	76 PCS	0/1
2	Temperature Cycle	H : +85°C 30min. ∫ 5 min. L : -55°C 30min.	50 CYCLES	76 PCS	0/1
3	Thermal Shock	H : +100°C 5min. ∫ 10 sec. L : -10°C 5min.	50 CYCLES	76 PCS	0/1
4	High Temperature Storage	TEMP. : 100°C	1000 HR.	76 PCS	0/1
5	Low Temperature Storage	TEMP. : -55°C	1000 HR.	76 PCS	0/1
6	DC Operating Life	IF= 20 mA	1000 HR.	76 PCS	0/1
7	High Temperature / High Humidity	85°C/RH85%	1000 HR.	76 PCS	0/1



PART NO.: 27-21 SYGC/S530-E1/TR8

Device Number : DSE-271-004 REV. 1.0

Chip LEDs with Right Angle Lens

ECN : Page: 5/8

Typical Electro-Optical Characteristic Curves

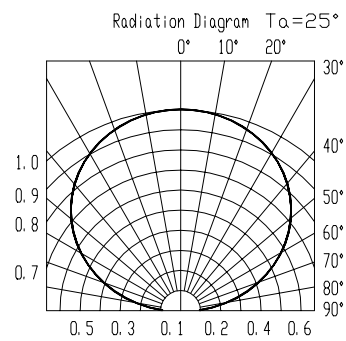
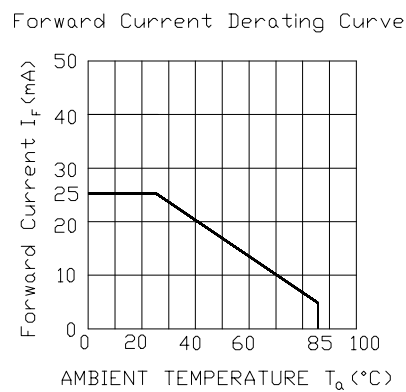
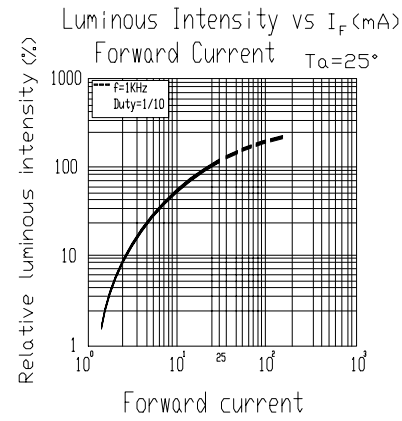
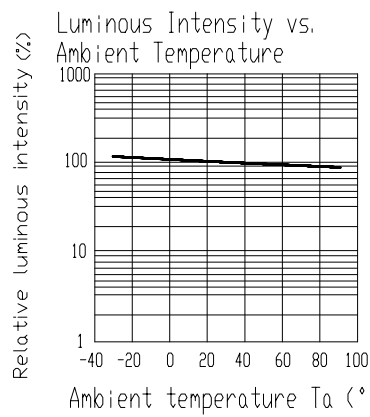
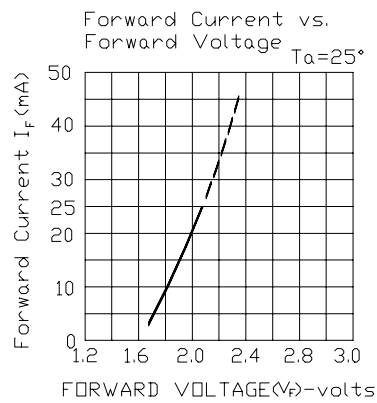
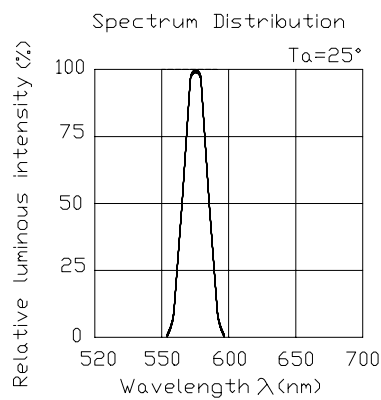



PRAT NO: 27-21 SYGC/S530-E1/TR8

Device Number : DSE-271-004 REV. 1.0

Chip LEDs with Right Angle Lens

ECN : _____ Page: 6/8

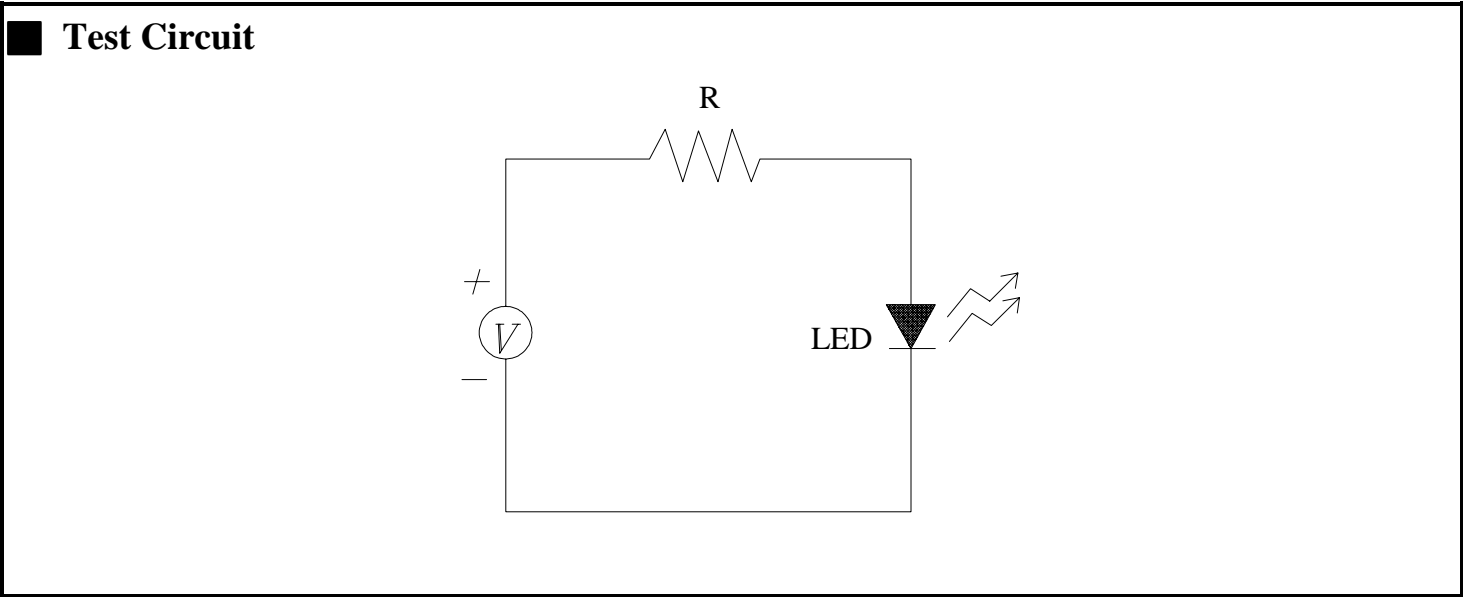

- **Precautions For Use**
1. Over-current-proof
Customer must apply resistors for protection , otherwise slight voltage shift will cause big current change (Burn out will happen).

 2. Storage time
 - 2.1 The operation of temperature and RH are : $5^{\circ}\text{C} \sim 35^{\circ}\text{C}$, RH60%.
 - 2.2 Once the package is opened, the products should be used within a week. Otherwise, they should be kept in a damp proof box with desiccating agent. Considering the tape life , we suggest our customers to use our products within a year(from production date).
 - 2.3 If opened more than one week in an atmosphere $5^{\circ}\text{C} \sim 35^{\circ}\text{C}$, RH60% , they should be treated at $60^{\circ}\text{C} \pm 5^{\circ}\text{C}$ for 15hrs.
 - 2.4 When you discover that the desiccant in the package has a pink color (normal = blue) , you should treat them in the same conditions as 2.3.

■ **Soldering heat reliability (DIP)**

Please refer to the following figure :

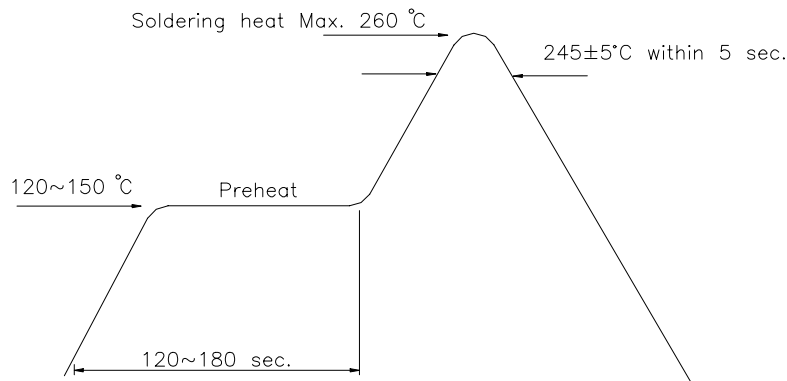

■ **Soldering Iron**

Basic spec is ≤ 5 sec. when 260°C . If temperature is higher, time should be shorter ($+10^{\circ}\text{C} \rightarrow -1\text{sec.}$). Power dissipation of iron should be smaller than 15 W , and temperature should be controllable. Surface temperature of the device should be under 230°C .

■ **Rework**

1. Customer must finish rework within 5 sec. under 260°C .
2. Copper foil can not be touched by the head of iron.
3. Twin-head type is preferred.

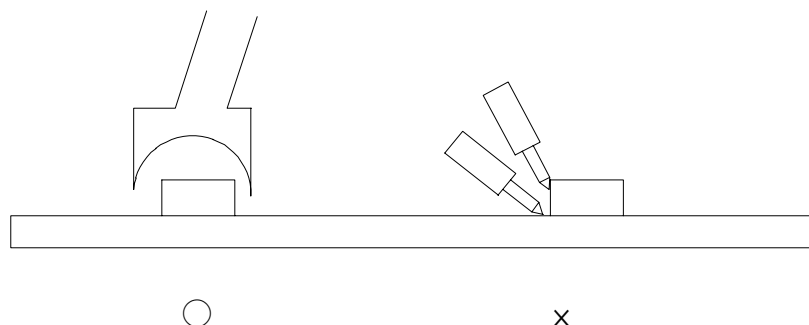



PRAT NO: 27-21 SYGC/S530-E1/TR8

Device Number : DSE-271-004 REV: 1.0

Chip LEDs with Right Angle Lens

ECN : Page: 8/8

■ Reflow Temp./Time :

