eKM8022

**USB & PS/2
Mouse Controller**

**Product
Specification**

DOC. VERSION 1.0

ELAN MICROELECTRONICS CORP.

April 2004



Trademark Acknowledgments:

IBM is a registered trademark and PS/2 is a trademark of IBM.

Windows is a trademark of Microsoft Corporation.

ELAN and ELAN logo  are trademarks of ELAN Microelectronics Corporation.

Copyright © 2005 by ELAN Microelectronics Corporation

All Rights Reserved

Printed in Taiwan

The contents of this specification are subject to change without further notice. ELAN Microelectronics assumes no responsibility concerning the accuracy, adequacy, or completeness of this specification. ELAN Microelectronics makes no commitment to update, or to keep current the information and material contained in this specification. Such information and material may change to conform to each confirmed order.

In no event shall ELAN Microelectronics be made responsible for any claims attributed to errors, omissions, or other inaccuracies in the information or material contained in this specification. ELAN Microelectronics shall not be liable for direct, indirect, special incidental, or consequential damages arising from the use of such information or material.

The software (if any) described in this specification is furnished under a license or nondisclosure agreement, and may be used or copied only in accordance with the terms of such agreement.

ELAN Microelectronics products are not intended for use in life support appliances, devices, or systems. Use of ELAN Microelectronics product in such applications is not supported and is prohibited.

NO PART OF THIS SPECIFICATION MAY BE REPRODUCED OR TRANSMITTED IN ANY FORM OR BY ANY MEANS WITHOUT THE EXPRESSED WRITTEN PERMISSION OF ELAN MICROELECTRONICS.



ELAN MICROELECTRONICS CORPORATION

Headquarters:

No. 12, Innovation Road 1
Hsinchu Science Park
Hsinchu, Taiwan 30077
Tel: +886 3 563-9977
Fax: +886 3 563-9966
<http://www.emc.com.tw>

Hong Kong:

Elan (HK) Microelectronics Corporation, Ltd.
Rm. 1005B, 10/F Empire Centre
68 Mody Road, Tsimshatsui
Kowloon, HONG KONG
Tel: +852 2723-3376
Fax: +852 2723-7780
elanhk@emc.com.hk

USA:

Elan Information Technology Group
1821 Saratoga Ave., Suite 250
Saratoga, CA 95070
USA
Tel: +1 408 366-8223
Fax: +1 408 366-8220

Europe:

Elan Microelectronics Corp. (Europe)
Siewerdtstrasse 105
8050 Zurich, SWITZERLAND
Tel: +41 43 299-4060
Fax: +41 43 299-4079
<http://www.elan-europe.com>

Shenzhen:

Elan Microelectronics Shenzhen, Ltd.
SSMEC Bldg., 3F, Gaoxin S. Ave.
Shenzhen Hi-Tech Industrial Park
Shenzhen, Guangdong, CHINA
Tel: +86 755 2601-0565
Fax: +86 755 2601-0500

Shanghai:

Elan Microelectronics Shanghai Corporation, Ltd.
23/Bldg. #115 Lane 572, Bibo Road
Zhangjiang Hi-Tech Park
Shanghai, CHINA
Tel: +86 021 5080-3866
Fax: +86 021 5080-4600



Contents

1	General Description	1
2	Features	1
3	Pin assignment	2
3.1	eKM8022A (18-Pin) for 3D3K Z/2.....	2
3.2	eKM8022A (18-Pin) Bounding PAD.....	2
3.3	eKM8022B (20-Pin) for 3D3K Z/4	3
3.4	eKM8022B (20-Pin) Bounding PAD.....	3
4	Function Description	4
4.1	Quadrature Signal Timing Diagram	4
4.1.1	X、Y、Z Axis Counting	4
4.1.2	Quadrature Output Crossed Width Limit	5
4.2	PS/2 Function Description	5
4.2.1	PS/2 Mouse Commands Description	5
4.2.2	Microsoft PS/2 Scrolling Mouse	5
4.2.3	USB function Description	7
5	Absolute Maximum Rating	8
6	Electrical Characteristic	8
7	Package Diagram	9
7.1	PDIP-18L 300MIL PACKAGE OUTLINE DIMENSION(Unit:mm)	9
7.2	PDIP-20L 300MIL PACKAGE OUTLINE DIMENSION(Unit:mm)	9
7.3	SOP-18L 300MIL PACKAGE OUTLINE DIMENSION(Unit:mm)	10
7.4	SOP-20L 300MIL PACKAGE OUTLINE DIMENSION(Unit:mm)	10
8	Pad List Information	11
8.1	eKM8022A Pad Configuration	11
8.2	eKM8022A Pad Name & Coordinate Table	11
8.3	eKM8022B Pad Configuration	12
8.4	eKM8022B Pad Name & Coordinate Table	12
9	Application Circuit	13
9.1	NOTICE DIAGRAM	13
9.2	COMPONENTS IN DETAIL.....	13
9.3	eKM8022A_Mechanical Z/2 Application For Ball Type.....	14
9.4	eKM8022B_Photo_Z/4 Application For Ball Type.....	14
9.5	eKM8022A_Mechanical Z/2 Application For OM02.....	15
9.6	eKM8022B_Photo Z/4 Application For OM02	15



Specification Revision History

Doc. Version	Revision Description	Date
1.0	Preliminary version	2004/04/16



1 General Description

The eKM8022 is a Mouse Controller designed to control both USB & PS/2 Mouse device for XY Quadrature mode. This Mouse Controller can auto detect USB or PS/2 mode, and supports X, Y, Z three axes with 400/800 DPI(simulated by firmware), and L, R, M three buttons under both USB and PS2 mode.

2 Features

- Universal Serial Bus Specification, version 1.1
- USB HID Specification, version 1.11
- Auto-detecting PS/2 port or USB port.
- Compatible with Microsoft 3D PS/2 mouse.
- Support 3D (X,Y,Z) 3 Key (L,R,M) input.
- Support Z/2 and Z/4 two Z-axis input type.
- Support Agilent HDNS2000、ADNS2051、OM01、OM02、PixArt
- PAN101BOI/BSI Optical Mouse Sensor.
- 800DPI simulated by firmware.
- Applications :
 - 3D, 3 Buttons USB and PS/2 Combo Mouse
- Package :
 - 18 Pin PDIP (300MIL) eKM8022AP 3D 3K Z/2
 - 18 Pin SOP (300MIL) eKM8022AM 3D 3K Z/2
 - 20 Pin PDIP (300MIL) eKM8022BP 3D 3K Z/4
 - 20 Pin SOP (300MIL) eKM8022BM 3D 3K Z/4

3 Pin assignment

3.1 eKM8022A (18-Pin) for 3D3K Z/2

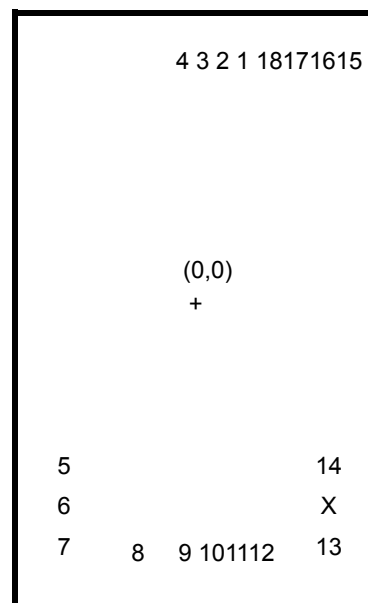
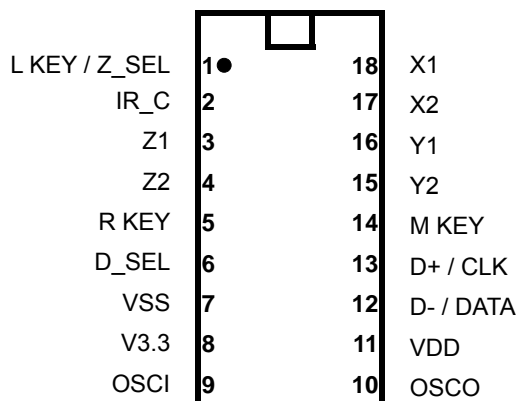

3.2 eKM8022A (18-Pin) Bounding PAD

Symbol	I/O	PIN	Function
L	I	1	Left Key Input
Z_SEL	I	1	Z/2 / Z/4 Selection Pin , FLOATING for Z/2 ; PULL HIGH 5.1K TO 3.3V for Z/4
IR_C	O	2	IR(Sensor power) Control Pin 1
Z1	I	3	Z axis Input 1
Z2	I	4	Z axis Input 2
R	I	5	Right Key Input
D_SEL	I	6	400/800DPI Select Pin , Floating for 400DPI , GND for 800DPI)
V _{SS}	-	7	GND
V _{3.3V}	O	8	3.3V DC voltage output from internal regulator. This pin has to be tied to a 4.7 μ F capacitor.
OSCI	I	9	6MHz ceramic resonator input.
OSCO	I/O	10	Return path for 6-MHz ceramic resonator.
V _{DD}	-	11	5 V Power Input
D- / DATA	I/O	12	USB D- or PS/2 Data I/O
D+ / CLK	I/O	13	USB D+ or PS/2 CLK I/O
M	I	14	Middle Key Input
Y2	I	15	Y axis Input 2
Y1	I	16	Y axis Input 1
X2	I	17	X axis Input 2
X1	I	18	X axis Input 1

3.3 eKM8022B (20-Pin) for 3D3K Z/4

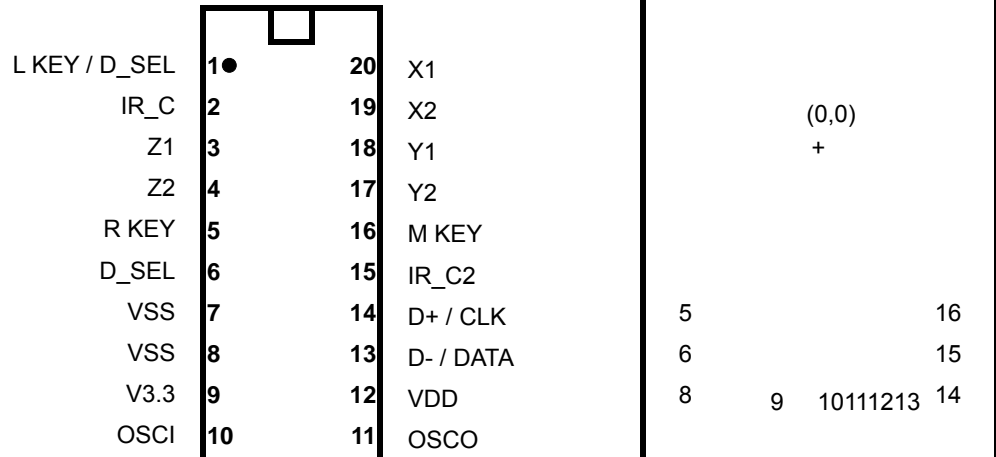

3.4 eKM8022B (20-Pin) Bounding PAD

Symbol	I/O	PIN	Function
L	I	1	Left Key Input
Z_SEL	I	1	Z/2 / Z/4 Selection Pin , FLOATING for Z/2 ; PULL HIGH 5.1K TO 3.3V for Z/4
IR_C	O	2	IR(Sensor power) Control Pin 1
Z1	I	3	Z axis Input 1
Z2	I	4	Z axis Input 2
R	I	5	Right Key Input
D_SEL	I	6	400/800DPI Select Pin , Floating for 400DPI , GND for 800DPI)
VSS	-	7,8	GND
V3.3V	O	9	3.3V DC voltage output from internal regulator. This pin has to be tied to a 4.7 μ F capacitor.
OSCI	I	10	6MHz ceramic resonator input.
OSCO	I/O	11	Return path for 6-MHz ceramic resonator.
VDD	-	12	5 V Power Input
D- / DATA	I/O	13	USB D- or PS/2 Data I/O
D+ / CLK	I/O	14	USB D+ or PS/2 CLK I/O
IR_C2	O	15	IR Control Pin 2 (use for Photo Z/4 Application Power Down)
M	I	16	Middle Key Input
Y2	I	17	Y axis Input 2
Y1	I	18	Y axis Input 1
X2	I	19	X axis Input 2
X1	I	20	X axis Input 1

4 Function Description

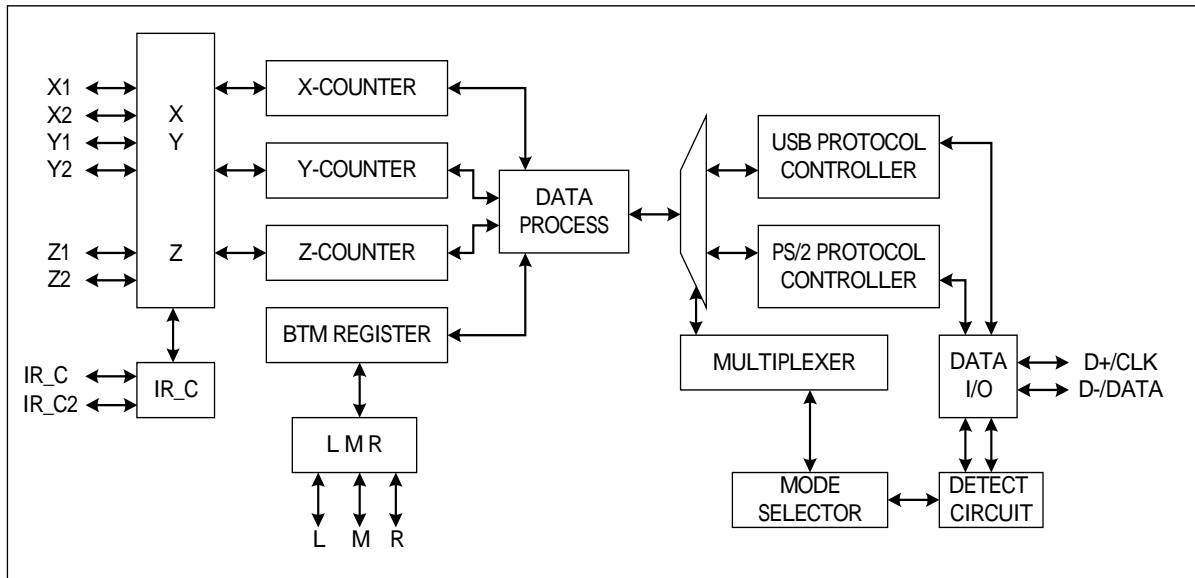
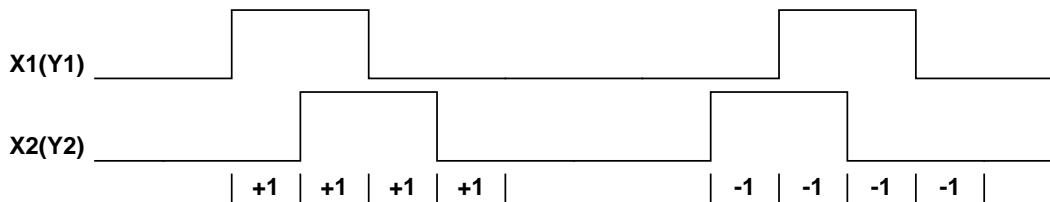

Fig-1 : Function block

4.1 Quadrature Signal Timing Diagram

4.1.1 X, Y, Z Axis Counting

XY AXIS COUNTING



Z/2 COUNTING

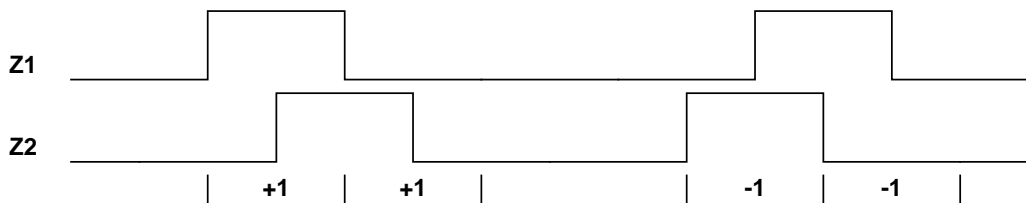

Z/4 COUNTING

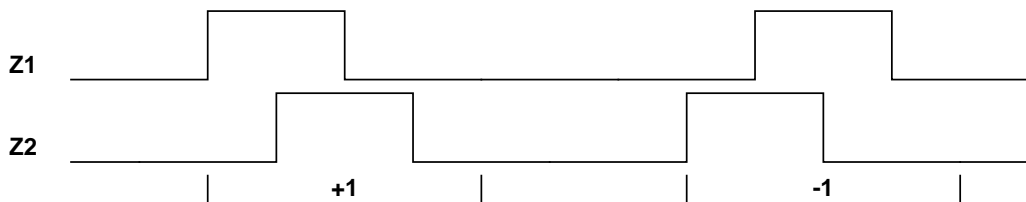

4.1.2 Quadrature Output Crossed Width Limit

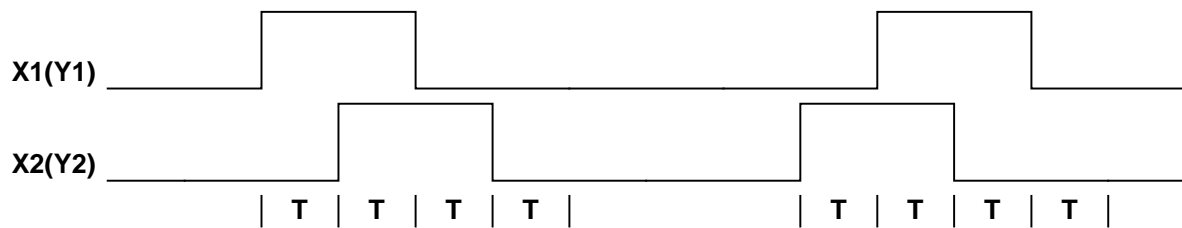

NOTE

For X(Y) Axis , $T > 40\mu s$

For Z Axis , $T > 1ms$

4.2 PS/2 Function Description

4.2.1 PS/2 Mouse Commands Description

Hex Code	Command	eKM8022 echo code
FF	Reset	FA,AA,00
FE	Resend	XX,(XX,XX)
F6	Set Default	FA
F5	Disable	FA
F4	Enable	FA
F3,XX	Set Sampling Rate	FA,FA
F2	Read Device Type	FA,00
F0	Set Remote Mode	FA
EE	Set Wrap Mode	FA
EC	Reset Wrap Mode	FA
EB	Read Data	FA,XX,XX,XX
EA	Set Stream Mode	FA
E9	Status Request	FA,XX,XX,XX
E8	Set Resolution	FA,FA
E7	Set Autospeed	FA
E6	Reset Autospeed	FA

4.2.2 Microsoft PS/2 Scrolling Mouse

4.2.2.1 Entering procedure: Except in WRAP mode, while eKM8022 received the following consecutive command.

- A F3 C8 ---- set sampling rate 200/sec
- B F3 64 ---- set sampling rate 100/sec
- C F3 50 ---- set sampling rate 80/sec



4.2.2.2 Operating

- A All of the commands in legacy mode still be valid.
- B The ID code of read device type command (F2) will changed from "00" to be "03".
- C Data report will be four bytes format:

Byte	Bit	Description
1	0	Left button status; 1 = pressed
	1	Right button status; 1 = pressed
	2	Middle button status; 1 = pressed
	3	Reserve
	4	X data sign; 1 = negative
	5	Y data sign; 1 = negative
	6	X data overflow; 1 = overflow
	7	Y data overflow; 1 = overflow
2	0-7	X data (D0-D7)
3	0-7	Y data (D0-D7)
4	0-7	Z data (D0-D7)

4.2.2.3 Exiting Microsoft Scrolling Mode

There are two ways to exit:

- A Power off.
- B Reset command (FF).

Z-axis Input Function : The Z0-Z7 limit value is ± 7

Z-axis counter accumulates the Z1, Z2 phase changed by movement. This mode includes noise immunity.

Z/2 : 2 dot per count. The wheel should stay at Z1=0, Z2=0 or Z1=1, Z2=1 Phase

Z/4 : 4 dots per count. the wheel should stay at Z1=0, Z2=0 phase.

4.2.3 USB function Description

【Descriptor in USB Mode】

Descriptor Type	Byte1	Byte2	Byte3	Byte4	Byte5	Byte6	Byte7	Byte8
Device Descriptor	12	01	10	01	00	00	00	08
	VID1	VID0	PID1	PID0	REV1	REV0	00	02
	00	01						
Configuration Descriptor	09	02	22	00	01	01	00	A0
	32							
Interface Descriptor	09	04	00	00	01	03	01	02
	00							
HID Descriptor	09	21	11	01	00	01	22	34
	00							
Endpoint	07	05	81	03	08	00	0A	
HID Report Descriptor	05	01	09	02	A1	01	09	01
	A1	00	05	09	19	01	29	03
	15	00	25	01	95	03	75	01
	81	02	95	01	75	05	81	03
	05	01	09	30	09	31	09	38
	15	81	25	7F	75	08	95	03
	81	06	C0	C0				

- * VID : Vendor ID (Default = 0x1267)
- * PID : Product ID (Default = 0x0210)
- * REV : Revision Number = 0x2278
- * Product String : "PS/2+USB MOUSE"

【USB Mouse Report Data Type】

Byte0	Bit7	Bit6	Bit5	Bit4	Bit3	Bit2	Bit1	Bit0
	0	0	0	0	0	M	R	L
Byte1	Bit7	Bit6	Bit5	Bit4	Bit3	Bit2	Bit1	Bit0
	X-AXIS							
Byte2	Bit7	Bit6	Bit5	Bit4	Bit3	Bit2	Bit1	Bit0
	Y-AXIS							
Byte3	Bit7	Bit6	Bit5	Bit4	Bit3	Bit2	Bit1	Bit0
	Z-AXIS							

5 Absolute Maximum Rating

Symbol	min	Max	unit
Temperature under bias	0	70	°C
Storage temperature	-65	150	°C
Input voltage	-0.5	6.0	V
Output voltage	-0.5	6.0	V

6 Electrical Characteristic

(T = 0°C ~70°C, V_{DD}=4.4~5.2V, V_{SS}=0V)

Symbol	Parameter	Condition	Min	Type	Max	Unit
3.3V Regulator						
VRag	Output voltage of 3.3v Regulator	VDD = 4.2V ~ 5.2V	3.0	3.3	3.6	V
VResetL	Low Power Reset detecting low Voltage			-	2.3	V
VResetH	Low Power Reset detecting high Voltage		2.4	-		V
MCU operating						
IIL	Input Leakage Current for input pins	VIN=VDD,VSS	-	-	1	μA
VIHX	Clock Input High Voltage	OSCI	2.5	-	-	V
VILX	Clock Input Low Voltage	OSCI	-	-	1.0	V
GPIO Pins						
VHL	High/Low level transfer point	Input		1.1	-	V
VOH	Output High Voltage	IDrive = 5.0mA	2.4	-	-	V
VOL	Output Low Voltage	ISink = 5.0mA	-	-	0.4	V
IPH	Input current with pull-high resistor	The input pin with internal pull-high resistor of Port6 or port7 is connected to VSS.	-	25	-	μA
IPL	Input current with pull-low resistor	The input pin with internal pull-low resistor of Port6 is connected to VDD.	-	330	-	μA
USB Interface						
VOH	Static Output High	USB operation Mode	2.8	-	3.6	V
VOL	Static Output Low		-	-	0.3	V
VDI	Differential Input Sensitivity		0.2	-	-	V
VCM	Differential Input Command Mode Range		0.8	-	2.5	V
VSE	Single Ended Receiver Threshold	USB operation Mode	0.8	-	2.0	V
CIN	Transceiver Capacitance		-	-	20	pF
VRG	Output Voltage of Internal Regulator		3.0	-	3.6	V
RPH	Internal Pull-high Resistor		-20%	1.5	+20%	k

7 Package Diagram

7.1 PDIP-18L 300MIL PACKAGE OUTLINE DIMENSION(Unit:mm)

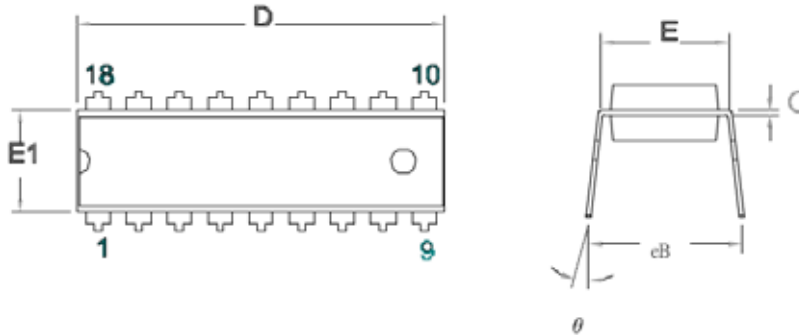

Symbol	Min	Normal	Max
A			4.450
A1	0.381		
A2	3.175	3.302	3.429
c	0.203	0.254	0.356
D	22.610	22.860	23.110
E1	6.220	6.438	6.655
E	7.370	7.620	7.870
eB	8.510	9.020	9.530
B	0.356	0.457	0.559
B1	1.143	1.524	1.778
L	3.048	3.302	3.556
e	2.540(TYP)		
θ	0		15

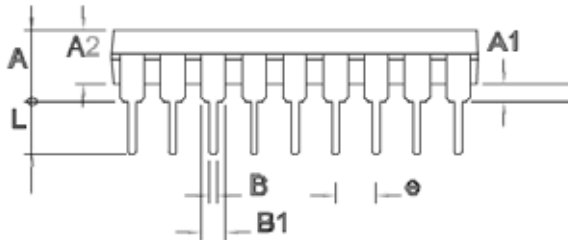

7.2 PDIP-20L 300MIL PACKAGE OUTLINE DIMENSION(Unit:mm)

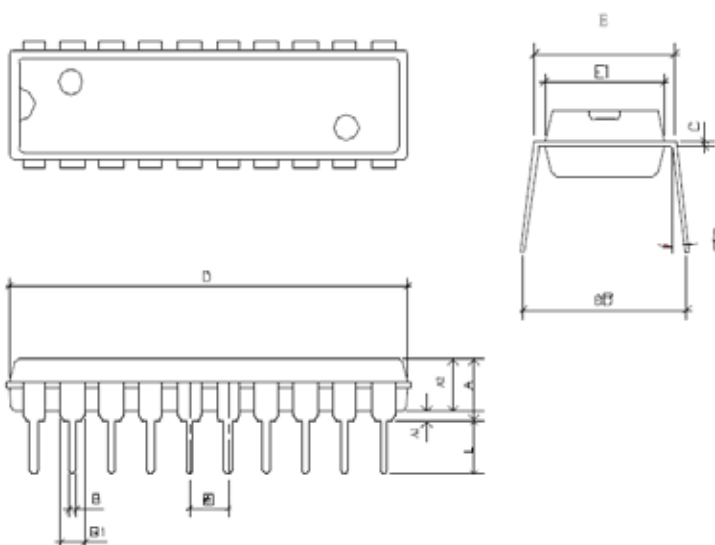

Symbol	Min	Normal	Max
A			4.450
A1	0.381		
A2	3.175	3.302	3.429
c	0.203	0.254	0.356
D	25.883	26.060	26.237
E1	6.220	6.438	6.655
E	7.370	7.620	7.870
eB	8.510	9.020	9.530
B	0.356	0.457	0.559
B1	1.143	1.524	1.778
L	3.048	3.302	3.556
e	2.540(TYP)		
θ	0		15

7.3 SOP-18L 300MIL PACKAGE OUTLINE DIMENSION(Unit:mm)

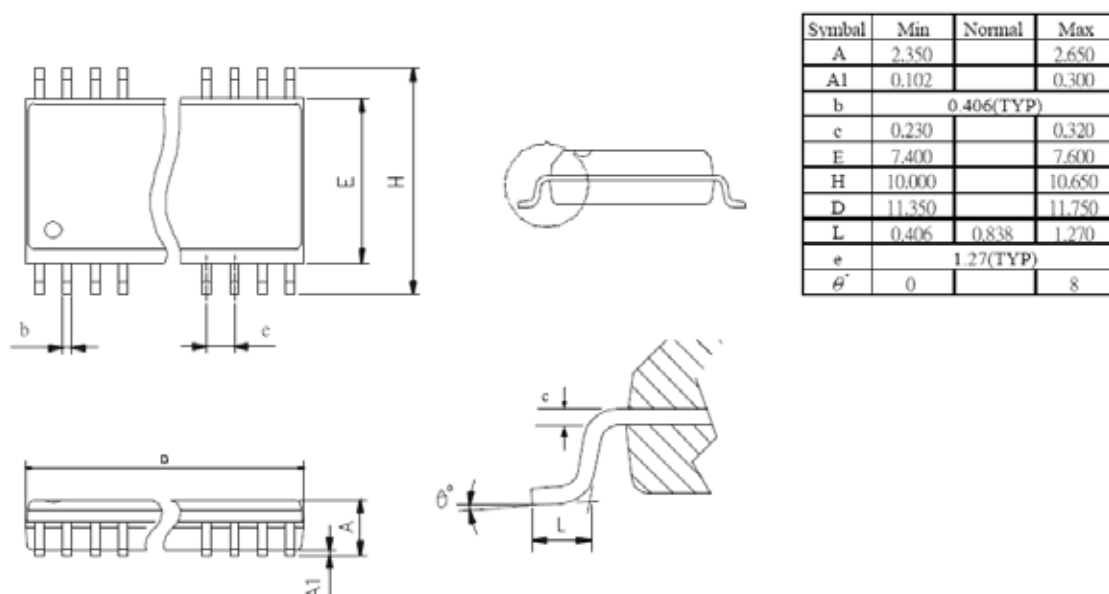

7.4 SOP-20L 300MIL PACKAGE OUTLINE DIMENSION(Unit:mm)

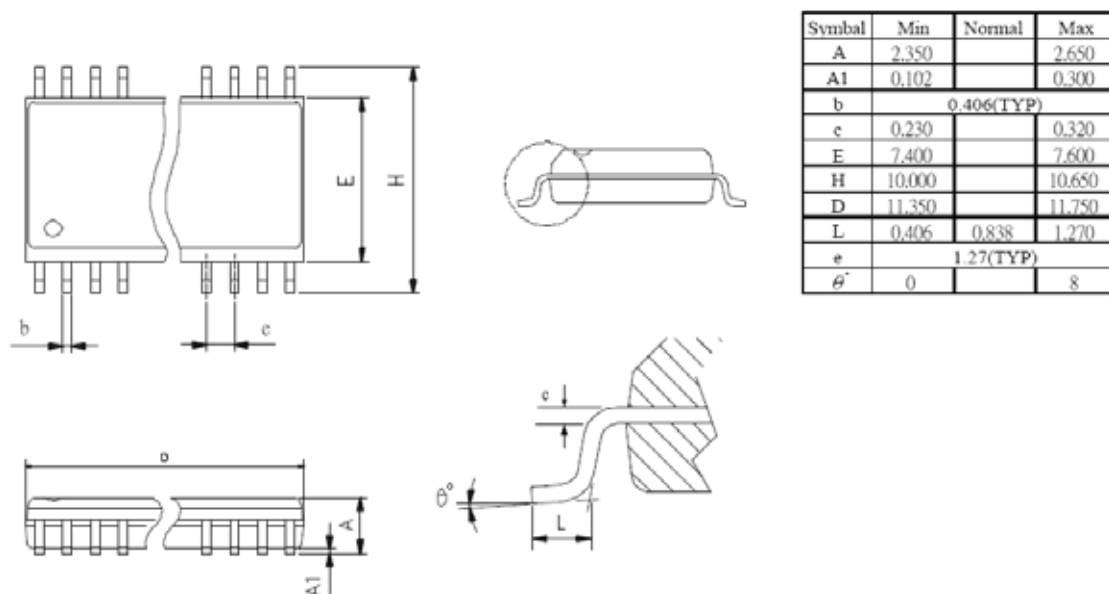

8 Pad List Information

8.1 eKM8022A Pad Configuration

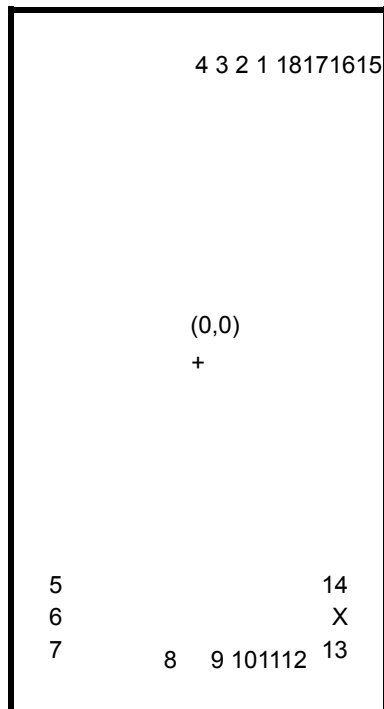

8.2 eKM8022A Pad Name & Coordinate Table

Chip Size : 1550*2660 UM		
Pad Number	Pad Name	Pad Coordinate (X, Y)
1	L_KEY / Z_SEL	188.9, 1210.0
2	IR_C	78.9, 1210.0
3	Z1	-31.1, 1210.0
4	Z2	-141.1, 1210.0
5	R_KEY	-655.0, -814.6
6	D_SEL	-655.0, -924.6
7	VSS	-655.0, -1034.6
8	V3.3	-301.8, -1210.0
9	OSCI	39.6, -1210.0
10	OSCO	149.6, -1210.0
11	VDD	259.6, -1210.0
12	D_MNS	369.6, -1210.0
13	D_PLUS	655.0, -1042.2
	NC	655.0, -927.2
14	M_KEY	655.0, -817.2
15	Y2	628.9, 1210.0
16	Y1	518.9, 1210.0
17	X2	408.9, 1210.0
18	X1	298.9, 1210.0

8.3 eKM8022B Pad Configuration

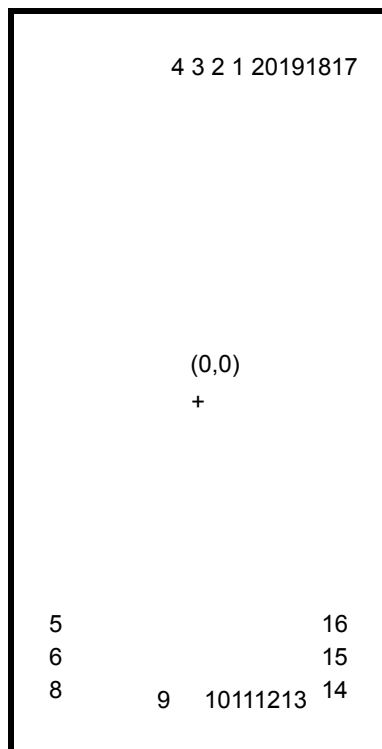

8.4 eKM8022B Pad Name & Coordinate Table

Chip Size : 1550*2660 UM		
Pad Number	Pad Name	Pad Coordinate (X, Y)
1	L_KEY / Z_SEL	188.9, 1210.0
2	IR_C	78.9, 1210.0
3	Z1	-31.1, 1210.0
4	Z2	-141.1, 1210.0
5	R_KEY	-655.0, -814.6
6	D_SEL	-655.0, -924.6
7		
8	VSS	-655.0, -1034.6
9	V3.3	-301.8, -1210.0
10	OSCI	39.6, -1210.0
11	OSCO	149.6, -1210.0
12	VDD	259.6, -1210.0
13	D_MNS	369.6, -1210.0
14	D_PLUS	655.0, -1042.2
15	IR_C2	655.0, -927.2
16	M_KEY	655.0, -817.2
17	Y2	628.9, 1210.0
18	Y1	518.9, 1210.0
19	X2	408.9, 1210.0
20	X1	298.9, 1210.0

9 Application Circuit

9.1 Notice Diagram

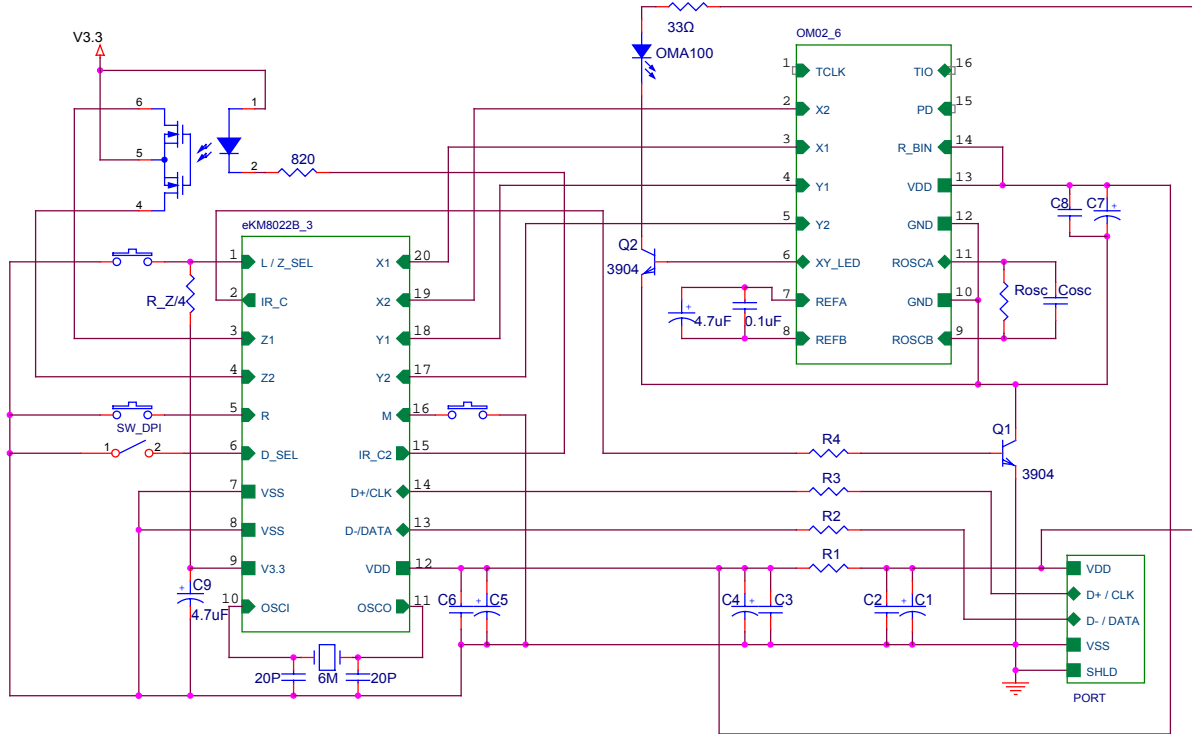

9.2 Components in Detail

TYPE	R1	R2	R3	R4	C1	C2	C3
NORMAL APPLICATION	10	-	-	1.5K	10uF	0.1uF(104)	-
EFT BETTER IMPROVEMENT		33	33				0.1uF(104)
TYPE	C4	C5	C6	C7	C8	C9	Cosc
NORMAL APPLICATION	-	10uF	0.1uF(104)	100uF	0.1uF(104)	4.7uF	-
EFT BETTER IMPROVEMENT	10uF						1nF(102)

- * * C5 & C6 have to be closed to MCU(VDD)
- * * C7 & C8 have to be closed to Sensor(VDD).
- * * C9 has to be closed to MCU(V3.3)
- * * R_Z/4 is Opened for Z/2 Type or 5.1K PULL-HIGH to V3.3 for Z/4 Type
- * * D_SEL(Pin#6) is floating for 400DPI or tied to GND for 800DPI.
- * * It's NOT recommended to use 800DPI mode in Ball Type.

9.3 eKM8022A_Mechanical Z/2 Application For Ball Type

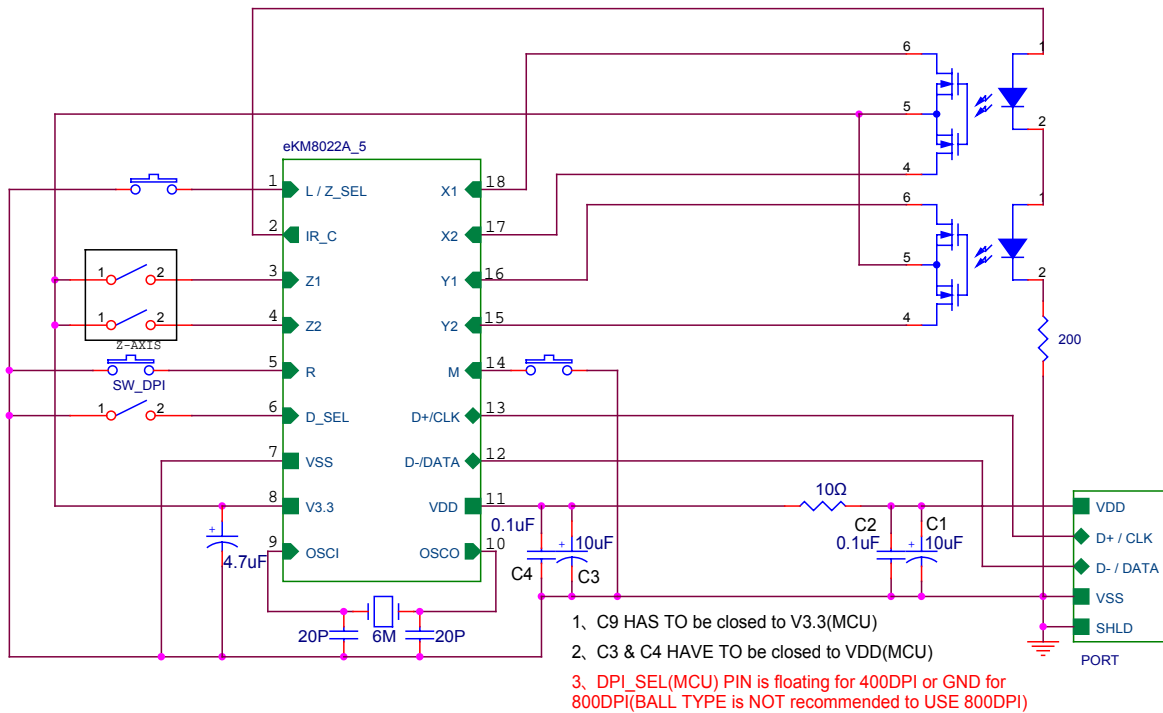

9.4 eKM8022B_Photo_Z/4 Application For Ball Type

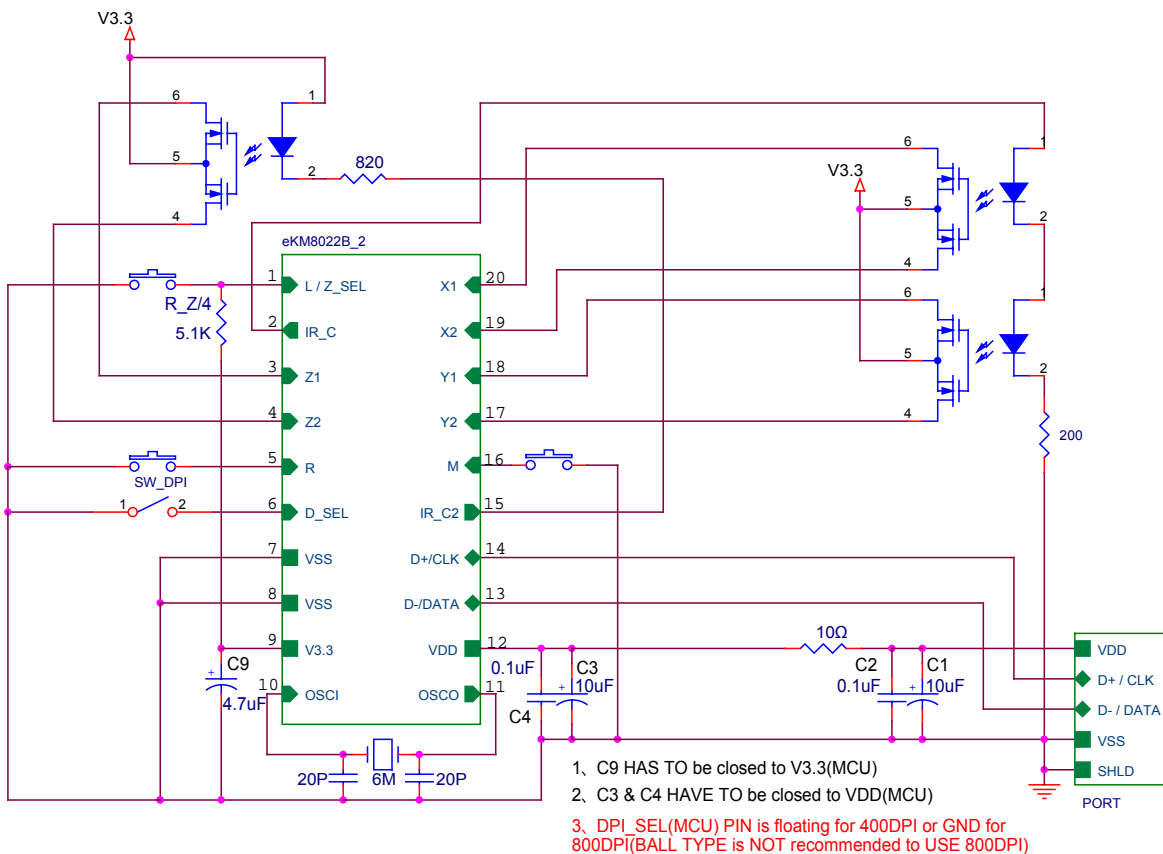

9.5 eKM8022A_Mechanical Z/2 Application For OM02

- 1, C9 HAS TO be closed to V3.3(MCU)
- 2, C3 & C4 HAVE TO be closed to VDD(MCU)
- 3, C5 & C6 HAVE TO be closed to VDD(SENSOR)
- 4, DPL_SEL(MCU) PIN is floating for 400DPI or GND for 800DPI

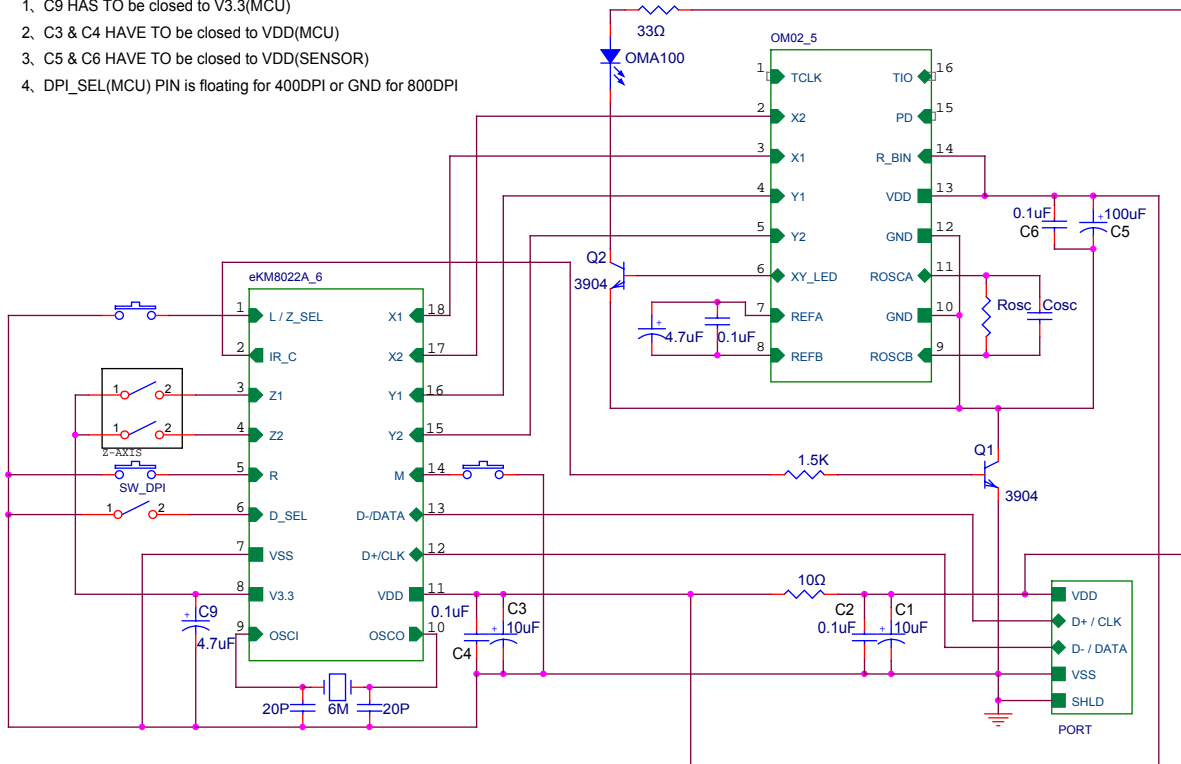

9.6 eKM8022B_Photo Z/4 Application For OM02

- 1, C9 HAS TO be closed to V3.3(MCU)
- 2, C3 & C4 HAVE TO be closed to VDD(MCU)
- 3, C5 & C6 HAVE TO be closed to VDD(SENSOR)
- 4, DPI_SEL(MCU) PIN is floating for 400DPI or GND for 800DPI

