

Silicon Controlled Rectifier Series 150C

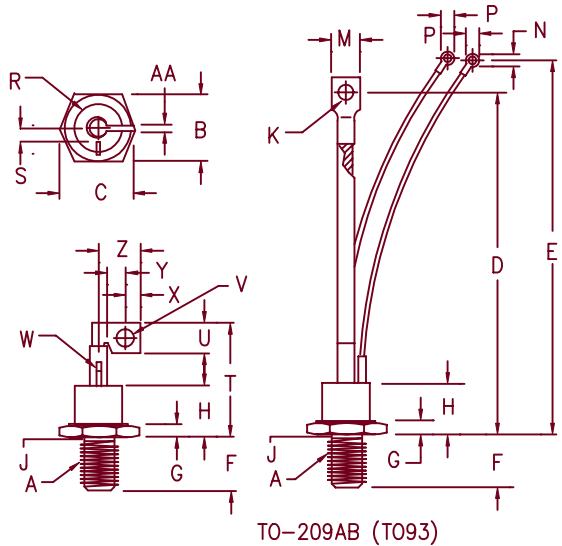

Notes:

- 3/4-16 UNF-3A
- Full thread within 2 1/2 threads
- For insulated cathode lead, add suffix "IL" to catalog number

Dim.	Inches		Millimeter		Notes
	Minimum	Maximum	Minimum	Maximum	
A	---	---	---	---	1
B	1.237	1.243	31.42	31.57	
C	1.350	1.360	34.29	34.54	
D	7.428	7.671	188.67	194.84	
E	7.382	8.100	187.50	205.74	
F	1.047	1.077	26.59	27.36	
G	.365	.385	9.27	9.78	
H	---	1.383	---	35.13	
J	.660	.749	16.76	19.02	2
K	.338	.348	8.59	8.84	Dia.
M	.625	.687	15.88	17.45	
N	.140	.150	3.56	3.81	
P	---	.295	---	7.49	
R	---	1.125	---	28.56	Dia.
S	.295	.305	7.49	7.75	
T	---	2.550	---	64.77	
U	.620	.630	15.75	16.00	
V	.276	.286	7.01	7.26	Dia.
W	.065	.075	1.65	1.91	Dia.
X	.245	.255	6.22	6.48	
Y	.243	---	6.17	---	
Z	.770	.790	19.56	20.07	
AA	.120	.130	3.05	3.30	

Microsemi Catalog Number	Forward & Reverse Repetitive Blocking	Reverse Transient Blocking
150C60B	600	700
150C80B	800	900
150C100B	1000	1100
150C120B	1200	1300

Add suffix "F" for flag lead
To specify dv/dt higher than 200V/usec., contact factory.

- High dv/dt-200 V/usec.
- 3000 Amperes surge current capability
- Low forward on-state voltage
- Primarily for line commutated converters
- Economical for general purpose phase control applications

Electrical Characteristics		
Max. RMS on-state current	$I_T(\text{RMS})$ 235 Amps	$T_C = 73^\circ\text{C}$
Max. average on-state cur.	$I_T(\text{AV})$ 150 Amps	$T_C = 73^\circ\text{C}$
Max. peak on-state voltage	V_{TM} 1.6 Volts	$I_{TM} = 500 \text{ A(peak)}$
Max. holding current	I_H 200 mA	
Max. peak one cycle surge current	I_{TSM} 3000A	$T_C = 73^\circ\text{C}, 60\text{Hz}$
Max. I^2t capability for fusing	I^2t 37,000A ² S	$t = 8.3 \text{ ms}$

Thermal and Mechanical Characteristics		
Operating junction temp range	T_J	-65°C to 125°C
Storage temperature range	T_{STG}	-65°C to 150°C
Maximum thermal resistance	$R_{\theta JC}$	0.20°C/W Junction to case
Typical thermal resistance (greased)	$R_{\theta CS}$	0.40°C/W Case to sink
Mounting torque		250-300 inch pounds
Weight		7.4 ounces (211.1 grams) typical

150C

Switching

Critical rate of rise of on-state current (note 1)	di/dt	100A/usec.	$T_J = 125^\circ\text{C}$
Typical delay time (note 1)	t_d	3.0 usec.	
Typical circuit commuted turn-off time (note 2)	t_q	100 usec.	$T_J = 125^\circ\text{C}$

Note 1: $I_{TM} = 100\text{A}$, $V_D = V_{DRM}$, $V_{GT} = 12\text{V}$ open circuit, 20 ohm-0.1 usec rise time

Note 2: $I_{TM} = 100\text{A}$, $di/dt = 5\text{A/usec}$, V_R during turn-off interval = 50V min, reapplied $dv/dt = 20\text{V/usec}$., linear to rated V_{DRM} , $V_{GT} = 0\text{V}$

Triggering

Max. gate voltage to trigger	V_{GT}	3.0V	$T_J = 25^\circ\text{C}$
Max. nontriggering gate voltage	V_{GD}	0.25V	$T_J = 125^\circ\text{C}$
Max. gate current to trigger	I_{GT}	150mA	$T_J = 25^\circ\text{C}$
Max. peak gate power	P_{GM}	10W	
Average gate power	$P_{G(AV)}$	2.0W	$t_p = 10 \text{ usec.}$
Max. peak gate current	I_{GM}	2.0A	
Max. peak gate voltage (forward)	V_{GM}	10V	
Max. peak gate voltage (reverse)	V_{GM}	5.0V	

Blocking

Max. leakage current	I_{DRM}	20mA	$T_J = 125^\circ\text{C} \ \& \ V_{DRM}$
Max. reverse leakage	I_{RRM}	20mA	$T_J = 125^\circ\text{C} \ \& \ V_{RRM}$
Critical rate of rise of off-state voltage	dv/dt	200V/usec.	$T_J = 125^\circ\text{C}$

150C

Figure 1
Typical Forward On-State Characteristics

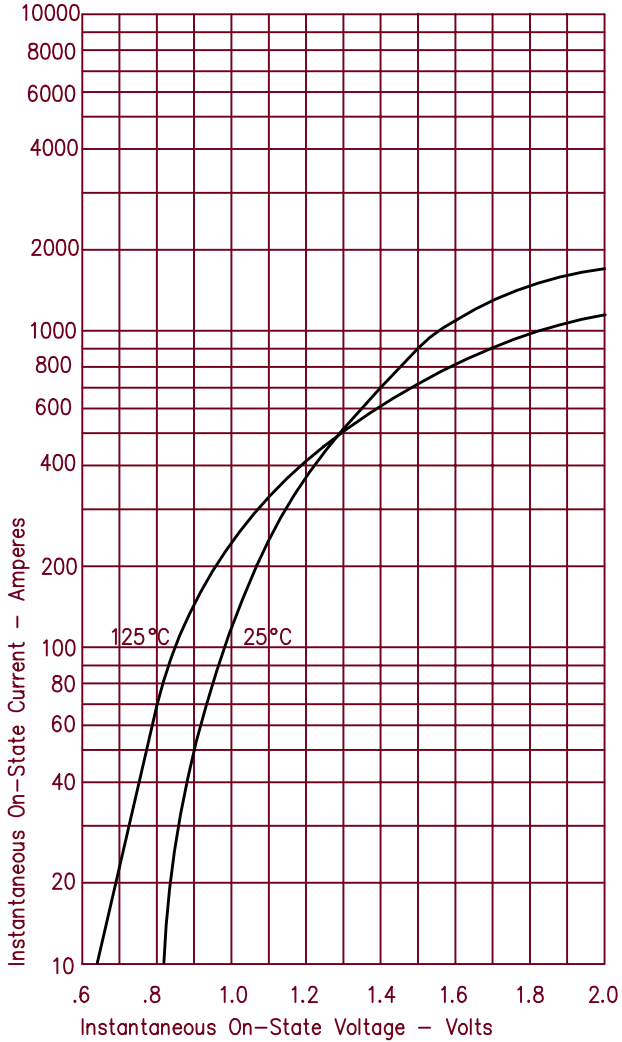

Figure 3
Maximum Power Dissipation

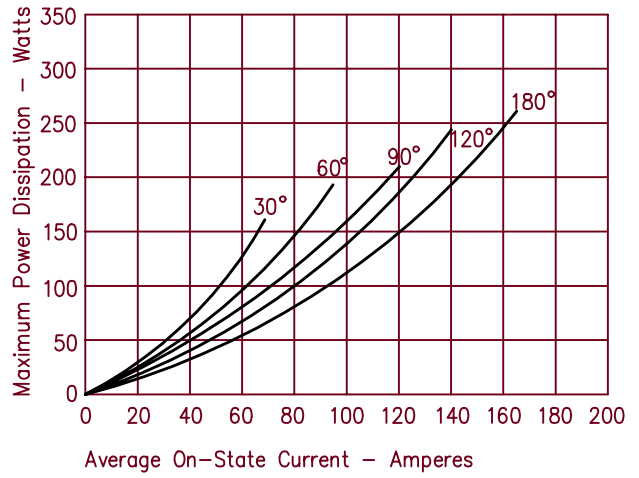

Figure 4
Transient Thermal Impedance

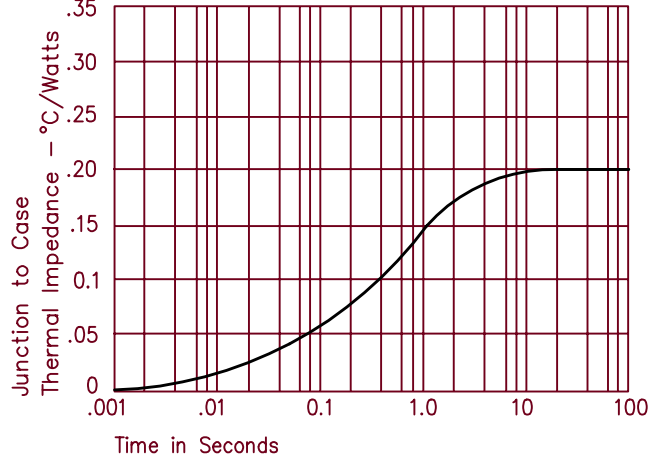

Figure 2
Forward Current Derating

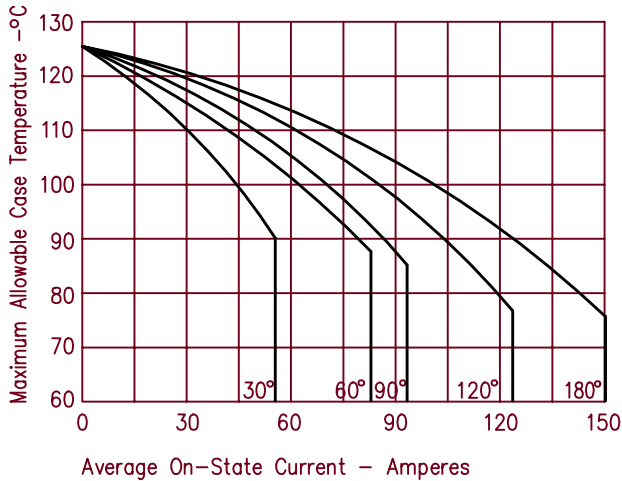

Figure 5
Maximum Nonrepetitive Surge Current

