

74AHC2G126; 74AHCT2G126

Dual buffer/line driver; 3-state

Rev. 02 — 21 September 2004

Product data sheet

1. General description

The 74AHC2G126; AHCT2G126 is a high-speed Si-gate CMOS device.

The 74AHC2G126; AHCT2G126 provides a dual non-inverting buffer/line driver with 3-state output. The 3-state output is controlled by the output enable input (OE). A LOW at pin nOE causes the output to assume a high-impedance OFF-state.

2. Features

- Symmetrical output impedance
- High noise immunity
- ESD protection:
 - ◆ HBM EIA/JESD22-A114-B exceeds 2000 V
 - ◆ MM EIA/JESD22-A115-A exceeds 200 V
 - ◆ CDM EIA/JESD22-C101 exceeds 1000 V.
- Low power dissipation
- Balanced propagation delays
- Multiple package options
- Specified from $-40\text{ }^{\circ}\text{C}$ to $+85\text{ }^{\circ}\text{C}$ and from $-40\text{ }^{\circ}\text{C}$ to $+125\text{ }^{\circ}\text{C}$.

3. Quick reference data

Table 1: Quick reference data

$GND = 0\text{ V}$; $T_{amb} = 25\text{ }^{\circ}\text{C}$; $t_r = t_f \leq 3.0\text{ ns}$.

Symbol	Parameter	Conditions	Min	Typ	Max	Unit
Type 74AHC2G126						
t_{PHL} , t_{PLH}	propagation delay nA to nY	$C_L = 15\text{ pF}$; $V_{CC} = 5\text{ V}$	-	3.4	5.5	ns
C_I	input capacitance		-	1.5	10	pF
C_{PD}	power dissipation capacitance	$C_L = 50\text{ pF}$; $f_i = 1\text{ MHz}$	[1] [2]	10	-	pF

PHILIPS

Table 1: Quick reference data ...continued $GND = 0\text{ V}$; $T_{amb} = 25\text{ °C}$; $t_r = t_f \leq 3.0\text{ ns}$.

Symbol	Parameter	Conditions	Min	Typ	Max	Unit
Type 74AHCT2G126						
t_{PHL} , t_{PLH}	propagation delay nA to nY	$C_L = 15\text{ pF}$; $V_{CC} = 5\text{ V}$	-	3.4	5.5	ns
C_I	input capacitance		-	1.5	10	pF
C_{PD}	power dissipation capacitance	$C_L = 50\text{ pF}$; $f_i = 1\text{ MHz}$ [1] [2]	-	10	-	pF

[1] C_{PD} is used to determine the dynamic power dissipation (P_D in μW).

$P_D = C_{PD} \times V_{CC}^2 \times f_i \times N + \Sigma(C_L \times V_{CC}^2 \times f_o)$ where:

f_i = input frequency in MHz;

f_o = output frequency in MHz;

C_L = output load capacitance in pF;

V_{CC} = supply voltage in Volts;

N = total load switching outputs;

$\Sigma(C_L \times V_{CC}^2 \times f_o)$ = sum of the outputs.

[2] The condition is $V_I = GND$ to V_{CC} .

4. Ordering information

Table 2: Ordering information

Type number	Package			
	Temperature range	Name	Description	Version
74AHC2G126DP	-40 °C to +125 °C	TSSOP8	plastic thin shrink small outline package; 8 leads; body width 3 mm; lead length 0.5 mm	SOT505-2
74AHCT2G126DP	-40 °C to +125 °C	TSSOP8	plastic thin shrink small outline package; 8 leads; body width 3 mm; lead length 0.5 mm	SOT505-2
74AHC2G126DC	-40 °C to +125 °C	VSSOP8	plastic very thin shrink small outline package; 8 leads; body width 2.3 mm	SOT765-1
74AHCT2G126DC	-40 °C to +125 °C	VSSOP8	plastic very thin shrink small outline package; 8 leads; body width 2.3 mm	SOT765-1
74AHC2G126GM	-40 °C to +125 °C	XSON8	plastic extremely thin small outline package; no leads; 8 terminals; body 0.95 × 1.95 × 0.5 mm	SOT833-1
74AHCT2G126GM	-40 °C to +125 °C	XSON8	plastic extremely thin small outline package; no leads; 8 terminals; body 0.95 × 1.95 × 0.5 mm	SOT833-1

5. Marking

Table 3: Marking

Type number	Marking code
74AHC2G126DP	A26
74AHCT2G126DP	C26
74AHC2G126DC	A26
74AHCT2G126DC	C26
74AHC2G126GM	A26
74AHCT2G126GM	C26

6. Functional diagram

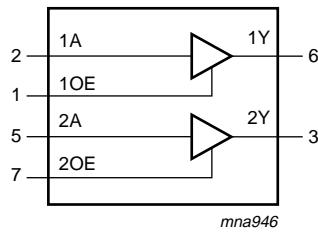

Fig 1. Logic symbol.

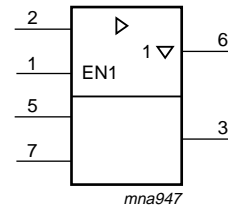

Fig 2. IEC logic symbol.

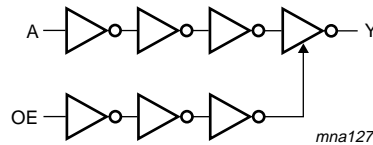
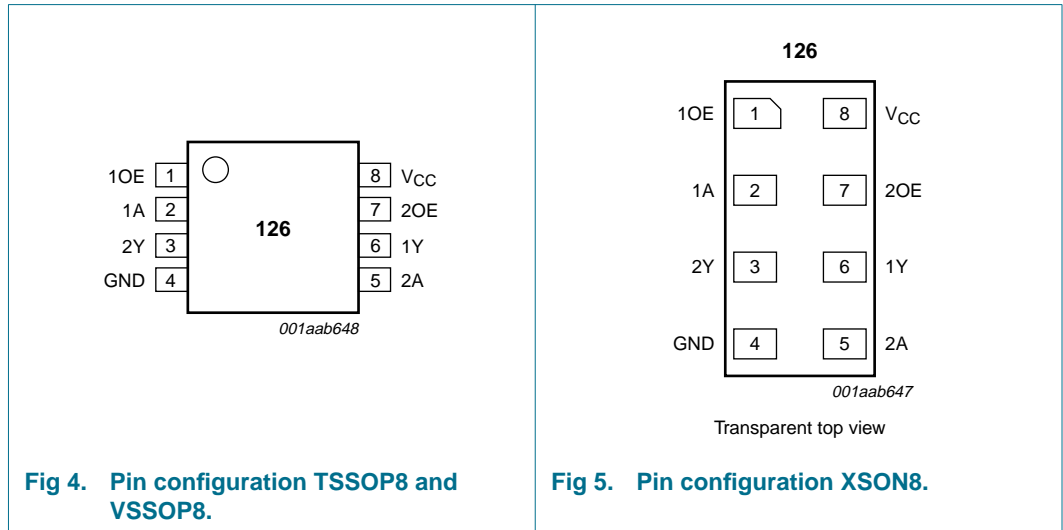

Fig 3. Logic diagram.

7. Pinning information

7.1 Pinning



7.2 Pin description

Table 4: Pin description

Symbol	Pin	Description
1OE	1	output enable input (active HIGH)
1A	2	data input
2Y	3	data output
GND	4	ground (0 V)
2A	5	data input
1Y	6	data output
2OE	7	output enable input (active HIGH)
V _{CC}	8	supply voltage

8. Functional description

8.1 Function table

Table 5: Function table ^[1]

Input		Output
nOE	nA	nY
H	L	L
H	H	H
L	X	Z

[1] H = HIGH voltage level;
 L = LOW voltage level;
 X = don't care;
 Z = high-impedance OFF-state.

9. Limiting values

Table 6: Limiting values

In accordance with the Absolute Maximum Rating System (IEC 60134). Voltages are referenced to GND (ground = 0 V).

Symbol	Parameter	Conditions	Min	Max	Unit
V_{CC}	supply voltage		-0.5	+7.0	V
V_I	input voltage		-0.5	+7.0	V
I_{IK}	input diode current	$V_I < -0.5$ V	-	-20	mA
I_{OK}	output diode current	$V_O < -0.5$ V or $V_O > V_{CC} + 0.5$ V ^[1]	-	±20	mA
I_O	output source or sink current	$V_O > -0.5$ V or $V_O < V_{CC} + 0.5$ V	-	±25	mA
I_{CC}, I_{GND}	V_{CC} or GND current		-	±75	mA
T_{stg}	storage temperature		-65	+150	°C
P_{tot}	power dissipation	$T_{amb} = -40$ °C to +125 °C	-	250	mW

[1] The input and output voltage ratings may be exceeded if the input and output current ratings are observed.

10. Recommended operating conditions

Table 7: Recommended operating conditions

Symbol	Parameter	Conditions	Min	Typ	Max	Unit
Type 74AHC2G126						
V_{CC}	supply voltage		2.0	5.0	5.5	V
V_I	input voltage		0	-	5.5	V
V_O	output voltage		0	-	V_{CC}	V
T_{amb}	operating ambient temperature	see Section 11 and Section 12 per device	-40	+25	+125	°C
t_r, t_f	input rise and fall times	$V_{CC} = 3.3$ V ± 0.3 V	-	-	100	ns/V
		$V_{CC} = 5.0$ V ± 0.5 V	-	-	20	ns/V

Table 7: Recommended operating conditions ...continued

Symbol	Parameter	Conditions	Min	Typ	Max	Unit
Type 74AHCT2G126						
V_{CC}	supply voltage		4.5	5.0	5.5	V
V_I	input voltage		0	-	5.5	V
V_O	output voltage		0	-	V_{CC}	V
T_{amb}	operating ambient temperature	see Section 11 and Section 12 per device	-40	+25	+125	°C
t_r, t_f	input rise and fall times	$V_{CC} = 5.0 V \pm 0.5 V$	-	-	20	ns/V

11. Static characteristics

Table 8: Static characteristics type 74AHC2G126

At recommended operating conditions; voltages are referenced to GND (ground = 0 V).

Symbol	Parameter	Conditions	Min	Typ	Max	Unit
$T_{amb} = 25\text{ °C}$						
V_{IH}	HIGH-level input voltage	$V_{CC} = 2.0 V$	1.5	-	-	V
		$V_{CC} = 3.0 V$	2.1	-	-	V
		$V_{CC} = 5.5 V$	3.85	-	-	V
V_{IL}	LOW-level input voltage	$V_{CC} = 2.0 V$	-	-	0.5	V
		$V_{CC} = 3.0 V$	-	-	0.9	V
		$V_{CC} = 5.5 V$	-	-	1.65	V
V_{OH}	HIGH-level output voltage	$V_I = V_{IH}$ or V_{IL}				
		$I_O = -50\text{ }\mu\text{A}$; $V_{CC} = 2.0 V$	1.9	2.0	-	V
		$I_O = -50\text{ }\mu\text{A}$; $V_{CC} = 3.0 V$	2.9	3.0	-	V
		$I_O = -50\text{ }\mu\text{A}$; $V_{CC} = 4.5 V$	4.4	4.5	-	V
		$I_O = -4.0\text{ mA}$; $V_{CC} = 3.0 V$	2.58	-	-	V
	$I_O = -8.0\text{ mA}$; $V_{CC} = 4.5 V$	3.94	-	-	V	
V_{OL}	LOW-level output voltage	$V_I = V_{IH}$ or V_{IL}				
		$I_O = 50\text{ }\mu\text{A}$; $V_{CC} = 2.0 V$	-	0	0.1	V
		$I_O = 50\text{ }\mu\text{A}$; $V_{CC} = 3.0 V$	-	0	0.1	V
		$I_O = 50\text{ }\mu\text{A}$; $V_{CC} = 4.5 V$	-	0	0.1	V
		$I_O = 4.0\text{ mA}$; $V_{CC} = 3.0 V$	-	-	0.36	V
	$I_O = 8.0\text{ mA}$; $V_{CC} = 4.5 V$	-	-	0.36	V	
I_{OZ}	3-state OFF-state current	$V_I = V_{CC}$ or GND; $V_{CC} = 5.5 V$	-	-	0.25	μA
I_{LI}	input leakage current	$V_I = V_{CC}$ or GND; $V_{CC} = 5.5 V$	-	-	0.1	μA
I_{CC}	quiescent supply current	$V_I = V_{CC}$ or GND; $I_O = 0 A$; $V_{CC} = 5.5 V$	-	-	1.0	μA
C_I	input capacitance		-	1.5	10	pF

Table 8: Static characteristics type 74AHC2G126 ...continued

At recommended operating conditions; voltages are referenced to GND (ground = 0 V).

Symbol	Parameter	Conditions	Min	Typ	Max	Unit
$T_{amb} = -40\text{ °C to }+85\text{ °C}$						
V_{IH}	HIGH-level input voltage	$V_{CC} = 2.0\text{ V}$	1.5	-	-	V
		$V_{CC} = 3.0\text{ V}$	2.1	-	-	V
		$V_{CC} = 5.5\text{ V}$	3.85	-	-	V
V_{IL}	LOW-level input voltage	$V_{CC} = 2.0\text{ V}$	-	-	0.5	V
		$V_{CC} = 3.0\text{ V}$	-	-	0.9	V
		$V_{CC} = 5.5\text{ V}$	-	-	1.65	V
V_{OH}	HIGH-level output voltage	$V_I = V_{IH}$ or V_{IL}				
		$I_O = -50\text{ }\mu\text{A}$; $V_{CC} = 2.0\text{ V}$	1.9	-	-	V
		$I_O = -50\text{ }\mu\text{A}$; $V_{CC} = 3.0\text{ V}$	2.9	-	-	V
		$I_O = -50\text{ }\mu\text{A}$; $V_{CC} = 4.5\text{ V}$	4.4	-	-	V
		$I_O = -4.0\text{ mA}$; $V_{CC} = 3.0\text{ V}$	2.48	-	-	V
	$I_O = -8.0\text{ mA}$; $V_{CC} = 4.5\text{ V}$	3.8	-	-	V	
V_{OL}	LOW-level output voltage	$V_I = V_{IH}$ or V_{IL}				
		$I_O = 50\text{ }\mu\text{A}$; $V_{CC} = 2.0\text{ V}$	-	-	0.1	V
		$I_O = 50\text{ }\mu\text{A}$; $V_{CC} = 3.0\text{ V}$	-	-	0.1	V
		$I_O = 50\text{ }\mu\text{A}$; $V_{CC} = 4.5\text{ V}$	-	-	0.1	V
		$I_O = 4.0\text{ mA}$; $V_{CC} = 3.0\text{ V}$	-	-	0.44	V
	$I_O = 8.0\text{ mA}$; $V_{CC} = 4.5\text{ V}$	-	-	0.44	V	
I_{OZ}	3-state OFF-state current	$V_I = V_{CC}$ or GND; $V_{CC} = 5.5\text{ V}$	-	-	2.5	μA
I_{LI}	input leakage current	$V_I = V_{CC}$ or GND; $V_{CC} = 5.5\text{ V}$	-	-	1.0	μA
I_{CC}	quiescent supply current	$V_I = V_{CC}$ or GND; $I_O = 0\text{ A}$; $V_{CC} = 5.5\text{ V}$	-	-	10	μA
C_I	input capacitance		-	-	10	pF
$T_{amb} = -40\text{ °C to }+125\text{ °C}$						
V_{IH}	HIGH-level input voltage	$V_{CC} = 2.0\text{ V}$	1.5	-	-	V
		$V_{CC} = 3.0\text{ V}$	2.1	-	-	V
		$V_{CC} = 5.5\text{ V}$	3.85	-	-	V
V_{IL}	LOW-level input voltage	$V_{CC} = 2.0\text{ V}$	-	-	0.5	V
		$V_{CC} = 3.0\text{ V}$	-	-	0.9	V
		$V_{CC} = 5.5\text{ V}$	-	-	1.65	V
V_{OH}	HIGH-level output voltage	$V_I = V_{IH}$ or V_{IL}				
		$I_O = -50\text{ }\mu\text{A}$; $V_{CC} = 2.0\text{ V}$	1.9	-	-	V
		$I_O = -50\text{ }\mu\text{A}$; $V_{CC} = 3.0\text{ V}$	2.9	-	-	V
		$I_O = -50\text{ }\mu\text{A}$; $V_{CC} = 4.5\text{ V}$	4.4	-	-	V
		$I_O = -4.0\text{ mA}$; $V_{CC} = 3.0\text{ V}$	2.40	-	-	V
	$I_O = -8.0\text{ mA}$; $V_{CC} = 4.5\text{ V}$	3.70	-	-	V	

Table 8: Static characteristics type 74AHC2G126 ...continued

At recommended operating conditions; voltages are referenced to GND (ground = 0 V).

Symbol	Parameter	Conditions	Min	Typ	Max	Unit
V _{OL}	LOW-level output voltage	V _I = V _{IH} or V _{IL}				
		I _O = 50 μA; V _{CC} = 2.0 V	-	-	0.1	V
		I _O = 50 μA; V _{CC} = 3.0 V	-	-	0.1	V
		I _O = 50 μA; V _{CC} = 4.5 V	-	-	0.1	V
		I _O = 4.0 mA; V _{CC} = 3.0 V	-	-	0.55	V
		I _O = 8.0 mA; V _{CC} = 4.5 V	-	-	0.55	V
I _{OZ}	3-state OFF-state current	V _I = V _{CC} or GND; V _{CC} = 5.5 V	-	-	10	μA
I _{LI}	input leakage current	V _I = V _{CC} or GND; V _{CC} = 5.5 V	-	-	2.0	μA
I _{CC}	quiescent supply current	V _I = V _{CC} or GND; I _O = 0 A; V _{CC} = 5.5 V	-	-	40	μA
C _I	input capacitance		-	-	10	pF

Table 9: Static characteristics type 74AHCT2G126

At recommended operating conditions; voltages are referenced to GND (ground = 0 V).

Symbol	Parameter	Conditions	Min	Typ	Max	Unit
T_{amb} = 25 °C						
V _{IH}	HIGH-level input voltage	V _{CC} = 4.5 V to 5.5 V	2.0	-	-	V
V _{IL}	LOW-level input voltage	V _{CC} = 4.5 V to 5.5 V	-	-	0.8	V
V _{OH}	HIGH-level output voltage	V _I = V _{IH} or V _{IL}				
		I _O = -50 μA; V _{CC} = 4.5 V	4.4	4.5	4.5	V
		I _O = -8.0 mA; V _{CC} = 4.5 V	3.94	-	-	V
V _{OL}	LOW-level output voltage	V _I = V _{IH} or V _{IL}				
		I _O = 50 μA; V _{CC} = 4.5 V	-	0	0.1	V
		I _O = 8.0 mA; V _{CC} = 4.5 V	-	-	0.36	V
I _{OZ}	3-state OFF-state current	V _I = V _{CC} or GND; V _{CC} = 5.5 V	-	-	0.25	μA
I _{LI}	input leakage current	V _I = V _{IH} or V _{IL} ; V _{CC} = 5.5 V	-	-	0.1	μA
I _{CC}	quiescent supply current	V _I = V _{CC} or GND; I _O = 0 A; V _{CC} = 5.5 V	-	-	1.0	μA
ΔI _{CC}	additional quiescent supply current per input pin	V _I = 3.4 V; other inputs at V _{CC} or GND; I _O = 0 A; V _{CC} = 5.5 V	-	-	1.35	mA
C _I	input capacitance		-	1.5	10	pF
T_{amb} = -40 °C to +85 °C						
V _{IH}	HIGH-level input voltage	V _{CC} = 4.5 V to 5.5 V	2.0	-	-	V
V _{IL}	LOW-level input voltage	V _{CC} = 4.5 V to 5.5 V	-	-	0.8	V

Table 9: Static characteristics type 74AHCT2G126 ...continued

At recommended operating conditions; voltages are referenced to GND (ground = 0 V).

Symbol	Parameter	Conditions	Min	Typ	Max	Unit
V _{OH}	HIGH-level output voltage	V _I = V _{IH} or V _{IL}				
		I _O = -50 μA; V _{CC} = 4.5 V	4.4	-	-	V
		I _O = -8.0 mA; V _{CC} = 4.5 V	3.8	-	-	V
V _{OL}	LOW-level output voltage	V _I = V _{IH} or V _{IL}				
		I _O = 50 μA; V _{CC} = 4.5 V	-	-	0.1	V
		I _O = 8.0 mA; V _{CC} = 4.5 V	-	-	0.44	V
I _{OZ}	3-state OFF-state current	V _I = V _{CC} or GND; V _{CC} = 5.5 V	-	-	2.5	μA
I _{LI}	input leakage current	V _I = V _{IH} or V _{IL} ; V _{CC} = 5.5 V	-	-	1.0	μA
I _{CC}	quiescent supply current	V _I = V _{CC} or GND; I _O = 0 A; V _{CC} = 5.5 V	-	-	10	μA
ΔI _{CC}	additional quiescent supply current per input pin	V _I = 3.4 V; other inputs at V _{CC} or GND; I _O = 0 A; V _{CC} = 5.5 V	-	-	1.5	mA
C _I	input capacitance		-	-	10	pF
T_{amb} = -40 °C to +125 °C						
V _{IH}	HIGH-level input voltage	V _{CC} = 4.5 V to 5.5 V	2.0	-	-	V
V _{IL}	LOW-level input voltage	V _{CC} = 4.5 V to 5.5 V	-	-	0.8	V
V _{OH}	HIGH-level output voltage	V _I = V _{IH} or V _{IL}				
		I _O = -50 μA; V _{CC} = 4.5 V	4.4	-	-	V
		I _O = -8.0 mA; V _{CC} = 4.5 V	3.70	-	-	V
V _{OL}	LOW-level output voltage	V _I = V _{IH} or V _{IL}				
		I _O = 50 μA; V _{CC} = 4.5 V	-	-	0.1	V
		I _O = 8.0 mA; V _{CC} = 4.5 V	-	-	0.55	V
I _{OZ}	3-state OFF-state current	V _I = V _{CC} or GND; V _{CC} = 5.5 V	-	-	10	μA
I _{LI}	input leakage current	V _I = V _{IH} or V _{IL} ; V _{CC} = 5.5 V	-	-	2.0	μA
I _{CC}	quiescent supply current	V _I = V _{CC} or GND; I _O = 0 A; V _{CC} = 5.5 V	-	-	40	μA
ΔI _{CC}	additional quiescent supply current per input pin	V _I = 3.4 V; other inputs at V _{CC} or GND; I _O = 0 A; V _{CC} = 5.5 V	-	-	1.5	mA
C _I	input capacitance		-	-	10	pF

12. Dynamic characteristics

Table 10: Dynamic characteristics type 74AHC2G126

$GND = 0\text{ V}$; $t_r = t_f \leq 3.0\text{ ns}$; see [Figure 8](#).

Symbol	Parameter	Test conditions	Min	Typ	Max	Unit	
$T_{amb} = 25\text{ °C}$							
t_{PHL} , t_{PLH}	propagation delay nA to nY	see Figure 6					
		$V_{CC} = 3.0\text{ V to }3.6\text{ V}$; $C_L = 15\text{ pF}$	[1]	-	4.7	8.0	ns
		$V_{CC} = 4.5\text{ V to }5.5\text{ V}$; $C_L = 15\text{ pF}$	[2]	-	3.4	5.5	ns
		$V_{CC} = 3.0\text{ V to }3.6\text{ V}$; $C_L = 50\text{ pF}$	[1]	-	6.6	11.5	ns
		$V_{CC} = 4.5\text{ V to }5.5\text{ V}$; $C_L = 50\text{ pF}$	[2]	-	4.8	7.5	ns
t_{PZH} , t_{PZL}	propagation delay nOE to nY	see Figure 7					
		$V_{CC} = 3.0\text{ V to }3.6\text{ V}$; $C_L = 15\text{ pF}$	[1]	-	5.0	8.0	ns
		$V_{CC} = 4.5\text{ V to }5.5\text{ V}$; $C_L = 15\text{ pF}$	[2]	-	3.6	5.1	ns
		$V_{CC} = 3.0\text{ V to }3.6\text{ V}$; $C_L = 50\text{ pF}$	[1]	-	6.9	11.5	ns
		$V_{CC} = 4.5\text{ V to }5.5\text{ V}$; $C_L = 50\text{ pF}$	[2]	-	4.9	7.5	ns
t_{PHZ} , t_{PLZ}	propagation delay nOE to nY	see Figure 7 ; $C_L = 15\text{ pF}$					
		$V_{CC} = 3.0\text{ V to }3.6\text{ V}$; $C_L = 15\text{ pF}$	[1]	-	6.0	9.7	ns
		$V_{CC} = 4.5\text{ V to }5.5\text{ V}$; $C_L = 15\text{ pF}$	[2]	-	4.1	6.8	ns
		$V_{CC} = 3.0\text{ V to }3.6\text{ V}$; $C_L = 50\text{ pF}$	[1]	-	8.3	13.2	ns
		$V_{CC} = 4.5\text{ V to }5.5\text{ V}$; $C_L = 50\text{ pF}$	[2]	-	5.7	8.8	ns
C_{PD}	power dissipation capacitance	$C_L = 50\text{ pF}$; $f_i = 1\text{ MHz}$	[3][4]	-	10	-	pF
$T_{amb} = -40\text{ °C to }+85\text{ °C}$							
t_{PHL} , t_{PLH}	propagation delay nA to nY	see Figure 6					
		$V_{CC} = 3.0\text{ V to }3.6\text{ V}$; $C_L = 15\text{ pF}$	1.0	-	9.5	ns	
		$V_{CC} = 4.5\text{ V to }5.5\text{ V}$; $C_L = 15\text{ pF}$	1.0	-	6.5	ns	
		$V_{CC} = 3.0\text{ V to }3.6\text{ V}$; $C_L = 50\text{ pF}$	1.0	-	13.0	ns	
		$V_{CC} = 4.5\text{ V to }5.5\text{ V}$; $C_L = 50\text{ pF}$	1.0	-	8.5	ns	
t_{PZH} , t_{PZL}	propagation delay nOE to nY	see Figure 7					
		$V_{CC} = 3.0\text{ V to }3.6\text{ V}$; $C_L = 15\text{ pF}$	1.0	-	9.5	ns	
		$V_{CC} = 4.5\text{ V to }5.5\text{ V}$; $C_L = 15\text{ pF}$	1.0	-	6.0	ns	
		$V_{CC} = 3.0\text{ V to }3.6\text{ V}$; $C_L = 50\text{ pF}$	1.0	-	13.0	ns	
		$V_{CC} = 4.5\text{ V to }5.5\text{ V}$; $C_L = 50\text{ pF}$	1.0	-	9.0	ns	
t_{PHZ} , t_{PLZ}	propagation delay nOE to nY	see Figure 7 ; $C_L = 15\text{ pF}$					
		$V_{CC} = 3.0\text{ V to }3.6\text{ V}$; $C_L = 15\text{ pF}$	1.0	-	11.5	ns	
		$V_{CC} = 4.5\text{ V to }5.5\text{ V}$; $C_L = 15\text{ pF}$	1.0	-	8.0	ns	
		$V_{CC} = 3.0\text{ V to }3.6\text{ V}$; $C_L = 50\text{ pF}$	1.0	-	15.0	ns	
		$V_{CC} = 4.5\text{ V to }5.5\text{ V}$; $C_L = 50\text{ pF}$	1.0	-	10.0	ns	

Table 10: Dynamic characteristics type 74AHC2G126 ...continuedGND = 0 V; $t_r = t_f \leq 3.0$ ns; see [Figure 8](#).

Symbol	Parameter	Test conditions	Min	Typ	Max	Unit
T_{amb} = -40 °C to +125 °C						
t _{PHL} , t _{PLH}	propagation delay nA to nY	see Figure 6				
		V _{CC} = 3.0 V to 3.6 V; C _L = 15 pF	1.0	-	11.5	ns
		V _{CC} = 4.5 V to 5.5 V; C _L = 15 pF	1.0	-	7.0	ns
		V _{CC} = 3.0 V to 3.6 V; C _L = 50 pF	1.0	-	14.5	ns
t _{PZH} , t _{PZL}	propagation delay nOE to nY	see Figure 7				
		V _{CC} = 3.0 V to 3.6 V; C _L = 15 pF	1.0	-	11.5	ns
		V _{CC} = 4.5 V to 5.5 V; C _L = 15 pF	1.0	-	6.5	ns
		V _{CC} = 3.0 V to 3.6 V; C _L = 50 pF	1.0	-	14.5	ns
t _{PHZ} , t _{PLZ}	propagation delay nOE to nY	see Figure 7 ; C _L = 15 pF				
		V _{CC} = 3.0 V to 3.6 V; C _L = 15 pF	1.0	-	12.5	ns
		V _{CC} = 4.5 V to 5.5 V; C _L = 15 pF	1.0	-	8.5	ns
		V _{CC} = 3.0 V to 3.6 V; C _L = 50 pF	1.0	-	16.5	ns
		V _{CC} = 4.5 V to 5.5 V; C _L = 50 pF	1.0	-	11.0	ns

[1] Typical values are measured at V_{CC} = 3.3 V.[2] Typical values are measured at V_{CC} = 5.0 V.[3] C_{PD} is used to determine the dynamic power dissipation (P_D in μW).P_D = C_{PD} × V_{CC}² × f_i × N + Σ(C_L × V_{CC}² × f_o) where:f_i = input frequency in MHz;f_o = output frequency in MHz;C_L = output load capacitance in pF;V_{CC} = supply voltage in Volts;

N = total load switching outputs;

Σ(C_L × V_{CC}² × f_o) = sum of the outputs.[4] The condition is V_I = GND to V_{CC}.**Table 11: Dynamic characteristics type 74AHCT2G126**GND = 0 V; $t_r = t_f \leq 3.0$ ns; V_{CC} = 4.5 V to 5.5 V; see [Figure 8](#)

Symbol	Parameter	Test conditions	Min	Typ	Max	Unit
T_{amb} = 25 °C [1]						
t _{PHL} , t _{PLH}	propagation delay nA to nY	see Figure 6				
		C _L = 15 pF	-	3.4	5.5	ns
		C _L = 50 pF	-	4.8	7.5	ns
t _{PZH} , t _{PZL}	propagation delay nOE to nY	see Figure 7				
		C _L = 15 pF	-	3.9	5.1	ns
		C _L = 50 pF	-	5.1	7.5	ns
t _{PHZ} , t _{PLZ}	propagation delay nOE to nY	see Figure 7				
		C _L = 15 pF	-	4.5	6.8	ns
		C _L = 50 pF	-	6.1	8.8	ns

Table 11: Dynamic characteristics type 74AHCT2G126 ...continued

GND = 0 V; $t_r = t_f \leq 3.0$ ns; $V_{CC} = 4.5$ V to 5.5 V; see [Figure 8](#)

Symbol	Parameter	Test conditions	Min	Typ	Max	Unit
C_{PD}	power dissipation capacitance	$C_L = 50$ pF; $f_i = 1$ MHz	[2] [3] -	10	-	pF
$T_{amb} = -40$ °C to $+85$ °C						
t_{PHL} , t_{PLH}	propagation delay nA to nY	see Figure 6				
		$C_L = 15$ pF	1.0	-	6.5	ns
		$C_L = 50$ pF	1.0	-	8.5	ns
t_{PZH} , t_{PZL}	propagation delay nOE to nY	see Figure 7				
		$C_L = 15$ pF	1.0	-	6.0	ns
		$C_L = 50$ pF	1.0	-	9.0	ns
t_{PHZ} , t_{PLZ}	propagation delay nOE to nY	see Figure 7				
		$C_L = 15$ pF	1.0	-	8.0	ns
		$C_L = 50$ pF	1.0	-	10.0	ns
$T_{amb} = -40$ °C to $+125$ °C						
t_{PHL} , t_{PLH}	propagation delay nA to nY	see Figure 6				
		$C_L = 15$ pF	1.0	-	7.0	ns
		$C_L = 50$ pF	1.0	-	9.5	ns
t_{PZH} , t_{PZL}	propagation delay nOE to nY	see Figure 7				
		$C_L = 15$ pF	1.0	-	6.5	ns
		$C_L = 50$ pF	1.0	-	9.5	ns
t_{PHZ} , t_{PLZ}	propagation delay nOE to nY	see Figure 7				
		$C_L = 15$ pF	1.0	-	8.5	ns
		$C_L = 50$ pF	1.0	-	11.0	ns

[1] Typical values are measured at $V_{CC} = 5.0$ V.[2] C_{PD} is used to determine the dynamic power dissipation (P_D in μ W). $P_D = C_{PD} \times V_{CC}^2 \times f_i \times N + \Sigma(C_L \times V_{CC}^2 \times f_o)$ where: f_i = input frequency in MHz; f_o = output frequency in MHz; C_L = output load capacitance in pF; V_{CC} = supply voltage in Volts;

N = total load switching outputs;

 $\Sigma(C_L \times V_{CC}^2 \times f_o)$ = sum of the outputs.[3] The condition is $V_i = \text{GND}$ to V_{CC} .

13. Waveforms

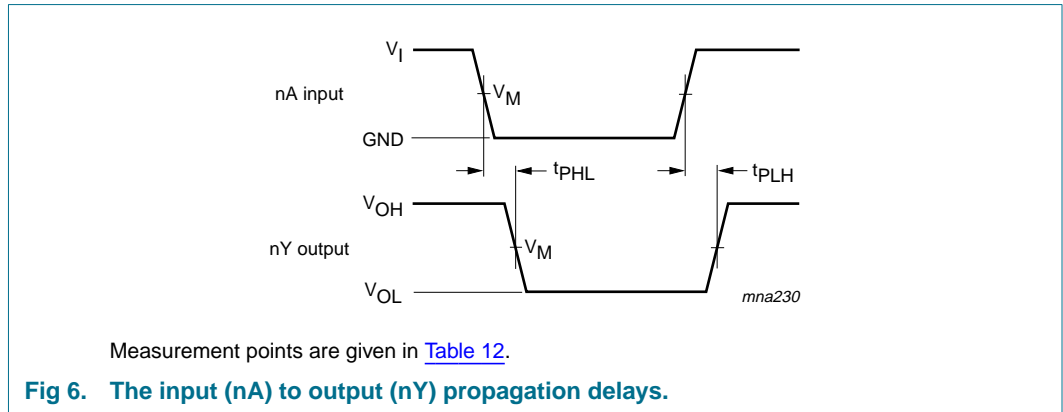
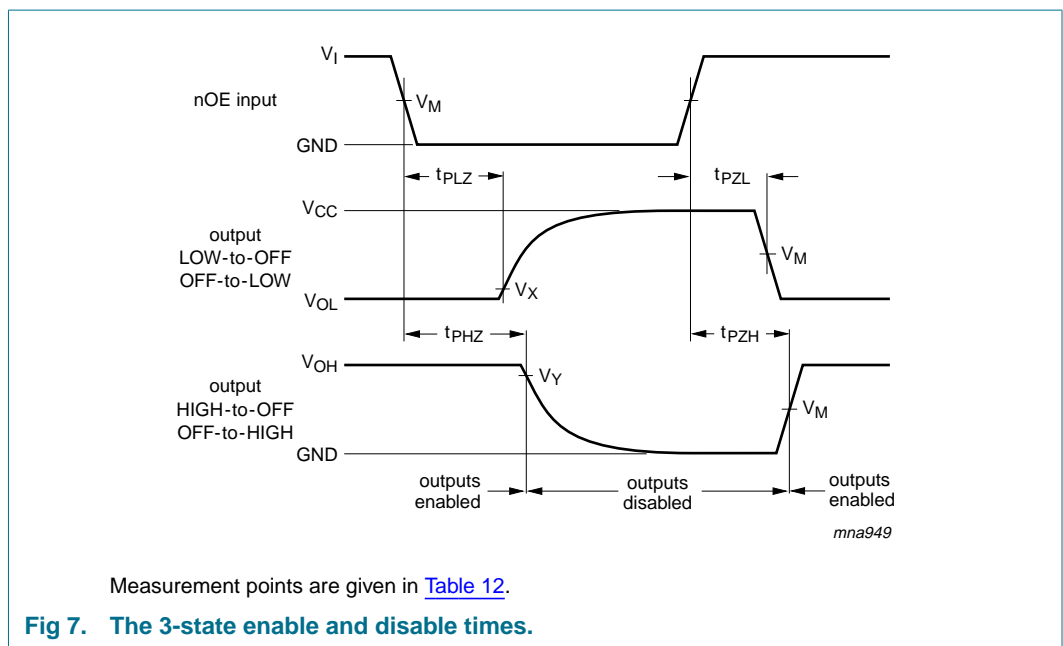
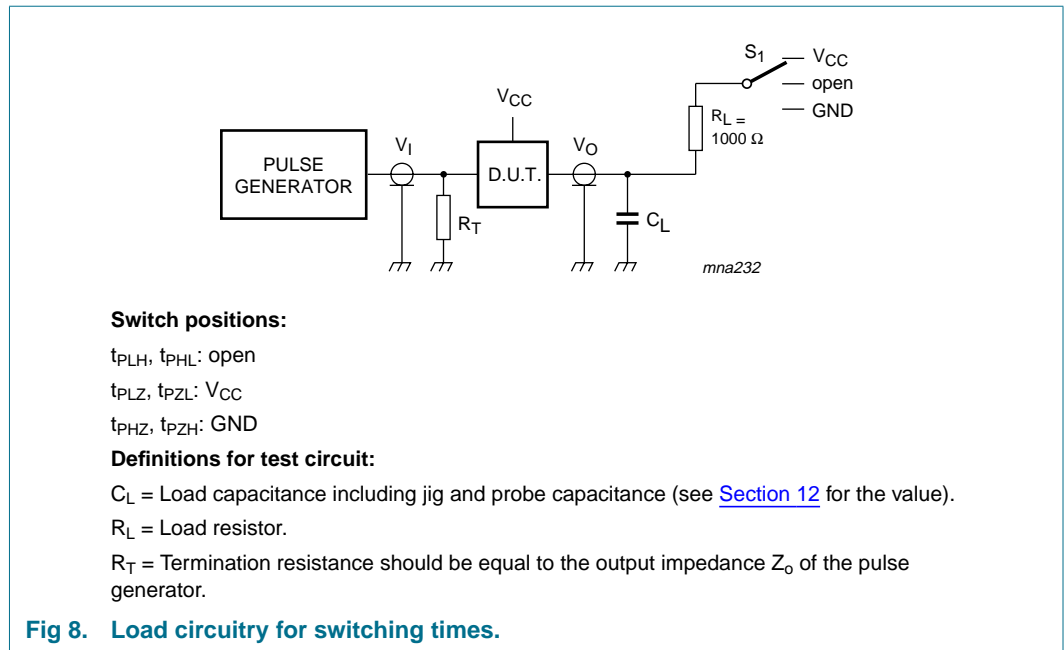

Table 12: Measurement points

Type	Input		Output		
	V_I	V_M	V_M	V_X	V_Y
74AHC2G126	GND to V_{CC}	50 % V_{CC}	50 % V_{CC}	$V_{OL} + 0.3 V$	$V_{OL} - 0.3 V$
74AHCT2G126	GND to 3.0 V	1.5 V	50 % V_{CC}	$V_{OL} + 0.3 V$	$V_{OL} - 0.3 V$





14. Package outline

TSSOP8: plastic thin shrink small outline package; 8 leads; body width 3 mm; lead length 0.5 mm SOT505-2

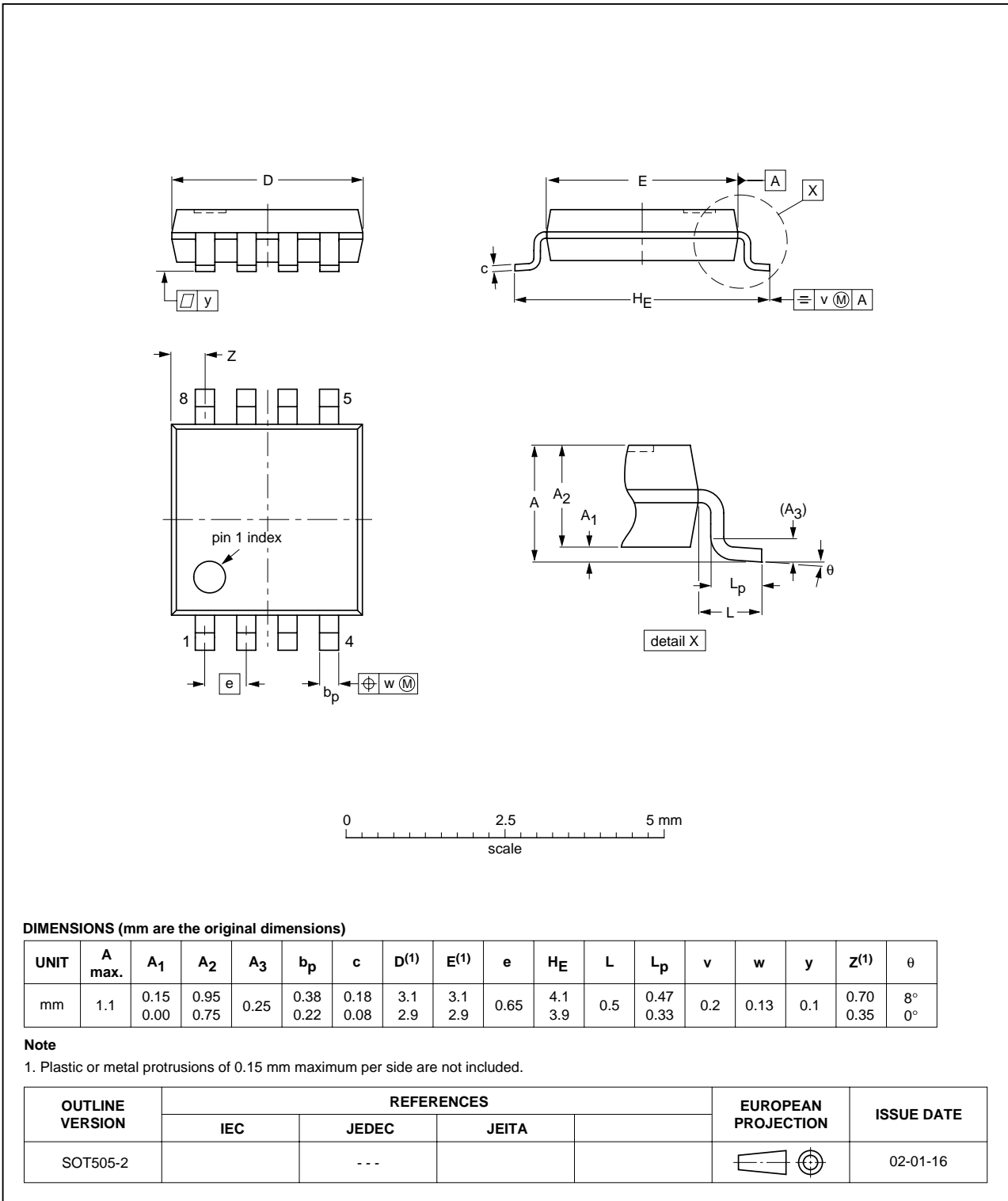

Fig 9. Package outline SOT505-2 (TSSOP8).

VSSOP8: plastic very thin shrink small outline package; 8 leads; body width 2.3 mm

SOT765-1

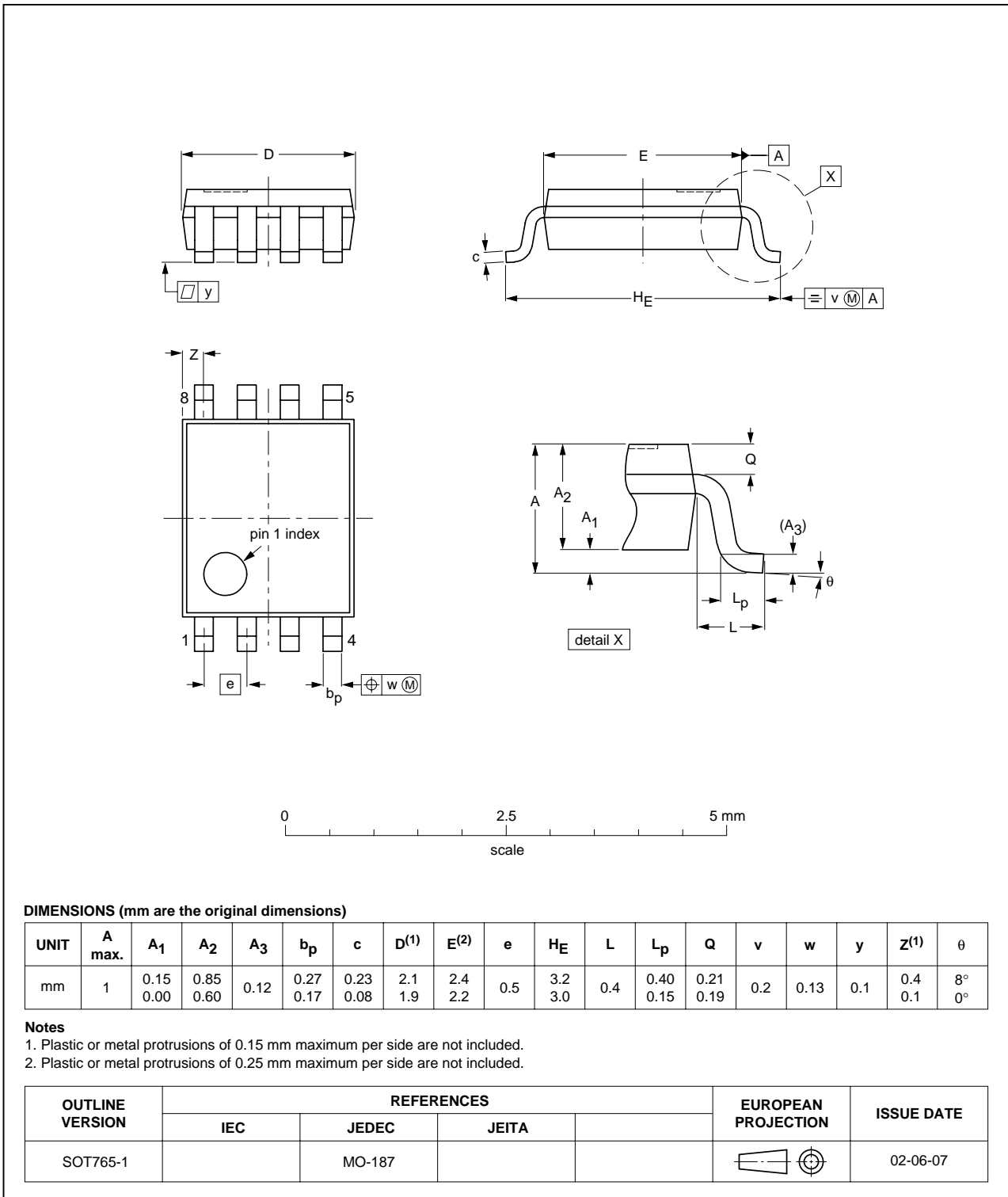

Fig 10. Package outline SOT765-1 (VSSOP8).

XSON8: plastic extremely thin small outline package; no leads; 8 terminals; body 0.95 x 1.95 x 0.5 mm

SOT833-1

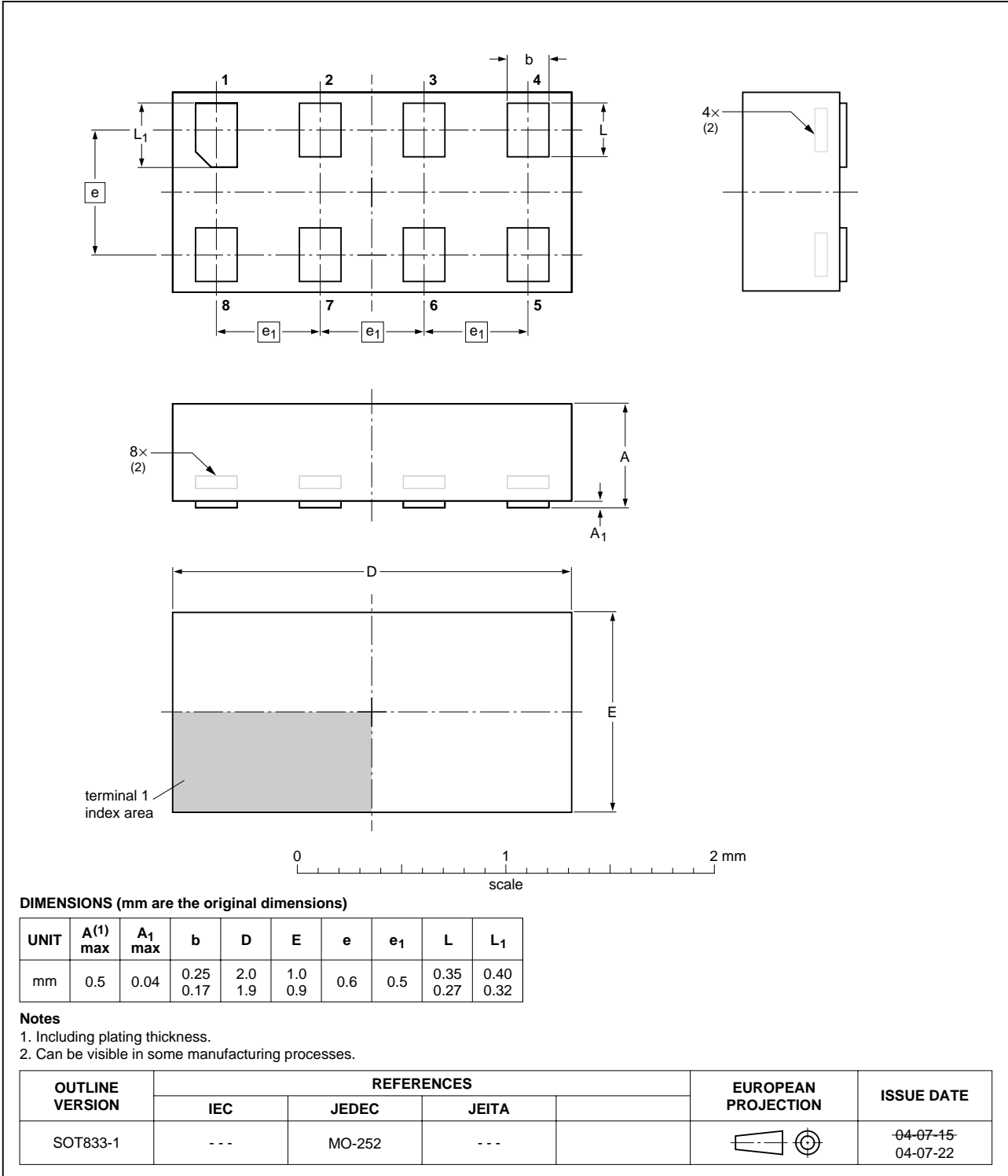

Fig 11. Package outline SOT833-1 (XSON8).

15. Revision history

Table 13: Revision history

Document ID	Release date	Data sheet status	Change notice	Order number	Supersedes
74AHC_AHCT2G126_2	20040921	Product data sheet	-	9397 750 13736	74AHC_AHCT2G126_1
Modification:	• Addition of SOT833-1 and Ordering information.				
74AHC_AHCT2G126_1	20040304	Product data sheet	-	9397 750 12698	-

16. Data sheet status

Level	Data sheet status ^[1]	Product status ^[2] ^[3]	Definition
I	Objective data	Development	This data sheet contains data from the objective specification for product development. Philips Semiconductors reserves the right to change the specification in any manner without notice.
II	Preliminary data	Qualification	This data sheet contains data from the preliminary specification. Supplementary data will be published at a later date. Philips Semiconductors reserves the right to change the specification without notice, in order to improve the design and supply the best possible product.
III	Product data	Production	This data sheet contains data from the product specification. Philips Semiconductors reserves the right to make changes at any time in order to improve the design, manufacturing and supply. Relevant changes will be communicated via a Customer Product/Process Change Notification (CPCN).

[1] Please consult the most recently issued data sheet before initiating or completing a design.

[2] The product status of the device(s) described in this data sheet may have changed since this data sheet was published. The latest information is available on the Internet at URL <http://www.semiconductors.philips.com>.

[3] For data sheets describing multiple type numbers, the highest-level product status determines the data sheet status.

17. Definitions

Short-form specification — The data in a short-form specification is extracted from a full data sheet with the same type number and title. For detailed information see the relevant data sheet or data handbook.

Limiting values definition — Limiting values given are in accordance with the Absolute Maximum Rating System (IEC 60134). Stress above one or more of the limiting values may cause permanent damage to the device. These are stress ratings only and operation of the device at these or at any other conditions above those given in the Characteristics sections of the specification is not implied. Exposure to limiting values for extended periods may affect device reliability.

Application information — Applications that are described herein for any of these products are for illustrative purposes only. Philips Semiconductors make no representation or warranty that such applications will be suitable for the specified use without further testing or modification.

18. Disclaimers

Life support — These products are not designed for use in life support appliances, devices, or systems where malfunction of these products can reasonably be expected to result in personal injury. Philips Semiconductors customers using or selling these products for use in such applications do so at their own risk and agree to fully indemnify Philips Semiconductors for any damages resulting from such application.

Right to make changes — Philips Semiconductors reserves the right to make changes in the products - including circuits, standard cells, and/or software - described or contained herein in order to improve design and/or performance. When the product is in full production (status 'Production'), relevant changes will be communicated via a Customer Product/Process Change Notification (CPCN). Philips Semiconductors assumes no responsibility or liability for the use of any of these products, conveys no license or title under any patent, copyright, or mask work right to these products, and makes no representations or warranties that these products are free from patent, copyright, or mask work right infringement, unless otherwise specified.

19. Contact information

For additional information, please visit: <http://www.semiconductors.philips.com>

For sales office addresses, send an email to: sales.addresses@www.semiconductors.philips.com

20. Contents

1	General description	1
2	Features	1
3	Quick reference data	1
4	Ordering information	2
5	Marking	3
6	Functional diagram	3
7	Pinning information	4
7.1	Pinning	4
7.2	Pin description	4
8	Functional description	5
8.1	Function table	5
9	Limiting values	5
10	Recommended operating conditions	5
11	Static characteristics	6
12	Dynamic characteristics	10
13	Waveforms	13
14	Package outline	15
15	Revision history	18
16	Data sheet status	19
17	Definitions	19
18	Disclaimers	19
19	Contact information	19



© Koninklijke Philips Electronics N.V. 2004

All rights are reserved. Reproduction in whole or in part is prohibited without the prior written consent of the copyright owner. The information presented in this document does not form part of any quotation or contract, is believed to be accurate and reliable and may be changed without notice. No liability will be accepted by the publisher for any consequence of its use. Publication thereof does not convey nor imply any license under patent- or other industrial or intellectual property rights.

Date of release: 21 September 2004
Document number: 9397 750 13736

Published in The Netherlands