

### IGBT MODULE

600V / 75A / PIM

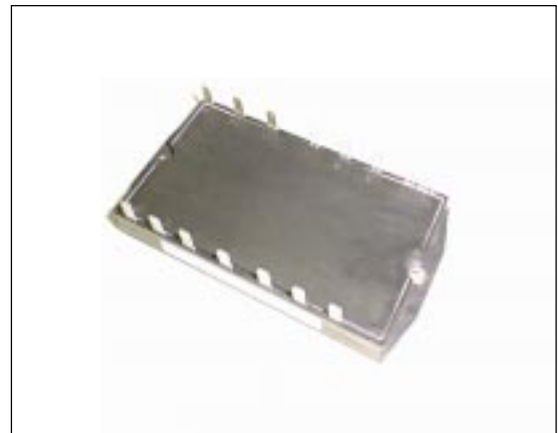

#### ■ Features

- High Speed Switching
- Voltage Drive
- Low Inductance Module Structure
- Converter Diode Bridge Dynamic Brake Circuit

#### ■ Applications

- Inverter for Motor Drive
- AC and DC Servo Drive Amplifier
- Uninterruptible Power Supply

#### ■ Maximum ratings and characteristics

● Absolute maximum ratings (Tc=25°C unless without specified)

Item	Symbol	Condition	Rating	Unit	
Inverter	Collector-Emitter voltage	V <sub>CES</sub>	600	V	
	Gate-Emitter voltage	V <sub>GES</sub>	±20	V	
	Collector current	I <sub>C</sub>	Continuous	75	A
		I <sub>CP</sub>	1ms	150	A
		-I <sub>C</sub>		75	A
Collector power dissipation	P <sub>C</sub>	1 device	300	W	
Brake	Collector-Emitter voltage	V <sub>CES</sub>	600	V	
	Gate-Emitter voltage	V <sub>GES</sub>	±20	V	
	Collector current	I <sub>C</sub>	Continuous	50	A
		I <sub>CP</sub>	1ms	100	A
	Collector power dissipation	P <sub>C</sub>	1 device	200	W
	Repetitive peak reverse voltage	V <sub>R<sub>RM</sub></sub>		600	V
	Average forward current	I <sub>F(AV)</sub>		1	A
Surge current	I <sub>FSM</sub>	10ms	50	A	
Converter	Repetitive peak reverse voltage	V <sub>R<sub>RM</sub></sub>	800	V	
	Non-Repetitive peak reverse voltage	V <sub>R<sub>S</sub></sub>	900	V	
	Average output current	I <sub>O</sub>	50/60Hz sine wave	50	A
	Surge current (Non-Repetitive)	I <sub>FSM</sub>	T <sub>J</sub> =150°C, 10ms	350	A
	I <sup>2</sup> t (Non-Repetitive)		T <sub>J</sub> =150°C, 10ms	648	A <sup>2</sup> s
Operating junction temperature	T <sub>J</sub>		+150	°C	
Storage temperature	T <sub>stg</sub>		-40 to +125	°C	
Isolation voltage	V <sub>iso</sub>	AC : 1 minute	AC 2500	V	
Mounting screw torque			1.7 * <sub>1</sub>	N·m	

\*<sub>1</sub> Recommendable value : 1.3 to 1.7 N·m (M4)

● **Electrical characteristics (T<sub>j</sub>=25°C unless without specified)**

Item	Symbol	Condition	Characteristics			Unit	
			Min.	Typ.	Max.		
Inverter (IGBT)	Zero gate voltage collector current	I <sub>CES</sub>	V <sub>CE</sub> =600V, V <sub>GE</sub> =0V			1.0	mA
	Gate-Emitter leakage current	I <sub>GES</sub>	V <sub>CE</sub> =0V, V <sub>GE</sub> =±20V			0.2	μA
	Gate-Emitter threshold voltage	V <sub>GE(th)</sub>	V <sub>CE</sub> =20V, I <sub>C</sub> =75mA			5.5	V
	Collector-Emitter saturation voltage	V <sub>CE(sat)</sub>	V <sub>GE</sub> =15V I <sub>C</sub> =75A	chip		2.8	V
				Terminal		3.1	V
	Collector-Emitter voltage	-V <sub>CE</sub>	-I <sub>C</sub> =75A	chip		3.0	V
				Terminal		3.3	V
	Input capacitance	C <sub>ies</sub>	V <sub>GE</sub> =0V, V <sub>CE</sub> =10V, f=1MHz			6000	pF
	Switching time	ton	V <sub>CC</sub> =300V			1.2	μs
		tr	I <sub>C</sub> =75A			0.6	μs
toff		V <sub>GE</sub> =±15V			1.0	μs	
tf		R <sub>G</sub> =33 ohm			0.35	μs	
Reverse recovery time of FRD	t <sub>rr</sub>	I <sub>F</sub> =75A			0.3	μs	
Brake (IGBT)	Zero gate voltage collector current	I <sub>CES</sub>	V <sub>CE</sub> =600V, V <sub>GE</sub> =0V			1.0	mA
	Gate-Emitter leakage current	I <sub>GES</sub>	V <sub>CE</sub> =0V, V <sub>GE</sub> =±20V			0.1	μA
	Collector-Emitter saturation voltage	V <sub>CE(sat)</sub>	I <sub>C</sub> =50A, V <sub>GE</sub> =15V			2.8	V
	Switching time	ton	V <sub>CC</sub> =300V			0.8	μs
		tr	I <sub>C</sub> =50A			0.6	μs
		toff	V <sub>GE</sub> =±15V			1.0	μs
tf		R <sub>G</sub> =51ohm			0.35	μs	
Brake (FWD)	Reverse current	I <sub>RRM</sub>	V <sub>R</sub> =600V			1	mA
	Reverse recovery time	t <sub>rr</sub>			0.6	μs	
Converter	Forward voltage	V <sub>FM</sub>	I <sub>F</sub> =50A			1.55	V
	Reverse current	I <sub>RRM</sub>	V <sub>R</sub> =800V			1.0	mA

● **Thermal Characteristics**

Item	Symbol	Condition	Characteristics			Unit
			Min.	Typ.	Max.	
Thermal resistance ( 1 device )	R <sub>th(j-c)</sub>	Inverter IGBT			0.42	°C/W
		Inverter FRD			1.10	
		Brake IGBT			0.63	
		Brake FRD			3.57	
		Converter Diode			2.10	
Contact thermal resistance *	R <sub>th(c-f)</sub>	With thermal compound		0.05		

\* This is the value which is defined mounting on the additional cooling fin with thermal compound

■ **Equivalent Circuit Schematic**

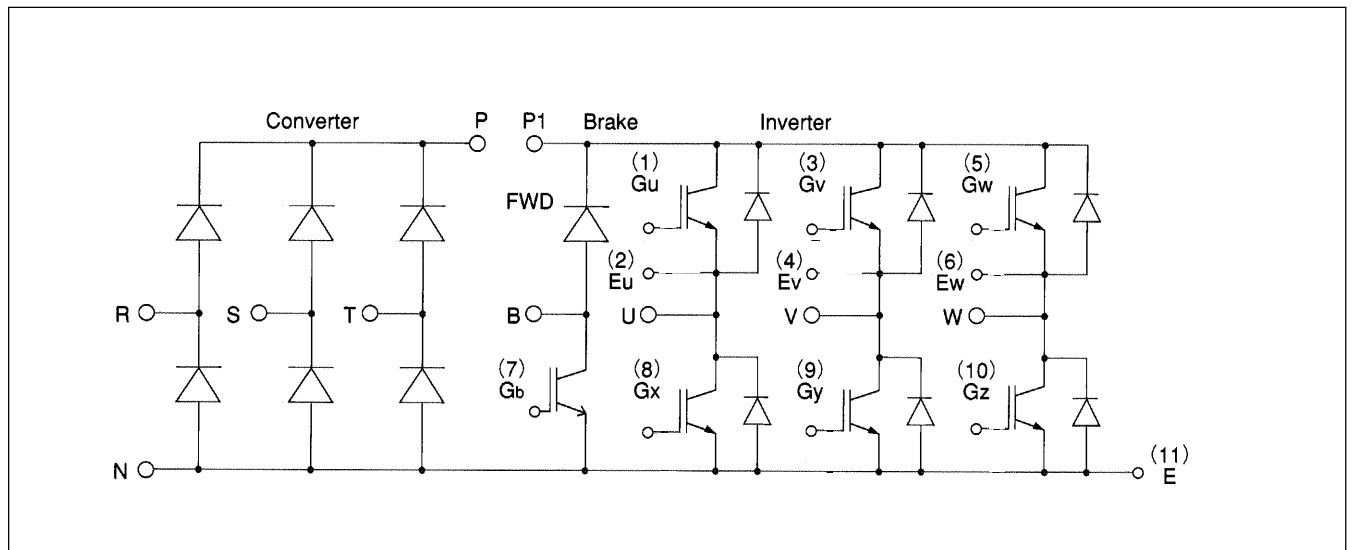

■ Characteristics (Representative)

● Inverter

Collector current vs. Collector-Emitter voltage  
T<sub>j</sub>=25°C

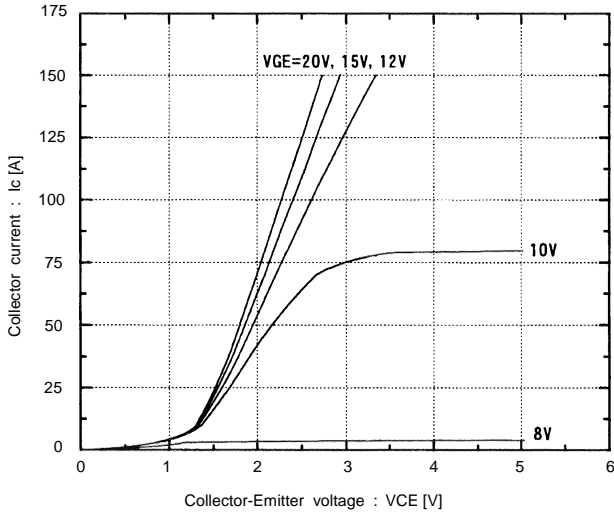

Collector current vs. Collector-Emitter voltage  
T<sub>j</sub>=125°C

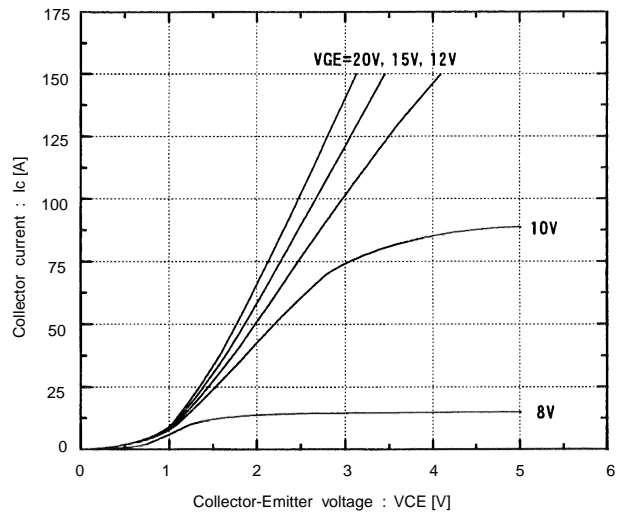

Collector-Emitter vs. Gate-Emitter voltage  
T<sub>j</sub>=25°C

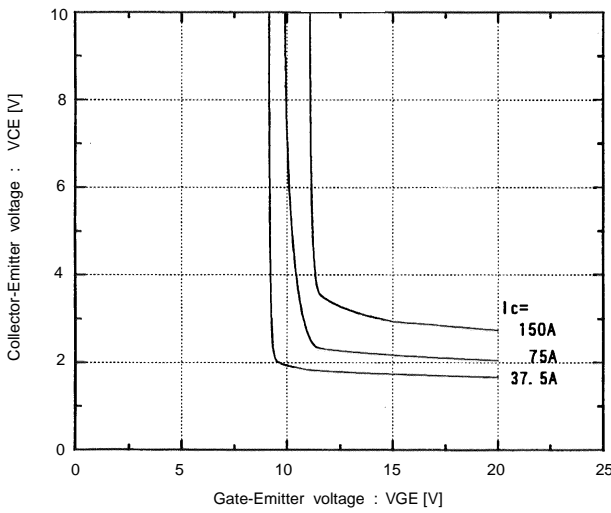

Collector-Emitter vs. Gate-Emitter voltage  
T<sub>j</sub>=125°C

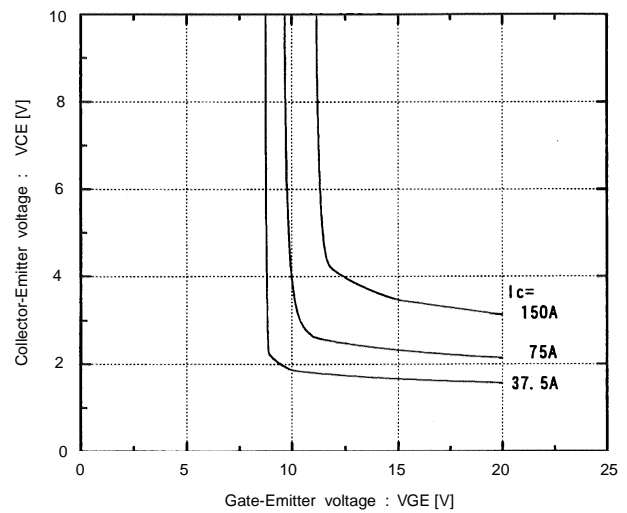

Switching time vs. Collector current  
V<sub>cc</sub>=300V, R<sub>G</sub>=33 ohm, V<sub>GE</sub>=±15V, T<sub>j</sub>=25°C

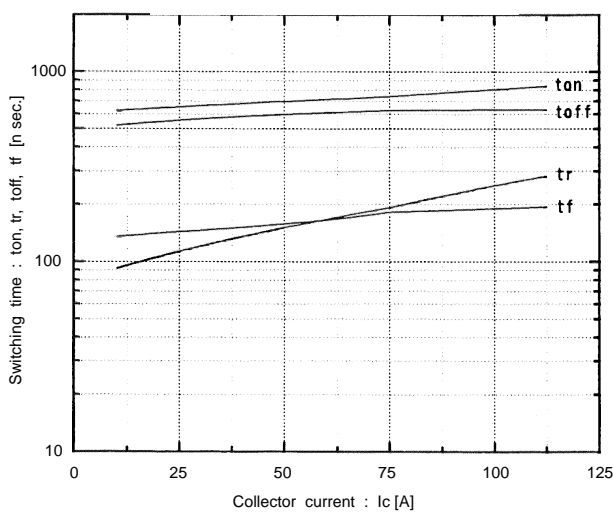

Switching time vs. Collector current  
V<sub>cc</sub>=300V, R<sub>G</sub>=33 ohm, V<sub>GE</sub>=±15V, T<sub>j</sub>=125°C

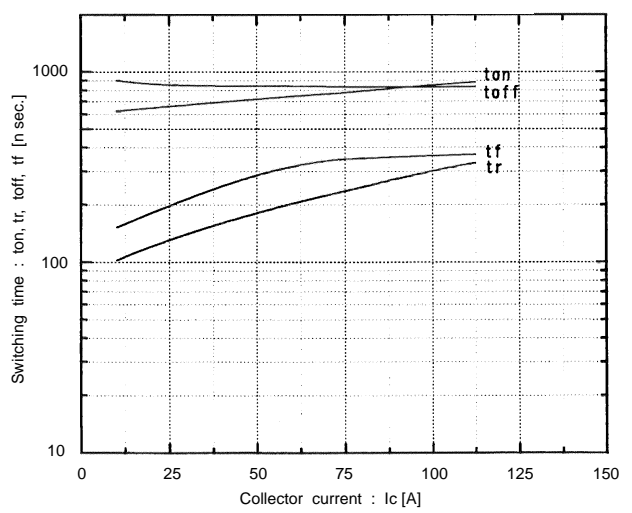

Switching time vs. RG  
 $V_{cc}=300V, I_c=75A, V_{GE}=\pm 15V, T_j=25^\circ C$

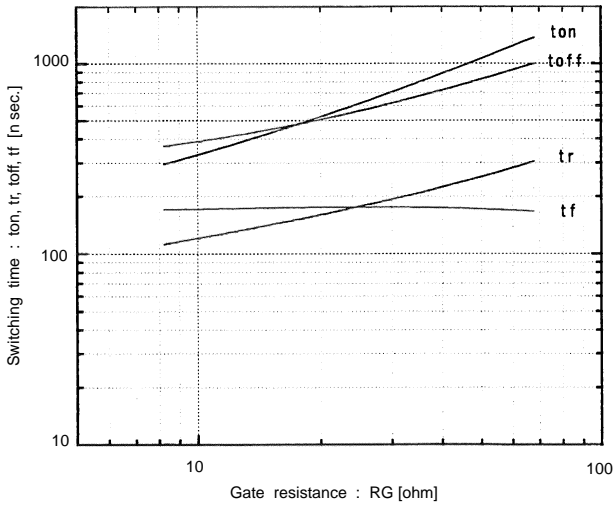

Dynamic input characteristics  
 $T_j=25^\circ C$

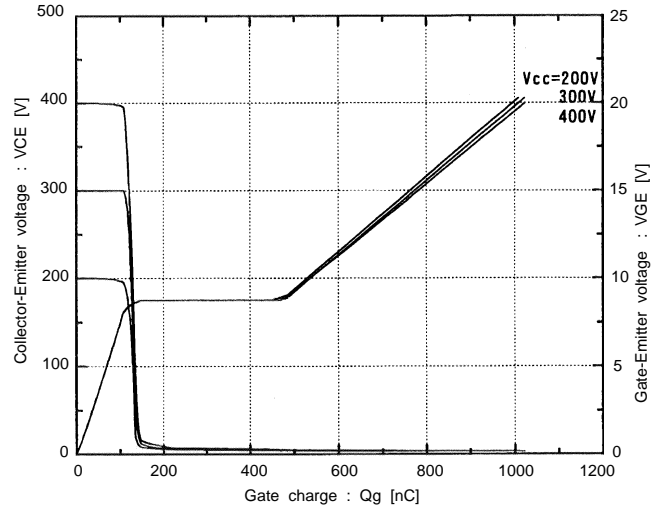

Forward current vs. Forward voltage  
 $V_{GE}=0V$

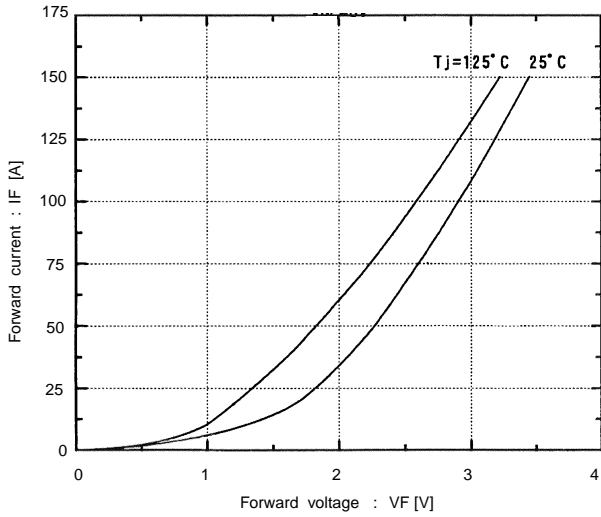

Reverse recovery characteristics  
 $t_{rr}, I_{rr}$  vs.  $I_F$

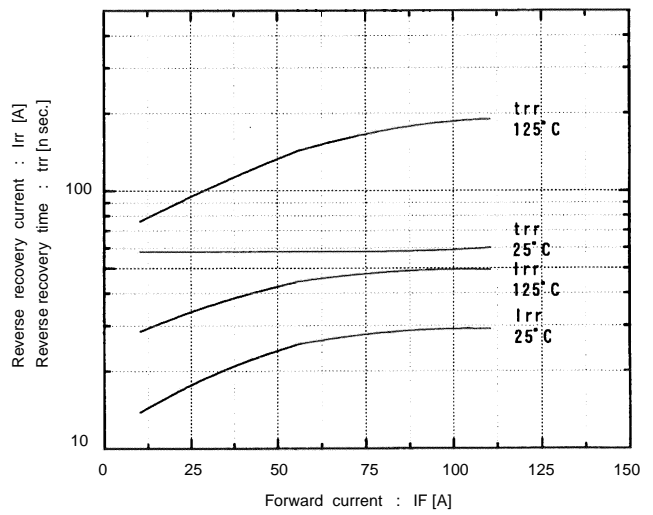

Transient thermal resistance

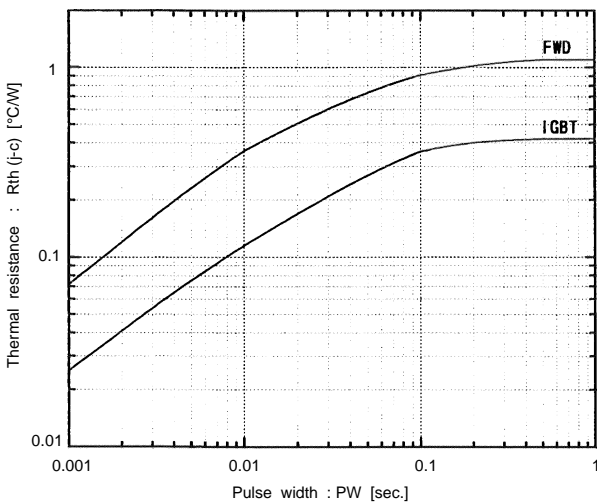

Reversed biased safe operating area  
 $+V_{GE}=15V, -V_{GE} \le 15V, T_j \le 125^\circ C, R_G \ge 33 \text{ ohm}$

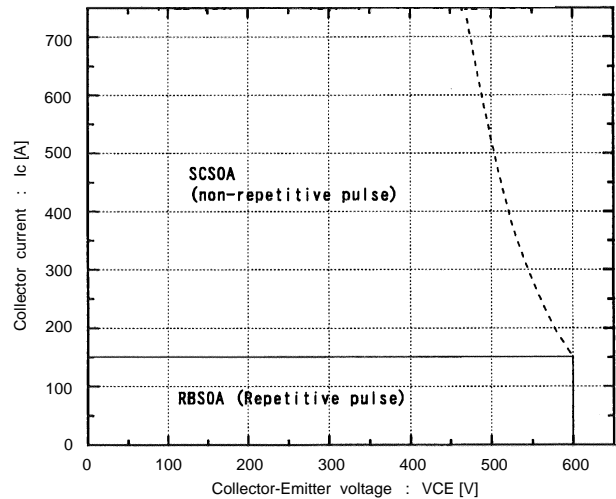

Switching loss vs. Collector current  
 $V_{cc}=300V, R_G=33\ \Omega, V_{GE}=\pm 15V$

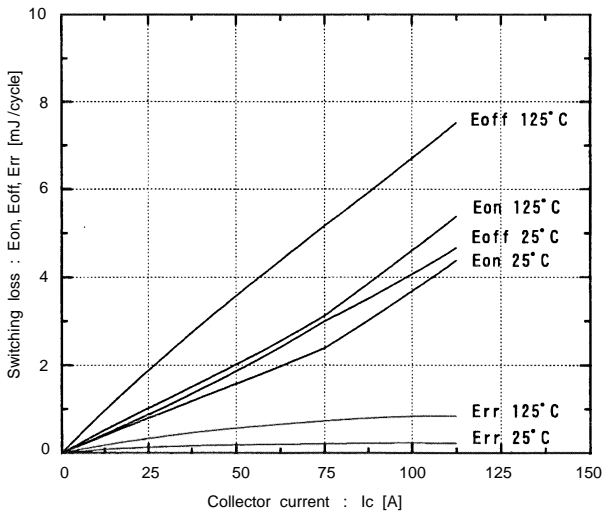

Capacitance vs. Collector-Emitter voltage  
 $T_j=25^\circ C$

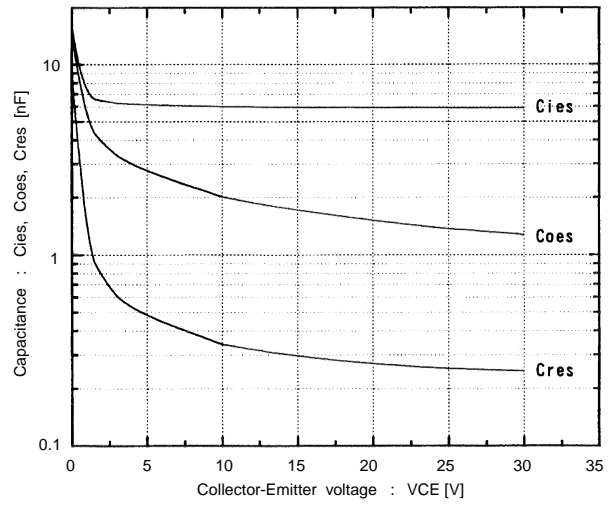

Converter Diode  
 Forward current vs. Forward voltage

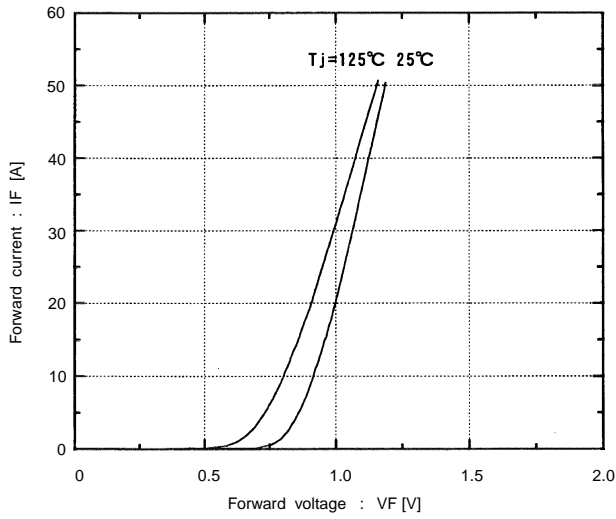

● Brake

Collector current vs. Collector-Emitter voltage  
T<sub>j</sub>=25°C

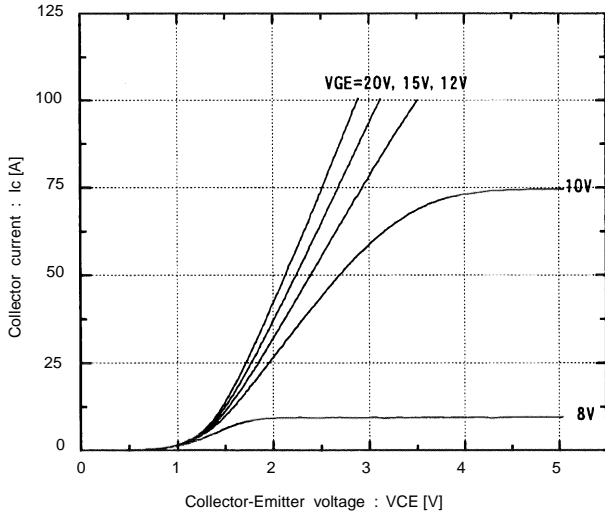

Collector current vs. Collector-Emitter voltage  
T<sub>j</sub>=125°C

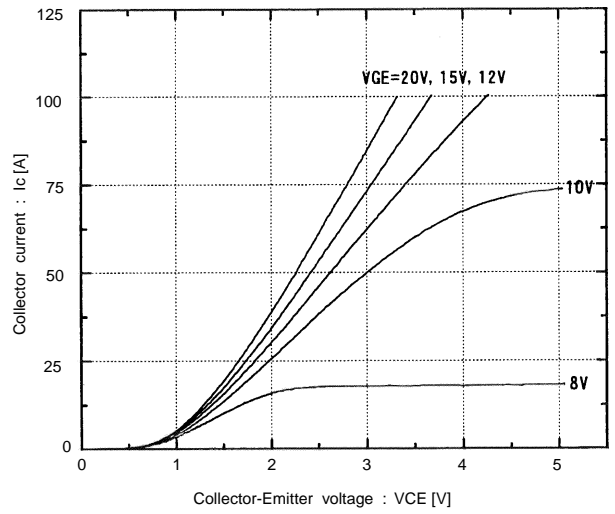

Collector-Emitter vs. Gate-Emitter voltage  
T<sub>j</sub>=25°C

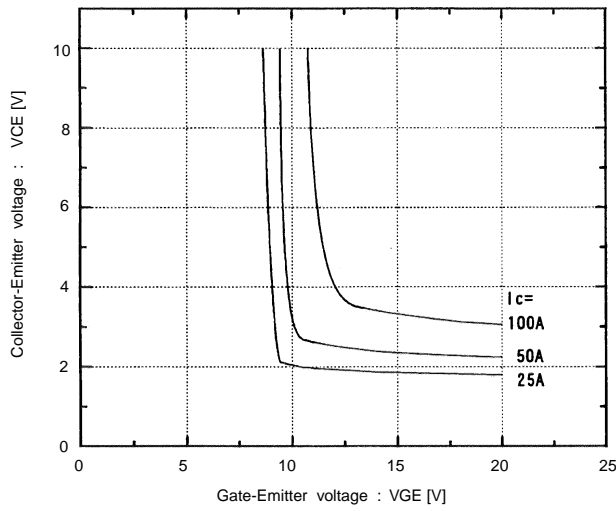

Collector-Emitter vs. Gate-Emitter voltage  
T<sub>j</sub>=125°C

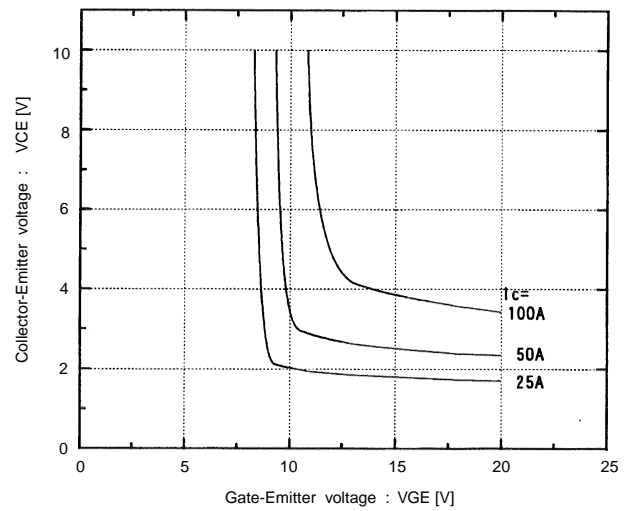

Switching time vs. Collector current  
V<sub>cc</sub>=300V, R<sub>G</sub>=51 ohm, V<sub>GE</sub>=±15V, T<sub>j</sub>=25°C

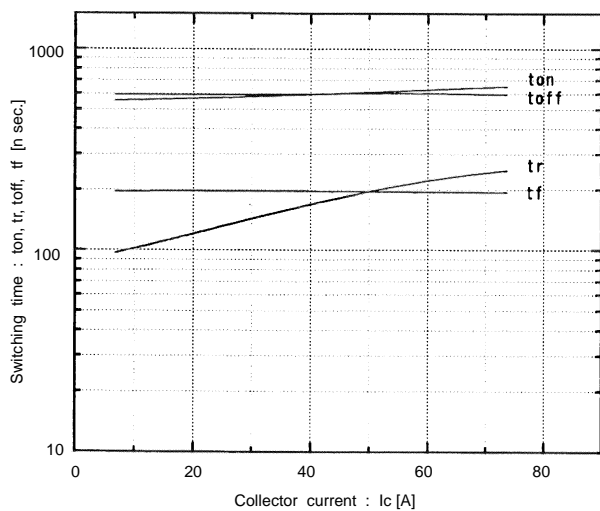

Switching time vs. Collector current  
V<sub>cc</sub>=300V, R<sub>G</sub>=51 ohm, V<sub>GE</sub>=±15V, T<sub>j</sub>=125°C

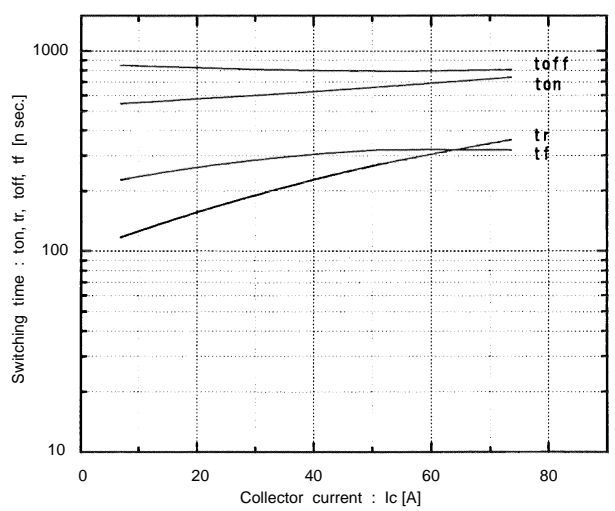

Switching time vs.  $R_G$   
 $V_{CC}=300V, I_c=50A, V_{GE}=\pm 15V, T_J=25^\circ C$

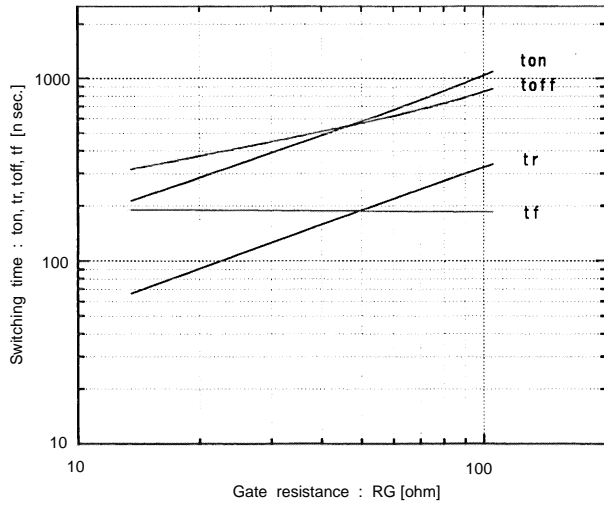

Dynamic input characteristics  
 $T_J=25^\circ C$

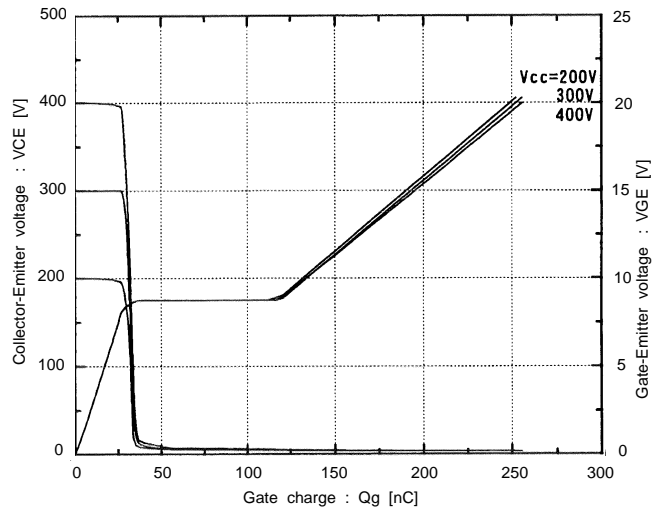

Transient thermal resistance

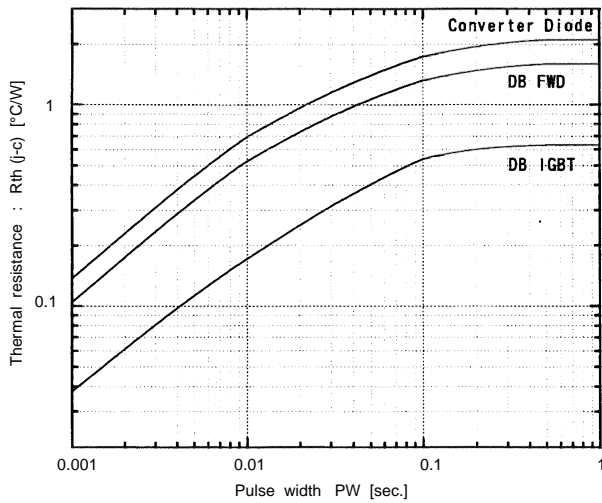

Reversed biased safe operating area  
 $+V_{GE}=15V, -V_{GE} \leq 15V, T_J \leq 125^\circ C, R_G \geq 51 \text{ ohm}$

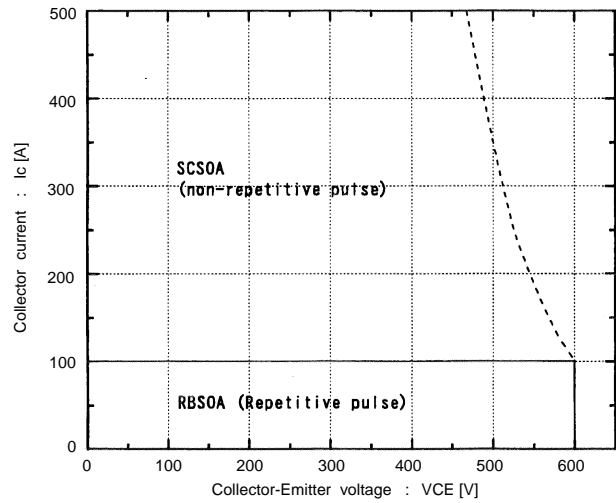

Capacitance vs. Collector-Emitter voltage  
 $T_J=25^\circ C$

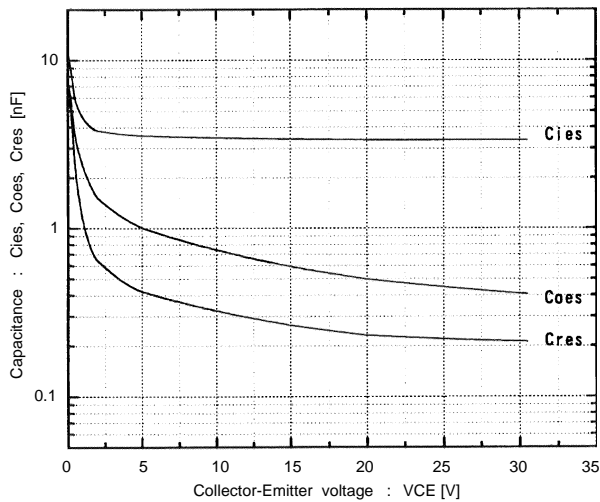

■ Outline Drawings, mm

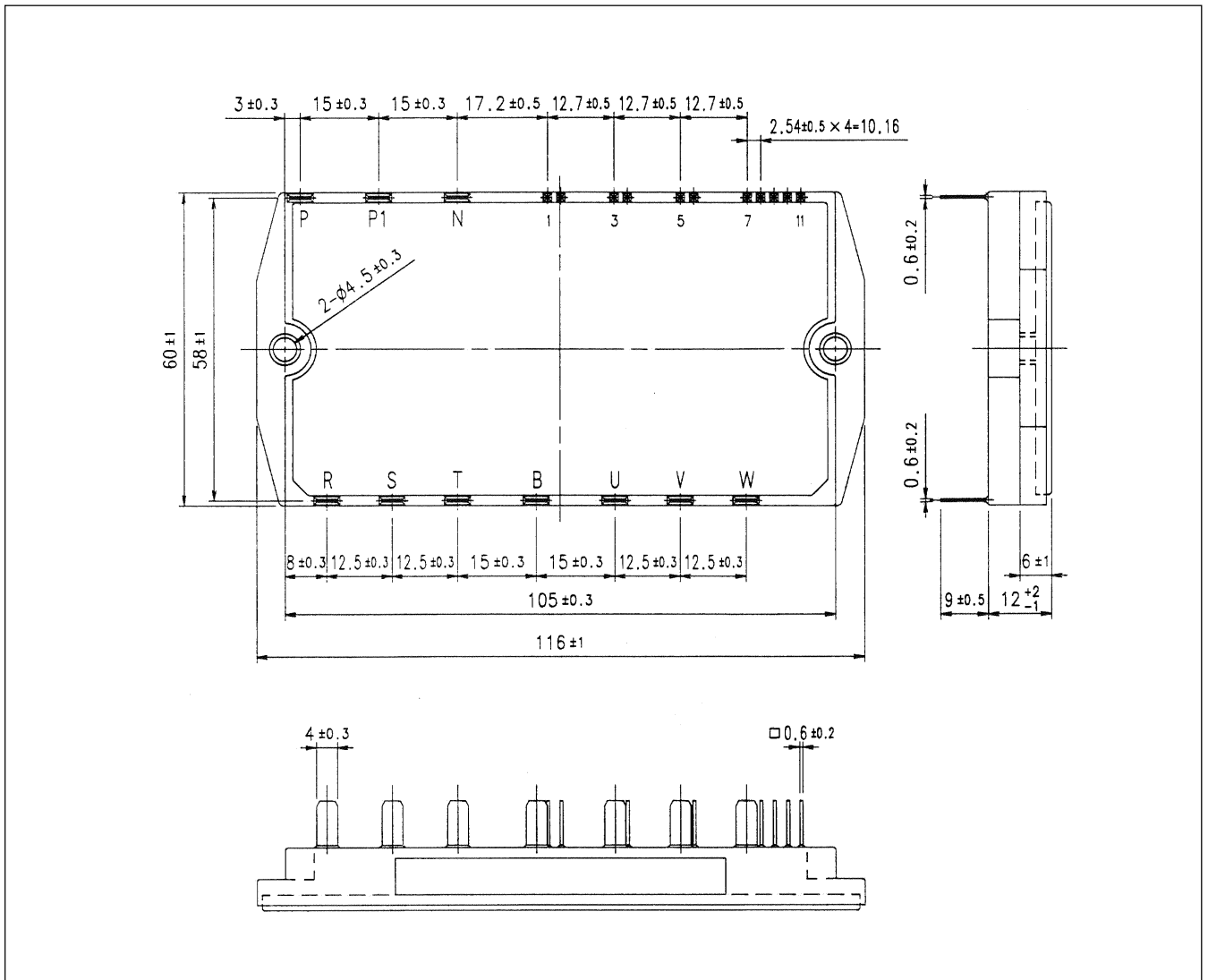



For more information, contact:

**Collmer Semiconductor, Inc.**

P.O. Box 702708

Dallas, TX 75370

972-733-1700

972-381-9991 Fax

<http://www.collmer.com>