



rev 1.3

3.3V 'SpreadTrak' Zero Delay Buffer

Features

- Zero input - output propagation delay, adjustable by capacitive load on FBK input.
- Multiple configurations - Refer "ASM5P23S04A Configurations Table".
- Input frequency range: 15MHz to 133MHz
- Multiple low-skew outputs.
- Output-output skew less than 200pS.
- Device-device skew less than 500pS.
- Two banks of two outputs each.
- Less than 200pS Cycle-to-cycle jitter (-1, -1H, -2, -2H).
- Available in space saving, 8 pin 150-mil SOIC package.
- 3.3V operation.
- Advanced 0.35 μ CMOS technology.
- Industrial temperature available.
- 'SpreadTrak'.

Functional Description

ASM5P23S04A is a versatile, 3.3V zero-delay buffer designed to distribute high-speed clocks in PC, workstation, datacom, telecom and other high-performance applications. It is available in a 8 pin package. The part has an on-chip PLL, which locks to an input clock, presented on

the REF pin. The PLL feedback is required to be driven to FBK pin, and can be obtained from one of the outputs. The input-to-output propagation delay is guaranteed to be less than 250pS, and the output-to-output skew is guaranteed to be less than 200pS.

The ASM5P23S04A has two banks of two outputs each. Multiple ASM5P23S04A devices can accept the same input clock and distribute it. In this case the skew between the outputs of the two devices is guaranteed to be less than 500pS.

The ASM5P23S04A is available in two different configurations (Refer "ASM5P23S04A Configurations Table"). The ASM5P23S04A-1 is the base part, where the output frequencies equal the reference if there is no counter in the feedback path. The ASM5P23S04A-1H is the high-drive version of the -1 and the rise and fall times on this device are much faster.

The ASM5P23S04A-2 allows the user to obtain REF and 1/2X or 2X frequencies on each output bank. The exact configuration and output frequencies depend on which output drives the feedback pin.

Block Diagram

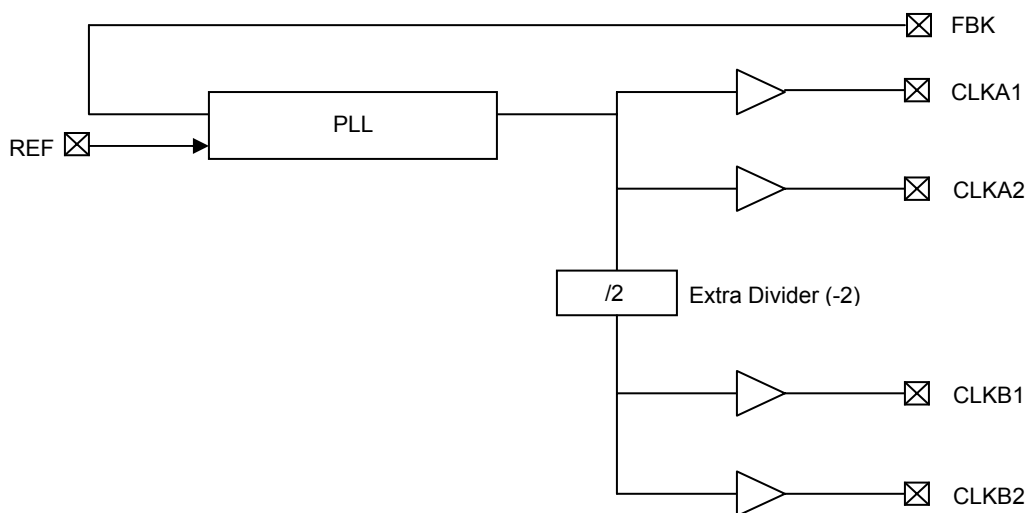



rev 1.3

ASM5P23S04A Configurations

Device	Feedback From	Bank A Frequency	Bank B Frequency
ASM5P23S04A-1	Bank A or Bank B	Reference	Reference
ASM5P23S04A-1H	Bank A or Bank B	Reference	Reference
ASM5P23S04A-2	Bank A	Reference	Reference /2
ASM5P23S04A-2	Bank B	2 X Reference	Reference
ASM5P23S04A-2H	Bank A	Reference	Reference/2
ASM5P23S04A-2H	Bank B	2 X Reference	Reference

‘SpreadTrak’

Many systems being designed now utilize a technology called Spread Spectrum Frequency Timing Generation. ASM5P23S04A is designed so as not to filter off the Spread Spectrum feature of the Reference Input,

assuming it exists. When a zero delay buffer is not designed to pass the Spread Spectrum feature through, the result is a significant amount of tracking skew which may cause problems in the systems requiring synchronization.

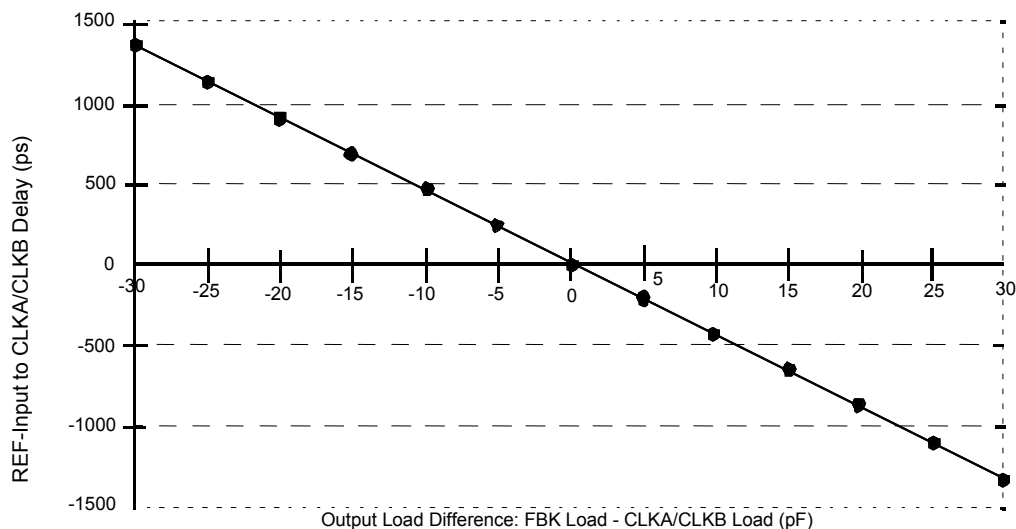

REF Input to CLKA/CLKB Delay Vs Difference in Loading between FBK pin and CLKA/CLKB pins



rev 1.3

Zero Delay and Skew Control

For applications requiring zero input-output delay, all outputs must be equally loaded. To close the feedback loop of ASM5P23S04A, the FBK pin can be driven from any of the four available output pins. The output driving the FBK pin will be driving a total load of 7pF plus any additional load that it drives. The relative loading of this output (with respect to the remaining outputs) can adjust the input

output delay. This is shown in the above graph. For applications requiring zero input-output delay, all outputs including the one providing feedback should be equally loaded. If input-output delay adjustments are required, use the above graph to calculate loading differences between the feedback output and remaining outputs. For zero output-output skew, be sure to load outputs equally.

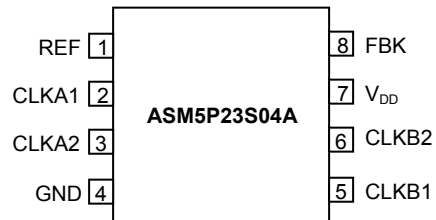
Pin Configuration**Pin Description for ASM5P23S04A**

Pin #	Pin Name	Description
1	REF ¹	Input reference frequency, 5V tolerant input
2	CLKA1 ²	Buffered clock output, bank A
3	CLKA2 ²	Buffered clock output, bank A
4	GND	Ground
5	CLKB1 ²	Buffered clock output, bank B
6	CLKB2 ²	Buffered clock output, bank B
7	V _{DD}	3.3V supply
8	FBK	PLL feedback input

Notes:

1. Weak pull-down.
2. Weak pull-down on all outputs.



rev 1.3

Absolute Maximum Ratings

Parameter	Min	Max	Unit
Supply Voltage to Ground Potential	-0.5	+7.0	V
DC Input Voltage (Except REF)	-0.5	$V_{DD} + 0.5$	V
DC Input Voltage (REF)	-0.5	7	V
Storage Temperature	-65	+150	°C
Max. Soldering Temperature (10 sec)		260	°C
Junction Temperature		150	°C
Static Discharge Voltage (As per JEDEC STD22- A114-B)		>2000	V
Note: These are stress ratings only and functional usage is not implied. Exposure to absolute maximum ratings for prolonged periods can affect device reliability.			

Operating Conditions for ASM5P23S04A Commercial Temperature Devices

Parameter	Description	Min	Max	Unit
V_{DD}	Supply Voltage	3.0	3.6	V
T_A	Operating Temperature (Ambient Temperature)	0	70	°C
C_L	Load Capacitance, below 100MHz		30	pF
C_L	Load Capacitance, from 100MHz to 133MHz		15	pF
C_{IN}	Input Capacitance ³		7	pF

Note:

3. Applies to both Ref Clock and FBK.



rev 1.3

Electrical Characteristics for ASM5P23S04A Commercial Temperature Devices

Parameter	Description	Test Conditions	Min	Max	Unit
V_{IL}	Input LOW Voltage			0.8	V
V_{IH}	Input HIGH Voltage		2.0		V
I_{IL}	Input LOW Current	$V_{IN} = 0V$		50.0	μA
I_{IH}	Input HIGH Current	$V_{IN} = V_{DD}$		100.0	μA
V_{OL}	Output LOW Voltage ⁴	$I_{OL} = 8mA$ (-1, -2) $I_{OH} = 12mA$ (-1H, -2H)		0.4	V
V_{OH}	Output HIGH Voltage ⁴	$I_{OL} = -8mA$ (-1, -2) $I_{OH} = -12mA$ (-1H, -2H)	2.4		V
I_{DD}	Supply Current	Unloaded outputs 100MHz REF, Select inputs at V_{DD} or GND		45.0	mA
		Unloaded outputs, 66MHz REF (-1, -2)		32.0	
		Unloaded outputs, 33MHz REF (-1, -2)		18.0	

Note:

4. Parameter is guaranteed by design and characterization. Not 100% tested in production.



rev 1.3

Switching Characteristics for ASM5P23S04A Commercial Temperature Devices

Parameter	Description	Test Conditions	Min	Typ	Max	Unit
1/t ₁	Output Frequency	30pF load, All devices	15		100	MHz
1/t ₁	Output Frequency	15pF load, -1H, -2H devices	15		133	MHz
1/t ₁	Output Frequency	15pF load, -1, -2 devices	15		133	MHz
	Duty Cycle ⁵ = (t ₂ / t ₁) * 100 (-1, -2, -1H, -2H)	Measured at 1.4V, F _{OUT} = 66.66MHz 30pF load	40.0	50.0	60.0	%
	Duty Cycle ⁵ = (t ₂ / t ₁) * 100 (-1, -2, -1H, -2H)	Measured at 1.4V, F _{OUT} = <50MHz 15 pF load	45.0	50.0	55.0	%
t ₃	Output Rise Time ⁵ (-1, -2)	Measured between 0.8V and 2.0V 30pF load			2.20	nS
t ₃	Output Rise Time ⁵ (-1, -2)	Measured between 0.8V and 2.0V 15pF load			1.50	nS
t ₃	Output Rise Time ⁵ (-1H, -2H)	Measured between 0.8V and 2.0V 30pF load			1.50	nS
t ₄	Output Fall Time ⁵ (-1, -2)	Measured between 2.0V and 0.8V 30pF load			2.20	nS
t ₄	Output Fall Time ⁵ (-1, -2)	Measured between 2.0V and 0.8V 15pF load			1.50	nS
t ₄	Output Fall Time ⁵ (-1H, -2H)	Measured between 2.0V and 0.8V 30pF load			1.25	nS
t ₅	Output-to-output skew on same bank (-1, -2) ⁵	All outputs equally loaded			200	pS
	Output-to-output skew (-1H, -2H)	All outputs equally loaded			200	
	Output bank A -to- output bank B skew (-1, -2H)	All outputs equally loaded			200	
	Output bank A to output bank B skew (-2)	All outputs equally loaded			400	
t ₆	Delay, REF Rising Edge to FBK Rising Edge ⁵	Measured at V _{DD} /2		0	±250	pS
t ₇	Device-to-Device Skew ⁵	Measured at V _{DD} /2 on the FBK pins of the device		0	500	pS
t ₈	Output Slew Rate ⁵	Measured between 0.8V and 2.0V using Test Circuit #2	1			V/nS
t _J	Cycle-to-cycle jitter ⁵ (-1, -1H, -2H)	Measured at 66.67MHz, loaded outputs, 15pF load			175	pS
		Measured at 66.67MHz, loaded outputs, 30pF load			200	
		Measured at 133MHz, loaded outputs, 15pF load			100	
t _J	Cycle-to-cycle jitter ⁵ (-2)	Measured at 66.67MHz, loaded outputs, 30pF load			400	pS
		Measured at 66.67MHz, loaded outputs, 15pF load			375	
t _{LOCK}	PLL Lock Time ⁵	Stable power supply, valid clock presented on REF and FBK pins			1.0	mS

Note:

5. Parameter is guaranteed by design and characterization. Not 100% tested in production.



rev 1.3

Operating Conditions for ASM5I23S04A Industrial Temperature Devices

Parameter	Description	Min	Max	Unit
V_{DD}	Supply Voltage	3.0	3.6	V
T_A	Operating Temperature (Ambient Temperature)	-40	85	°C
C_L	Load Capacitance, below 100MHz		30	pF
C_L	Load Capacitance, from 100MHz to 133MHz		15	pF
C_{IN}	Input Capacitance ⁶		7	pF

Note:

6. Applies to both Ref Clock and FBK.

Electrical Characteristics for ASM5I23S04A Industrial Temperature Devices

Parameter	Description	Test Conditions	Min	Max	Unit
V_{IL}	Input LOW Voltage			0.8	V
V_{IH}	Input HIGH Voltage		2.0		V
I_{IL}	Input LOW Current	$V_{IN} = 0V$		50.0	μA
I_{IH}	Input HIGH Current	$V_{IN} = V_{DD}$		100.0	μA
V_{OL}	Output LOW Voltage ⁷	$I_{OL} = 8mA$ (-1, -2) $I_{OH} = 12mA$ (-1H, -2H)		0.4	V
V_{OH}	Output HIGH Voltage ⁷	$I_{OL} = -8mA$ (-1, -2) $I_{OH} = -12mA$ (-1H, -2H)	2.4		V
I_{DD}	Supply Current	Unloaded outputs 100MHz REF, Select inputs at V_{DD} or GND		45.0	mA
		Unloaded outputs, 66MHz REF (-1, -2)		35.0	
		Unloaded outputs, 33MHz REF (-1, -2)		20.0	

Note:

7. Parameter is guaranteed by design and characterization. Not 100% tested in production.



rev 1.3

Switching Characteristics for ASM5I23S04A Industrial Temperature Devices

Parameter	Description	Test Conditions	Min	Typ	Max	Unit
t ₁	Output Frequency	30pF load, All devices	15		100	MHz
t ₁	Output Frequency	15pF load, -1H, -2H devices	15		133	MHz
t ₁	Output Frequency	15pF load, -1 and -2 devices	15		133	MHz
	Duty Cycle ⁸ = (t ₂ / t ₁) * 100 (-1, -2, -1H, -2H)	Measured at 1.4V, F _{OUT} = <66.66MHz 30pF load	40.0	50.0	60.0	%
	Duty Cycle ⁸ = (t ₂ / t ₁) * 100 (-1, -2, -1H, -2H)	Measured at 1.4V, F _{OUT} = <50MHz 15pF load	45.0	50.0	55.0	%
t ₃	Output Rise Time ⁸ (-1, -2)	Measured between 0.8V and 2.0V 30pF load			2.50	nS
t ₃	Output Rise Time ⁸ (-1, -2)	Measured between 0.8V and 2.0V 15pF load			1.50	nS
t ₃	Output Rise Time ⁸ (-1H, -2H)	Measured between 0.8V and 2.0V 30pF load			1.50	nS
t ₄	Output Fall Time ⁸ (-1, -2)	Measured between 2.0V and 0.8V 30pF load			2.50	nS
t ₄	Output Fall Time ⁸ (-1, -2)	Measured between 2.0V and 0.8V 15pF load			1.50	nS
t ₄	Output Fall Time ⁸ (-1H, -2H)	Measured between 2.0V and 0.8V 30pF load			1.25	nS
t ₅	Output-to-output skew on same bank (-1, -2) ⁸	All outputs equally loaded			200	pS
	Output-to-output skew (-1H, -2H)	All outputs equally loaded			200	
	Output bank A to- output bank B skew (-1, -2H)	All outputs equally loaded			200	
	Output bank A to- output bank B skew (-2)	All outputs equally loaded			400	
t ₆	Delay, REF Rising Edge to FBK Rising Edge ⁸	Measured at V _{DD} /2		0	±250	pS
t ₇	Device-to-Device Skew ⁸	Measured at V _{DD} /2 on the FBK pins of the device		0	500	pS
t ₈	Output Slew Rate ⁸	Measured between 0.8V and 2.0V using Test Circuit #2	1			V/nS
t _J	Cycle-to-cycle jitter ⁸ (-1, -1H, -2H)	Measured at 66.67MHz, loaded outputs, 15pF load			180	pS
		Measured at 66.67MHz, loaded outputs, 30pF load			200	
		Measured at 133MHz, loaded outputs, 15pF load			100	
t _J	Cycle-to-cycle jitter ⁸ (-2)	Measured at 66.67MHz, loaded outputs, 30pF load			400	pS
		Measured at 66.67 MHz, loaded outputs, 15pF load			380	
t _{LOCK}	PLL Lock Time ⁸	Stable power supply, valid clock presented on REF and FBK pins			1.0	mS

Note: 8. Parameter is guaranteed by design and characterization. Not 100% tested in production.



rev 1.3

Switching Waveforms

Duty Cycle Timing

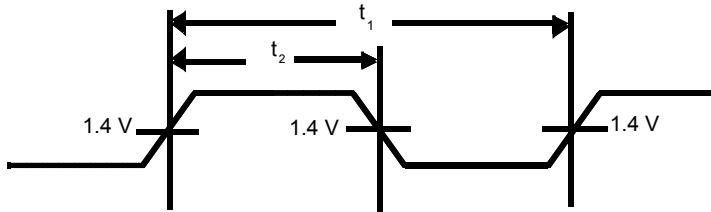

All Outputs Rise/Fall Time

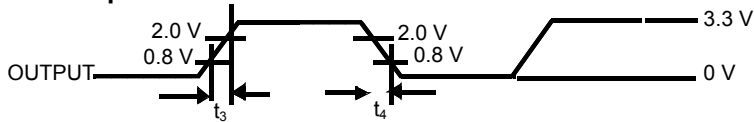

Output - Output Skew

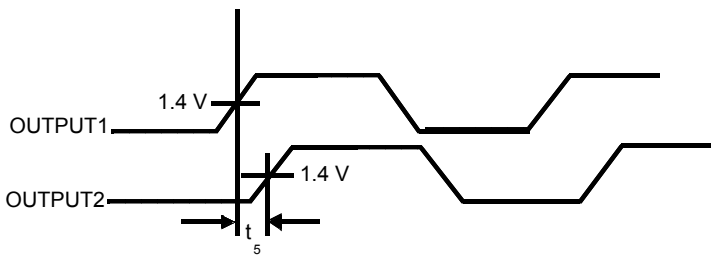

Input - Output Propagation Delay

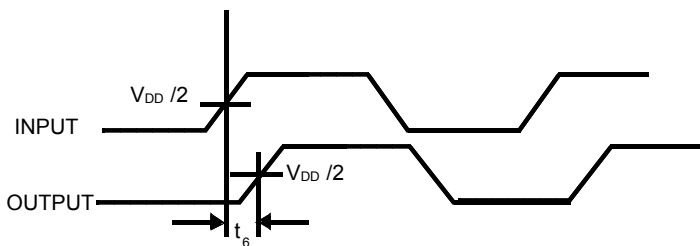

Device - Device Skew

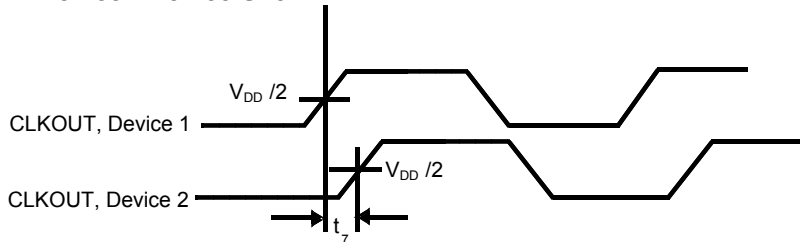



rev 1.3

Test Circuits

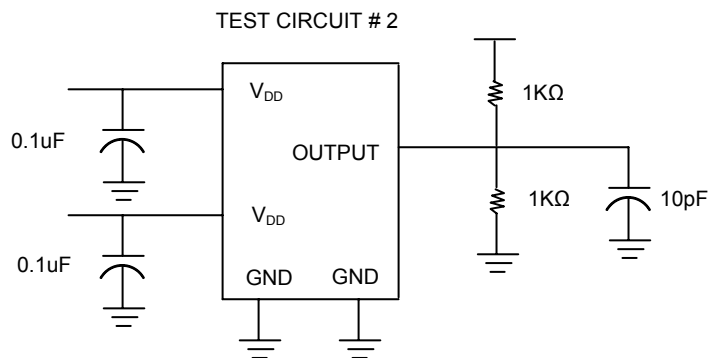
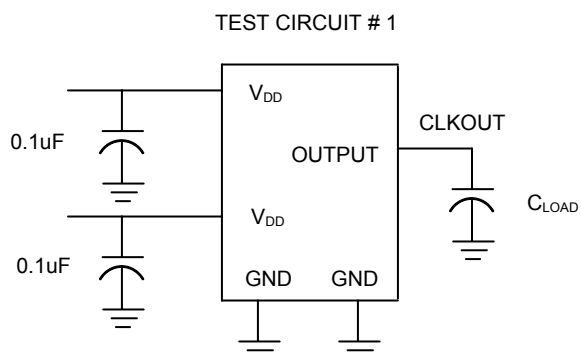

For parameter t_s (output skew rate)



rev 1.3

Package Information

8-lead (150-mil) SOIC Package

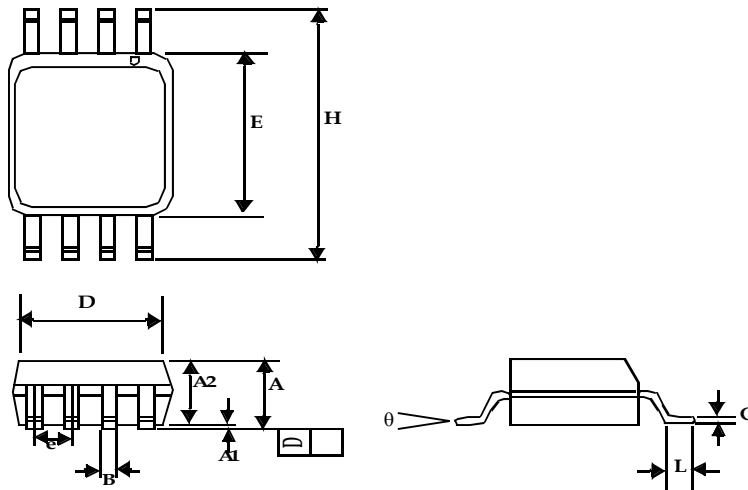

Symbol	Dimensions			
	Inches		Millimeters	
	Min	Max	Min	Max
A1	0.004	0.010	0.10	0.25
A	0.053	0.069	1.35	1.75
A2	0.049	0.059	1.25	1.50
B	0.012	0.020	0.31	0.51
C	0.007	0.010	0.18	0.25
D	0.193 BSC		4.90 BSC	
E	0.154 BSC		3.91 BSC	
e	0.050 BSC		1.27 BSC	
H	0.236 BSC		6.00 BSC	
L	0.016	0.050	0.41	1.27
θ	0°	8°	0°	8°



rev 1.3

Ordering Codes

Ordering Code	Marking	Package Type	Operating Range
ASM5P23S04A-1-08-SR	5P23S04A-1	8-pin 150-mil SOIC-TAPE & REEL	Commercial
ASM5P23S04A-1-08-ST	5P23S04A-1	8-pin 150-mil SOIC-TUBE	Commercial
ASM5I23S04A-1-08-SR	5I23S04A-1	8-pin 150-mil SOIC-TAPE & REEL	Industrial
ASM5I23S04A-1-08-ST	5I23S04A-1	8-pin 150-mil SOIC-TUBE	Industrial
ASM5P23S04A-1H-08-SR	5P23S04A-1H	8-pin 150-mil SOIC-TAPE & REEL	Commercial
ASM5P23S04A-1H-08-ST	5P23S04A-1H	8-pin 150-mil SOIC-TUBE	Commercial
ASM5I23S04A-1H-08-SR	5I23S04A-1H	8-pin 150-mil SOIC-TAPE & REEL	Industrial
ASM5I23S04A-1H-08-ST	5I23S04A-1H	8-pin 150-mil SOIC-TUBE	Industrial
ASM5P23S04A-2-08-SR	5P23S04A-2	8-pin 150-mil SOIC-TAPE & REEL	Commercial
ASM5P23S04A-2-08-ST	5P23S04A-2	8-pin 150-mil SOIC-TUBE	Commercial
ASM5I23S04A-2-08-SR	5I23S04A-2	8-pin 150-mil SOIC-TAPE & REEL	Industrial
ASM5I23S04A-2-08-ST	5I23S04A-2	8-pin 150-mil SOIC-TUBE	Industrial
ASM5P23S04A-2H-08-SR	5P23S04A-2H	8-pin 150-mil SOIC-TAPE & REEL	Commercial
ASM5P23S04A-2H-08-ST	5P23S04A-2H	8-pin 150-mil SOIC-TUBE	Commercial
ASM5I23S04A-2H-08-SR	5I23S04A-2H	8-pin 150-mil SOIC-TAPE & REEL	Industrial
ASM5I23S04A-2H-08-ST	5I23S04A-2H	8-pin 150-mil SOIC-TUBE	Industrial
ASM5P23S04AF-1-08-SR	5P23S04AF-1	8-pin 150-mil SOIC-TAPE & REEL, Pb free	Commercial
ASM5P23S04AF-1-08-ST	5P23S04AF-1	8-pin 150-mil SOIC-TUBE, Pb free	Commercial
ASM5I23S04AF-1-08-SR	5I23S04AF-1	8-pin 150-mil SOIC-TAPE & REEL, Pb free	Industrial
ASM5I23S04AF-1-08-ST	5I23S04AF-1	8-pin 150-mil SOIC-TUBE, Pb free	Industrial



rev 1.3

Ordering Codes (cont'd)

Ordering Code	Marking	Package Type	Operating Range
ASM5P23S04AF-1H-08-SR	5P23S04AF-1H	8-pin 150-mil SOIC-TAPE & REEL, Pb free	Commercial
ASM5P23S04AF-1H-08-ST	5P23S04AF-1H	8-pin 150-mil SOIC-TUBE, Pb free	Commercial
ASM5I23S04AF-1H-08-SR	5I23S04AF-1H	8-pin 150-mil SOIC-TAPE & REEL, Pb free	Industrial
ASM5I23S04AF-1H-08-ST	5I23S04AF-1H	8-pin 150-mil SOIC-TUBE, Pb free	Industrial
ASM5P23S04AF-2-08-SR	5P23S04AF-2	8-pin 150-mil SOIC-TAPE & REEL, Pb free	Commercial
ASM5P23S04AF-2-08-ST	5P23S04AF-2	8-pin 150-mil SOIC-TUBE, Pb free	Commercial
ASM5I23S04AF-2-08-SR	5I23S04AF-2	8-pin 150-mil SOIC-TAPE & REEL, Pb free	Industrial
ASM5I23S04AF-2-08-ST	5I23S04AF-2	8-pin 150-mil SOIC-TUBE, Pb free	Industrial
ASM5P23S04AF-2H-08-SR	5P23S04AF-2H	8-pin 150-mil SOIC-TAPE & REEL, Pb free	Commercial
ASM5P23S04AF-2H-08-ST	5P23S04AF-2H	8-pin 150-mil SOIC-TUBE, Pb free	Commercial
ASM5I23S04AF-2H-08-SR	5I23S04AF2H	8-pin 150-mil SOIC-TAPE & REEL, Pb free	Industrial
ASM5I23S04AF-2H-08-ST	5I23S04AFH	8-pin 150-mil SOIC-TUBE, Pb free	Industrial
ASM5P23S04AG-1-08-SR	5P23S04AG-1	8-pin 150-mil SOIC-TAPE & REEL, Green	Commercial
ASM5P23S04AG-1-08-ST	5P23S04AG-1	8-pin 150-mil SOIC-TUBE, Green	Commercial
ASM5I23S04AG-1-08-SR	5I23S04AG-1	8-pin 150-mil SOIC-TAPE & REEL, Green	Industrial
ASM5I23S04AG-1-08-ST	5I23S04AG-1	8-pin 150-mil SOIC-TUBE, Green	Industrial
ASM5P23S04AG-1H-08-SR	5P23S04AG-1H	8-pin 150-mil SOIC-TAPE & REEL, Green	Commercial
ASM5P23S04AG-1H-08-ST	5P23S04AG-1H	8-pin 150-mil SOIC-TUBE, Green	Commercial
ASM5I23S04AG-1H-08-SR	5I23S04AG-1H	8-pin 150-mil SOIC-TAPE & REEL, Green	Industrial
ASM5I23S04AG-1H-08-ST	5I23S04AG-1H	8-pin 150-mil SOIC-TUBE, Green	Industrial



rev 1.3

Ordering Codes (cont'd)

Ordering Code	Marking	Package Type	Operating Range
ASM5P23S04AG-2-08-SR	5P23S04AG-2	8-pin 150-mil SOIC-TAPE & REEL, Green	Commercial
ASM5P23S04AG-2-08-ST	5P23S04AG-2	8-pin 150-mil SOIC-TUBE, Green	Commercial
ASM5I23S04AG-2-08-SR	5I23S04AG-2	8-pin 150-mil SOIC-TAPE & REEL, Green	Industrial
ASM5I23S04AG-2-08-ST	5I23S04AG-2	8-pin 150-mil SOIC-TUBE, Green	Industrial
ASM5P23S04AG-2H-08-SR	5P23S04AG-2H	8-pin 150-mil SOIC-TAPE & REEL, Green	Commercial
ASM5P23S04AG-2H-08-ST	5P23S04AG-2H	8-pin 150-mil SOIC-TUBE, Green	Commercial
ASM5I23S04AG-2H-08-SR	5I23S04AG-2H	8-pin 150-mil SOIC-TAPE & REEL, Green	Industrial
ASM5I23S04AG-2H-08-ST	5I23S04AG-2H	8-pin 150-mil SOIC-TUBE, Green	Industrial

Device Ordering Information

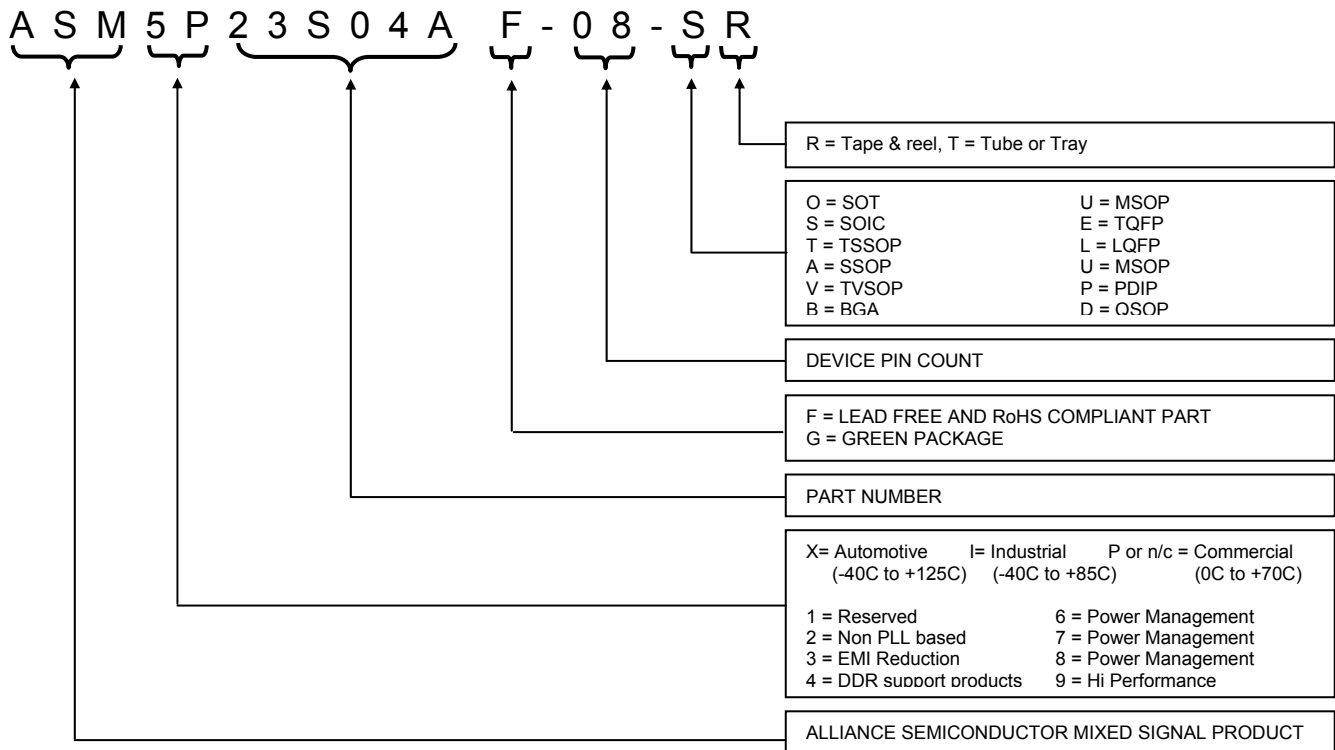

Licensed under US patent #5,488,627, #6,646,463 and #5,631,920.



Alliance Semiconductor Corporation
2575 Augustine Drive,
Santa Clara, CA 95054
Tel# 408-855-4900
Fax: 408-855-4999
www.alsc.com

Copyright © Alliance Semiconductor
All Rights Reserved
Part Number: ASM5P23S04A
Document Version: 1.3

Note: This product utilizes US# 6,646,463 Impedance Emulator Patent issued to Alliance Semiconductor, dated 11-11-2003

© Copyright 2003 Alliance Semiconductor Corporation. All rights reserved. Our three-point logo, our name and Intelliwatt are trademarks or registered trademarks of Alliance. All other brand and product names may be the trademarks of their respective companies. Alliance reserves the right to make changes to this document and its products at any time without notice. Alliance assumes no responsibility for any errors that may appear in this document. The data contained herein represents Alliance's best data and/or estimates at the time of issuance. Alliance reserves the right to change or correct this data at any time, without notice. If the product described herein is under development, significant changes to these specifications are possible. The information in this product data sheet is intended to be general descriptive information for potential customers and users, and is not intended to operate as, or provide, any guarantee or warranty to any user or customer. Alliance does not assume any responsibility or liability arising out of the application or use of any product described herein, and disclaims any express or implied warranties related to the sale and/or use of Alliance products including liability or warranties related to fitness for a particular purpose, merchantability, or infringement of any intellectual property rights, except as express agreed to in Alliance's Terms and Conditions of Sale (which are available from Alliance). All sales of Alliance products are made exclusively according to Alliance's Terms and Conditions of Sale. The purchase of products from Alliance does not convey a license under any patent rights, copyrights; mask works rights, trademarks, or any other intellectual property rights of Alliance or third parties. Alliance does not authorize its products for use as critical components in life-supporting systems where a malfunction or failure may reasonably be expected to result in significant injury to the user, and the inclusion of Alliance products in such life-supporting systems implies that the manufacturer assumes all risk of such use and agrees to indemnify Alliance against all claims arising from such use.