

3.3 V TEMPERATURE COMPENSATED CRYSTAL OSCILLATOR

ASTX-01HA



RoHS
Compliant



11.4 x 9.6 x 4.0 mm

FEATURES:

- SMD package makes reflow soldering possible
- TTL / HCMOS

APPLICATIONS:

- Standard OSC for exact equipment
- Portable radio equipment
- Car telephone
- Base clock

STANDARD SPECIFICATIONS:

PARAMETERS

ABRACON P/N	ASTX-01HA
Frequency Range	2.000MHz to 30.000MHz
Operating Temperature	-30°C to + 75°C (see options below)
Storage Temperature	- 40°C to + 85°C
Frequency stability vs. Temperature vs. Supply Voltage vs. Load vs. Aging vs. Initial Tolerance	±2.5 ppm (see options below) ±0.3 ppm max./ Vdd ±5% ±0.3 ppm max./ Load ±10% ±1 ppm/yr max. ±0.5 ppm at +25°C
Frequency adjustment (Internal Trimmer)	±3.0ppm
Supply voltage (V _{DD})	3.3 Vdc ± 5%
Supply current (I _{CC})	15mA max.
Output Level (V _{OH})	0.9*Vdd min.
Output Level (V _{OL})	0.1*Vdd min.
Output Load	10TTL or 15pF
Output wave form	TTL/HCMOS
Jitter (pk-pk)	40ps max.
Phase noise	-120dBc/Hz @ 100Hz -140dBc/Hz @ 1KHz -145dBc/Hz @ 10KHz -150dBc/Hz @ 100KHz
Start-up time:	10ms max.

OPTIONS & PART IDENTIFICATION:

(Left blank if standard)

ASTX - 01HA - Frequency - □ - □

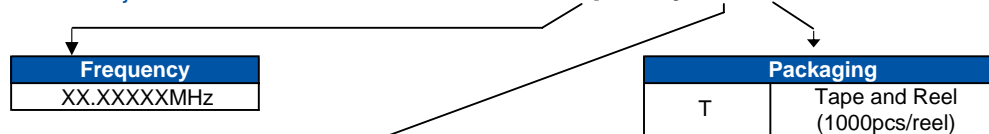

Temperature & Frequency Stability

Temp. Range	±1.5ppm	±2.0ppm	±2.5 ppm	±3.0 ppm	±3.5 ppm	±4.0 ppm	±4.5 ppm	±5.0 ppm
0°C to +50°C	I15	I20	I25	I30	I35	I40	I45	I50
-10°C to +60°C	D15	D20	D25	D30	D35	D40	D45	D50
-10°C to +70°C		C20	C25	C30	C35	C40	C45	C50
-20°C to +70°C		E20	E25	E30	E35	E40	E45	E50
-30°C to +60°C			H25	H30	H35	H40	H45	H50
-30°C to +70°C			F25	F30	F35	F40	F45	F50
-30°C to +75°C			STD	N30	N35	N40	N45	N50
-40°C to +80°C					M35	M40	M45	M50
-40°C to +85°C					L35	L40	L45	L50

ABRACON IS
ISO 9001 / QS 9000
CERTIFIED



ABRACON
CORPORATION

Visit www.abracon.com for Terms & Conditions of Sale **Revised: 07.03.07**

30332 Esperanza, Rancho Santa Margarita, California 92688

tel 949-546-8000 | fax 949-546-8001 | www.abracon.com

3.3 V TEMPERATURE COMPENSATED CRYSTAL OSCILLATOR

ASTX-01HA



RoHS
Compliant



11.4 x 9.6 x 4.0 mm

OUTLINE DRAWING:

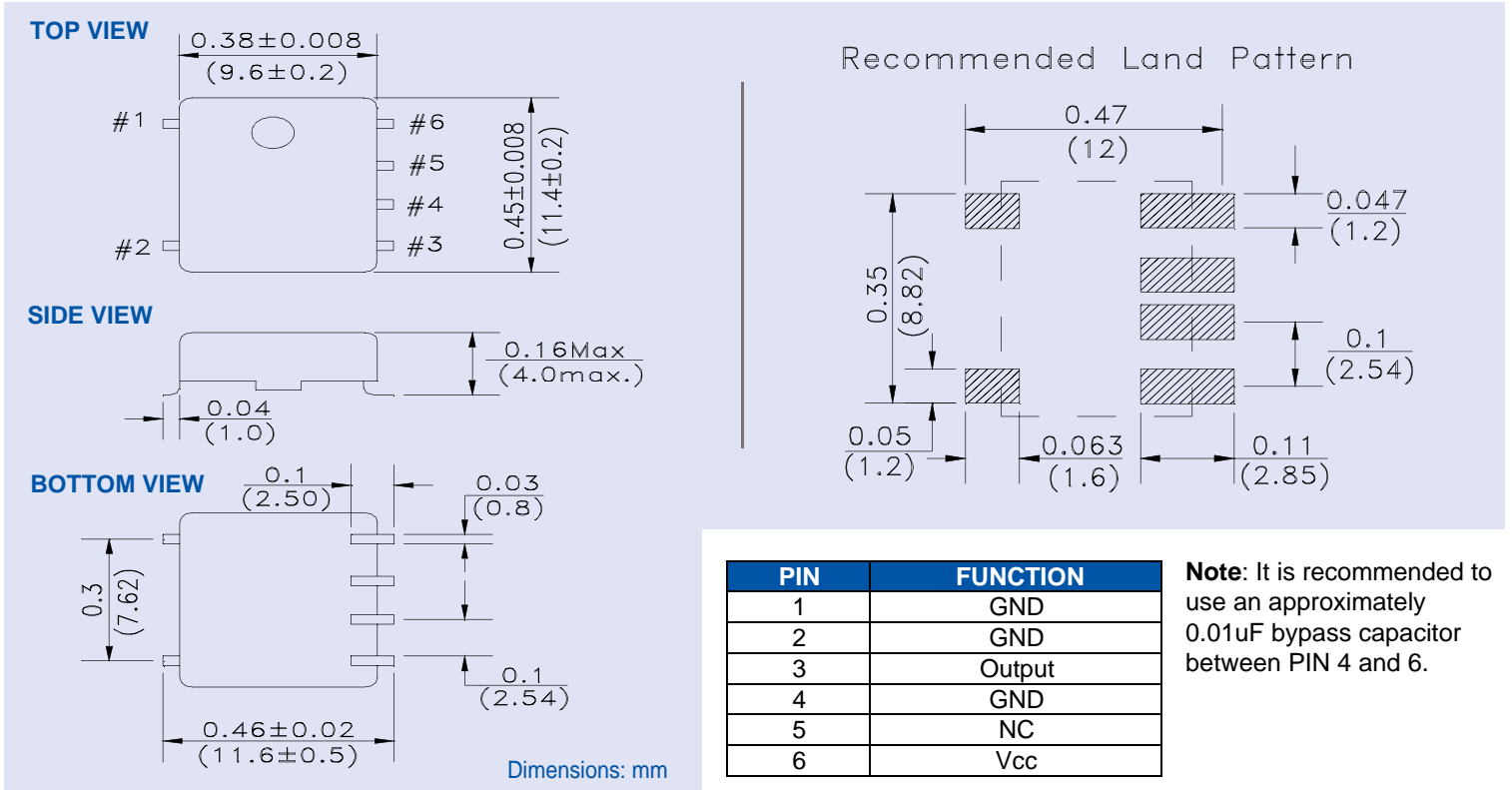

TAPE & REEL: T = Tape and reel 1,000pcs/reel

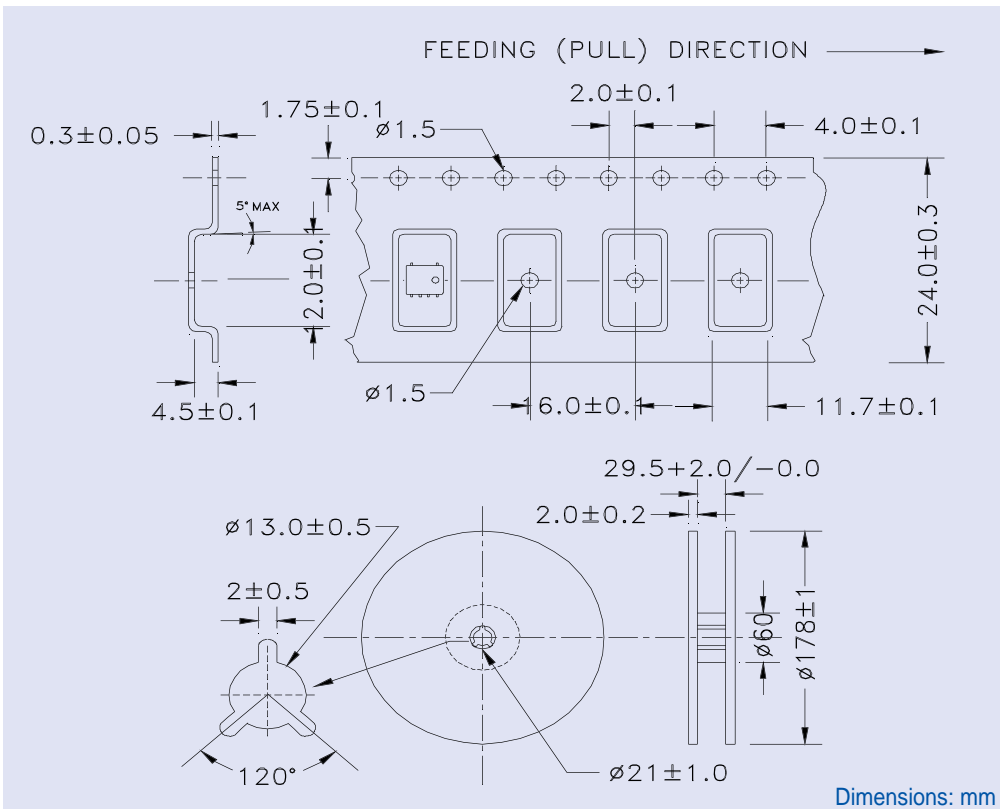

ABRACON IS
ISO 9001 / QS 9000
CERTIFIED



Visit www.abracon.com for Terms & Conditions of Sale **Revised: 07.11.07**

30332 Esperanza, Rancho Santa Margarita, California 92688

tel 949-546-8000 | fax 949-546-8001 | www.abracon.com