

# B 40S ... B 500S

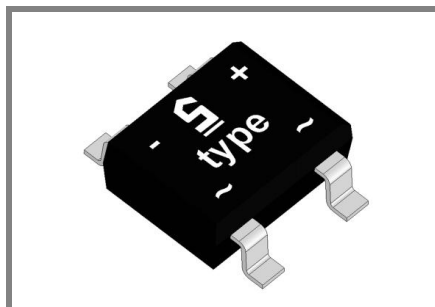

Square bridge

Type	Alternating Input voltage $V_{VRMS}$ V	Repetitive peak reverse voltage $V_{RRM}$ V	Max. admissible load capacitor $C_L$ $\mu F$	Min. required protective resistor $R_t$ $\Omega$
B 40S	40	80	5000	0,8
B 80S	80	160	2500	1,6
B 125S	125	250	1500	2,5
B 250S	250	600	800	5
B 380S	380	800	600	8
B 500S	500	1000	400	10

## Surface Mount Si-Bridge Rectifiers

B 40S ... B 500S

Forward Current: 1,0 A

Reverse Voltage: 80 to 1000 V

Publish Data

### Features

- max. solder temperature 260°C, max. 5s
- UL recognized, file no. E63532
- Standard packaging taped and reeled

### Mechanical Data

- Plastic case 8,3 \* 6,4 \* 3,1 [mm]
- Weight approx. 0,3 g
- Terminals: plated terminals solderable per IEC68-2-20
- Mounting position: any

**Absolute Maximum Ratings**  $T_c = 25^\circ C$  unless otherwise specified

Symbol	Conditions	Values	Units
$I^2t$	Rating for fusing, $t < 10$ ms	8	A <sup>2</sup> s
$I_{FRM}$	Repetitive peak forward current > 15 Hz	10	A
$I_{FSM}$	Peak forward surge current, 50 Hz half sine-wave	40	A
$t_{rr}$	Reverse recovery time ( $I_F = A$ )		ns
$I_{FAV}$	Max. averaged fwd. current, R-load, $T_A = 50^\circ C$ <sup>1)</sup>	1	A
$I_{FAV}$	Max. averaged fwd. current, C-load, $T_A = 50^\circ C$ <sup>1)</sup>	0,8	A
$I_{FAV}$	Max. current with cooling fin, R-load, $T_c = ^\circ C$ <sup>2)</sup>	/	A
$I_{FAV}$	Max. current with cooling fin, C-load, $T_c = ^\circ C$ <sup>2)</sup>	/	A
$R_{thA}$	Thermal resistance junction to ambient <sup>1)</sup>	60	K/W
$R_{thC}$	Thermal resistance junction to case <sup>1)</sup>		K/W
$T_j$	Operating junction temperature	- 50 ... + 150	°C
$T_s$	Storage temperature	- 50 ... + 150	°C

**Characteristics**  $T_c = 25^\circ C$  unless otherwise specified

Symbol	Conditions	Values	Units
$V_F$	Maximum forward voltage, $T_j = 25^\circ C$ , $I_F = 1$ A	1,1	V
$I_R$	Maximum leakage current, $T_j = 25^\circ C$ , $V_R = V_{RRM}$	10	$\mu A$
$C_j$	Typical junction capacitance per leg at V, MHz		pF

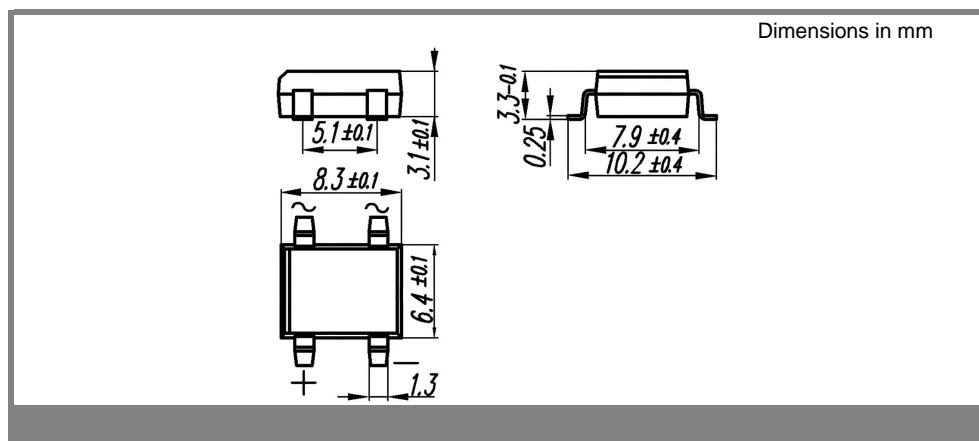

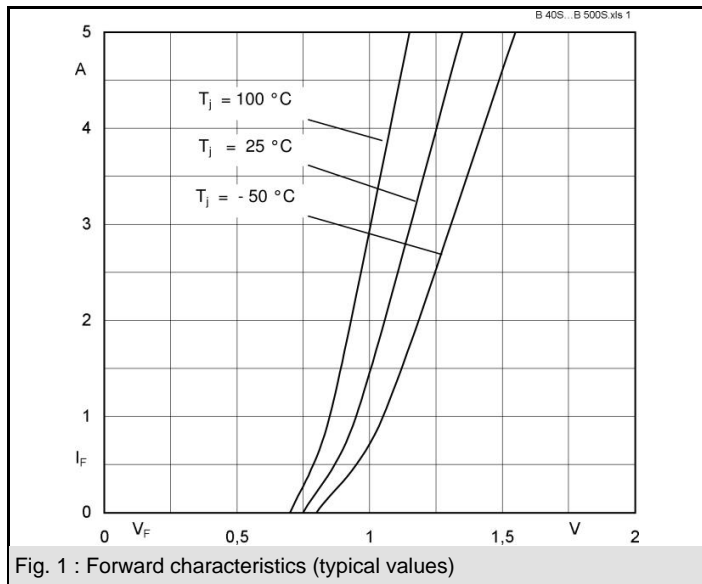

Fig. 1 : Forward characteristics (typical values)

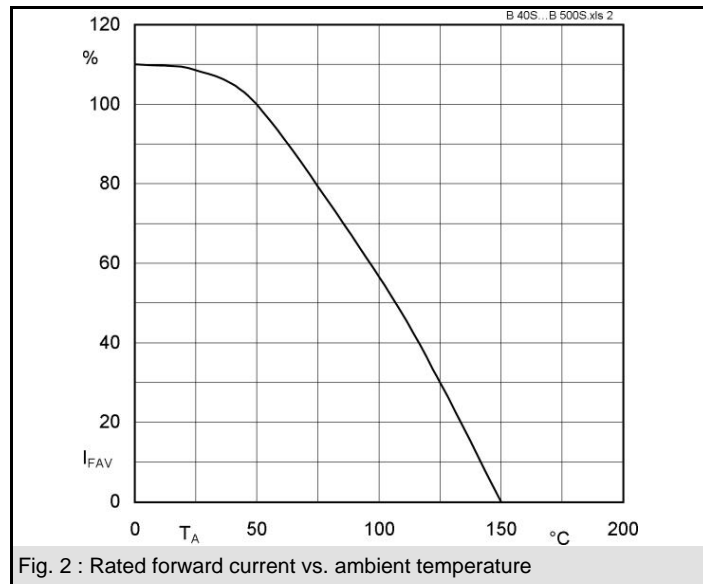

Fig. 2 : Rated forward current vs. ambient temperature