

STRUCTURE Silicon Monolithic Integrated Circuit

PRODUCT SERIES 7ch Stepping Motor Driver

TYPE **BD6876GUW**

FEATURES

- Built in 6 Full-ON Drivers
- Built in 1 Linear Constant-Current Driver

Under Developing

● Absolute maximum ratings (Ta=25°C)

Parameter	Symbol	Limit	Unit
Power supply voltage	VCC	-0.5 to +6.5	V
Motor power supply voltage	VM	-0.5 to +6.5	V
Control input voltage	VIN	-0.5 to VCC+0.5	V
Power dissipation	Pd	1020* ¹	mW
Operating temperature range	Topr	-25 to +85	°C
Junction temperature	Tjmax	150	°C
Storage output current	Tstg	-55 to +150	°C
H-bridge output current	Iout	-800 to +800* ²	mA/ch

*¹ Reduced by 8.16mW/°C over 25°C, when mounted on a glass epoxy board (114.3mm x 76.2mm x 1.6mm).

*² Must not exceed Pd, ASO, or Tjmax of 150°C.

● Operating Conditions (Ta=-25°C to +85°C)

Parameter	Symbol	Min.	Typ.	Max.	Unit
Power supply voltage	VCC	2.5	3.0	5.5	V
Motor power supply voltage	VM	2.5	5.0	5.5	V
Control input voltage	VIN	0	-	VCC	V
H-bridge output current	Iout	-	-	±500* ³	mA/ch

*³ Must not exceed Pd or ASO.

The product described in this specification is a strategic product (and/or service) subject to COCOM regulations. It should not be exported without authorization from the appropriate government authorities. This product isn't designed for protection against radioactive rays.

● Package Outline

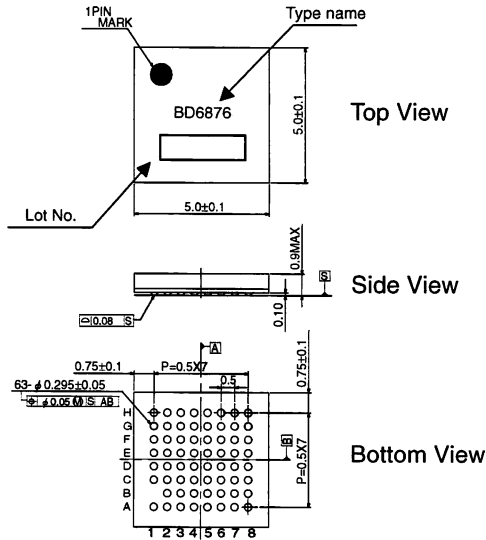

Fig.1 VBGA063W050 Package (Unit: mm)

● Pin Arrangement (Bottom View)

H	INPUT7	VCC	RNF	N.C.	ENABLE7	ENABLE1	VLIM	VREF
G	ENABLE2	N.C.	SENSE	OUT7B	OUT7A	BRAKE1	N.C.	PS
F	BRAKE2	INPUT2	N.C.	N.C.	VM5	N.C.	DGND	PGND2
E	OUT1A	OUT1B	PGND1	N.C.	INPUT1	N.C.	OUT3B	OUT3A
D	VM1	PGND1	N.C.	ENABLE5	N.C.	N.C.	VM2	OUT4B
C	OUT2A	OUT2B	N.C.	OUT6B	VM3	ENABLE4	OUT4A	PGND2
B	N.C.	ENABLE6	BRAKE5	N.C.	N.C.	BRAKE4	BRAKE3	INPUT3
A	BRAKE6	INPUT6	INPUT5	OUT6A	OUT5A	OUT5B	INPUT4	ENABLE3
	1	2	3	4	5	6	7	8

Fig.2 BD6876GUW Pin Arrangement (Bottom View)

● Block Diagram

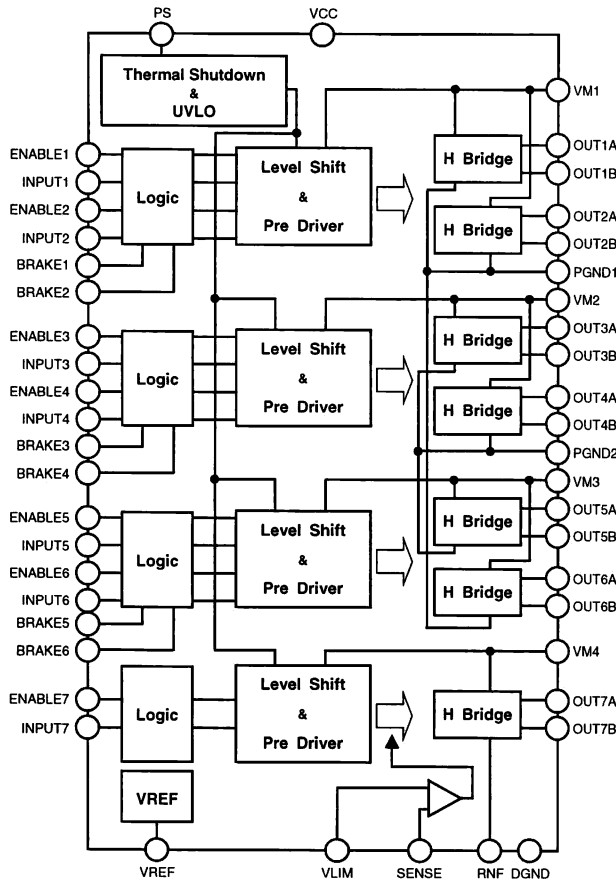

Fig.3 BD6876GUW Block Diagram

● Pin No. and Pin Name

No.	Pin name	No.	Pin name	No.	Pin name
1A	BRAKE6	1D	VM1	1G	ENABLE2
2A	INPUT6	2D	PGND1	2G	N.C.
3A	INPUT5	3D	N.C.	3G	SENSE
4A	OUT6A	4D	ENABLE5	4G	OUT7B
5A	OUT5A	5D	N.C.	5G	OUT7A
6A	OUT5B	6D	N.C.	6G	BRAKE1
7A	INPUT4	7D	VM2	7G	N.C.
8A	ENABLE3	8D	OUT4B	8G	PS
1B	N.C.	1E	OUT1A	1H	INPUT7
2B	ENABLE6	2E	OUT1B	2H	VCC
3B	BRAKE5	3E	PGND1	3H	RNF
4B	N.C.	4E	N.C.	4H	N.C.
5B	N.C.	5E	INPUT1	5H	ENABLE7
6B	BRAKE4	6E	N.C.	6H	ENABLE1
7B	BRAKE3	7E	OUT3B	7H	VLIM
8B	INPUT3	8E	OUT3A	8H	VREF
1C	OUT2A	1F	BRAKE2		
2C	OUT2B	2F	INPUT2		
3C	N.C.	3F	N.C.		
4C	OUT6B	4F	N.C.		
5C	VM3	5F	VM5		
6C	ENABLE4	6F	N.C.		
7C	OUT4A	7F	DGND		
8C	PGND2	8F	PGND2		

●BD6876GUW Electrical Characteristics (Unless otherwise specified, Ta=25°C, VCC=3.0V, VM=5.0V)

Parameter	Symbol	Target Limit			Unit	Conditions
		Min.	Typ.	Max.		
Overall						
Circuit current during standby operation	ICCST		0		μA	PS=L
Circuit current	ICC		1.5		mA	PS=H with no signal
Control input						
High level input voltage	VINH		-		V	ENABLEx, INPUTx, BRAKEx, PS
Low level input voltage	VINL		-		V	ENABLEx, INPUTx, BRAKEx, PS
High level input current	IINH		30		μA	ENABLEx, INPUTx, BRAKEx, PS, VIN=3V
Low level input current	IINL		0		μA	ENABLEx, INPUTx, BRAKEx, PS, VIN=0V
Pull-down resistor	RIN		100		kΩ	
UVLO						
UVLO voltage	VUVLO		-		V	
Full-ON Drive block (ch1 to ch6)						
Output ON-Resistance 1	RON1		1.2		Ω	VM=5V, Io=±400mA on high and low sides in total
Output ON-Resistance 2	RON2		1.5		Ω	VM=3V, Io=±400mA on high and low sides in total ^{*4}
Turn-on time	ton		0.6		μs	With 20Ω load
Turn-off time	toff		0.08		μs	With 20Ω load
Rise time	tr		0.15		μs	With 20Ω load
Fall time	tf		0.03		μs	With 20Ω load
Linear Constant-Current Drive block (ch7)						
Output ON-Resistance 1	RON1		1.0		Ω	VM=5V, Io=±400mA on high and low sides in total
Output ON-Resistance 2	RON2		1.2		Ω	VM=3V, Io=±400mA on high and low sides in total ^{*4}
VREF output voltage	VREF		0.90		V	Iout=0~1mA
Output limit voltage 1	VOL1		300		mV	RNF=1.5Ω, VLIM=0.3V
Output limit voltage 2	VOL2		450		mV	RNF=1.5Ω, VLIM=0.45V
Output limit voltage 3	VOL3		200		mV	RNF=0.5Ω, VLIM=0.2V
Turn-on time 1	ton1		1.0		μs	For ENABLE signal input with 10Ω load
Turn-on time 2	ton2		1.0		μs	For INPUT signal input with 10Ω load
Turn-off time	toff		0.1		μs	With 10Ω load
Rise time	tr		0.5		μs	With 10Ω load
Fall time	tf		0.03		μs	With 10Ω load

^{*4}Design target value (No total shipment inspection is made.)

●Operation Notes

(1) Absolute maximum ratings

Use of the IC in excess of absolute maximum ratings such as the applied voltage or operating temperature range (Topr) may result in IC damage. Assumptions should not be made regarding the state of the IC (short mode or open mode) when such damage is suffered. The implementation of a physical safety measure such as a fuse should be considered when use of the IC in a special mode where the absolute maximum ratings may be exceeded is anticipated.

(2) Power supply lines

Regenerated current may flow as a result of the motor's back electromotive force. Insert capacitors between the power supply and ground pins to serve as a route for regenerated current. Determine the capacitance in full consideration of all the characteristics of the electrolytic capacitor, because the electrolytic capacitor may lose some capacitance at low temperatures. If the connected power supply does not have sufficient current absorption capacity, regenerative current will cause the voltage on the power supply line to rise, which combined with the product and its peripheral circuitry may exceed the absolute maximum ratings. It is recommended to implement a physical safety measure such as the insertion of a voltage clamp diode between the power supply and GND pins.

(3) Ground potential

Ensure a minimum GND pin potential in all operating conditions.

(4) Setting of heat

Use a thermal design that allows for a sufficient margin in light of the power dissipation (Pd) in actual operating conditions.

(5) Actions in strong magnetic field

Use caution when using the IC in the presence of a strong magnetic field as doing so may cause the IC to malfunction.

(6) ASO

When using the IC, set the output transistor for the motor so that it does not exceed absolute maximum ratings or ASO.

(7) Thermal shutdown circuit

This IC incorporates a TSD (thermal shutdown) circuit (TSD circuit). If the temperature of the chip reaches the following temperature, the motor coil output will be opened. The thermal shutdown circuit (TSD circuit) is designed only to shut the IC off to prevent runaway thermal operation. It is not designed to protect the IC or guarantee its operation. Do not continue to use the IC after operating this circuit or use the IC in an environment where the operation of this circuit is assumed.

TSD ON temperature [°C] (Typ.)	Hysteresis temperature [°C] (Typ.)
175	25

(8) Ground Wiring Pattern

When using both small signal and large current GND patterns, it is recommended to isolate the two ground patterns, placing a single ground point at the application's reference point so that the pattern wiring resistance and voltage variations caused by large currents do not cause variations in the small signal ground voltage. Be careful not to change the GND wiring pattern of any external components, either.

Notes

- No technical content pages of this document may be reproduced in any form or transmitted by any means without prior permission of ROHM CO.,LTD.
- The contents described herein are subject to change without notice. The specifications for the product described in this document are for reference only. Upon actual use, therefore, please request that specifications to be separately delivered.
- Application circuit diagrams and circuit constants contained herein are shown as examples of standard use and operation. Please pay careful attention to the peripheral conditions when designing circuits and deciding upon circuit constants in the set.
- Any data, including, but not limited to application circuit diagrams information, described herein are intended only as illustrations of such devices and not as the specifications for such devices. ROHM CO.,LTD. disclaims any warranty that any use of such devices shall be free from infringement of any third party's intellectual property rights or other proprietary rights, and further, assumes no liability of whatsoever nature in the event of any such infringement, or arising from or connected with or related to the use of such devices.
- Upon the sale of any such devices, other than for buyer's right to use such devices itself, resell or otherwise dispose of the same, no express or implied right or license to practice or commercially exploit any intellectual property rights or other proprietary rights owned or controlled by
- ROHM CO., LTD. is granted to any such buyer.
- Products listed in this document are no antiradiation design.

The products listed in this document are designed to be used with ordinary electronic equipment or devices (such as audio visual equipment, office-automation equipment, communications devices, electrical appliances and electronic toys).

Should you intend to use these products with equipment or devices which require an extremely high level of reliability and the malfunction of which would directly endanger human life (such as medical instruments, transportation equipment, aerospace machinery, nuclear-reactor controllers, fuel controllers and other safety devices), please be sure to consult with our sales representative in advance.

About Export Control Order in Japan

Products described herein are the objects of controlled goods in Annex 1 (Item 16) of Export Trade Control Order in Japan.

In case of export from Japan, please confirm if it applies to "objective" criteria or an "informed" (by MITI clause) on the basis of "catch all controls for Non-Proliferation of Weapons of Mass Destruction.

Thank you for your accessing to ROHM product informations.
More detail product informations and catalogs are available,
please contact your nearest sales office.

Please contact our sales offices for details ;

U.S.A / San Diego	TEL : +1(858)625-3630	FAX : +1(858)625-3670
Atlanta	TEL : +1(770)754-5972	FAX : +1(770)754-0691
Dallas	TEL : +1(972)312-8818	FAX : +1(972)312-0330
Germany / Dusseldorf	TEL : +49(2154)9210	FAX : +49(2154)921400
United Kingdom / London	TEL : +44(1)908-282-666	FAX : +44(1)908-282-528
France / Paris	TEL : +33(0)1 56 97 30 60	FAX : +33(0) 1 56 97 30 80
China / Hong Kong	TEL : +852(2)740-6262	FAX : +852(2)375-8971
Shanghai	TEL : +86(21)6279-2727	FAX : +86(21)6247-2066
Dilian	TEL : +86(411)8230-8549	FAX : +86(411)8230-8537
Beijing	TEL : +86(10)8525-2483	FAX : +86(10)8525-2489
Taiwan / Taipei	TEL : +866(2)2500-6956	FAX : +866(2)2503-2869
Korea / Seoul	TEL : +82(2)8182-700	FAX : +82(2)8182-715
Singapore	TEL : +65-6332-2322	FAX : +65-6332-5662
Malaysia / Kuala Lumpur	TEL : +60(3)7958-8355	FAX : +60(3)7958-8377
Philippines / Manila	TEL : +63(2)807-6872	FAX : +63(2)809-1422
Thailand / Bangkok	TEL : +66(2)254-4890	FAX : +66(2)256-6334

Japan /
(Internal Sales)

Tokyo	2-1-1, Yaesu, Chuo-ku, Tokyo 104-0082	TEL : +81(3)5203-0321	FAX : +81(3)5203-0300
Yokohama	2-4-8, Shin Yokohama, Kohoku-ku, Yokohama, Kanagawa 222-8575	TEL : +81(45)476-2131	FAX : +81(45)476-2128
Nagoya	Dainagayo Building 9F 3-28-12, Meieki, Nakamura-ku, Nagoya, Aichi 450-0002	TEL : +81(52)581-8521	FAX : +81(52)561-2173
Kyoto	579-32 Higashi Shiokouji-cho, Karasuma Nishi-iru, Shiokoujidori, Shimogyo-ku, Kyoto 600-8216	TEL : +81(75)311-2121	FAX : +81(75)314-6559

(Contact address for overseas customers in Japan)

Yokohama	TEL : +81(45)476-9270	FAX : +81(045)476-9271
----------	-----------------------	------------------------