

The C7390 Series X-ray line sensor camera offers high resolution and high sensitivity for capturing finely detailed X-ray images of products or parts moving along on a belt conveyor. X-ray images are obtained in synchronization with external timing signals from the transfer mechanism such as a belt conveyor or by internal timing signals, and are then output as RS-422 digital signals.

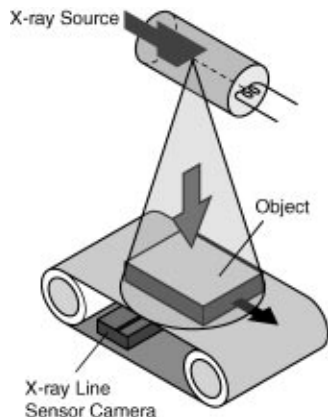

FEATURES

- High resolution
- Equipment with wider detection areas
- Available with 256 mm or 512 mm detector length
- Easily connectable to frame grabber board
The signal output method of this X-ray line sensor camera is designed to handle commercially available, digital frame grabber boards.

APPLICATIONS

- Detection of foreign matter in the food processing industry
- Presense of dangerous objects in incinerators, like gas bottles, fire extinguishers
- X-ray tomography for inspection of fuel tanks, moving parts in engines.

SPECIFICATIONS

Scintillator Material	Gd plastic scintillator
Effective X-ray tube voltage range	40 to 160 kV
Sensor element pitch	0.4 mm
Detection width	512 mm or 256 mm
Resolution	512 mm: 1280 pixels
	256 mm: 640 pixels
Line speed	4 to 40 m/min
A/D conversion	12 bits
Digital Interface	RS-422
External Control	RS-232C
Correction functions	Offset and Brightness
Operating temperature	0 to 40°C
Storage temperature	-10 to +50°C
Operating and storage humidity	30 to 80% (no condensation)
Line Voltage	AC100/117/220/240±10% 50/60Hz
Power consumption	Approx. 100VA

SYSTEM CONFIGURATION EXAMPLE

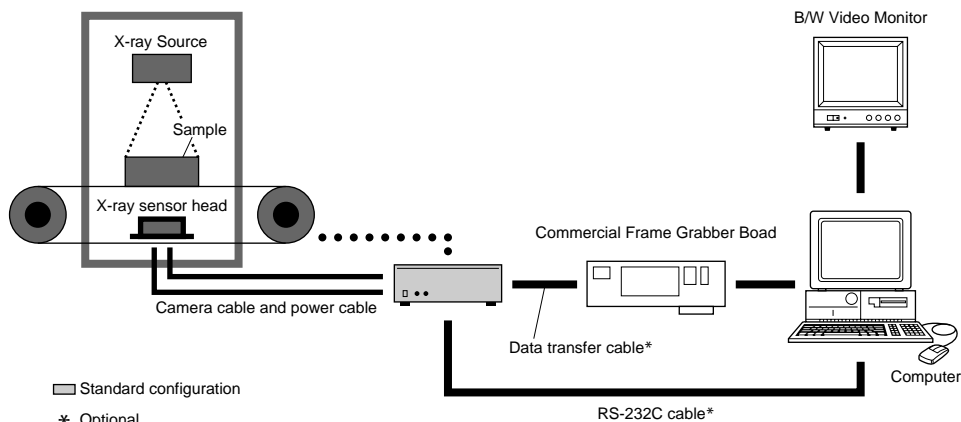

NOTE

- The C7390 X-ray line sensor camera consists of a sensor head, sensor control unit and cables. Image display equipment should be ordered separately.

STANDARD CONFIGURATION

- X-ray sensor head 1
- Sensor control unit..... 1
- Camera cable (5 meters) 1
- Camera power cable (5 meters) 1
- Power cable (2 meters) 1
- Accessories (Instruction manual) 1
- (Fuse)..... 1

OPTIONAL

● Processor board

This is designed to be installed in a computer and has functions to display an image while scrolling the acquired data, freeze the image at the desired timing and control the sensor head, just as with the above display.

● Data transfer cables

Custom data transfer cables are provided to match the particular application. For example, cables are supplied in lengths of 5, 10 and 20 meters to handle relatively long distances to the video monitor. Please consult with us if even longer cables are needed.

APPLICATION EXAMPLES

- Field pea

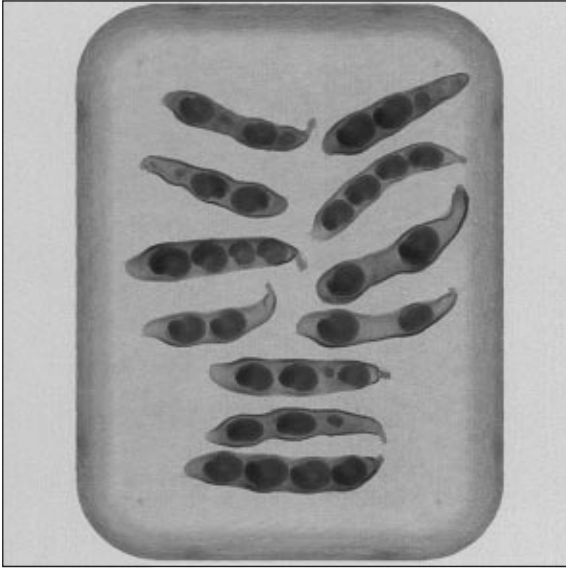

- Green pepper

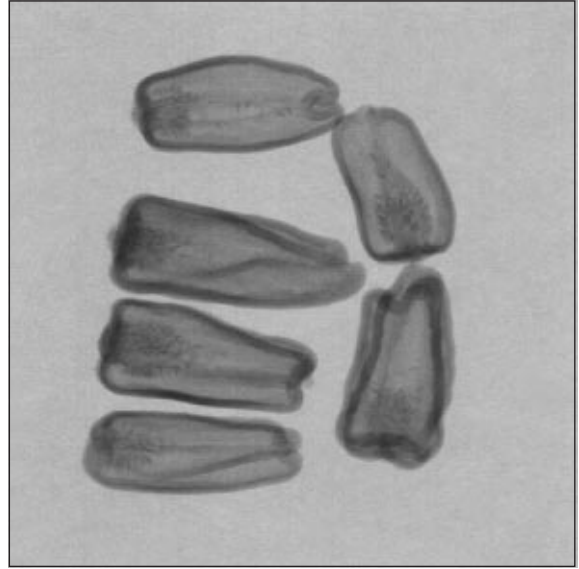

- Fish



- Chicken



- Incinerators, like gas bottles

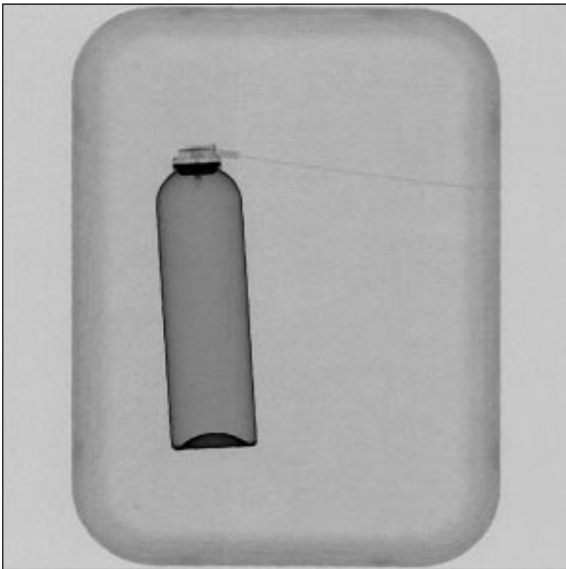

- Shoes



DIMENSIONAL OUTLINE (Unit:mm)

• X-Ray Line Sensor Head (512 mm) (Approx. 9.0 kg)

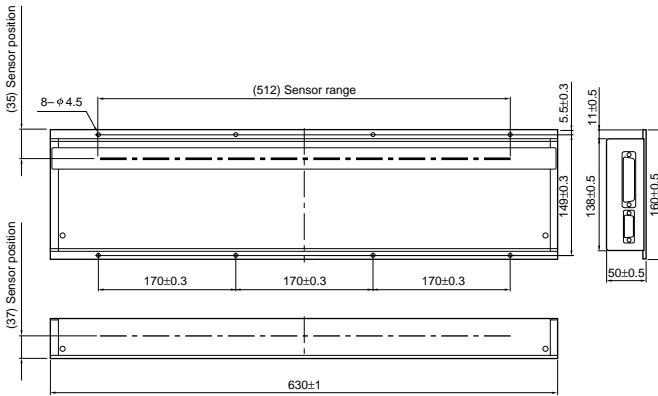

- C7390-01 : AC100V ± 10%
- C7390-06 : AC117V ± 10%
- C7390-11 : AC220V ± 10%
- C7390-16 : AC240V ± 10%

• X-Ray Line Sensor Head (256 mm) (Approx. 5.0 kg)

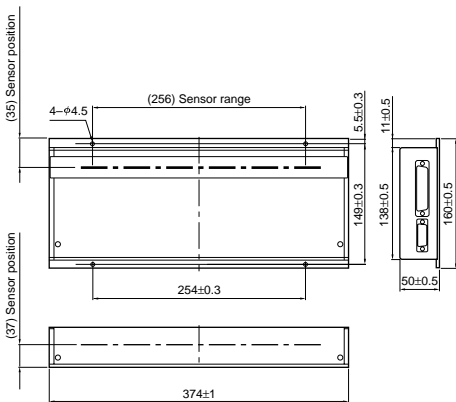

- C7390-02 : AC100V ± 10%
- C7390-07 : AC117V ± 10%
- C7390-12 : AC220V ± 10%
- C7390-17 : AC240V ± 10%

• Sensor Camera Control Unit (Approx. 5.0 kg)

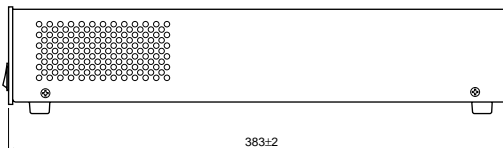
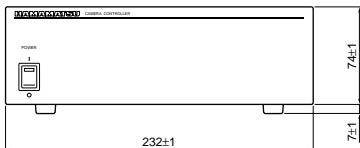
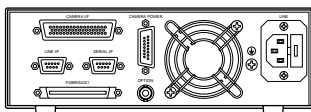

- Subject to local technical requirements and regulations, availability of products included in this promotional material may vary. Please consult with our sales office.
 - Information furnished by HAMAMATSU is believed to be reliable. However, no responsibility is assumed for possible inaccuracies or omissions. Specifications and external appearance are subject to change without notice.
- © 1998 Hamamatsu Photonics K.K.

HAMAMATSU

Homepage Address <http://www.hamamatsu.com>

HAMAMATSU PHOTONICS K.K., Systems Division
812 Joko-cho, Hamamatsu City, 431-3196, Japan, Telephone: (81)53-431-0124, Fax: (81)53-435-1574, E-mail: export@sys.hpk.co.jp

U.S.A. and Canada: Hamamatsu Photonic Systems: 360 Foothill Road, Bridgewater, N.J. 08807-0910, U.S.A., Telephone: (1)908-231-1116, Fax: (1)908-231-0852

Germany: Hamamatsu Photonics Deutschland GmbH: Arzbergerstr. 10, D-82211 Herrsching am Ammersee, Germany, Telephone: (49)8152-375-0, Fax: (49)8152-2658

France: Hamamatsu Photonics France S.A.R.L.: 8, Rue du Saule Trapu, Parc du Moulin de Massy, 91882 Massy Cedex, France, Telephone: (33)1 69 53 71 00, Fax: (33)1 69 53 71 10

United Kingdom: Hamamatsu Photonics UK Limited: Lough Point, 2 Gladbeck Way, Windmill Hill, Enfield, Middlesex EN2 7JA, United Kingdom, Telephone: (44)181-367-3560, Fax: (44)181-367-6384

North Europe: Hamamatsu Photonics Norden AB: Färögatan 7, S-164-40 Kista, Sweden, Telephone: (46)8-703-29-50, Fax: (46)8-750-58-95

Italy: Hamamatsu Photonics Italia S.R.L.: Via Della Moia, 1/E 20020 Arese, (Milano), Italy, Telephone: (39)2-935 81 733, Fax: (39)2-935 81 741

Cat. No. SICS1065E03
DEC/98 CR
Created in Japan (PDF)