

2A SINK & SOURCE ADJUSTABLE LINEAR BUS TERMINATOR

GENERAL DESCRIPTION

The CM8562P is a low cost linear regulator designed to provide a desired output voltage or termination voltage for various applications by converting voltage supplies ranging from 1V to 6.0V. The desired output voltage could be programmable by two external voltage divider resistors.

The CM8562P is capable of sourcing or sinking up to 2A of current while regulating an output VOUT voltage to within 2% (DDR-I), 3% (DDR-II) or less.

The CM8562P provides low profile 8-pin SOIC package to save system space.

FEATURES

- ◆ Ideal for DDR-I and DDR-II
- ◆ 8-pin SOIC w/ power pad package
- ◆ Source and sink up to 2A, no heat sink required
- ◆ Integrated power MOSFETs
- ◆ Programmable output voltage by external resistors
- ◆ Output voltage could go down to 0.6V
- ◆ Iccq at VCCA less than 500uA
- ◆ Current limit protection and Short Circuit protection
- ◆ Thermal shutdown protection
- ◆ Shutdown for standby or suspend mode operation
- ◆ Minimum external components

APPLICATIONS

- ◆ Mother Board
- ◆ PCI/AGP Graphics
- ◆ Game/ Play Station
- ◆ Set Top Box
- ◆ IPC
- ◆ SCSI-III Bus terminator

PIN CONFIGURATION

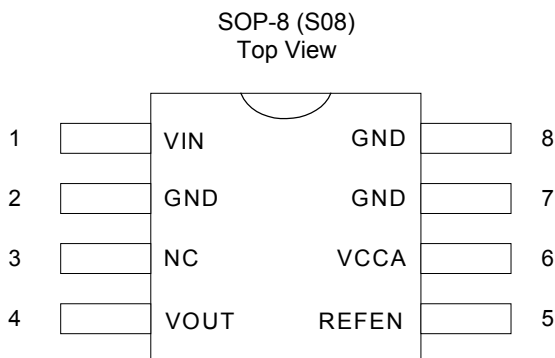

PIN DESCRIPTION

Pin No.	Symbol	Description	Operating Rating			Unit
			Min.	Typ.	Max.	
1	VIN	Input Power	1	2.5/1.8	6	V
3	NC	No Connection				
4	VOUT	Output Voltage			VCCA-1.9	V
5	REFEN	Reference Voltage Input and Chip Enable			VCCA-1.9	V
6	VCCA	Voltage supply for internal circuits			6	V
2,7,8	GND	Ground				

ORDERING INFORMATION

Part Number	Temperature Range	Package
CM8562PIS	-40°C to 85°C	8-Pin SOP (S08)
CM8562PGIS*	-40°C to 85°C	8-Pin SOP (S08)

*Note: G : Suffix for Pb Free Product

BLOCK DIAGRAM

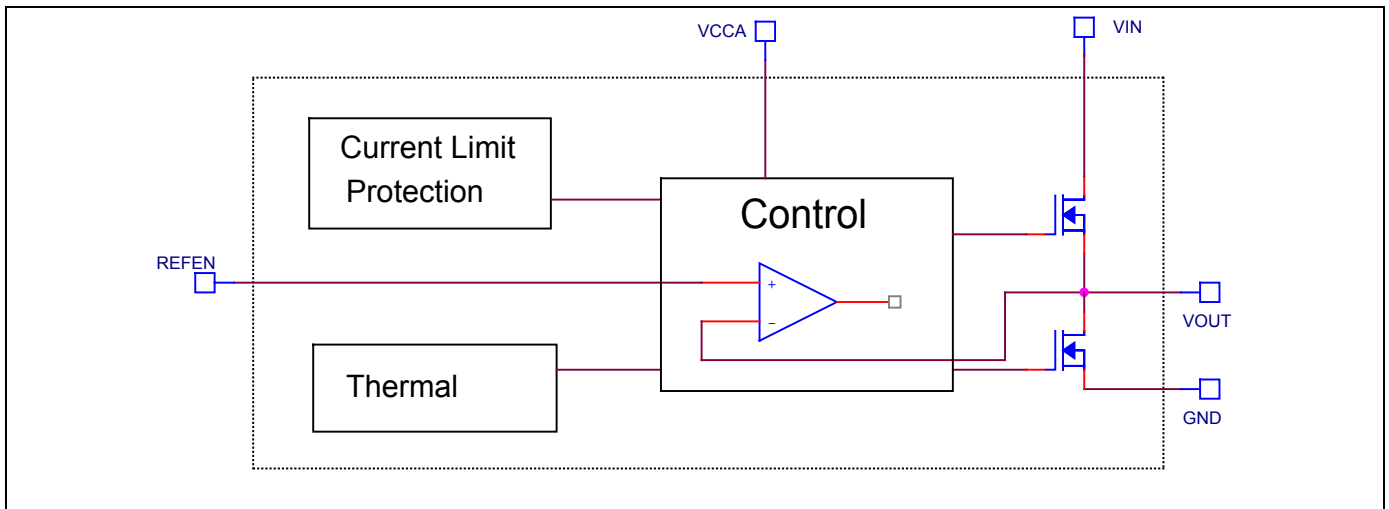

APPLICATION CIRCUITS

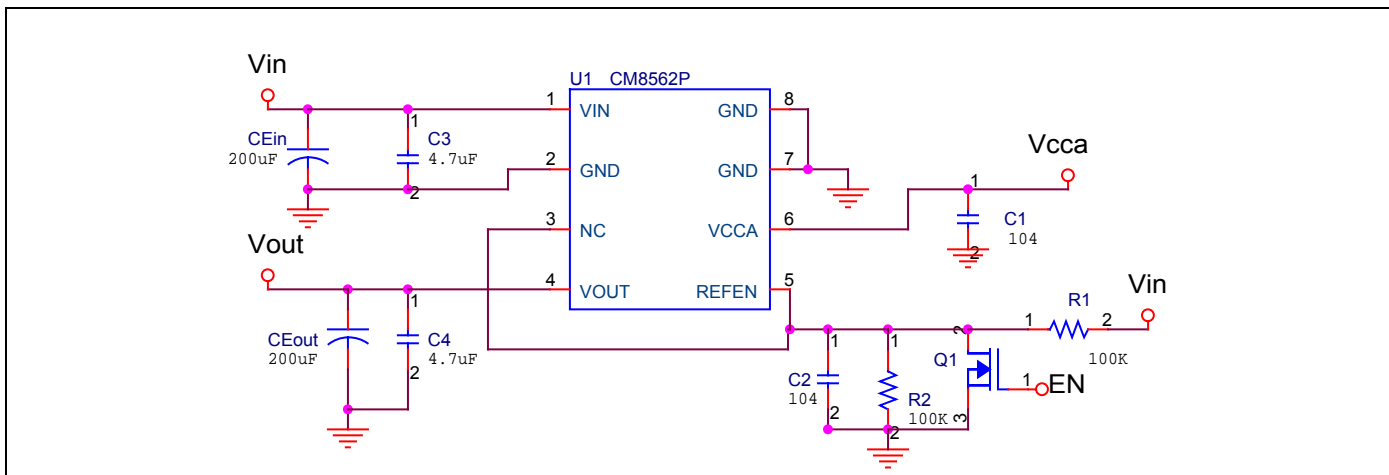

2A SINK & SOURCE ADJUSTABLE LINEAR BUS TERMINATOR
ABSOLUTE MAXIMUM RATINGS

Absolute maximum ratings are those values beyond which the device could be permanently damaged.

VIN, VCCA7V
 Output RMS Current, Source or Sink2A

Storage Temperature -65°C to 125°C
 Lead Temperature (Soldering, 5 sec)..... 260°C
 Thermal Resistance(θ_{JC})..... 14°C/W (PSOP-8)

ELECTRICAL CHARACTERISTICS (Unless otherwise stated, these specifications apply $T_A=25^\circ\text{C}$; $V_{IN}=+2.5\text{V}$ and $V_{CCA}=+3.3\text{V}$, $V_{REFEN}=1.25\text{V}$) maximum ratings are stress ratings only and functional device operation is not implied. (Note 1)

Symbol	Parameter	Test Conditions	CM8562P			Unit
			Min.	Typ.	Max.	
V _{OS}	Output Offset Voltage	I _{OUT} =0A (Note 2)	-20		20	mV
I _{OP}	Operating Current at VIN	No load, C _{out} =200uF			1	mA
ΔV_{LOAD}	Load Regulation (DDR I/II)	I _L : 0A -> 2A		0.8/1.2	2/3	%
		I _L : 0A -> -2A		0.8/1.2	2/3	%
V _{DROPOUT}	Dropout Voltage	V _{CCA} >V _{OUT} +1.9V, I _{OUT} =2A		0.3	0.4	V
		V _{CCA} >V _{OUT} +1.9V, I _{OUT} =1.5A		0.2	0.25	V
I _{CCQ}	Quiescent Current at V _{CCA}	At Room Temp.		190	230	μA
I _{SHDN}	Current in Shutdown Mode	REFEN<0.2V, R _L = 10 Ohm		90	110	μA
V _{IN}	Input Voltage Range (Note 3)	No Load	1	2.5/1.8	6	V
V _{CCA}	Input Voltage Range (Note 3)	R _L = 10 Ohm	3.15	3.3	6	V
SHORT CIRCUIT PROTECTION						
I _{LIMIT}	Current Limit			5		A
I _{SC,VIN}	Short Current	Sinking	2			A
I _{SC,GND}	Short Current	Sourcing	2			A
OVER THERMAL PROTECTION						
THSD	Thermal Shutdown Temperature	3.15V<=V _{CCA} <=6V	125	150	155	°C
	Thermal Shutdown Hysteresis		25	30	35	°C
REFEN FUNCTION						
	REFEN Threshold	V _{REFEN} < V _{IN} V _{REFEN} < V _{CCA} - 1.9V	0.4	0.5	0.6	V

Note 1: Limits are guaranteed by 100% testing, sampling, or correlation with worst case test conditions

Note 2: V_{OS} = V_{REFEN} - V_{OUT}

Note 3: Keep V_{CCA} >= V_{IN} and V_{CCA} >= V_{REFEN} + 1.9V on operation power on and power off sequences

Note 4: Guaranteed by design, not 100% test

FUNCTIONAL DESCRIPTION

The CM8562P is a linear regulator that is capable of sinking and sourcing 2A of current without an external heat sink.

The CM8562P integrates power MOSFETs that are capable of source and sink 2A of current while maintaining excellent voltage regulation. The output voltage can be regulated within 3% or less by using the external feedback. Separate voltage supply inputs have been added to fit applications with various power supplies for the databus and power buses.

OUTPUTS

The output voltage pins (VOUT) are tied to the databus, address, or clock lines via an external inductor. Output voltage is determined by the VIN.

INPUTS

The input voltage pins (VIN) determine the output voltages (VOUT). At CM8562P, the desired output voltage could be programmable by two external voltage divider resistors. VIN is suggested to connect to VDDQ of memory module for better tracking with memory VDDQ.

OTHER SUPPLY VOLTAGES

VCCA provide the voltage supply to the logic section and internal error amplifiers of CM8562P.

PACKAGE DIMENSION

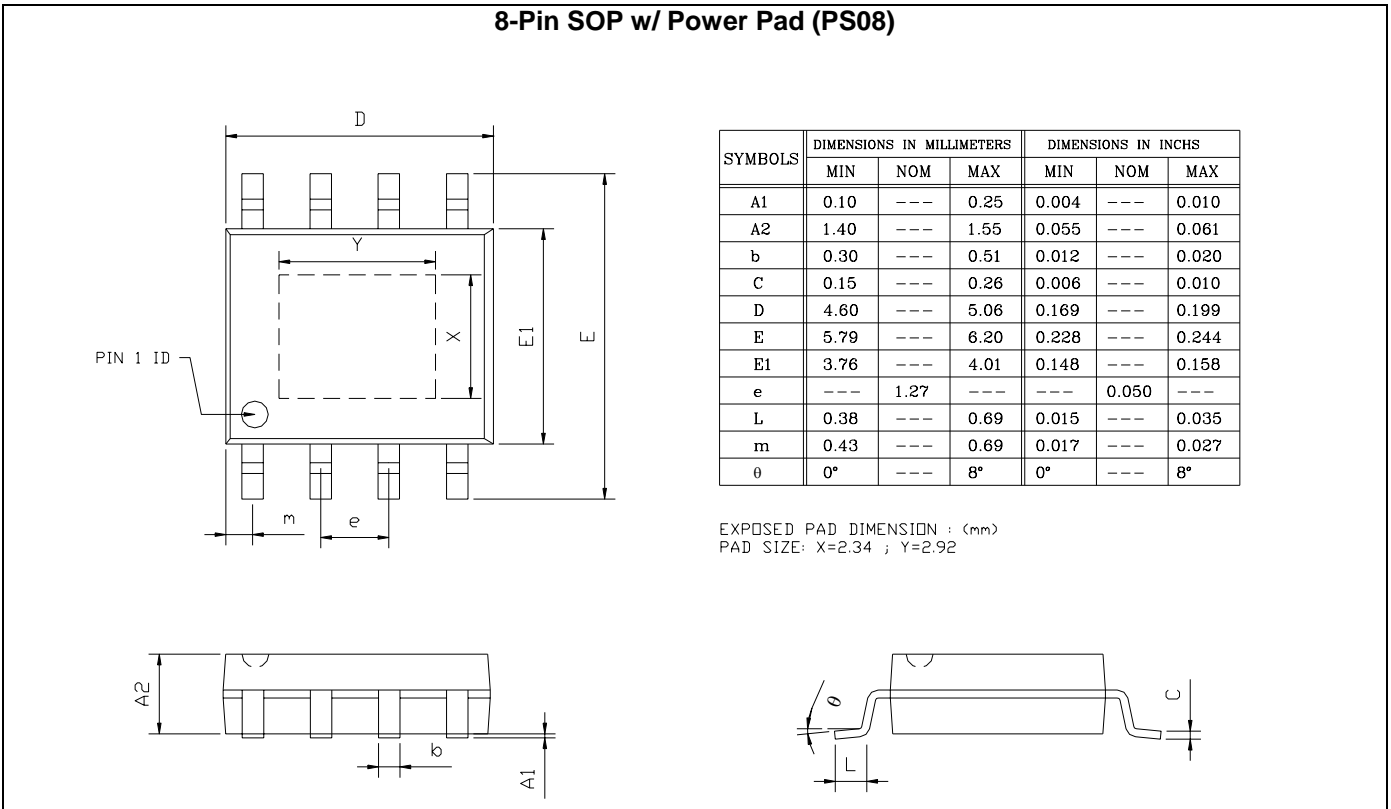

IMPORTANT NOTICE

Champion Microelectronic Corporation (CMC) reserves the right to make changes to its products or to discontinue any integrated circuit product or service without notice, and advises its customers to obtain the latest version of relevant information to verify, before placing orders, that the information being relied on is current.

A few applications using integrated circuit products may involve potential risks of death, personal injury, or severe property or environmental damage. CMC integrated circuit products are not designed, intended, authorized, or warranted to be suitable for use in life-support applications, devices or systems or other critical applications. Use of CMC products in such applications is understood to be fully at the risk of the customer. In order to minimize risks associated with the customer's applications, the customer should provide adequate design and operating safeguards.

HsinChu Headquarter

5F, No. 11, Park Avenue II,
Science-Based Industrial Park,
HsinChu City, Taiwan 300

TEL: +886-3-567 9979

FAX: +886-3-567 9909

<http://www.champion-micro.com>

Sales & Marketing

11F, No. 306-3, Sec. 1, Ta Tung Rd.,
Hsichih, Taipei Hsien,
Taiwan 221

TEL: +886-2-8692 1591

FAX: +886-2-8692 1596