

## DS1300-3

1300 Watts 12V

Distributed Power System

**Distributed Power Bulk Front-End**

**Total Output Power: 1300 Watts**

**+12vdc Main Output;**

**+3.3vdc Stand-by Output**

**Wide Range Input voltage: 90 - 264VAC**

**180 - 264vac 1300w**

**90 - 264vac 910W**



## Special Features

- Active Power Factor Correction
- EN61000-3-2 Harmonic Compliance
- Active AC Inrush Control
- 2U X 3U Form Factor 7.5" long
- 13W/ in<sup>3</sup>
- +12vdc Output
- +3.3vdc Stand-By
- Hot Plug Operation
- N + 1 Redundant
- Internal OR'ing Main and Stand-by
- Active Current Sharing
- Internal Cooling Fans (60mm x 38mm)
- I<sup>2</sup>C Communication Interface Bus
- EERPOM for FRU Data
- Green LED Status, Power OK
- Amber LED Status, Power Failed
- Internal Fan Speed Control
- Fan Fail Output Signal
- INTEL, SSI Std. Logic Timing
- INTEL, SSI Std. FRU Data Format
- AC shutdown <85VAC or 170VAC
- One Year Warranty

## Safety

UL/cUL 60950 (UL Recognized)  
1st edition (UL)60950-1-03 CSA  
NEMKO+ CB Report EN60950  
EN60950  
CE Mark  
China CCC  
CB Test Report

## Electrical Specifications

Input	
Input range	90-264 VAC, 910w 180 - 264 vac, 1300w
Frequency	47-63 Hz, single phase AC
Inrush current	35A maximum inrush current
Efficiency	>80% typical at full load, high line
Conducted EMI	FCC Subpart J EN55022 Class A
Radiated EMI	FCC Subpart J EN55022 Class A
Power factor	0.99 typical
Leakage current	0.75mA @ 240VAC
Hold up time	12ms minimum
Output	
Main DC voltage	+12v @ 74A (90VAC) or 106A (180VAC)
Stand-By	+3.3vsb @ 7A
Adjustment range	Factory Set, no pot adjustments
Regulation	+12vdc; ±3%; +3.3vsb; ±3%
Over current	+12vdc; 110 - 130% latches off if overcurrent lasts over 1.5 seconds, otherwise it is auto recovery.
Over voltage	+3.3vsb, 7A - 105% - 130% +12vdc; 13.7v ±7%
Under voltage	+3.3vsb; 4.0v ±7% +12vdc; 11.0 - 11.4vdc
Turn-on delay	<3 Second max
+12vOutput Rise Time	5 - <200mS, Monotonic Rise
I Share 12V	15% from 50 - 100% load



### Logic Control

PS_ON	An active low signal that turns on the 12vdc power rail. When this signal High, or left open, the 12vdc output turn off. The 3.3Vsb output remains on.
POK	Is a power good signal to be pulled low by the power supply to indicate that all the outputs are within regulation limits of the power supply. (turn-on delay 100 - 500mS)
PS FAIL	In the event of a power supply failure (OVP at any output, UV at any output, OTP or other electrical failure), this signal shall go to a High state.
AC OK	High when AC is not OK, Low if AC is OK
PRESENT	Low if PSU is Present, High if not Present; Pull high in system.
FAN FAIL	Low if one or both fans have failed
PS_KILL	This pin shall quickly turn off the power supply and prevent arcing of the DC output contacts.

## Environmental Specifications

Operating temperature:	-10° to 50°C ; 50% power derating at 70°C
Storage temperature:	-40°C to +85°C
Altitude, operating	10,000ft.
Electromagnetic susceptibility / Input transients:	EN61000-3-2, -3-3 EN61000-4-2, 4.3, 4-4, -4-5, 4-11 Level EN55024:1998 RoHS, RS5
Humidity:	5 to 95% RH, non-condensing
Shock and vibration specifications	complies with Astec Std. Specifications, Q3205
MTBF (Demonstrated)	500K Hrs at full load, 50°C
Anti-smoke Emission	Due to internal overload or internal failures
Fan life:	70,000 hrs @ 40°C

### Ordering Information

Output	Nominal Output Voltage Set Point	Set Point Tolerance	Total Regulation	Minimum Current	Maximum Current	Output Ripple P/P
Main (>90VAC)	12.00vdc	±0.2%	±3%	0A	74A	120mV
Main (180VAC)	12.00vdc	±0.2%	±3%	1.0A	106A	120mV
Std-By	3.3vdc	±1%	±3%	0.5A	7.0A	50mV

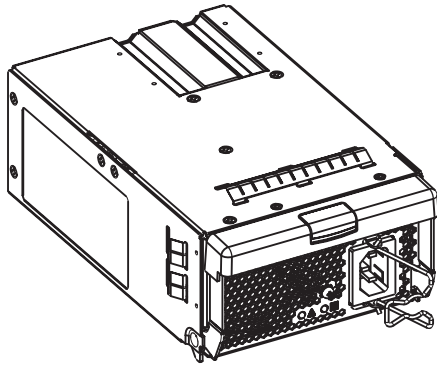

3D VIEW

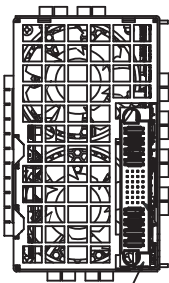
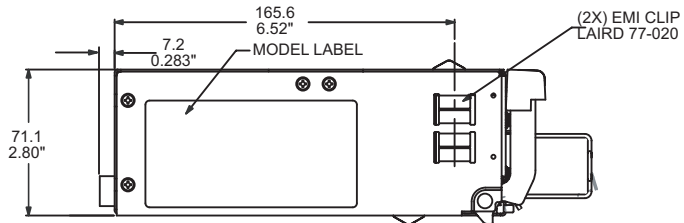
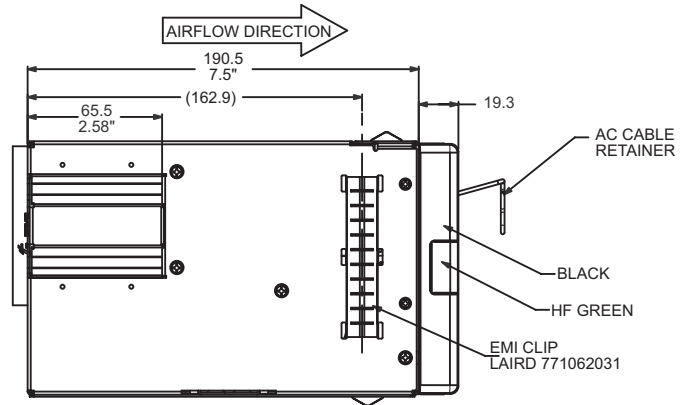

TYCO P/N 1-1450330-8 OR  
FCI P/N 51939-055

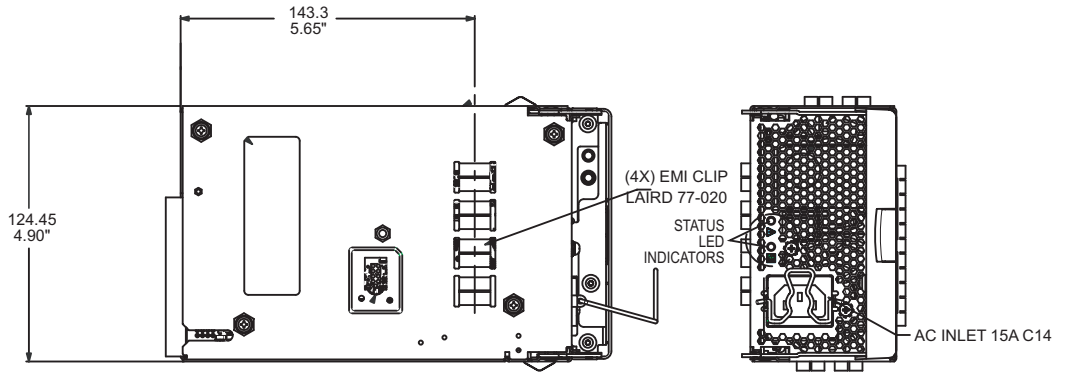

NOTE: Dimensions given in mm and inches.

Power Supply Condition	Power Supply LED's	
	PWR (green)	FAIL (amber)
No AC power to all PSU	Off	Off
No AC power to this PSU only (includes No output, over voltage, over temperature)	OFF	On
AC present / Standby Output On	Blinking	Off
Power supply DC outputs ON and OK	ON	Off
Power supply failure (over current)	OFF	Blinking

## DC Output Connector Pinout Assignment

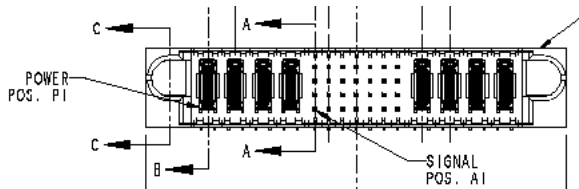

### Male connector as viewed from the rear of the supply

#### P1 - Unit

FCI Power blade FCI p/n  
51939-055

#### P1 - Mate

Mating Connector  
(System side)  
FCI Power blade  
Part number 51915-023

#### AC Input Connector EN60320 Type C14

Pin	Signal Name
PB P1	+12V
PB P2	+12V RETURN (Pre-mate)
PB P3	+12V
PB P4	+12V RETURN (Pre-mate)
PB P5	+12V
PB P6	+12V RETURN (Pre-mate)
PB P7	+12V
PB P8	+12V RETURN (Pre-mate)
A1	+3V3 STAND-BY
A2	+3V3SB RETURN
A3	PS_PRESENT ( Power Supply Seated) - (short pin)
A4	POK (Output Power Ok)
A5	PS FAIL (Failure Signal)
A6	SPARE
A7	SPARE
B1	+3V3 STAND-BY
B2	+3V3SB RETURN
B3	PS_ON (Power Enable Signal)
B4	PS_KILL (Power Supply Fast Shutdown) - (short pin)
B5	SDA (I2C Data Signal)
B6	A2 (I2C Address BIT 2 Signal)
B7	FAN_FAIL (Fan Fail Signal)
C1	+3V3 STAND-BY
C2	+3V3SB RETURN
C3	AC_OK (AC Input Present)
C4	+12V RMT SENSE
C5	+12V RMT SENSE RETURN
C6	A1 (I2C Address BIT 1 Signal)
C7	+3V3 STAND-BY RMT SENSE Return (-)
D1	+3V3 STAND-BY
D2	+3V3SB RETURN
D3	12IS (+12V Current Share)
D4	SPARE
D5	SCL (I2C Clock Signal)
D6	A0 (I2C Address BIT 0 Signal)
D7	+3V3 STAND-BY RMT SENSE (+)

## Astec Power

5810 Van Allen Way  
Carlsbad, CA 92008  
USA  
Telephone: +1 760 930 4600  
Facsimile: +1 760 930 0698  
Technical Support: +1 888 41 ASTEC  
or +1 407 241 2752

Waterfront Business Park  
Merry Hill, Dudley  
West Midlands, DY5 1LX  
United Kingdom  
Telephone: +44 (0) 1384 842 211  
Facsimile: +44 (0) 1384 843 355

Units 2111-2116, Level 21  
Tower 1, Metroplaza  
223, Hing Fong Road  
Kwai Fong, New Territories  
Hong Kong  
Telephone: +852 2437 9662  
Facsimile: +852 2402 4426

For global contact, visit:

[www.astecpower.com](http://www.astecpower.com)  
[technicalsupport@astec.com](mailto:technicalsupport@astec.com)

While every precaution has been taken to ensure accuracy and completeness in this literature, Astec Power assumes no responsibility, and disclaims all liability for damages resulting from use of this information or for any errors or omissions.

Printed in USA

**Emerson Network Power.**  
The global leader in enabling  
business-critical continuity.

- AC Power
- Connectivity
- DC Power
- Embedded Power**
- Inbound Power
- Integrated Cabinet Solutions
- Outside Plant
- Precision Cooling
- Site Monitoring and Services

**EmersonNetworkPower.com**

Emerson Network Power and the Emerson Network Power logo are trademarks and service marks of Emerson Electric Co.  
©2006 Emerson Electric Co.