

Energy Management Energy Analyzer Type EM11 DIN



- Class 1 (kWh) according to EN62053-21
- Class 2 (kvarh) according to EN62053-23
- Accuracy ± 0.5 RDG (current/voltage)
- Energy analyzer
- Instantaneous variables readout: 4 DGT
- Energies: 5+1 DGT
- Instantaneous variables: V, A, W, Wdmd, Wdmd max, var, PF, Hz
- Single phase variables: VLL, VLN, A, VA, W, var, PF
- Energy measurements: total kWh and kvarh
- TRMS measurements of distorted sine waves (voltages/currents)
- Self power supply
- Dimensions: 1-DIN module
- Protection degree (front): IP40
- 1 pulse output on request
- 1 alarm output on request
- MID "annex MI-003" (Measuring Instruments Directive) compliant

Product Description

One-phase energy analyzer with built-in configuration push button and LCD data displaying; particularly indicated for active and reactive energy metering and for cost allocation. Housing for DIN-rail mounting, IP40 (front) protection degree. Direct

connection up to 32A. Moreover the meter can be provided with either pulse output proportional to the active energy being measured or alarm control on the available instantaneous variables.

How to order **EM11 DIN AV8 1 X 01 X**



Type Selection

Range code	System	Power supply	Output
AV7: 120V _{LN} AC - 5(32)A (**) (direct connection)	1: 1-phase	X: Self power supply (from 48 to 62Hz). The instrument works on the range from -20% to +20% of the measuring input nominal voltage.	XX: None (**) O1: Pulse type (open collector output) (*) R1: Alarm type (relay output) (*) B1: Buzzer output (**)
AV8: 230V _{LN} AC - 5(32)A (*) (direct connection)			
	Option		
	X: None (*)		

(*) as standard.
(**) on request.

Input specifications

Rated inputs Current range (by shunt) Voltage range	System: 1 AV7 and AV8: 5(32)A AV7: 120 VLN AC AV8: 230 VLL AC	Active power Reactive power Active energy	$\pm(1\%RDG + 2DGT)$ $\pm(2\%RDG + 2DGT)$ Class 1 according to EN62053-21 and MID Annex MI-003 Class B. Class 2 according to EN62053-23.
Accuracy (Display) (@25°C $\pm 5^\circ C$, R.H. $\leq 60\%$, 48 to 62Hz) AV7 model AV8 model	lb: 5A, Imax: 32A; Un: 120VLN (-20% +20%) lb: 5A, Imax: 32A; Un: 230VLN (-20% +20%)	Reactive energy Reference values	lb: 5A, Imax: 32A, 0.1 lb: 0.5A 20mA
Current	From 0.04lb to 0.2lb: $\pm(0.5\% RDG + 3DGT)$ From 0.2lb to Imax: $\pm(0.5\% RDG + 1DGT)$.	Start up current:	
Voltage	In the Un range: $\pm(0.5\% RDG + 2DGT)$	Energy additional errors Influence quantities	According to EN62053-21, EN62053-23
Frequency	$\pm 0.1Hz$ (48 to 62Hz)	Temperature drift	$\leq 200ppm/^\circ C$
		Sampling rate	1600 samples/s @ 50Hz 1900 samples/s @ 60Hz



Input specifications

Display	1 line (max: 5+1 DGT)	Crest factor	1b 5A ≤4 (45A max. peak)
Type	LCD, h 7mm	Current Overload	
Instantaneous variables read-out	4 DGT (V and A) 3 DGT (W, var, Wdmd, Wdmd max, Hz, PF)	Continuous	32A, @ 50Hz
Min. Max. indication	Max. 9 999; Min. 0 (0.0)	For 10ms	960A, @ 50Hz
Energies	Total: 5+1 DGT	Voltage Overload	
LEDs	Red LED (Energy consumption), 1000 pulses/kWh (Max Frequency 16 Hz) according to EN62053-11	Continuous	1.2 Un
Measurements	See "Measuring variables and Min. Max. indications"	For 500ms	2 Un
Method	TRMS measurements of distorted wave forms	Input impedance	
Coupling type	Direct	120VL-N (AV7)	>720KΩ
		230VL-N (AV8)	>720KΩ
		5(32) A (AV7-AV8)	< 0.5VA
		Frequency	48 to 62 Hz
		Key-pad	1 push-button for variable selection and programming of the instrument working parameters

Output specifications

Digital output	(on request)		
Number of outputs	1	On-time delay	"Measuring variables and Min. Max. indications")
Type	Open collector, programmable from 0.001 to 1 kWh for each pulse.	Off-time delay	0 to 9999s (166min)
Signal	V _{ON} 1.2 VDC/ max. 100 mA V _{OFF} 30 VDC max.	Min. response time	0 to 9999s (166min)
Pulse duration	≥100ms < 120msec (ON), ≥120ms (OFF), according to EN62052-31	Insulation	≤ 1s, set-point on-time delay: "0 s"
Insulation	By means of optocouplers, 4000 VRMS output to measuring inputs	Buzzer	4000 VRMS output to measuring inputs
Alarm output	(on request)	Type	(on request)
Number of outputs	1	Alarm modes	It sounds when the alarm is ON
Type	Reed Relay, SPST type AC 1-5A @ 250VAC DC 12-5A @ 24VDC AC 15-1.5A @ 250VAC DC 13-1.5A @ 24VDC	Controlled variables	Beep type 70dB Up alarm or down alarm kW, kWdmd, kvar, PF, A, V, Hz
Alarm modes	Up alarm or down alarm	Set-point adjustment	Programmable on all the measuring range (see "Measuring variables and Min. Max. indications")
Controlled variables	kW, kWdmd, kvar, PF, A, V, Hz	Hysteresis	programmable on all the measuring range (see "Measuring variables and Min. Max. indications")
Set-point adjustment	Programmable on all the measuring range (see "Measuring variables and Min. Max. indications")	On-time delay	0 to 9999s (166min)
Hysteresis	programmable on all the measuring range (see "Measuring variables and Min. Max. indications")	Off-time delay	0 to 9999s (166min)
		Min. response time	≤ 1s, set-point on-time delay: "0 s"

Software functions

Password	Numeric code of max. 4 digits; 2 protection levels of the programming data: Password "0", no protection; Password from 1 to 9999, all data are protected	Displaying	1 variable per page (See «Measuring variables and Min. Max. indications»)
1st level		Reset	By means of the front key-pad: - W dmd max; - energies: kWh, kvarh
2nd level			

General specifications

Operating temperature	-25°C to +55°C (13°F to 131°F) (R.H. from 0 to 90% non-condensing @ 40°C) according to EN62053-21 and EN62053-23	Surge	On current and voltage measuring input circuits: 4kV;
Storage temperature	-30°C to +70°C (22°F to 140°F) (R.H. < 90% non-condensing @ 40°C) according to EN62053-21 and EN62053-23	Radio frequency suppression	According to CISPR 22
Installation category	Cat. III (IEC60664, EN60664)	Standard compliance	
Insulation (for 1 minute)	4000 VRMS between measuring inputs and digital output (O1 and R1).	Safety	IEC60664, IEC61010-1 EN60664, EN61010-1 EN62052-11
Dielectric strength	4000 VRMS for 1 minute	Metrology	EN62053-21, EN62053-23. MID "annex MI-003"
CMRR Noise rejection	100 dB, 48 to 62 Hz	Pulse output Approvals	DIN43864, IEC62053-31 CE, PTB (Revenue Approvals)
EMC	According to EN62052-11 8kV air discharge;	Connections	Screw-type
Electrostatic discharges	Test with applied current: 10V/m from 80 to 2000MHz;	Cable cross-section area	Min. 2.5 mm ² , Max. 10 mm ² (measuring inputs);
Immunity to irradiated electromagnetic fields	Test without any applied current: 30V/m from 80 to 2000MHz;		Other terminals: 1.5 mm ² Min./Max. screws tightening torque: 1 Nm / 4 Nm
Burst	On current and voltage measuring input circuits: 4kV	DIN Housing	
Immunity to conducted disturbances	10V/m from 150KHz to 80MHz	Dimensions (WxHxD)	17.5 (+0.5 -0) x 90 x 67.5 mm
		Material	Nylon PA66, self-extinguishing: UL 94 V-0
		Mounting	DIN-rail
		Protection degree	
		Front	IP40
		Screw terminals	IP20
		Weight	Approx. 100 g (packing included)

Power supply specifications

Self supplied version	120VLN, 230 VLN (-20% +20%) 48-62Hz	Power consumption	≤ 3VA
------------------------------	-------------------------------------	--------------------------	-------



Accuracy

kWh, accuracy (RDG) depending on the current

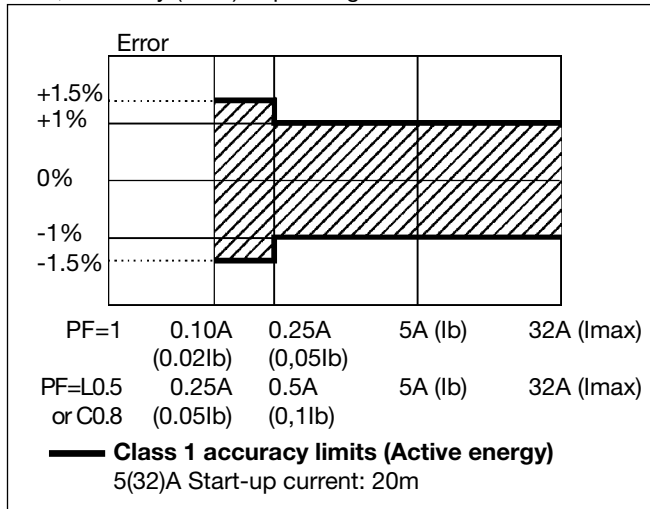

kvarh, accuracy (RDG) depending on the current

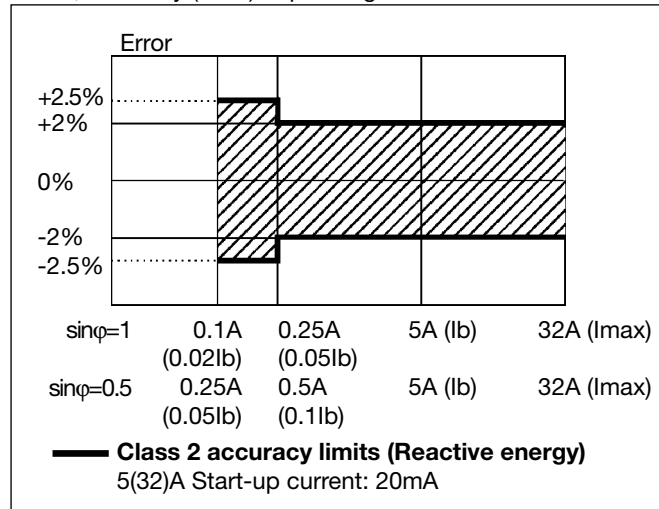

MID "Annex MI-003" compliance

Accuracy

0.9 Un ≤ U ≤ 1.1 Un;
0.98 fn ≤ f ≤ 1.02 fn;
fn: 50 or 60Hz;
cosφ: 0.5 inductive to 0.8
capacitive.
Class B
I st: 0.025A;
I min: 0.32A;
I tr: 0.64A;
I max: 32A.

Operating temperature

-25°C to +55°C (13°F to
131°F) (R.H. from 0 to 90%
non-condensing @ 40°C)

EMC compliance

E2

Used calculation formulas

Phase variables

Instantaneous effective voltage

$$V_{IN} = \sqrt{\frac{1}{n} \cdot \sum_{i=1}^n (V_{IN,i})^2}$$

Instantaneous active power

$$W_1 = \frac{1}{n} \cdot \sum_{i=1}^n (V_{IN,i}) \cdot (A_i)$$

Instantaneous power factor

$$\cos\phi_1 = \frac{W_1}{VA_1}$$

Instantaneous effective current

$$A_1 = \sqrt{\frac{1}{n} \cdot \sum_{i=1}^n (A_i)^2}$$

Instantaneous apparent power

$$VA_1 = V_{IN} \cdot A_1$$

Instantaneous reactive power

$$\text{var}_1 = \sqrt{(VA_1)^2 - (W_1)^2}$$

Where: n= sample number

Energy metering

$$kWh_1 = \int_{t_1}^{t_2} P_1(t) dt \cong \Delta t \sum_{j=n_1}^{n_2} P_1(j)$$

$$k \text{ var } h_1 = \int_{t_1}^{t_2} Q_1(t) dt \cong \Delta t \sum_{j=n_1}^{n_2} Q_1(j)$$

Where:

P= active power;

Q= reactive power;

t₁, t₂=starting and ending time points
of consumption recording;

nj= time unit;

Δt= time interval between two

successive power consumptions;

n₁, n₂ = starting and ending discrete
time points of consumption recording

Measuring variables and Min. Max. indications

Page number	Variable	Min. Max. Indication	Notes
1	kWh	from 0.0 to 99999.9	Total (only consumed energy)
2	kvarh	from 0.0 to 99999.9	Total (only consumed energy)
3	kW	from 0.00 to 9.99	
4	kW dmd	from 0.00 to 9.99	Integration time programmable from 1 to 30 minutes
5	kW dmd max	from 0.00 to 9.99	Max value with data storage (in EEPROM)
6	V	from 0.0 to 999.9	
7	A	from 0.0 to 32.00	
8	Hz	from 48.0 to 62.0	
9	PF (cosφ)	from L/C. 00 to L/C. 99	
10	kvar	from 0.00 to 9.99	

Insulation between inputs and outputs

	Measuring inputs	Relay output	Open collector output	AC self-power supply
Measuring inputs	-	4kV	4kV	0kV
Relay output	4kV	-	4kV	4kV
Open collector output	4kV	4kV	-	4kV
AC self-power supply	0kV	4kV	4kV	-

Wiring diagrams and relay output (R1)

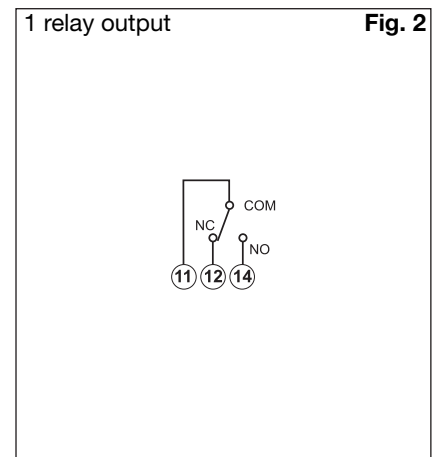
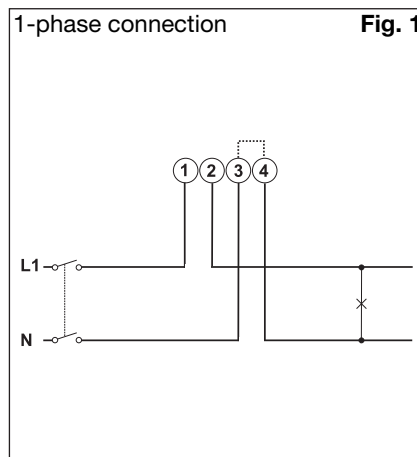

NOTE: The 3 and 4 terminals, in the instrument, are wired together

Wiring diagrams and open collector output (O1)

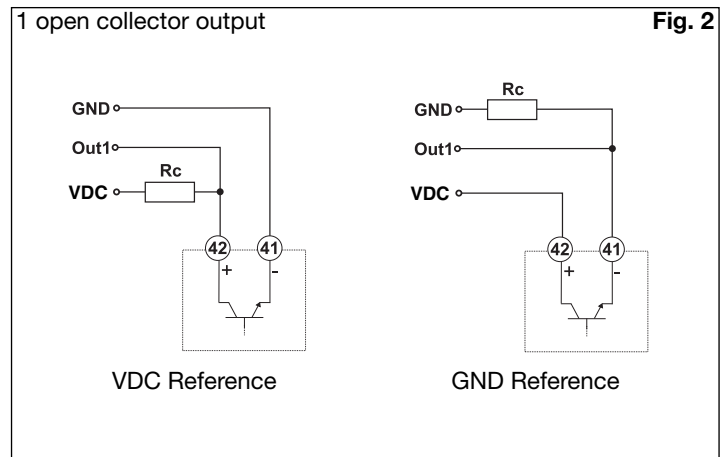
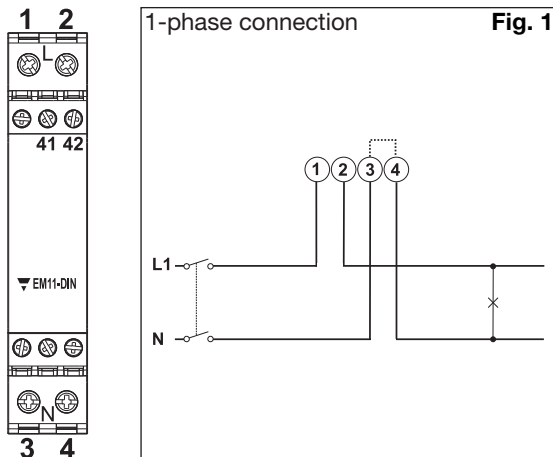

NOTE: The 3 and 4 terminals, in the instrument, are wired together

The load resistances (R_C) must be designed so that the close contact current is lower than 100mA; the VDC voltage must be lower than or equal to 30VDC.

Frontal panel description

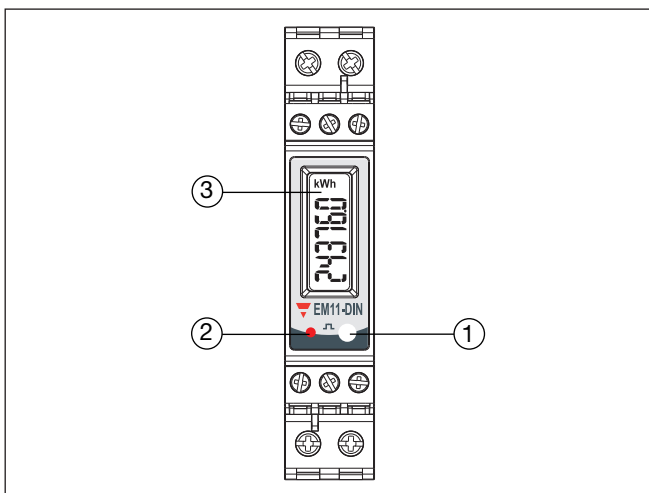

- 1. Push button**
To program the configuration parameters and the display of the variables.
- 2. LED**
Red LED to show the consumed energy.
- 3. Display**
LCD-type with alphanumeric indication to:
 - display configuration parameters;
 - display all the measured variables.

Dimensions and panel cut-out

