

1°C Triple Temperature Sensor with Resistance Error Correction

Datasheet

General Description

The EMC1023 is a System Management Bus (SMBus) temperature sensor that is capable of monitoring three temperature zones. Four unique part numbers can be ordered, each with a different SMBus Address. The three temperature zones consist of two external diodes and one internal monitor.

Extended features include resistance error correction and ideality factor configuration eliminating both major sources of temperature measurement error.¹ The 11-bit delta-sigma temperature-to-digital converter provides superb linearity, excellent noise immunity and repeatable temperature readings. An extended temperature format may be selected for compatibility with a broad range of CPUs. Selectable conversion rates and standby mode support low-power operation.

1. Patents pending

Features

- Resistance Error Correction
- Ideality Factor Configuration
- Accepts 2200pF cap for noise suppression
- Remote Thermal Zones
 - $\pm 1^\circ\text{C}$ Accuracy (40°C to 80°C)
 - 0.125°C resolution
- Internal Thermal Zone
 - $\pm 3^\circ\text{C}$ Accuracy (0°C to 85°C)
 - 0.125°C resolution
- Low Power; 3.0V to 3.6V Supply
- Four Unique SMBus Addresses Available
- Programmable Conversion Rate
- MSOP-8 3x3mm Lead-Free RoHS Compliant Package

Applications

- Desktop and Notebook Computers
- Thermostats
- Smart batteries
- Industrial/Automotive

Simplified Block Diagram

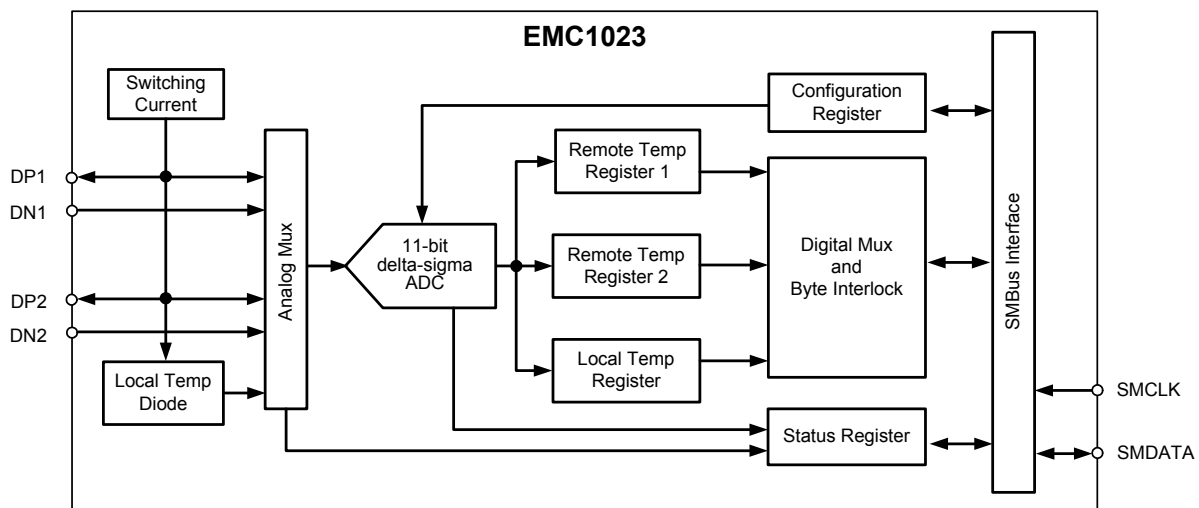

ORDER NUMBERS**EMC1023-1-ACZL-TR FOR 8 PIN, MSOP Lead-Free RoHS Compliant Package (Address - 1001100b)****EMC1023-2-ACZL-TR FOR 8 PIN, MSOP Lead-Free RoHS Compliant Package (Address - 1001101b)****EMC1023-3-ACZL-TR FOR 8 PIN, MSOP Lead-Free RoHS Compliant Package (Address - 1001000b)****EMC1023-4-ACZL-TR FOR 8 PIN, MSOP Lead-Free RoHS Compliant Package (Address - 1001001b)**

Reel size is 4,000 pieces.

Evaluation Board available upon request. (EVB-EMC1023)



80 ARKAY DRIVE, HAUPPAUGE, NY 11788 (631) 435-6000, FAX (631) 273-3123

Copyright © 2007 SMSC or its subsidiaries. All rights reserved.

Circuit diagrams and other information relating to SMSC products are included as a means of illustrating typical applications. Consequently, complete information sufficient for construction purposes is not necessarily given. Although the information has been checked and is believed to be accurate, no responsibility is assumed for inaccuracies. SMSC reserves the right to make changes to specifications and product descriptions at any time without notice. Contact your local SMSC sales office to obtain the latest specifications before placing your product order. The provision of this information does not convey to the purchaser of the described semiconductor devices any licenses under any patent rights or other intellectual property rights of SMSC or others. All sales are expressly conditional on your agreement to the terms and conditions of the most recently dated version of SMSC's standard Terms of Sale Agreement dated before the date of your order (the "Terms of Sale Agreement"). The product may contain design defects or errors known as anomalies which may cause the product's functions to deviate from published specifications. Anomaly sheets are available upon request. SMSC products are not designed, intended, authorized or warranted for use in any life support or other application where product failure could cause or contribute to personal injury or severe property damage. Any and all such uses without prior written approval of an Officer of SMSC and further testing and/or modification will be fully at the risk of the customer. Copies of this document or other SMSC literature, as well as the Terms of Sale Agreement, may be obtained by visiting SMSC's website at <http://www.smisc.com>. SMSC is a registered trademark of Standard Microsystems Corporation ("SMSC"). Product names and company names are the trademarks of their respective holders.

SMSC DISCLAIMS AND EXCLUDES ANY AND ALL WARRANTIES, INCLUDING WITHOUT LIMITATION ANY AND ALL IMPLIED WARRANTIES OF MERCHANTABILITY, FITNESS FOR A PARTICULAR PURPOSE, TITLE, AND AGAINST INFRINGEMENT AND THE LIKE, AND ANY AND ALL WARRANTIES ARISING FROM ANY COURSE OF DEALING OR USAGE OF TRADE. IN NO EVENT SHALL SMSC BE LIABLE FOR ANY DIRECT, INCIDENTAL, INDIRECT, SPECIAL, PUNITIVE, OR CONSEQUENTIAL DAMAGES; OR FOR LOST DATA, PROFITS, SAVINGS OR REVENUES OF ANY KIND; REGARDLESS OF THE FORM OF ACTION, WHETHER BASED ON CONTRACT; TORT; NEGLIGENCE OF SMSC OR OTHERS; STRICT LIABILITY; BREACH OF WARRANTY; OR OTHERWISE; WHETHER OR NOT ANY REMEDY OF BUYER IS HELD TO HAVE FAILED OF ITS ESSENTIAL PURPOSE, AND WHETHER OR NOT SMSC HAS BEEN ADVISED OF THE POSSIBILITY OF SUCH DAMAGES.

Chapter 1 Pin Configuration

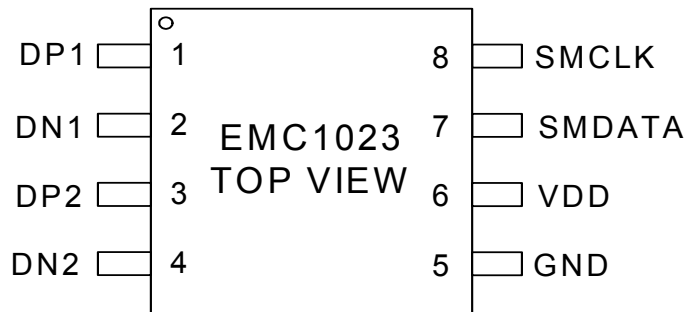

Figure 1.1 EMC1023 Pin Configuration

Table 1.1 Pin Description

PIN	PIN NO.	DESCRIPTION
DP1	1	Positive Analog Input for External Temperature Diode 1
DN1	2	Negative Analog Input for External Temperature Diode 1
DP2	3	Positive Analog Input for External Temperature Diode 2
DN2	4	Negative Analog Input for External Temperature Diode 2
GND	5	Ground
VDD	6	Supply Voltage
SMDATA	7	System Management Bus Data Input/Output, open drain output
SMCLK	8	System Management Bus Clock Input

Table 1.2 Absolute Maximum Ratings

DESCRIPTION	RATING	UNIT
Supply Voltage V_{DD}	-0.3 to 5.0	V
Voltage on SMDATA and SMCLK pins	-0.3 to 5.5	V
Voltage on any other pin	-0.3 to $V_{DD}+0.3$	V
Operating Temperature Range	0 to 85	°C
Storage Temperature Range	-55 to 150	°C
Lead Temperature Range	Refer to JEDEC Spec. J-STD-020	
Package Thermal Characteristics for MSOP-8		
Power Dissipation	TBD	
Thermal Resistance (at 0 air flow)	135.9	°C/W
ESD Rating, All Pins Human Body Model	2000	V

Note: Stresses above those listed could cause damage to the device. This is a stress rating only and functional operation of the device at any other condition above those indicated in the operation sections of this specification is not implied. When powering this device from laboratory or system power supplies, it is important that the Absolute Maximum Ratings not be exceeded or device failure can result. Some power supplies exhibit voltage spikes on their outputs when the AC power is switched on or off. In addition, voltage transients on the AC power line may appear on the DC output. If this possibility exists, it is suggested that a clamp circuit be used.

Chapter 2 Electrical Characteristics

Table 2.1 Electrical Characteristics

V _{DD} =3.0V to 3.6V, T _A = 0°C to +85°C, Typical values at T _A = 27°C unless otherwise noted						
PARAMETER	SYMBOL	MIN	TYP	MAX	UNITS	CONDITIONS
DC Power						
Supply Voltage	V _{DD}	3.0	3.3	3.6	V	
Average Operating Current	I _{DD}		36	42	μA	1 conversions/s
	I _{PD}		2	4	μA	Standby mode
Internal Temperature Monitor						
Temperature Accuracy			±1	±3	°C	0°C ≤ T _A ≤ 85°C
Temperature Resolution			0.125		°C	
External Temperature Monitor						
Temperature Accuracy Remote Diode 40°C to 80°C Remote Diode 0°C to 125°C				±1 ±3	°C °C	15°C ≤ T _A ≤ 70°C 0°C ≤ T _A ≤ 85°C
Temperature Resolution			0.125		°C	
ADC						
Conversion Time for all three sensors			62		ms	
Wake-up from STOP mode (During one shot command or transition to RUN mode)				1	ms	
Voltage Tolerance (SMDATA, SMCLK)						
Voltage at pin	V _{TOL}	-0.3		5.5	V	
SMBus Interface (SMDATA, SMCLK)						
Input High Level	V _{IH}	2.0			V	
Input Low Level	V _{IL}			0.8	V	
Input High/Low Current	I _{IH} /I _{IL}	-1		1	μA	
Hysteresis			500		mV	
Input Capacitance			5		pF	
Output Low Sink Current		6			mA	SMDATA = 0.6V
SMBus Timing						
Clock Frequency	F _{SMB}	10		400	kHz	
Spike Suppression				50	ns	
Bus free time Start to Stop	T _{BUF}	1.3			μs	
Hold time Start	T _{HD:STA}	0.6			μs	

Table 2.1 Electrical Characteristics (continued)

V _{DD} =3.0V to 3.6V, T _A = 0°C to +85°C, Typical values at T _A = 27°C unless otherwise noted						
PARAMETER	SYMBOL	MIN	TYP	MAX	UNITS	CONDITIONS
Setup time Start	T _{SU:STA}	0.6			μs	
Setup time Stop	T _{SU:STO}	0.6			μs	
Data Hold Time	T _{HD:DAT}	0.3			μs	
Data Setup Time	T _{SU:DAT}	100			ns	
Clock Low Period	T _{LOW}	1.3			μs	
Clock High Period	T _{HIGH}	0.6			μs	
Clock/Data Fall Time	T _F	*		300	ns	*Min = 20+0.1C _b ns
Clock/Data Rise Time	T _R	*		300 Note 2.1	ns	*Min = 20+0.1C _b ns
Capacitive Load (each bus line)	C _b	0.6		400	pF	

Note 2.1 300nS rise time max is required for 400kHz bus operation. For lower clock frequencies, the maximum rise time is (0.1/F_{SMB})+50nS

Chapter 3 System Management Bus Interface Protocol

A host controller, such as an SMSC I/O controller, communicates with the EMC1023 via the two wire serial interface named SMBus. The SMBus interface is used to read and write registers in the EMC1023, which is a slave-only device. A detailed timing diagram is shown in [Figure 3.1](#).

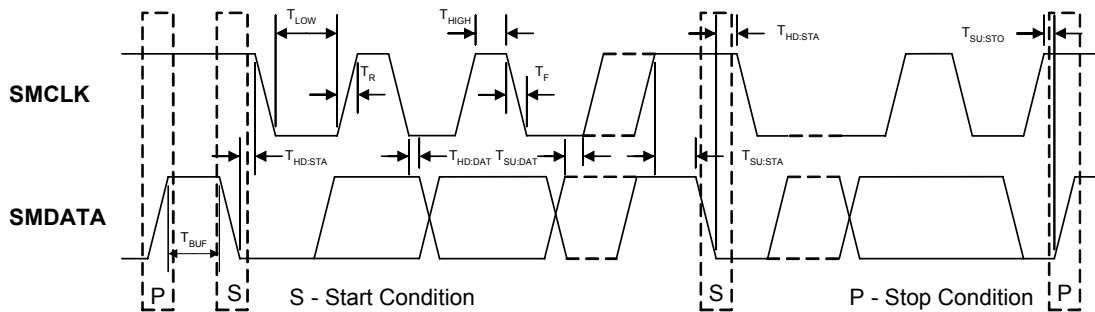

Figure 3.1 System Management Bus Timing Diagram

The EMC1023 implements a subset of the SMBus specification and supports Write Byte, Read Byte, Send Byte, Receive Byte, and Alert Response Address protocols. as shown. In the tables that describe the protocol, the “gray” columns indicate that the slave is driving the bus.

3.1 Write Byte

The Write Byte protocol is used to write one byte of data to the registers as shown below:

Table 3.1 SMBus Write Byte Protocol

START	SLAVE ADDRESS	WR	ACK	COMMAND	ACK	DATA	ACK	STOP
1	7	1	1	8	1	8	1	1

3.2 Read Byte

The Read Byte protocol is used to read one byte of data from the registers as shown below:

Table 3.2 SMBus Read Byte Protocol

START	SLAVE ADDRESS	WR	ACK	COMMAND	ACK	START	SLAVE ADDRESS	RD	ACK	DATA	NACK	STOP
1	7	1	1	8	1	1	7	1	1	8	1	1

3.3 Send Byte

The Send Byte protocol is used to set the Internal Address Register to the correct Address. The Send Byte can be followed by the Receive Byte protocol described below in order to read data from the register. The send byte protocol cannot be used to write data - if data is to be written to a register then the write byte protocol must be used as described in subsection above. The send byte protocol is shown in [Table 3.3](#), “SMBus Send Byte Protocol,” on page 7.

Table 3.3 SMBus Send Byte Protocol

FIELD:	START	SLAVE ADDR	WR	ACK	REG. ADDR	ACK	STOP
Bits:	1	7	1	1	8	1	1

3.4 Receive Byte

The Receive Byte protocol is used to read data from a register when the internal register address pointer is known to be at the right location (e.g. set via Send Byte). This can be used for consecutive reads of the same register as shown below:

Table 3.4 SMBus Receive Byte Protocol

FIELD:	START	SLAVE ADDR	RD	ACK	REG. DATA	NACK	STOP
Bits:	1	7	1	1	8	1	1

3.5 SMBus Addresses

The EMC1023 may be ordered with one of four 7-bit slave addresses as shown in [Order Numbers](#). Attempting to communicate with the EMC1023 SMBus interface with an invalid slave address or invalid protocol results in no response from the device and does not affect its register contents. The EMC1023 supports stretching of the SMCLK signal by other devices on the SMBus but will not perform this operation itself.

3.6 SMBus Timeout

The EMC1023 includes an SMBus timeout feature. Following a 25 ms period of inactivity on the SMBus, the device will timeout and reset the SMBus interface.

Chapter 4 Product Description

The EMC1023 is an SMBus sensor that is capable of monitoring three temperature zones for use in a personal computer or embedded environment. The part may be used as a companion to one of SMSC's broad line of SIO host circuits, or other devices capable of performing the SMBus host function.

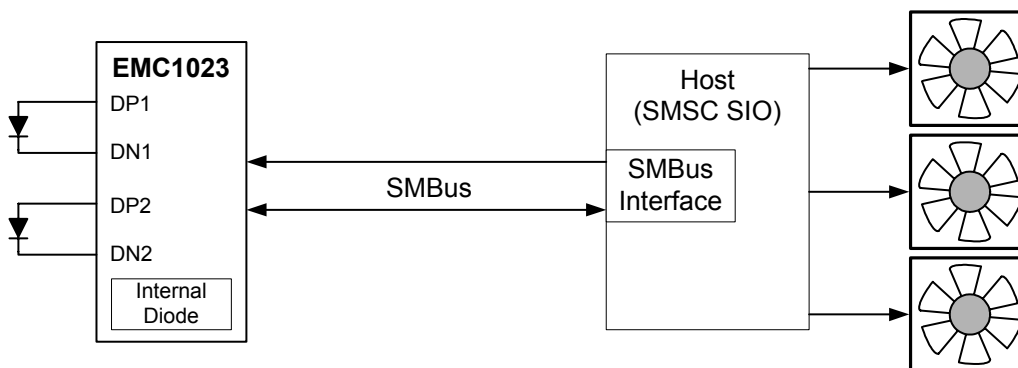

Figure 4.1 System Overview

In cooperation with the host device, thermal management can be performed as outlined in [Figure 4.1](#) above. Thermal management consists of the host reading the temperature data from the remote and internal temperature diodes of the EMC1023 and controlling the speed of one or multiple fans. Since the EMC1023 incorporates one internal and two external temperature diodes, three separate thermal zones can be monitored and controlled with this application. Also, measured temperature levels can quickly be compared to preset limits within the host device which in turn will take the appropriate action when values are found to be out of limit.

The EMC1023 has two basic modes of operation:

- **Run Mode:** In this mode, the EMC1023 continuously converts temperature data and updates its registers. The conversion rate is configured by the lower bits in the configuration register as described in [Section Table 4.8, "Configuration Register, Conversion Rate," on page 14](#).
- **Standby Mode:** In this mode, the EMC1023 is powered down, drawing a maximum current of only 3uA. The SMBus is still operational and a one-shot command can be given which will force the circuit to complete one full set of temperature conversions. The EMC1023 will return to Standby Mode after the one shot conversion has finished.

4.1 Temperature Monitors

Thermal diode temperature measurements are based on the change in forward bias voltage (ΔV_{BE}) of a diode when operated at two different currents:

$$\Delta V_{BE} = V_{BE_HIGH} - V_{BE_LOW} = \frac{\eta k T}{q} \ln \left(\frac{I_{HIGH}}{I_{LOW}} \right)$$

where:

k = Boltzmann's constant

T = absolute temperature in Kelvin

q = electron charge

η = diode ideality factor

The change in ΔV_{BE} voltage is proportional to absolute temperature T .

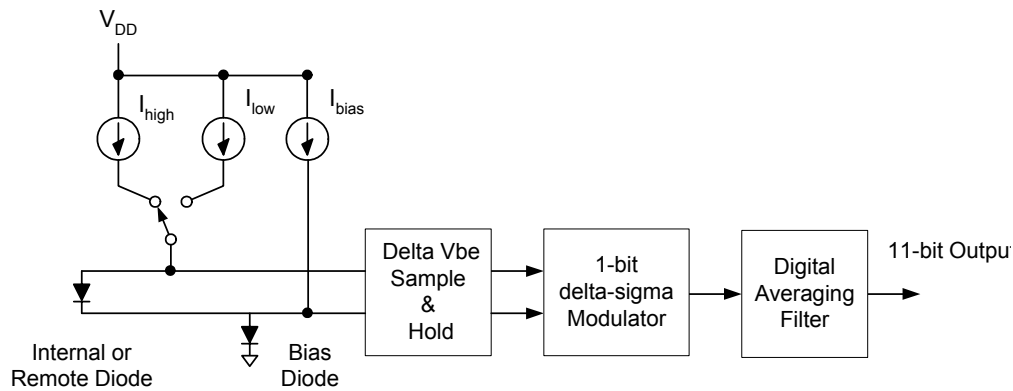

Figure 4.2 Detailed Block Diagram

Figure 4.2 shows a detailed block diagram of the temperature measurement circuit. The EMC1023 incorporates switched capacitor technology that integrates the temperature diode ΔV_{BE} from different bias currents. The negative terminal, DN, for the temperature diode is internally biased with a forward diode voltage referenced to ground.

The advantages of this architecture over Nyquist rate FLASH or SAR converters are superb linearity and inherent noise immunity. The linearity can be directly attributed to the delta-sigma ADC single-bit comparator while the noise immunity is achieved by the $\sim 20\text{ms}$ integration time which translates to 50Hz input noise bandwidth.

The 11 bit conversion can be displayed in either legacy format or in extended range format. In Legacy format, the temperature range covers -64°C to 127°C while in extended format, temperature readings span -64°C to 191°C . It should be noted that the latter range is really meant to cover thermal diodes with a non ideal curvature caused by factor n in equation (1) not being equal to exactly 1.000. In general, it is not recommended to run silicon based thermal diodes at temperatures above 150°C .

4.2 Resistance Error Correction

The EMC1023 includes resistance error correction implemented in the analog front end of the chip. Without this automatic feature, voltage developed across the parasitic resistance in the remote diode path causes the temperature to read higher than the true zone temperature. The error introduced by parasitic resistance is approximately $+0.7^\circ\text{C}$ per ohm. Sources of parasitic resistance include bulk resistance in the remote temperature transistor junctions along with resistance in the printed circuit board traces and package leads.

Resistance error correction in the EMC1023 eliminates the need to characterize and compensate for parasitic resistance in the remote diode path.

4.3 Programmable Ideality Factor Configuration

Temperature sensors like the EMC1023 are typically designed for remote diodes with an ideality factor of 1.008. When the diode does not have this exact factor, an error is introduced in the temperature measurement. Programmable offset registers are sometimes used to compensate for this error, but this correction is only perfect at one temperature since the error introduced by ideality factor mismatch is a function of temperature. The higher the temperature measured, the greater the error introduced. To provide maximum flexibility to the user, the EMC1023 provides a 6-bit ideality factor register for each remote diode. The ideality factor of the remote diode is programmed in these registers to eliminate errors across all temperatures. See [Section 4.10, "Ideality Factor Register," on page 15](#) for details on programming these registers.

4.4 Register Allocation

See [Table 4.1, "Register Table,"](#) on page 11 for a description of registers that are accessible through the SMBus:

Table 4.1 Register Table

READ ADDRESS (HEX)	WRITE ADDRESS (HEX)	REGISTER NAME	DEFAULT VALUE (HEX)
00	N/A	Legacy Format Internal Temperature High Byte	00
23	N/A	Legacy Format Internal Temperature Low Byte	00
01	N/A	Legacy Format Remote Temperature 1 High Byte	00
10	N/A	Legacy Format Remote Temperature 1 Low Byte	00
F8	N/A	Legacy Format Remote Temperature 2 High Byte	00
F9	N/A	Legacy Format Remote Temperature 2 Low Byte	00
FA	N/A	Extended Format Remote Temperature 1 High Byte	00
FB	N/A	Extended Format Remote Temperature 1 Low Byte	00
FC	N/A	Extended Format Remote Temperature 2 High Byte	00
FD	N/A	Extended Format Remote Temperature 2 Low Byte	00
02	N/A	Status register	00
03	09	Configuration register	47
N/A	0F	One Shot Command	--
27	27	Remote 1 Ideality Factor	12
28	28	Remote 2 Ideality Factor	12
ED	N/A	Product ID	04 (-1) 05 (-2) 06 (-3) 07 (-4)
FE	N/A	Manufacturer ID	5D
FF	N/A	Revision Number	01

During Power on Reset (POR), the default values are stored in the registers. A POR is initiated when power is first applied to the part and the voltage on the VDD supply surpasses the POR level as specified in the electrical characteristics. Any reads to undefined registers will return 00h. Writes to any undefined registers will not have an effect.

The EMC1023 uses an interlock mechanism that prevents changes in register content when fresh readings come in from the ADC during successive reads from a host. When the High Byte is read, the last conversion value is latched into the High Byte and Low Byte. Please note that the interlock mechanism is only effective when reading the High Byte first.

4.5 Temperature Monitor Registers

As shown in [Table 4.1](#), each temperature monitor has two byte wide data registers. The external monitors are equipped with both legacy and extended data format. The 11 bit data temperature is stored aligned to the left resulting in the High Byte to contain temperature in 1°C steps and the Low Byte to contain fractions of °C as outlined below:

Table 4.2 High Byte Temperature Register

REGISTER	BIT 7	BIT 6	BIT 5	BIT 4	BIT 3	BIT 2	BIT 1	BIT 0
Temperature High Byte Registers 00h, 01h, F8h, FAh, FCh	SIGN	64	32	16	8	4	2	1

Table 4.3 Low Byte Temperature Register

REGISTER	BIT 7	BIT 6	BIT 5	BIT 4	BIT 3	BIT 2	BIT 1	BIT 0
Temperature Low Byte Registers 23h, 10h, F9h, FBh, FDh	0.500	0.250	0.125	0	0	0	0	0

4.6 Legacy Temperature Data Format Registers 00h, 23h, 01h, 10h, F8h, F9h:

For registers displaying legacy temperature data format, the temperature range spans from -63.875°C to +127.875°C with 0.125°C resolution. Temperatures outside this range are clipped to -63.875°C and +127.875°C. Data is stored in the registers in 2's complement as shown in [Table 4.4](#):

Table 4.4 Legacy Temperature Data Format

TEMPERATURE (°C)	2'S COMPLEMENT	HEX
Diode Fault	100 0000 0000	400
= -63.875	110 0000 0001	601
-63	110 0000 1000	608
-1	111 1111 1000	7F8
0	000 0000 0000	000
+0.125	000 0000 0001	001
+1	000 0000 1000	008
+127	011 1111 1000	3F8
≥ +127.875	011 1111 1111	3FF

4.7 Extended Temperature Data Format Registers FAh, FBh, FCh, FDh

For registers displaying extended temperature data format, a value of 64d is subtracted from the Legacy Format output. This effectively extends the range to cover higher external temperature measurements while still maintaining the 2's complement format. Obviously, the host will have to compensate and add 64d to the read temperature data. This format spans from -63.875°C to $+191.875^{\circ}\text{C}$ with 0.125°C resolution. Temperatures outside this range are limited to -63.875°C and $+191.875^{\circ}\text{C}$. [Table 4.5](#) shows example temperature readings and register content for this data format.

Table 4.5 Extended Temperature Data Format

ACTUAL TEMP. (°C)	-64°C OFFSET (°C)	2'S COMPLEMENT OF -64°C OFFSET	HEX
Diode Fault		100 0000 0000	400
= -63.875	-127.875	100 0000 0001	401
-63	-127	100 0000 1000	408
-1	-65	101 1111 1000	5F8
0	-64	110 0000 0000	600
+0.125	-63.875	110 0000 0001	601
+1	-63	110 0000 1000	608
+63	-1	111 1111 1000	7F8
+64	0	000 0000 0000	000
+65	1	000 0000 1000	008
+191	127	011 1111 1000	3F8
= +191.875	127.875	011 1111 1111	3FF

[Table 4.4](#) and [Table 4.5](#) show that temperature data is stored in 2's complement in both Legacy and Extended Temperature Data Format. Both extended and legacy temperature formats are updated simultaneously after every conversion cycle. Code 400h is reserved for diode fault signaling which occurs when open or short conditions are present between the external DP and DN pins.

4.8 Status Register

Table 4.6 Status Register

REGISTER	BIT 7	BIT 6	BIT 5	BIT 4	BIT 3	BIT 2	BIT 1	BIT 0	DEF
Status	Busy	-	-	-	-	-	D2	D1	00h

The Status register is a read only register and returns the operational status of the part. It indicates an external diode fault conditions through bit 0 and 1. When either D1 or D2 is set, a faulty diode connection is detected for external diode 1 or external diode 2 respectively. Also, when diode faults are detected, temperature readings for the faulty external diode will return 400h. The EMC1023 detects both open and short conditions for all diode pins. Bit 7 of the status register will be set when the internal ADC is busy converting data.

4.9 Configuration Register

Table 4.7 Configuration Register

REGISTER	BIT 7	BIT 6	BIT 5	BIT 4	BIT 3	BIT 2	BIT 1	BIT 0	DEF
Configuration	-	nRun/Stop	-	-	-	CR2	CR1	CR0	47h

Bits 0 through bit 2 of the configuration register set the ADC conversion rate of the part. See [Table 4.8, "Configuration Register, Conversion Rate,"](#) on page 14

Table 4.8 Configuration Register, Conversion Rate

CR2, CR1, CR0	CONVERSION RATE
000	Reserved
001	Reserved
010	Reserved
011	1 Conversions per second
100	2 Conversions per second
101	4 Conversions per second
110	8 Conversions per second
111	16 Conversions per second

A conversion for all 3 temperature readings takes about 60ms. Therefore, the maximum conversion rate, equals 16 conversions per second.

Bits 6 set of the Configuration Register sets the power mode of the part:

Table 4.9 Configuration Registers Data Format

NRUN/STOP	DESCRIPTION
0	Run Mode
1	Standby Mode

In Run Mode, the EMC1023 will operate at the preset conversion rate. In Standby Mode, the part is powered down to minimize current consumption. The SMBus is fully operational in either mode. In Standby Mode, a WRITE command to the One Shot register will trigger a one time conversion of the 3 temperature monitors. After the part finishes the conversion, it will go back to Standby Mode. The host can now read the updated temperature information.

4.10 Ideality Factor Register

The ideality factor registers are used to program the remote diode ideality factor into the EMC1023 so that this error source can be eliminated. The default ideality factor is 1.008 and has a value of XX010010b or 12h.

Table 4.10 Diode Ideality Factor Values

DIODE IDEALITY FACTOR	VALUE	DIODE IDEALITY FACTOR	VALUE	DIODE IDEALITY FACTOR	VALUE	DIODE IDEALITY FACTOR	VALUE
0.9850	XX00 0000	1.0054	XX01 0000	1.0267	XX10 0000	1.0489	XX11 0000
0.9862	XX00 0001	1.0067	XX01 0001	1.0280	XX10 0001	1.0503	XX11 0001
0.9875	XX00 0010	1.0080	XX01 0010	1.0294	XX10 0010	1.0517	XX11 0010
0.9888	XX00 0011	1.0093	XX01 0011	1.0308	XX10 0011	1.0531	XX11 0011
0.9900	XX00 0100	1.0106	XX01 0100	1.0321	XX10 0100	1.0546	XX11 0100
0.9913	XX00 0101	1.0119	XX01 0101	1.0335	XX10 0101	1.0560	XX11 0101
0.9925	XX00 0110	1.0133	XX01 0110	1.0349	XX10 0110	1.0574	XX11 0110
0.9938	XX00 0111	1.0146	XX01 0111	1.0363	XX10 0111	1.0589	XX11 0111
0.9951	XX00 1000	1.0159	XX01 1000	1.0377	XX10 1000	1.0603	XX11 1000
0.9964	XX00 1001	1.0173	XX01 1001	1.0391	XX10 1001	1.0618	XX11 1001
0.9976	XX00 1010	1.0186	XX01 1010	1.0404	XX10 1010	1.0632	XX11 1010
0.9989	XX00 1011	1.0199	XX01 1011	1.0418	XX10 1011	1.0647	XX11 1011
1.0002	XX00 1100	1.0213	XX01 1100	1.0432	XX10 1100	1.0661	XX11 1100
1.0015	XX00 1101	1.0226	XX01 1101	1.0446	XX10 1101	1.0676	XX11 1101
1.0028	XX00 1110	1.0240	XX01 1110	1.0460	XX10 1110	1.0690	XX11 1110
1.0041	XX00 1111	1.0253	XX01 1111	1.0475	XX10 1111	1.0705	XX11 1111

Chapter 5 Application Information

This chapter provides information on maintaining accuracy when using diodes as remote sensors with SMSC Environmental Monitoring and Control devices. It is assumed that the users have some familiarity with hardware design and transistor characteristics.

SMSC supplies a family Environmental Monitoring and Control (EMC) devices that are capable of accurately measuring temperatures. Most devices include an internal temperature sensor along with the ability to measure one or more external sensors. The characteristics of an appropriate diode for use as the external sensor are listed in this chapter. Recommendations for the printed circuit board layout are provided to help reduce error caused by electrical noise or trace resistance.

5.1 Maintaining Accuracy

5.1.1 Physical Factors

Temperature measurement is performed by measuring the change in forward bias voltage of a diode when different currents are forced through the junction. The circuit board itself can impact the ability to accurately measure these small changes in voltage.

5.1.1.1 Layout

Apply the following guidelines when designing the printed circuit board:

1. Route the remote diode traces on the top layer.
2. Place a ground guard signal on both sides of the differential pair. This guard band should be connected to the ground plane at least every 0.25 inches.
3. Place a ground plane on the layer immediately below the diode traces.
4. Keep the diode traces as short as possible.
5. Keep the diode traces parallel, and the length of the two traces identical within 0.3 inches.
6. Use a trace width of 0.01 inches with a 0.01 inch guard band on each side.
7. Keep the diode traces away from sources of high frequency noise such as power supply filtering or high speed digital signals.
8. When the diode traces must cross high speed digital signals, make them cross at a 90 degree angle.
9. Avoid joints of copper to solder that can introduce thermocouple effects.

These recommendations are illustrated in [Figure 5.1 Routing the Diode Traces on page 17](#).

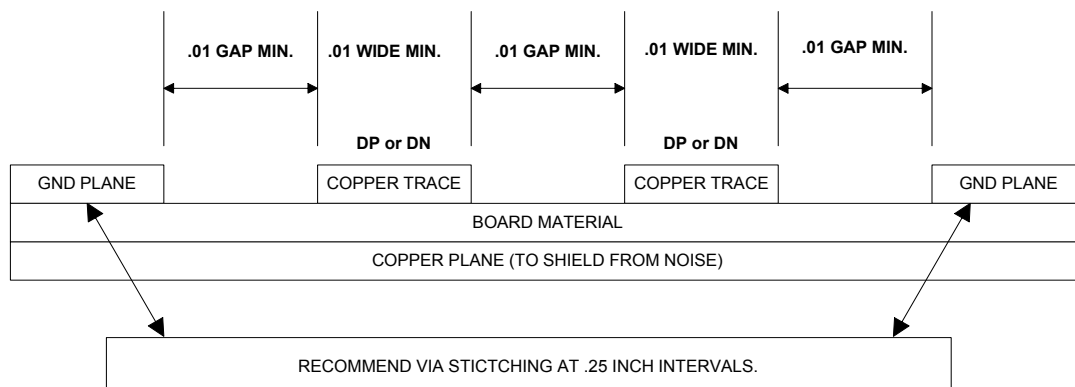

Figure 5.1 Routing the Diode Traces**5.1.1.2 Bypass Capacitors**

Accurate temperature measurements require a clean, stable power supply. Locate a 0.1 μ F capacitor as close as possible to the power pin with a good ground. A low ESR capacitor (such as a 10 μ F ceramic) should be placed across the power source. Add additional power supply filtering in systems that have a noisy power supply.

A capacitor may be placed across the DP/DN pair at the remote sensor in noisy environments. Do not exceed a value of 2.2nF if this capacitor is installed.

5.1.1.3 Manufacturing

Circuit board assembly processes may leave a residue on the board. This residue can result in unexpected leakage currents that may introduce errors if the circuit board is not clean. For example, processes that use water-soluble soldering fluxes have been known to cause problems if the board is not kept clean.

5.1.1.4 Thermal Considerations

Keep the sensor in good thermal contact with the component to be measured. The temperature of the leads of a discrete diode will greatly impact the temperature of the diode junction. Make use of the printed circuit board to disperse any self-heating that may occur.

5.1.1.5 Remote Sensors Connected by Cables

When connecting remote diodes with a cable (instead of traces on the PCB) use shielded twisted pair cable. The shield should be attached to ground near the EMC1023, and should be left unconnected at the sensor end. Belden 8451 cable is a good choice for this application.

5.1.2 Sensor Characteristics

The characteristics of the diode junction used for temperature sensing will affect the accuracy of the measurement.

5.1.2.1 Selecting a Sensor

A diode connected small signal transistor is recommended. Silicon diodes are not a good choice for remote sensors. Small signal transistors such as the 2N3904 or the 2N3906 are recommended. Select a transistor with a constant value of h_{FE} in the range of 2.5 to 220 microamps. The magnitude of h_{FE} is not critical, and the variation in h_{FE} from one device to another cancels out of the temperature equations.

5.1.2.2 Compensating for Ideality of the diode

The remote diode may have an ideality factor based on the manufacturing process. Inaccuracy in the temperature measurement resulting from this ideality factor may be eliminated by configuring the ideality factor register. The EMC1023 is trimmed to an ideality factor of 1.008.

5.1.2.3 Circuit Connections

The more negative terminal for the remote temperature diode, DN, is internally biased with a forward diode voltage. Terminal DN is not referenced to ground. Remote temperature diodes can be constructed as shown in [Figure 5.2 Remote Temperature Diode Examples on page 18](#).

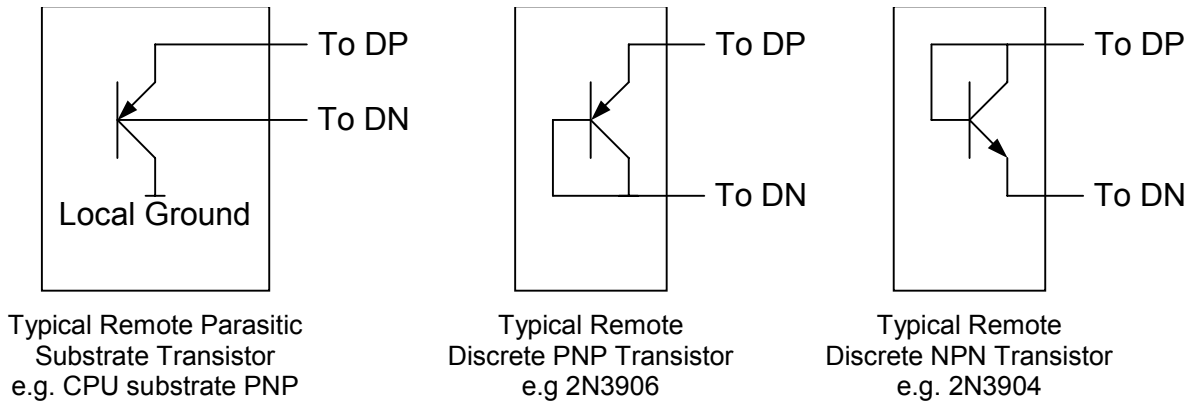

Figure 5.2 Remote Temperature Diode Examples

Environmental Monitoring and Control (EMC) devices supplied by SMSC are designed to make accurate temperature measurements. Careful design of the printed circuit board and proper selection of the remote sensing diode will help to maintain the accuracy.

Chapter 6 Package Outline

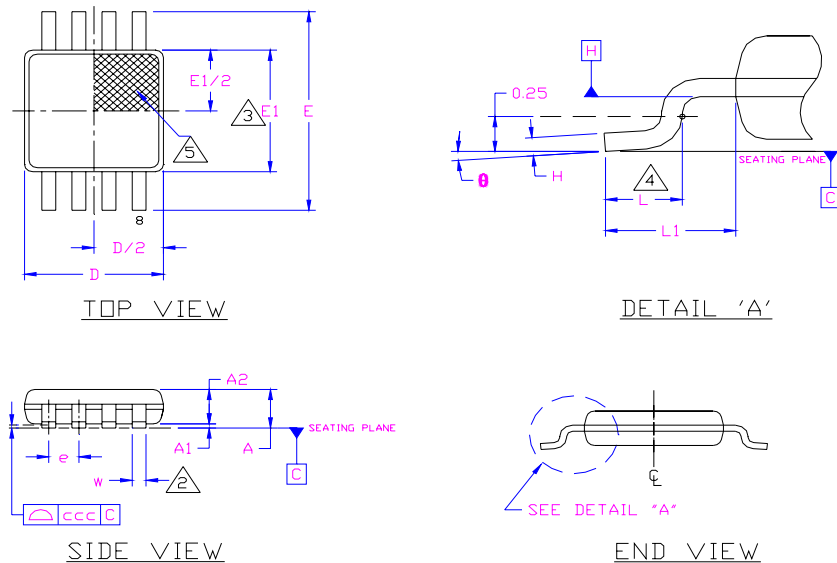

Figure 6.1 8-Pin MSOP Package Outline - 3x3mm Body 0.65mm Pitch

Table 6.1 8-Pin MSOP Package Parameters

	MIN	NOMINAL	MAX	REMARKS
A	0.80	~	1.10	Overall Package Height
A1	0.05	~	0.15	Standoff
A2	0.75	0.85	0.95	Body Thickness
D	2.80	3.00	3.20	X Body Size
E	4.65	4.90	5.15	Y Span
E1	2.80	~	3.20	Y body Size
H	0.08	~	0.23	Lead Foot Thickness
L	0.40	~	0.80	Lead Foot Length
L1	0.95 REF			Lead Length
e	0.65 BSC			Lead Pitch
θ	0°	~	8°	Lead Foot Angle
W	0.22	~	0.38	Lead Width
ccc	~	~	0.10	Coplanarity

Notes:

- Controlling Unit: millimeters.
- Tolerance on the true position of the leads is ± 0.065 mm maximum.
- Package body dimensions D and E1 do not include mold protrusion or flash. Dimensions D and E1 to be determined at datum plane H. Maximum mold protrusion or flash is 0.15mm (0.006 inches) per end, and 0.15mm (0.006 inches) per side.
- Dimension for foot length L measured at the gauge plane 0.25 mm above the seating plane.
- Details of pin 1 identifier are optional but must be located within the zone indicated.