

T-41-69

IS437/IS438 Built-in Amp. Type Opic Light Detector

■ Features

1. Built-in Schmidt trigger circuit
2. High sensitivity (E_v : MAX. 35 ℓx at $T_a=25^\circ C$)
3. LSTTL and TTL compatible output.
4. Open collector output
5. Low level output at light incident light (IS437)
High level output at incident light (IS438)

■ Applications

1. Floppy disk drives
2. Copiers, printers, facsimiles
3. VCRs, cassette tape recorder
4. Automatic vending machines

■ Outline Dimensions (Unit : mm)

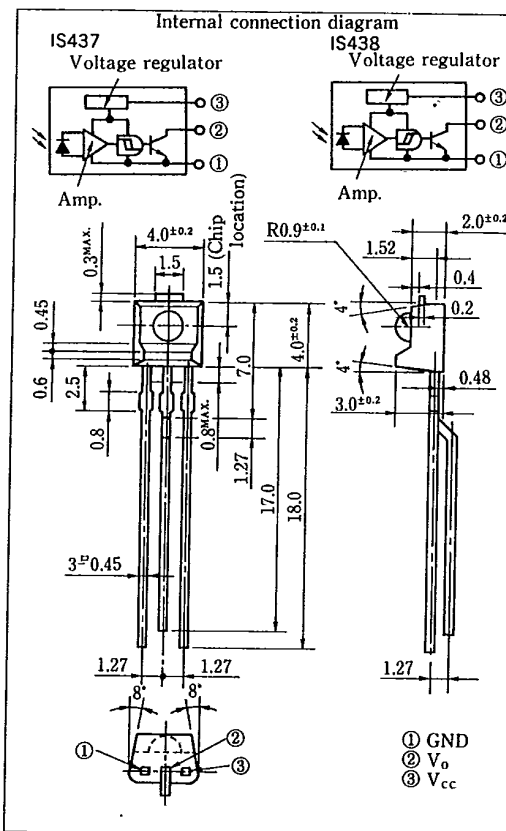

*OPIC is a registered trademark of Sharp and stands for Optical IC. It has a light detecting element and signal processing circuitry integrated onto a single chip.

■ Absolute Maximum Ratings (Ta=25°C)

Parameter	Symbol	Rating	Unit
Supply voltage	V_{cc}	-0.5 ~ +35	V
Output voltage	V_o	-0.5 ~ +40	V
Output current	I_o	50	mA
Power dissipation	P	250	mW
Operating temperature	T_{opr}	-25 ~ +85	°C
Storage temperature	T_{stg}	-40 ~ +100	°C
*Soldering temperature	T_{sol}	260	°C

*1 For 5 seconds at the position of 2.5mm from the bottom face of resin package.

SHARP

Electro-optical Characteristics

(Unless otherwise specified, $T_a=0\sim 70^\circ\text{C}$, $V_{cc}=5\text{V}$)

Parameter	Symbol	Conditions	MIN.	TYP.	MAX.	Unit		
Operating supply voltage	V_{cc}	$T_a=25^\circ\text{C}$	4.5	—	35	V		
Low level output voltage	V_{ol}	$I_{ol}=16\text{mA}^{*2}$	—	0.15	0.4	V		
Low level output current	I_{oh}	$V_{cc}=20\text{V}$, $V_o=30\text{V}^{*3}$	—	—	100	μA		
Low level supply current	I_{ccl}	$*2$	—	2.0	4.5	mA		
High level supply current	I_{cch}	$*3$	—	1.0	3.0	mA		
**"High"→"Low" threshold illuminance	IS437	E_{vhl}	$T_a=25^\circ\text{C}$, $R_L=280\Omega$	—	15	35	ℓ_x	
			$R_L=280\Omega$	—	—	50		
	IS438	$T_a=25^\circ\text{C}$, $R_L=280\Omega$	1.5	10	—			
		$R_L=280\Omega$	1	—	—			
***"Low"→"High" threshold illuminance	IS437	E_{vlh}	$T_a=25^\circ\text{C}$, $R_L=280\Omega$	1.5	10	—	ℓ_x	
			$R_L=280\Omega$	1	—	—		
	IS438	$T_a=25^\circ\text{C}$, $R_L=280\Omega$	—	15	35			
		$R_L=280\Omega$	—	—	50			
*6 Hysteresis	IS437	E_{vlh}/E_{vhl}	$T_a=25^\circ\text{C}$, $R_L=280\Omega$	0.50	0.65	0.90	—	
	IS438	E_{vhl}/E_{vlh}						
Response time	"Low"→"High" propagation time	IS437	$T_a=25^\circ\text{C}$ $E_v=50\ell_x$ $R_L=280\Omega$	—	5	15	μs	
		IS438		t_{PLH}	—	3		9
	"High"→"Low" propagation time	IS437		t_{PHL}	—	3		9
		IS438		t_{PHL}	—	5		15
	Rise time	t_r		—	0.1	0.5		
	Fall time	t_f		—	0.05	0.5		

4

- *2 Defines $E_v=50\ell_x$ (IS437) and $E_v=0$ (IS438).
- *3 Defines $E_v=0$ (IS437) and $E_v=50\ell_x$ (IS438).
- *4 E_{vhl} represents illuminance by CIE standard light source A (tungsten lamp) when output changes from high to low.
- *5 E_{vlh} represents illuminance by CIE standard light source A (tungsten lamp) when output changes from low to high.
- *6 Hysteresis stands for E_{vlh}/E_{vhl} (IS437) and E_{vhl}/E_{vlh} (IS438).

Recommended Operating Conditions

Parameter	Symbol	MIN.	MAX.	Unit
Supply voltage	V_{cc}	4.5	20	V
Output voltage	V_o	0	30	V
Output current	I_o	—	16	mA

Fig. 1 Power Dissipation vs. Ambient Temperature

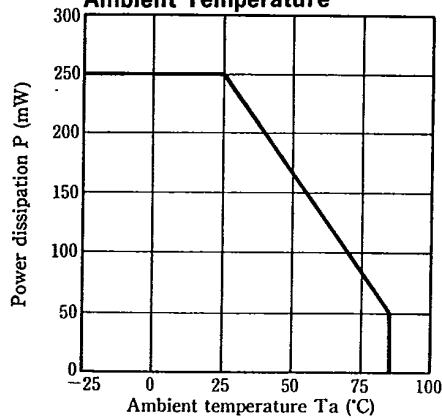
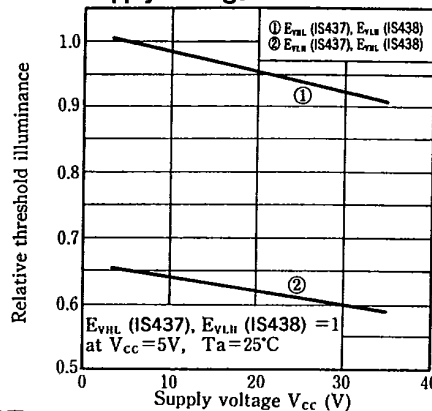

Fig. 2 Relative Threshold Illuminance vs. Supply Voltage



T-41-69

Fig. 3 Low Level Output Voltage vs. Low Level Output Current

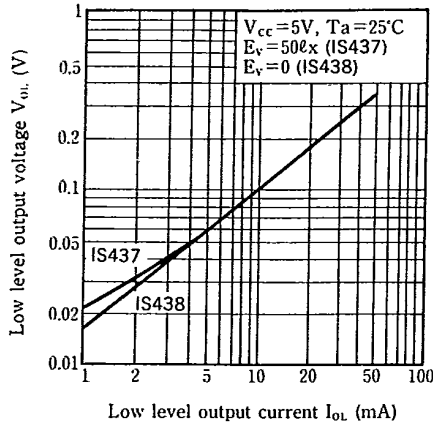

Fig. 4 Low Level Output Voltage vs. Ambient Temperature

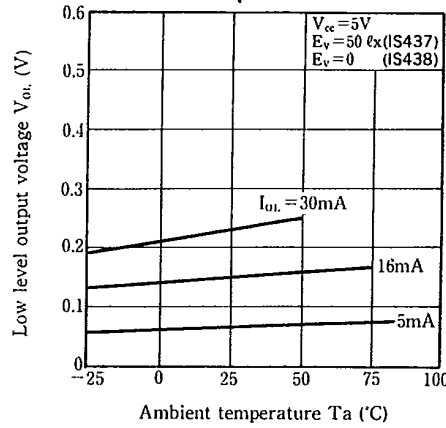

Fig. 5 Supply Current vs. Ambient Temperature

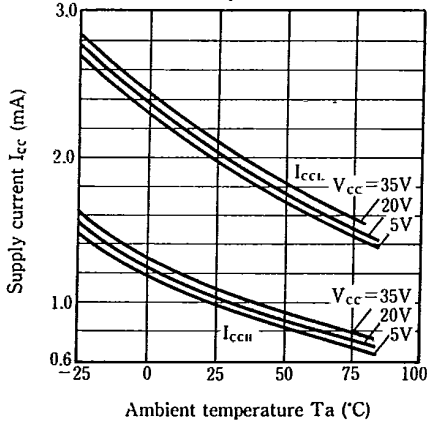

Fig. 6 Propagation Time vs. Illuminance

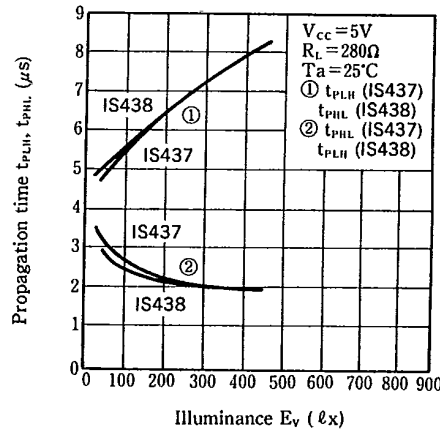
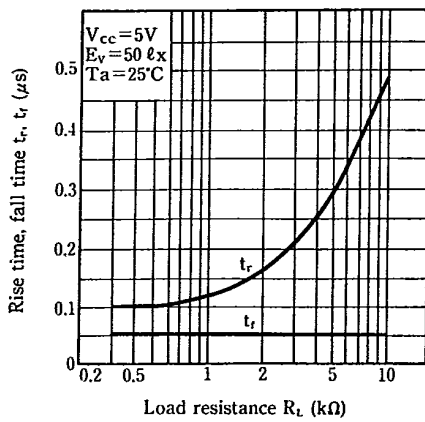
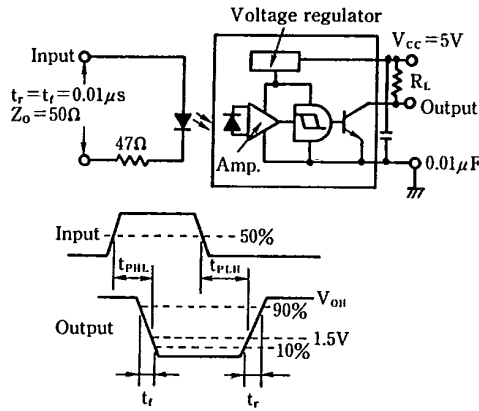

Fig. 7 Rise Time, Fall Time vs. Load Resistance



Test Circuit for Response Time (IS437)



T-41-69

Test Circuit for Reseponse Time (IS438)

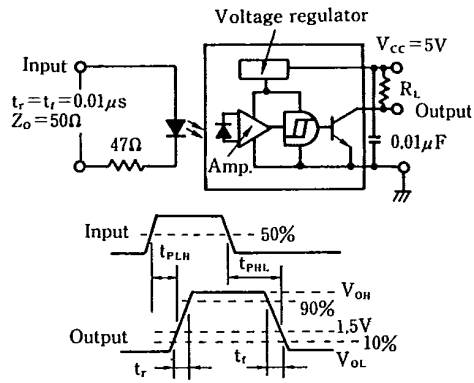

Fig. 8 Sensivity Diagram (Ta = 25°C)

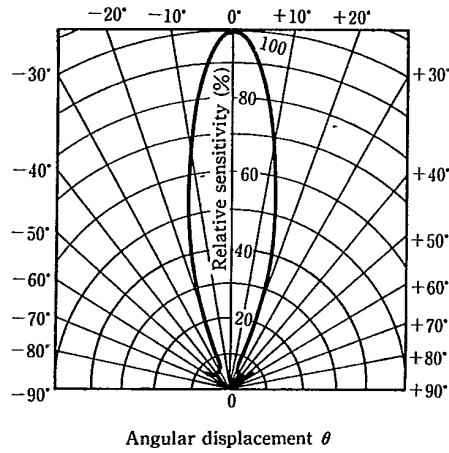
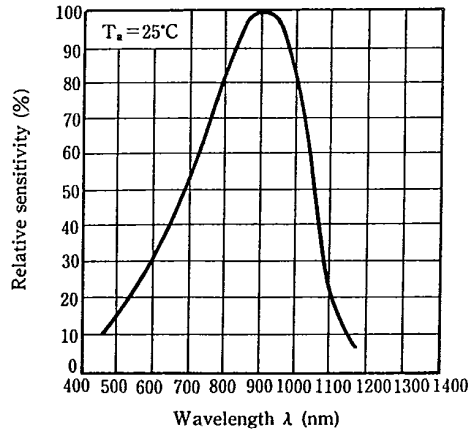

Fig. 9 Spectral Sensitivity



4