

#### 2 INPUT NOR GATE

#### FEATURES

- High output drive :  $\pm 24\text{mA}(\text{min.}) @ V_{CC}=3\text{V}$ .
- Super high speed operation :  $t_{pd} 2.4\text{ns}(\text{typ.}) @ V_{CC}=5\text{V}, 50\text{pF}$ .
- Operation voltage range :  $V_{CC(\text{opr})}=1.65\sim 5.5\text{V}$ .
- Power down protection is provided on all inputs and outputs.

#### MARKING

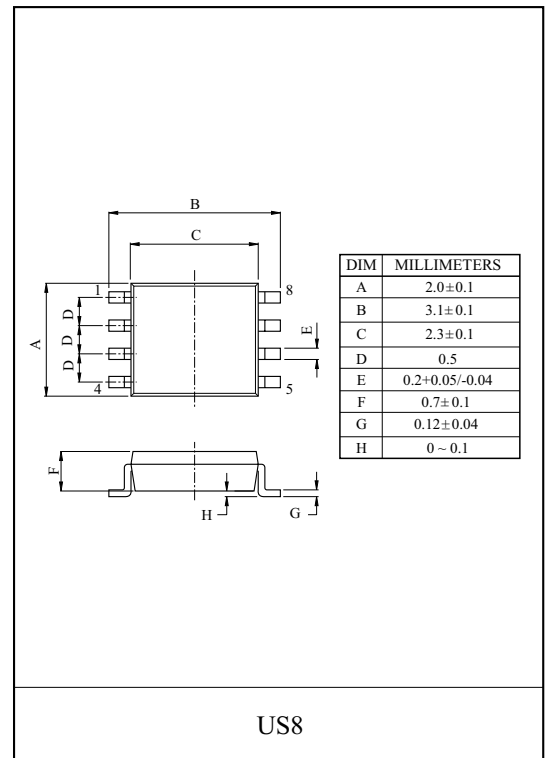
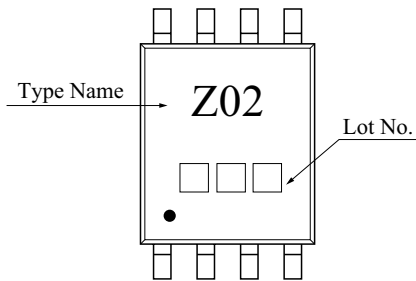

#### MAXIMUM RATINGS (Ta=25 °C)

CHARACTERISTIC	SYMBOL	RATING	UNIT
Power Supply Voltage	$V_{CC}$	-0.5~7	V
DC Input Voltage	$V_{IN}$	-0.5~7	V
DC Output Voltage	$V_{OUT}$	-0.5~7	V
Input Diode Current	$I_{IK}$	-50	mA
Output Diode Current	$I_{OK}$	-50	mA
DC Output Current	$I_{OUT}$	±50	mA
DC $V_{CC}$ /ground Current	$I_{CC}$	±100	mA
Power Dissipation	$P_D$	200	mW
Storage Temperature Range	$T_{stg}$	-55 ~ 150	°C
Lead Temperature (10s)	$T_L$	-55 ~ 150	°C

#### PIN CONNECTION(TOP VIEW)

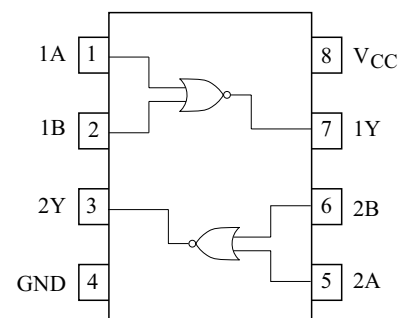

# KIC7WZ02FK

Truth Table

A	B	Y
L	L	H
L	H	L
H	L	L
H	H	L

Logic Diagram

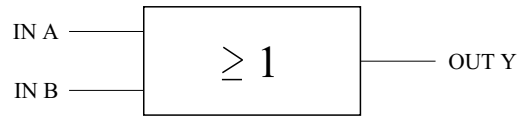

Recommended Operating Conditions

CHARACTERISTIC	SYMBOL	RATING	UNIT
Supply Voltage	$V_{CC}$	1.65~5.5	V
		1.5~5.5 (Note1)	
Input Voltage	$V_{IN}$	0~5.5	V
Output Voltage	$V_{OUT}$	0~5.5 (Note2)	V
		0~ $V_{CC}$ (Note3)	
Operating Temperature	$T_{opr}$	-40~85	°C
Input Rise and Fall Time	$d_r/d_f$	0~20 ( $V_{CC}=1.8V \pm 0.15V, 2.5V \pm 0.2V$ )	ns/V
		0~10 ( $V_{CC}=3.3V \pm 0.3V$ )	
		0~5 ( $V_{CC}=5.5V \pm 0.5V$ )	

Note1 : Data retention only.

Note2 :  $V_{CC}=0V$ .

Note3 : High or low state

# KIC7WZ02FK

## ELECTRICAL CHARACTERISTICS

### DC Characteristics

CHARACTERISTIC		SYMBOL	TEST CONDITION		Ta=25 °C			Ta=-40~85 °C		UNIT	
					V <sub>CC</sub> (V)	MIN.	TYP.	MAX.	MIN.		MAX.
Input Voltage	High Level	V <sub>IH</sub>	-	1.65~1.95	0.75 × V <sub>CC</sub>	-	-	0.75 × V <sub>CC</sub>	-	V	
				2.3~5.5	0.7 × V <sub>CC</sub>	-	-	0.7 × V <sub>CC</sub>	-		
	Low Level	V <sub>IL</sub>	-	1.65~1.95	-	-	0.25 × V <sub>CC</sub>	-	0.25 × V <sub>CC</sub>		
				2.3~5.5	-	-	0.3 × V <sub>CC</sub>	-	0.3 × V <sub>CC</sub>		
Output Voltage	High Level	V <sub>OH</sub>	V <sub>IN</sub> = V <sub>IL</sub>	I <sub>OH</sub> = -100 μA	1.65	1.55	1.65	-	1.55	-	V
					2.3	2.2	2.3	-	2.2	-	
					3.0	2.9	3.0	-	2.9	-	
					4.5	4.4	4.5	-	4.4	-	
				I <sub>OH</sub> = -4mA	1.65	1.29	1.52	-	1.29	-	
					2.3	1.9	2.15	-	1.9	-	
					3.0	2.4	2.8	-	2.4	-	
					4.5	3.8	4.2	-	3.8	-	
	Low Level	V <sub>OL</sub>	V <sub>IN</sub> = V <sub>IH</sub>	I <sub>OH</sub> = 100 μA	1.8	-	0	0.1	-	0.1	V
					2.3	-	0	0.1	-	0.1	
					3.0	-	0	0.1	-	0.1	
					4.5	-	0	0.1	-	0.1	
				I <sub>OH</sub> = 4mA	1.65	-	0.08	0.24	-	0.24	
					2.3	-	0.1	0.3	-	0.3	
					3.0	-	0.15	0.4	-	0.4	
					4.5	-	0.22	0.55	-	0.55	
I <sub>OH</sub> = 8mA	2.3	-	0.1	0.3	-	0.3					
	3.0	-	0.15	0.4	-	0.4					
I <sub>OH</sub> = 16mA	3.0	-	0.15	0.4	-	0.4					
	4.5	-	0.22	0.55	-	0.55					
I <sub>OH</sub> = 24mA	3.0	-	0.22	0.55	-	0.55					
	4.5	-	0.22	0.55	-	0.55					
Input Leakage Current		I <sub>IN</sub>	V <sub>IN</sub> =5.5V or GND	0~5.5	-	-	±0.1	-	±10	μA	
Power Off Leakage Current		I <sub>OFF</sub>	V <sub>IN</sub> or V <sub>OUT</sub> =5.5V	0.0	-	-	1	-	10	μA	
Quiescent Supply Current		I <sub>CC</sub>	V <sub>IN</sub> =5.5V or GND	1.65~5.5	-	-	1	-	10	μA	

### AC Characteristics (unless otherwise specified, Input : t<sub>r</sub>=t<sub>f</sub>=3ns)

CHARACTERISTIC		SYMBOL	TEST CONDITION		Ta=25 °C			Ta=-40~85 °C		UNIT
					V <sub>CC</sub> (V)	MIN.	TYP.	MAX.	MIN.	
Propagation delay time	t <sub>PLH</sub> t <sub>PHL</sub>	C <sub>L</sub> =15pF, R <sub>L</sub> =1M Ω	1.8 ± 0.15	2.0	5.4	9.8	2.0	10	ns	
			2.5 ± 0.2	1.2	3.3	5.4	1.2	5.8		
			3.3 ± 0.3	0.8	2.5	3.8	0.8	4.1		
			5.0 ± 0.5	0.5	2.0	3.0	0.5	3.3		
			C <sub>L</sub> =50pF, R <sub>L</sub> =500 Ω	3.3 ± 0.3	1.2	3.1	4.6	1.2	5.0	ns
				5.0 ± 0.5	0.8	2.4	3.7	0.8	4.0	
Input Capacitance		C <sub>IN</sub>	-	0	-	2.5	-	-	pF	
Power Dissipation Capacitance		C <sub>PD</sub>	(Note)	3.3	-	13.5	-	-	pF	
				5.5	-	17.5	-	-		

Note : C<sub>PD</sub> is defined as the value of the internal equivalent capacitance which is calculated from the operating current consumption without load. Average operating current can be obtained by the equation : I<sub>CC(oper)</sub> = C<sub>PD</sub> · V<sub>CC</sub> · f<sub>IN</sub> + (I<sub>CC</sub><sup>static</sup>)

# KIC7WZ02FK

## AC Loading and Waveforms

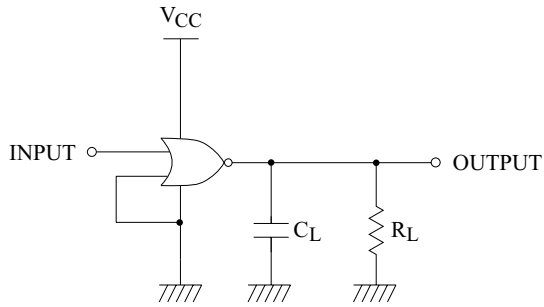

$C_L$  includes load and stray capacitance  
Input PRR=1.0MHz ;  $t_w$  =500ns

FIGURE 1. AC Test Circuit

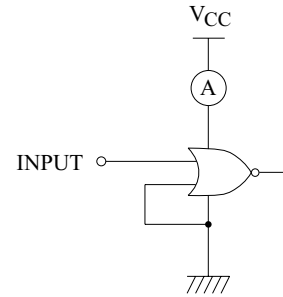

Input=AC Waveform ;  $t_r=t_f=1.8$ ns  
PRR=10MHz ; Duty Cycle=50%

FIGURE 2. ICCD Test Circuit

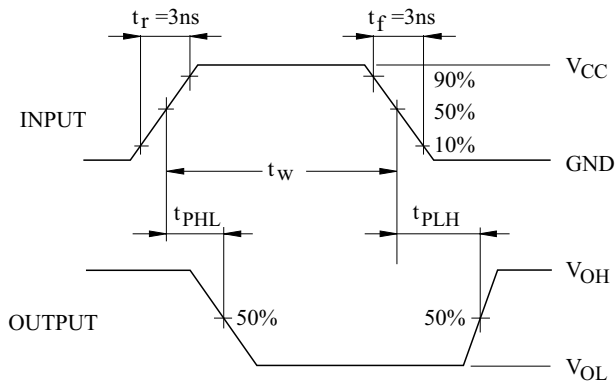

FIGURE 3. AC Waveforms