

# LN51F, LN51L

## GaAs Infrared Light Emitting Diodes

For optical control systems

### ■ Features

- High-power output, high-efficiency :  $P_O = 6 \text{ mW (typ.)}$
- Fast response :  $t_r, t_f = 1 \mu\text{s (typ.)}$
- Infrared light emission close to monochromatic light :  $\lambda_p = 950 \text{ nm (typ.)}$
- Narrow directivity, suitable for effective use of optical output :  $\theta = 8 \text{ deg. (LN51L)}$
- Wide directivity, matched for external optical systems :  $\theta = 32 \text{ deg. (LN51F)}$
- TO-18 standard type package

### ■ Absolute Maximum Ratings ( $T_a = 25^\circ\text{C}$ )

Parameter	Symbol	Ratings	Unit
Power dissipation	$P_D$	150	mW
Forward current (DC)	$I_F$	100	mA
Pulse forward current	$I_{FP}^*$	2	A
Reverse voltage (DC)	$V_R$	5	V
Operating ambient temperature	$T_{opr}$	-25 to +100	$^\circ\text{C}$
Storage temperature	$T_{stg}$	-30 to +100	$^\circ\text{C}$

\*  $f = 100 \text{ Hz}$ , Duty cycle = 0.1 %

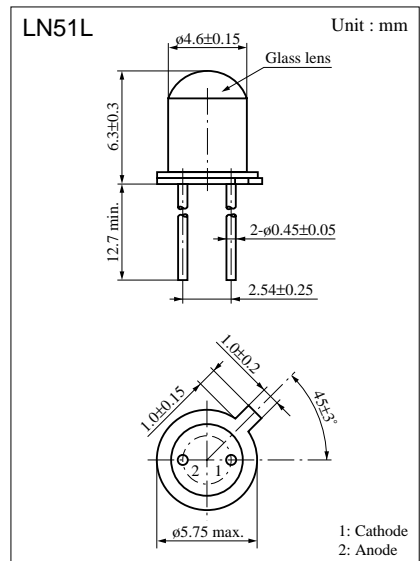
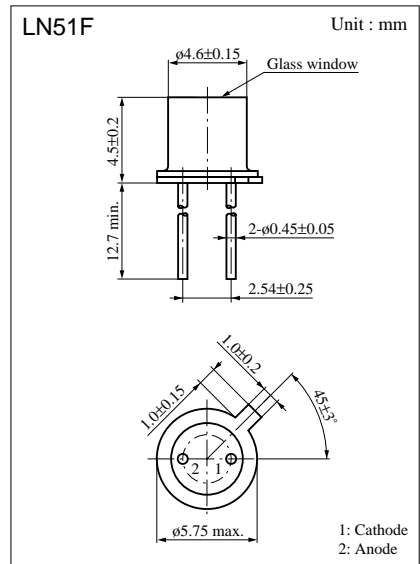

### ■ Electro-Optical Characteristics ( $T_a = 25^\circ\text{C}$ )

Parameter	Symbol	Conditions	min	typ	max	Unit
Radiant power	$P_O$	$I_F = 100\text{mA}$	3	6		mW
Peak emission wavelength	$\lambda_p$	$I_F = 100\text{mA}$		950		nm
Spectral half band width	$\Delta\lambda$	$I_F = 100\text{mA}$		50		nm
Forward voltage (DC)	$V_F$	$I_F = 100\text{mA}$		1.25	1.5	V
Reverse current (DC)	$I_R$	$V_R = 5\text{V}$		0.005	10	$\mu\text{A}$
Capacitance between pins	$C_t$	$V_R = 0\text{V}$ , $f = 1\text{MHz}$		50		pF
Rise time	$t_r$	$I_{FP} = 100\text{mA}$		1		$\mu\text{s}$
Fall time	$t_f$			1		$\mu\text{s}$
Half-power angle	LN51F	$\theta$	The angle in which radiant intensity is 50%		32	deg.
	LN51L				8	deg.

