

# Adjustable Flow Switches



## M-201-T Series

High flow,  
adjustable flow switch  
with right-angle flow

### Features

- Field adjustable – infinite flow range
- High repeatability
- Extremely sensitive
- Minimum pressure drop
- Position insensitive

### Applications

- Cleaning Tools in the semiconductor industry
- Cooling systems
- Water treatment systems
- Process flows

The M-201-T Series flow switches are engineered and field tested for sensing increasing and decreasing flow rates of gases or liquids. Pressure variation effects are minimal. This series features such versatility, economy, and accuracy that they can be used in virtually any application requiring fool-proof inexpensive flow detection.

### Operation

The flow switch is activated by flow forcing a piston kept in place by a spring to travel past a reed switch. This provides a positive signal after a certain amount of travel. Set point adjustment is controlled by adjusting the positioning of the reed switch.

### Custom Versions Available

Malema welcomes the opportunity to apply its flow sensor experience to work for its customers. Please contact the factory for any special requirements; such as ports, extreme temperature and pressure capabilities, etc.

### Calibration Range \*

<b>3/8" Flare</b>	Water:	0.03 - 3 gpm
	Air:	1 - 30 scfm
<b>1/2" Flare</b>	Water:	0.1 - 5 gpm
	Air:	1 - 50 scfm

\* Maximum flows through switch are higher.

For higher flow settings, contact factory.

### Specifications

Set Point Accuracy:	±10% maximum
Repeatability:	±2%
Hysteresis:	30%
(lower hysteresis on request)	

### Material Versions

- PTFE

### Port Sizes

- 3/8" Flare
- 1/2" Flare

## Design Considerations/Construction

The M-201-T Series comprises a Body, Piston, and PTFE coated Spring. The M-201-T Series contains two moving parts (i.e. the piston and spring) and a retaining ring that are in the fluid path. Construction of the piston is important from a design perspective. A PTFE Encapsulated piston is used in this switch to ensure that all wetted parts are PTFE or PTFE coated.

## Standard Specifications by Materials

Housing	PTFE
Piston	PTFE Encapsulated
Spring	PTFE Coated Stainless Steel
<b>Pressure and Temperature Specifications</b>	200 600 149 C (300°F)
Maximum Operating (psig)	
Burst (psig)	
Maximum Operating Temperature	
<b>Reed Switch Data (Electrical Ratings)</b>	
Reed Switch	10 Watts SPST or 3 Watts SPDT (Hermetically Sealed) UL Recognized. File E47258
Switching Voltage	200 VDC (170 VDC for SPDT)
Breakdown Voltage	250 VDC (200 VDC for SPDT)
DC Resistive	10 Watts (3 Watts for SPDT)
AC Resistive	10 VA (3VA for SPDT)
Switching Current	0.5 A (0.25 VA for SPDT)
Carrying Current	1.2 A (0.5A for SPDT)
Lead Wires	No. 24 to 18 AWG. 18" Length, Polymeric UL Recognized or Belden cable with connectors to suit
Lead Wires Color	SPST: 2 Blue wires; SPDT: Green - Common, Yellow - Normally Closed, Orange - Normally Open
Flow Calibration*	(Higher accuracy units available)
Set Point Accuracy	10% maximum
Set Point Differential	30% (lower hysteresis on request)
Repeatability	+ 2% maximum

\* For custom calibration requirements, contact factory

## Reed Switch Ratings as Recognized by UL

SPST	120 V ac 24 V dc 50 V dc	0.1 A general purpose 0.25 A resistive 0.25 A resistive
SPDT	120 V ac 10 V dc 24 V dc	0.1 A general purpose 0.25 A resistive 0.1 A resistive

# Adjustable Flow Switches

## Installation & Maintenance

This product can be mounted in any orientation. Adequate filtration and sealing procedures should be used when mounting in flow lines. For detailed directions, please refer to our "Installation and Maintenance" sheet.

## Certifications

- Meet the intent of Directive 89/336/EEC for Electromagnetic Compatibility and Low Voltage Directive 73/23/EEC for Product Safety. Compliance was demonstrated to the following specifications as listed in the Official Journal of the European Communities: EMC Directive 89/336/EEC: EN 55011, Class B Radiated Emissions, EN 50082-1 (Immunity); IEC 801-2, Electrostatic Discharge Immunity, IEC 801-3, RF Electromagnetic Field Immunity; Low Voltage Directive 73/23/EEC: EN 61010-1, Safety Requirements for electrical equipment for measurement, control, and laboratory use.

## Cv

3/8" Flare's: Cv = 3.0

1/2" Flare's: Cv = 3.5

## Dimensional and Cut-Away Drawings

*Illustrated is the M-201-T Model with 3/8" Flare's.*

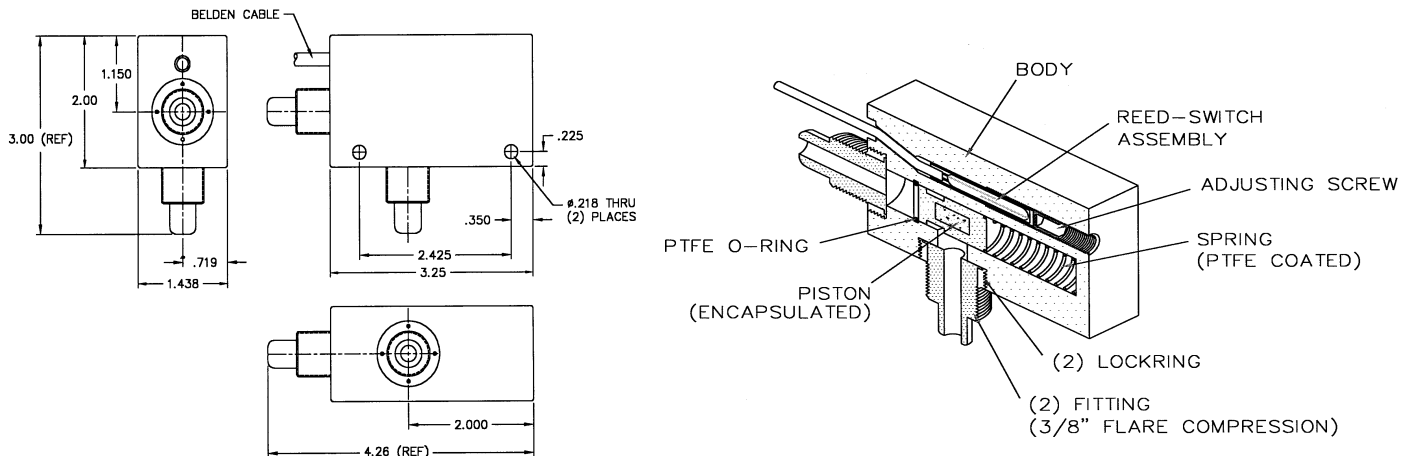

## Dimensional and Cut-Away Drawings (continued)

Illustrated below is the M-201-T Model with 1/2" flares.

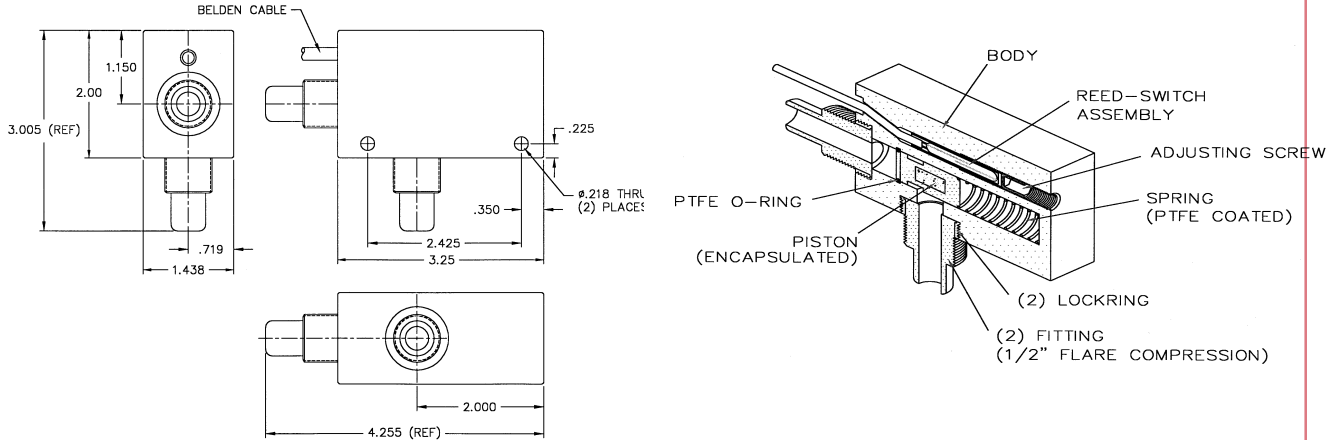

## Factory Preset Information

The M-201-T is an adjustable flow switch. The flow set point can be set at the factory, upon request. Proper calibration of the set point requires the following information. When purchasing a flow switch that needs to be factory preset, use the "Set Point Calibration" form on page i-vi or provide this information on the purchase order.

- Calibration set point,
- Increasing or decreasing flow,
- Fluid type (i.e. liquid or gas),
- Density or specific gravity,
- Viscosity,
- System pressure and temperature,
- Flow direction (i.e. upward or downward), and
- Mounting orientation (i.e. horizontal or vertical).

## Ordering Information

Standard Part Numbering							
M	-	Model	-	Material	Port	Switch	
M	-	201	-	T	3	1	- XXX
		201		T - PTFE	3 - 3/8" Flare's 4 - 1/2" Flare's	1 - SPST N.O. 3 - SPDT	3 digit number to identify unique requirement such as setting and cable assembly requirements to suit customers applications