



The Future of Analog IC Technology®

EV0060 (MP1567) 1.2A, 6V, 800KHz Synchronous Rectified Step-Down Converter

EVALUATION BOARD

GENERAL DESCRIPTION

The EV0060 is an evaluation board for the MP1567, a 1.2A, 800KHz DC to DC converter designed for low voltage applications requiring high efficiency. Capable of providing output voltages as low as 0.9V from a 3.3V supply voltage, the MP1567 eliminates the need for a 5V rail, providing over 90% efficiency via synchronous rectification and eliminating heat issues in confined spaces. Soft-start operation protects internal circuitry from hard turn on issues. Switching at 800KHz reduces the size of external components and thereby reduces board space.

The MP1567 includes cycle-by-cycle current limiting and under voltage lockout. Internal power switches combined with the tiny 10-pin QFN package provide a solution requiring a minimum of space.

ELECTRICAL SPECIFICATIONS

Parameter	Symbol	Value	Units
Input Voltage	V_{IN}	2.6 to 6	V
Output Voltage	V_{OUT}	1.8	V
Output Current	I_{OUT}	1.2	A

FEATURES

- 1.2A Output Current
- Synchronous Rectified
- Internal 180mΩ and 220mΩ Power Switches
- V_{IN} Range of 2.6V to 6V
- Over 90% Efficiency
- Zero Current Shutdown Mode
- Under Voltage Lockout Protection
- Soft-Start Operation
- Thermal Shutdown
- Internal Current Limit (Source & Sink)
- Tiny 10-Pin QFN Package

APPLICATIONS

- SOHO Routers, PCMCIA Cards, Mini PCI
- Handheld Computers, PDAs
- Cell Phones
- Digital Video Cameras
- Small LCD Displays

"MPS" and "The Future of Analog IC Technology", are Registered Trademarks of Monolithic Power Systems, Inc.

EV0060 EVALUATION BOARD

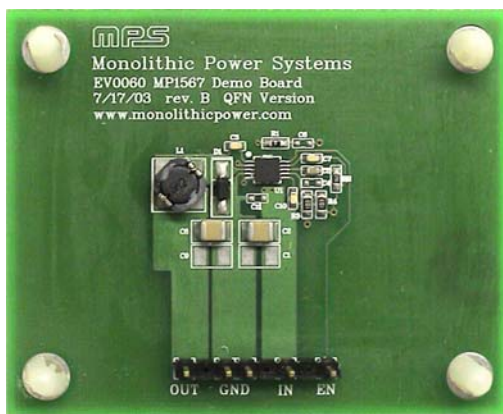

Dimensions (2.5"X x 2.0"Y x 0.4"Z)

Board Number	MPS IC Number
EV0060	MP1567DQ

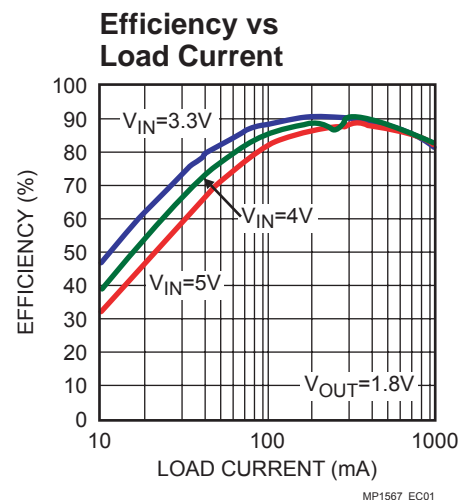

EVALUATION BOARD SCHEMATIC

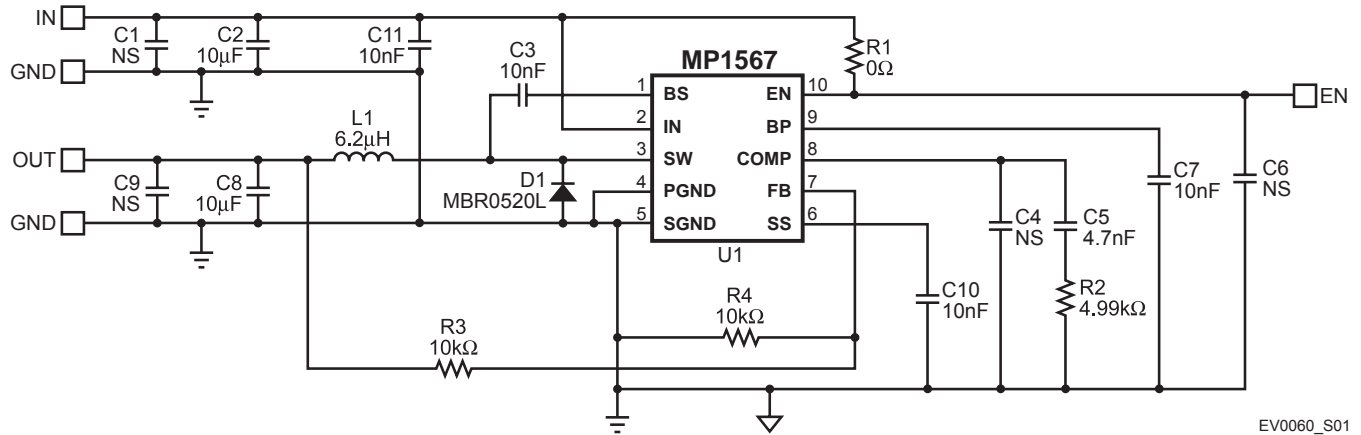

EV0060_S01

EV0060 BILL OF MATERIALS

Qty	Ref	Value	Description	Package	Manufacturer P/N	Distributor P/N
4	C1, C4, C6, C9	NS	Not Stuffed			
2	C2, C8	10µF	Capacitor			
4	C3, C7, C10, C11	10nF	Capacitor			
1	C5	4.7nF	Capacitor			
1	D1		Diode		MBR0520L	
1	L1	6.2µH	Inductor		Sumida CDRH5D18	
1	R1	0Ω				
1	R2	4.99kΩ	Resistor			
2	R3, R4	10kΩ	Resistor, 1%			
1	U1		Step-Down Converter	QFN10	MPS MP1567DK	

PRINTED CIRCUIT BOARD LAYOUT

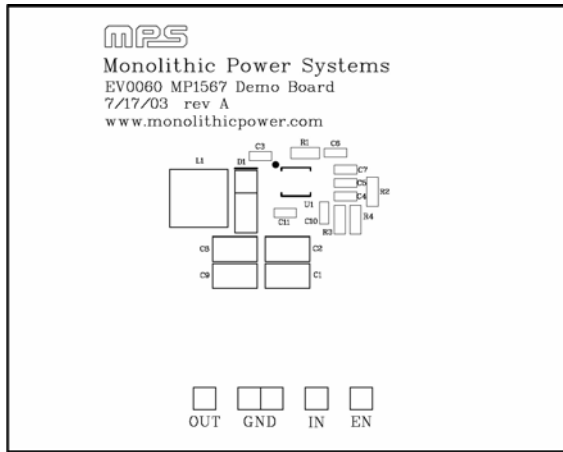

Figure 1—Top Silk Layer

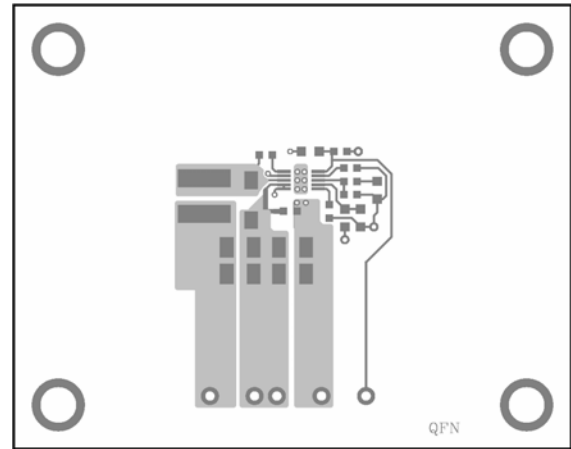

Figure 2—Top Layer

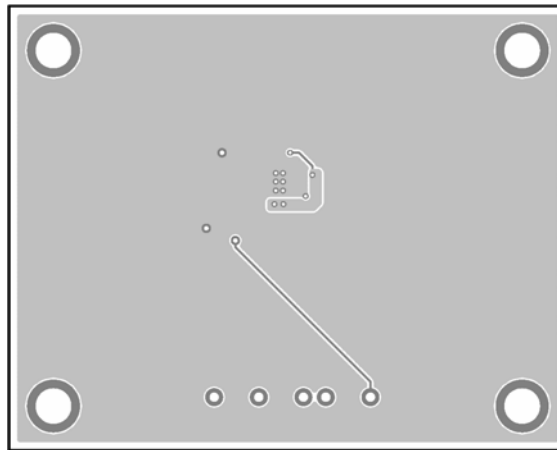
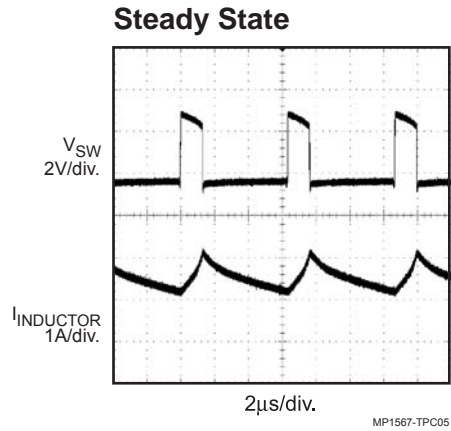
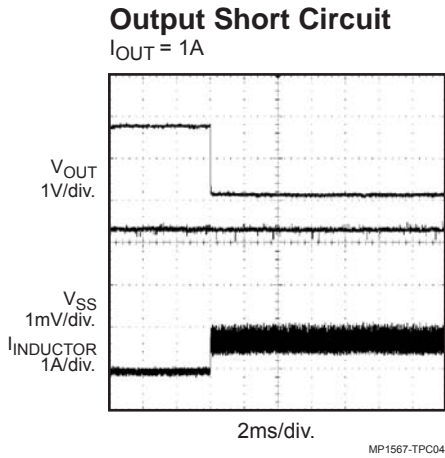
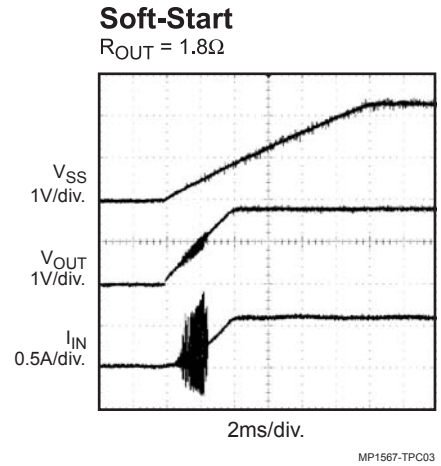
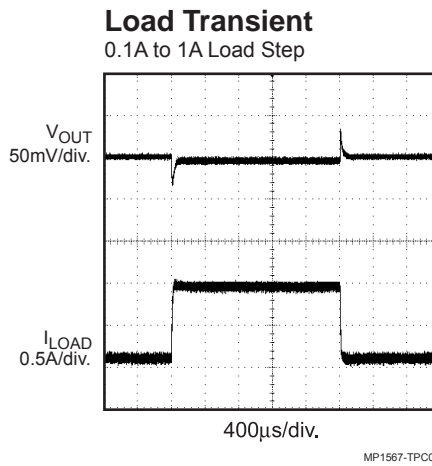
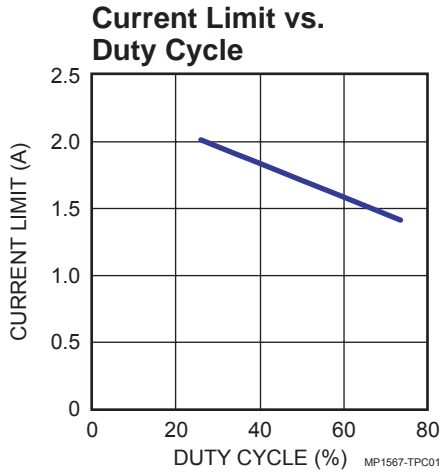

Figure 3—Bottom Layer

TYPICAL PERFORMANCE CHARACTERISTICS

$V_{IN} = 3.3V$, $V_{OUT} = 1.8V$, $T_A = +25^{\circ}C$, unless otherwise noted.



QUICK START GUIDE

The output voltage of this board is set to 1.8V. The board layout accommodates most commonly used inductors and output capacitors.

1. Attach the positive and negative ends of the load to the OUT and GND pins respectively.
2. Attach an input voltage $2.6V \leq V_{IN} \leq 6V$ and the input ground to the IN and GND pins, respectively.
3. To enable the MP1567 apply a voltage, $2V \leq V_{EN} \leq 6V$, to the EN pin. To disable the MP1567 connect the EN pin to ground.
4. The output voltage V_{OUT} can be changed by varying R3. Calculate the new value using the formula:

$$R3 = R4 \times \left(\frac{V_{OUT}}{V_{FB}} - 1 \right)$$

Where $V_{FB} = 0.9V$ and $R4 = 10k\Omega$.

For example, for $V_{OUT} = 2.5V$:

$$R3 = R4 \times \left(\frac{V_{OUT}}{V_{FB}} - 1 \right) = 10k\Omega \times \left(\frac{2.5V}{0.9V} - 1 \right) = 17.78k\Omega$$

Therefore use a standard 1% value 17.8k Ω resistor.

Note: See Maximum Duty Cycle limits to determine allowable output voltages.

NOTICE: The information in this document is subject to change without notice. Please contact MPS for current specifications. Users should warrant and guarantee that third party Intellectual Property rights are not infringed upon when integrating MPS products into any application. MPS will not assume any legal responsibility for any said applications.