

FEATURES

- CYLINDRICAL V-CHIP CONSTRUCTION FOR SURFACE MOUNTING
- VERY LOW IMPEDANCE & HIGH RIPPLE CURRENT AT 100K Hz
- SUITABLE FOR DC-DC CONVERTER, DC-AC INVERTER, ETC.
- NEW EXPANDED CV RANGE, UP TO 6800μF
- **NEW HIGH TEMPERATURE REFLOW "M1" VERSION**
- DESIGNED FOR AUTOMATIC MOUNTING AND REFLOW SOLDERING

RoHS Compliant
includes all homogeneous materials

*See Part Number System for Details



CHARACTERISTICS

Rated Voltage Rating	6.3 ~ 50Vdc							
Rated Capacitance Range	4.7 ~ 6800μF							
Operating Temp. Range	-55 ~ +105°C							
Capacitance Tolerance	±20% (M), ±10%(K)*							
Max. Leakage Current After 2 Minutes @ 20°C	0.01CV Or 3μA, whichever is greater							
Tan δ @ 120Hz/20°C	W.V. (Vdc)		6.3	10	16	25	35	50
	S.V. (Vdc)		8.0	13	20	32	44	63
	φ4 ~ φ6.3mm Dia.		0.24	0.20	0.16	0.14	0.12	0.10
	φ8 ~ φ16mm Dia.	C ≤ 1000μF	0.28	0.24	0.20	0.16	0.14	0.14
		C = 1500μF	0.29	0.25	0.21	-	0.14	-
		C = 2200μF	0.30	0.26	-	0.18	-	-
		C = 3300μF	0.32	-	0.24	-	-	-
C = 4700μF		0.34	0.30	-	-	-	-	
C = 6800μF	0.38	-	-	-	-	-		
Low Temperature Stability Impedance Ratio @ 120Hz	W.V. (Vdc)		6.3	10	16	25	35	50
	Z-40°C/Z+20°C		3	2	2	2	2	2
	Z-55°C/Z+20°C		5	4	4	3	3	3
Load Life Test @ 105°C 4 ~ 6mm Dia. 1,000 hours 8 ~ 12.5mm Dia. 2,000 hours	Capacitance Change		Within ±25% of initial measured value					
	Tan δ		Less than ±200% of the specified maximum value					
	Leakage Current		Less than the specified maximum value					

LOW IMPEDANCE AT HIGH FREQUENCY
INDUSTRY STANDARD
STYLE FOR SWITCHERS AND CONVERTERS

LOW ESR COMPONENT LIQUID ELECTROLYTE
For Performance Data see www.LowESR.com

* Optional ± 10% (K) Tolerance available on most values. Contact factory for availability.

MAXIMUM PERMISSIBLE RIPPLE CURRENT (mA rms AT 100KHz AND 105°C)

Cap (μF)	Working Voltage (Vdc)					
	6.3	10	16	25	35	50
4.7	-	-	-	-	80	60
10	-	-	-	80	150	165
15	-	-	80	150	150	-
22	-	80	150	150	150	165
27	80	-	-	-	-	-
33	-	150	-	230	230	195
47	150	-	230	230	230	195
56	150	-	-	230	-	-
68	-	230	230	230	280	300
100	230	-	230	280	450	300
120	-	230	-	-	-	-
150	230	230	280	450	450	450
220	230	280	280	450	450	450
330	280	450	450	450	670	620
390	-	-	-	-	-	620
470	450	450	450	670	900	790
680	450	-	670	-	900	-
1000	450	670	-	900	-	790
1500	670	-	900	-	1250	-
2200	-	900	-	1250	-	-
3300	900	-	1250	-	-	-
4700	-	1250	-	-	-	-
6800	1250	-	-	-	-	-

MAXIMUM IMPEDANCE (Ω AT 100KHz AND 20°C)

Cap (μF)	Working Voltage (Vdc)					
	6.3	10	16	25	35	50
4.7	-	-	-	-	1.80	2.90
10	-	-	-	1.80	0.76	0.88
15	-	-	1.80	0.76	0.76	-
22	-	1.80	0.76	0.76	0.76	0.88
27	1.80	-	-	-	-	-
33	-	0.76	-	0.44	0.44	0.75
47	0.76	-	0.44	0.44	0.44	0.75
56	0.76	-	-	0.44	-	-
68	-	0.44	0.44	0.44	0.34	0.40
100	0.44	-	0.44	0.34	0.17	0.40
120	-	0.44	-	-	-	-
150	0.44	0.44	0.34	0.17	0.17	0.22
220	0.44	0.34	0.34	0.17	0.17	0.22
330	0.34	0.17	0.17	0.17	0.09	0.14
390	-	-	-	-	-	0.14
470	0.17	0.17	0.17	0.09	0.066	0.078
680	0.17	-	0.09	-	0.066	-
1000	0.17	0.09	-	0.066	-	0.078
1500	0.09	-	0.066	-	0.052	-
2200	-	0.066	-	0.052	-	-
3300	0.066	-	0.052	-	-	-
4700	-	0.052	-	-	-	-
6800	0.052	-	-	-	-	-

PRECAUTIONS

Please review the notes on correct use, safety and precautions found on pages T10 & T11 of NIC's Electrolytic Capacitor catalog.
Also found at www.niccomp.com/precautions
If in doubt or uncertainty, please review your specific application - process details with NIC's technical support personnel: tpmg@niccomp.com



STANDARD PRODUCT AND CASE SIZE TABLE D ϕ x L (mm)

Cap (μ F)	Code	Working Voltage (Vdc)					
		6.3	10	16	25	35	50
4.7	4R7	-	-	-	-	4x6.3	4x6.3
10	100	-	-	-	4x6.3*	5x6.3*	6.3x6.3*
15	150	-	-	4x6.3	6x6.3	5x6.3*	-
22	220	-	4x6.3	5x6.3*	5x6.3	5x6.3*	6.3x6.3*
27	270	4x6.3*	-	-	-	-	-
33	330	-	5x6.3	-	6.3x6.3	6.3x6.3*	6.3x8*
47	470	5x6.3	-	6.3x6.3	6.3x6.3	6.3x6.3*	6.3x8*
56	560	5x6.3*	-	-	6.3x6.3	-	-
68	680	-	6.3x6.3	6.3x6.3*	6.3x6.3	6.3x8*	8x10.5*
100	101	6.3x6.3*	-	6.3x6.3*	6.3x8*	8x10.5	8x10.5*
120	121	-	6.3x6.3	-	-	-	-
150	151	6.3x6.3	6.3x6.3	6.3x8*	8x10.5*	8x10.5* 10x8	10x10.5*
220	221	6.3x6.3	6.3x8	6.3x8*	8x10.5* 10x8	8x10.5	10x10.5
330	331	6.3x8*	8x10.5	8x10.5* 10x8	8x10.5	10x10.5	12.5x14
390	391	-	-	-	-	-	12.5x14
470	471	8x10.5	8x10.5 10x8	8x10.5	10x10.5*	12.5x14	16x17
680	681	8x10.5 10x8*	-	10x10.5	-	12.5x14	-
1000	102	8x10.5*	10x10.5	-	12.5x14	-	16x17
1500	152	10x10.5*	-	12.5x14	-	16x17	-
2200	222	-	12.5x14	-	16x17	-	-
3300	332	12.5x14	-	16x17	-	-	-
4700	472	-	16x17	-	-	-	-
6800	682	16x17	-	-	-	-	-

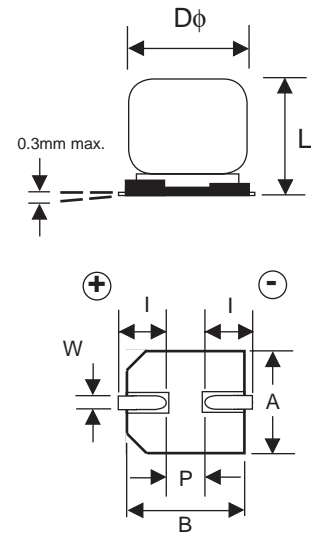

*Values available in optional 10% tolerance

Denotes New Value

DIMENSIONS (mm)

Case Size	ϕ D \pm 0.5	L max.	A \pm 0.2	B \pm 0.2	I \pm 0.3	W	P \pm 0.3
4x6.3	4.0	6.3	4.3	4.3	1.8	0.5~0.8	1.0
5x6.3	5.0	6.3	5.3	5.3	2.2	0.5~0.8	1.4
6.3x6.3	6.3	6.3	6.6	6.6	2.5	0.5~0.8	2.2
6.3x8	6.3	8.0	6.6	6.6	2.5	0.5~0.8	2.2
8x10.5	8.0	10.5	8.3	8.3	2.9	0.7~1.0	3.2
10x8	10.0	8.0	10.3	10.3	3.2	1.1~1.4	4.6
10x10.5	10.0	10.5	10.3	10.3	3.2	1.1~1.4	4.6
12.5x14	12.5	14.0	12.8	12.8	4.5	1.1~1.4	4.6
16x17	16.0	17.0	16.3	16.3	5.0	1.8~2.1	7.0

PEAK REFLOW SOLDERING TEMPERATURES AND DURATIONS (STANDARD VERSION)

Case Size	Preheat: 150°C ~ 180°C	Max. Soldering Temperature	Max. Exposure Time at Max. Soldering Temperature	Max. Exposure Time Above +200°C	Multiple Reflow Exposure
4x6.3	120 seconds max.	+250°C	5 seconds	70 seconds	2 times max.
5x6.3	120 seconds max.	+250°C	5 seconds	70 seconds	2 times max.
6.3x6.3	120 seconds max.	+250°C	5 seconds	70 seconds	2 times max.
6.3x8	120 seconds max.	+250°C	5 seconds	70 seconds	2 times max.
8x10.5	120 seconds max.	+245°C	5 seconds	60 seconds	2 times max.
10x8	120 seconds max.	+240°C	5 seconds	50 seconds	2 times max.
10x10.5	120 seconds max.	+240°C	5 seconds	50 seconds	2 times max.
12.5x14	120 seconds max.	+240°C	5 seconds	50 seconds	2 times max.
16x17	120 seconds max.	+230°C	5 seconds	30 seconds	2 times max.

PEAK REFLOW SOLDERING TEMPERATURES AND DURATIONS (M1 VERSION)

Case Size	Preheat: 150°C ~ 180°C	Max. Soldering Temperature	Max. Exposure Time at Max. Soldering Temperature	Max. Exposure Time Above +200°C	Max. Exposure Time Above +230°C	Multiple Reflow Exposure
4x6.3	120 seconds max.	+255°C	5 seconds	60 seconds	30 seconds	2 times max.
5x6.3	120 seconds max.	+255°C	5 seconds	60 seconds	30 seconds	2 times max.
6.3x6.3	120 seconds max.	+255°C	5 seconds	60 seconds	30 seconds	2 times max.
6.3x8	120 seconds max.	+255°C	5 seconds	60 seconds	30 seconds	2 times max.
8x10.5	120 seconds max.	+255°C	5 seconds	60 seconds	30 seconds	2 times max.
10x8	120 seconds max.	+250°C	5 seconds	60 seconds	30 seconds	2 times max.
10x10.5	120 seconds max.	+250°C	5 seconds	60 seconds	30 seconds	2 times max.

RECOMMENDED REFLOW SOLDERING PROFILE

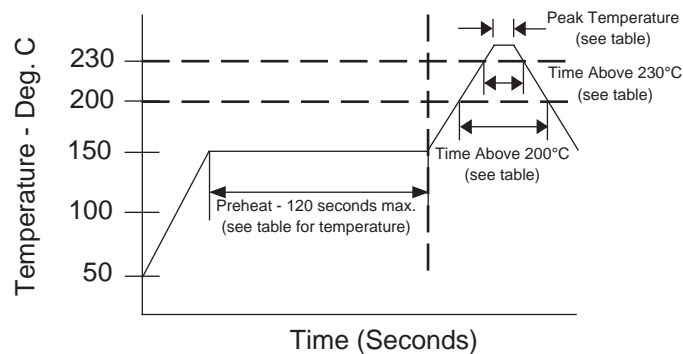

PART NUMBER SYSTEM

