

RoHS Compliant & Pb-Free Product

Typical Applications

- 3V Dual/Triple/Quad-Band Mode Handsets
- Commercial and Consumer Systems
- Portable Battery-Powered Equipment
- EDGE and GPRS Class 12 Compatible
- GSM850 and GSM900 Products
- DCS/PCS Products

Product Description

The RF3145 is a high power, high efficiency power amplifier module with integrated power control. This module is self-contained with 50Ω input and output terminals. The device is manufactured on an advance Gallium Arsenide Heterojunction Bipolar Transistor (HBT) process, and has been designed for use as the final dual-mode GMSK/8PSK RF amplifier in GSM, DCS and PCS handheld cellular equipment and other applications in the 824MHz to 849MHz, 880MHz to 915MHz, and in the 1710MHz to 1910MHz bands. Internal band select provides control to select the GSM850/GSM900 or DCS/PCS band. The device is packaged on ultra-small LCC, minimizing the required board space.

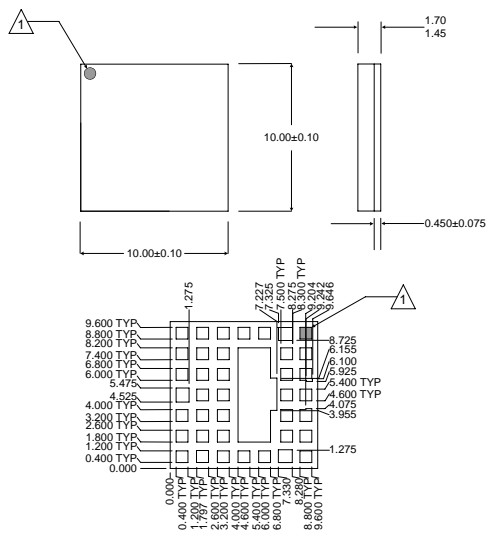

Optimum Technology Matching® Applied

- | | | |
|-------------------------------------|--|---|
| <input type="checkbox"/> Si BJT | <input checked="" type="checkbox"/> GaAs HBT | <input type="checkbox"/> GaAs MESFET |
| <input type="checkbox"/> Si Bi-CMOS | <input type="checkbox"/> SiGe HBT | <input checked="" type="checkbox"/> Si CMOS |
| <input type="checkbox"/> InGaP/HBT | <input type="checkbox"/> GaN HEMT | <input type="checkbox"/> SiGe Bi-CMOS |

Package Style: Module (10mmx10mm)

Features

- Integrated Power Control & Band Select
- Single 3.0V to 4.8V Supply Voltage
- +35.0dBm GSM Output Pwr at 3.5V
- +33dBm DCS/PCS Output Pwr at 3.5V
- +29dBm 8PSK Output Pwr
- 53% GSM and 50% DCS/PCS PAE

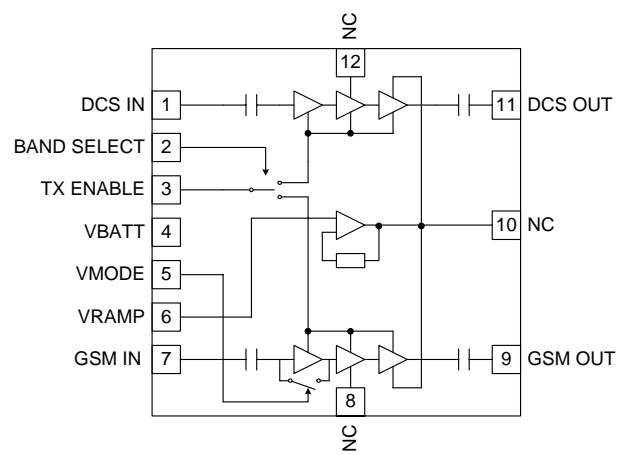

Functional Block Diagram

Ordering Information

RF3145 Quad-Band GSM/EDGE/GSM850/DCS/PCS Power Amplifier Module
Power Amplifier Module, 5 Piece Sample Pack
RF3145PCBA-41X Fully Assembled Evaluation Board

RF Micro Devices, Inc. Tel (336) 664 1233
7628 Thorndike Road Fax (336) 664 0454
Greensboro, NC 27409, USA http://www.rfmd.com

RF3145

Absolute Maximum Ratings

Parameter	Rating	Unit
Supply Voltage	-0.3 to +6.0	V
Power Control Voltage (V_{RAMP})	-0.3 to +1.8	V
Band Select	3.0	V
TX Enable	3.0	V
RF - Input Power	12.0	dBm
Max Duty Cycle	50	%
Output Load VSWR	10:1	
Operating Case Temperature	-30 to +90	°C
Storage Temperature	-55 to +150	°C



Caution! ESD sensitive device.

RF Micro Devices believes the furnished information is correct and accurate at the time of this printing. RoHS marking based on EU Directive 2002/95/EC (at time of this printing). However, RF Micro Devices reserves the right to make changes to its products without notice. RF Micro Devices does not assume responsibility for the use of the described product(s).

Parameter	Specification			Unit	Condition
	Min.	Typ.	Max.		
GSM US 850MHz Band					Temp = +25 °C, V_{CC} = 3.5V, Band Sel = Low, V_{MODE} = Low, V_{RAMP} = $V_{RAMP,MAX}$, P_{IN} = +4 dBm Freq = 824 MHz to 849 MHz, 25% Duty Cycle, Pulse Width = 1154 μ s, TX EN = High
Operating Frequency Range	824		849	MHz	
Maximum Output Power	+34.5	+35.4		dBm	Temp = 25 °C, V_{CC} = 3.5V, V_{RAMP} = $V_{RAMP,MAX}$
		+32.5		dBm	Temp = +85 °C, V_{BATT} = 3.0V, V_{RAMP} = $V_{RAMP,MAX}$
			0	dBm	V_{RAMP} = 0.2V
Total Efficiency (PAE)	45	51		%	At $P_{OUT,MAX}$, V_{CC} = 3.5V
		35		%	At P_{OUT} = 31.5 dBm
Input Power for Max Output	+2	+4	+6	dBm	
Folding Conversion Gain		-5		dB	F_0 = 849 MHz, other signal 829 MHz at -40 dBm, measured at 869 MHz in 100 kHz RBW (Max Power)
Output Noise Power		-86	-84	dBm	RBW = 100 kHz, 869 MHz to 894 MHz, $P_{OUT} \geq +5$ dBm
Forward Isolation			-25	dBm	TX_ENABLE = 0V, V_{RAMP} = 0.2, P_{IN} = +6 dBm
Second Harmonic			-5	dBm	Over all power levels
Third Harmonic		-30	-7	dBm	Over all power levels
All other Non-Harmonic Spurious			-36	dBm	
Cross Band Coupling $2F_0$			-20	dBm	Measured at DCS/PCS port. Over all power levels.
Input Impedance		50		Ω	
Input VSWR			2.5:1		Over all power levels
Output Load VSWR		6:1			Spurious < -36 dBm, V_{RAMP} = 0.2V to 1.6V, RBW = 3 MHz
Output Load Ruggedness		10:1			
Output Load Impedance		50		Ω	Load impedance presented at RF OUT pad

Note: $V_{RAMP,MAX} = 3/8 * V_{BATT} + 0.18 \leq 1.6V$

Parameter	Specification			Unit	Condition
	Min.	Typ.	Max.		
Power Control V_{RAMP}, GSM850 GMSK Mode					
Power Control "ON"			1.6	V	Max P_{OUT} , Voltage supplied to the input
Power Control "OFF"		0.2	0.25	V	Minimum P_{OUT} , Voltage supplied to the input.
Power Control Range		33		dB	$V_{RAMP}=0.2V$ to 1.6V
V_{RAMP} Input Capacitance		15		pF	DC to 2MHz
V_{RAMP} Input Current			10	μA	$V_{RAMP}=1.6V$
Turn On/Off Time			4	μS	$V_{RAMP}=0V$ to 1.6V
GSM US 850MHz Band 8PSK Mode					Temp= $+25^{\circ}C$, $V_{CC}=3.5V$, BandSelect=Low, $V_{MODE}=High$, $V_{RAMP}=V_{RAMP,MAX}$, Freq=824MHz to 849MHz, 25% Duty Cycle, Pulse Width=1154 μs
Operating Frequency Range	824		849	MHz	
Output Power to Meet EVM and ACPR Spectrum	+28.5	+29.0		dBm	
	+26.5			dBm	Temp= $-20^{\circ}C$ to $+85^{\circ}C$, $V_{CC}=3.2V$ At $P_{OUT,MAX}$, $V_{CC}=3.5V$
Total Efficiency (PAE)		25		%	
Gain	28.0	30.0	31.5	dB	
		28.5		dB	Temp= $-20^{\circ}C$ to $+85^{\circ}C$
Gain Temperature Coefficient		-0.03		db/ $^{\circ}$	Temp= $-20^{\circ}C$ to $+85^{\circ}C$, $V_{CC}=3.2V$ to 4.8V
EVM RMS		2.0	3.5	%	$P_{OUT}\leq 28.5$ dBm
			5.0	%	$P_{OUT}\leq 26.5$ dBm, $V_{CC}=3.2V$ to 4.8V, $\leq 2.5:1$ VSWR, All angles
ACPR and Spectrum Mask		-36	-34	dBc	At 200kHz in 30kHz BW, $P_{OUT}\leq 28.5$ dBm
		-60	-56	dBc	At 400kHz in 30kHz BW, $P_{OUT}\leq 28.5$ dBm
			-63	dBc	At 600kHz to 1800kHz in 30kHz BW, $P_{OUT}\leq 28.5$ dBm
Output Noise Power		-85	-84	dBm	RBW=100kHz, 869MHz to 894MHz, $P_{OUT}\geq +5$ dBm
Forward Isolation		-40	-30	dBm	TX Enable=0V, $V_{RAMP}=0.2V$, $P_{IN}=+6$ dBm
Second Harmonic			-7	dBm	Over all power levels
Third Harmonic			-7	dBm	Over all power levels
All other Non-Harmonic Spurious			-36	dBm	
Input Impedance		50		Ω	
Input VSWR			2.5:1		Over all power levels
Output Load VSWR		6:1			Spurious < -36dBm, $V_{RAMP}=0.2V$ to 1.6V, RBW=3MHz
Output Load Ruggedness		10:1			
Output Load Impedance		50		Ω	Load impedance presented at RF OUT pad

RF3145

Parameter	Specification			Unit	Condition
	Min.	Typ.	Max.		
GSM US 900MHz Band					Temp=+25 °C, V _{CC} =3.5V, BandSelect=Low, V _{MODE} =Low, V _{RAMP} =V _{RAMP,MAX} , P _{IN} =+4 dBm Freq=880MHz to 915MHz, 25% Duty Cycle, Pulse Width=1154 μs, TX EN=High
Operating Frequency Range	880		915	MHz	
Maximum Output Power	+34.5	+35.0		dBm	Temp = 25 °C, V _{CC} =3.5V, V _{RAMP} =V _{RAMP,MAX}
		+32.5		dBm	Temp=+85°C, V _{BATT} =3.0V, V _{RAMP} =V _{RAMP,MAX}
Total Efficiency (PAE)	45	55	0	dBm	V _{RAMP} =0.2V
		35		%	At P _{OUT,MAX} , V _{CC} =3.5V
Input Power for Max Output	+2	+4	+6	dBm	At P _{OUT} =31.5dBm
Folding Conversion Gain			-5	dB	F ₀ =915MHz, other signal 895MHz at -40dBm, measured at 935MHz in 100kHz RBW (Max Power)
Output Noise Power		-82	-80	dBm	RBW=100kHz, 925MHz to 935MHz, P _{OUT} ≥+5dBm
		-86	-84	dBm	RBW=100kHz, 935MHz to 960MHz, P _{OUT} ≥+5dBm
Forward Isolation			-25	dBm	TX_ENABLE=0V, V _{RAMP} =0.2, P _{IN} =+6dBm
Second Harmonic			-5	dBm	Over all power levels
Third Harmonic			-7	dBm	Over all power levels
All other Non-Harmonic Spurious			-36	dBm	
Cross Band Coupling 2F ₀			-20	dBm	Measured at DCS/PCS port. Over all power levels.
Input Impedance		50		Ω	
Input VSWR			2.5:1		Over all power levels
Output Load VSWR		6:1			Spurious<-36dBm, V _{RAMP} =0.2V to 1.6V, RBW=3MHz
Output Load Ruggedness		10:1			
Output Load Impedance		50		Ω	Load impedance presented at RF OUT pad

Note: $V_{RAMP,MAX} = 3/8 * V_{BATT} + 0.18 \leq 1.6V$

Power Control V_{RAMP}					
GSM900 GMSK Mode					
Power Control "ON"			1.6	V	Max P _{OUT} , Voltage supplied to the input
Power Control "OFF"		0.2	0.25	V	Minimum P _{OUT} , Voltage supplied to the input.
Power Control Range		33		dB	V _{RAMP} =0.2V to 1.6V
V _{RAMP} Input Capacitance		15		pF	DC to 2MHz
V _{RAMP} Input Current			10	μA	V _{RAMP} =1.6V
Turn On/Off Time			4	μS	V _{RAMP} =0V to 1.6V

Parameter	Specification			Unit	Condition
	Min.	Typ.	Max.		
GSM 900MHz Band 8PSK Mode					
Operating Frequency Range	880		915	MHz	Temp=+25 °C, V _{CC} =3.5V, BandSelect=Low, V _{MODE} =High, V _{RAMP} =V _{RAMP,MAX} , P _{IN} =+4dBm Freq=880MHz to 915MHz, 25% Duty Cycle, Pulse Width=1154μs
Output Power to Meet EVM and ACPR Spectrum	+28.5	+29.0		dBm	
Total Efficiency (PAE)	+26.5	25		%	Temp=-20°C to +85°C, V _{CC} =3.2V At P _{OUT,MAX} , V _{CC} =3.5V
Gain	28.0	29.5	31.0	dB	Temp=-20°C to +85°C Temp=-20°C to +85°C, V _{CC} =3.2V to 4.8V
Gain Temperature Coefficient		28.0		dB	
EVM RMS		-0.03		db/°	P _{OUT} ≤28.5dBm P _{OUT} ≤26.5dBm, V _{CC} =3.2V to 4.8V, ≤2.5:1 VSWR, All angles
		2.0	3.5	%	
ACPR and Spectrum Mask				%	At 200kHz in 30kHz BW, P _{OUT} ≤28.5dBm At 400kHz in 30kHz BW, P _{OUT} ≤28.5dBm At 600kHz to 1800kHz in 30kHz BW, P _{OUT} ≤28.5dBm
		-36	-34	dBc	
		-60	-56	dBc	
Output Noise Power		-85	-84	dBm	At 600kHz to 1800kHz in 30kHz BW, P _{OUT} ≤28.5dBm RBW=100kHz, 935MHz to 960MHz, P _{OUT} ≥+5dBm
Forward Isolation			-25	dBm	TX Enable=0V, V _{RAMP} = 0.2V, P _{IN} =+6dBm Over all power levels Over all power levels
Second Harmonic			-7	dBm	
Third Harmonic			-7	dBm	
All other Non-Harmonic Spurious			-36	dBm	
Input Impedance		50		Ω	
Input VSWR			2.5:1		Over all power levels
Output Load VSWR		6:1			Spurious<-36dBm, V _{RAMP} =0.2V to 1.6V, RBW=3MHz
Output Load Ruggedness		10:1			
Output Load Impedance		50		Ω	Load impedance presented at RF OUT pad

RF3145

Parameter	Specification			Unit	Condition
	Min.	Typ.	Max.		
Overall (DCS/PCS Mode) GMSK Mode					Temp=+25 °C, V _{CC} =3.5V, P _{IN} =+4dBm BandSelect=High, V _{RAMP} =V _{RAMP,MAX} , Freq=1710MHz to 1910MHz, 25% Duty Cycle, Pulse Width=1154μs
Operating Frequency Range	1710		1910	MHz	
Maximum Output Power	+32	+33		dBm	Temp=+25 °C, V _{CC} =3.5V, V _{RAMP} =1.6V, 1710MHz to 1785MHz
	31.5	32.5		dBm	1850MHz to 1910MHz
		30		dBm	Temp=+85°C, V _{BATT} =3.0V, V _{RAMP} =V _{RAMP_MAX}
Total Efficiency (PAE)	43	49		%	At P _{OUT,MAX} , V _{CC} =3.5V, 1710MHz- 1785MHz
		45		%	1850MHz-1910MHz
Recommended Input Power Range	+2	+4	+6	dBm	
Folding Conversion Gain		-5		dB	F ₀ =849MHz, other signal 829MHz at -40dBm, measured at 869MHz in 100kHz RBW (Max Power)
Output Noise Power (DCS)		-80	-77	dBm	F ₀ =1785, RBW=100kHz, 1805MHz to 1880MHz
Output Noise Power (PCS)		-80	-77	dBm	F ₀ =1910, RBW=100kHz, 1930MHz to 1990MHz
Forward Isolation		-37	-30	dBm	TX Enable=0V, V _{RAMP} =0.2, P _{IN} =+6dBm
Second Harmonic			-7	dBm	Over all power levels
Third Harmonic			-7	dBm	Over all power levels
All other Non-Harmonic Spurious			-36	dBm	
Cross Band Coupling 2F ₀		-60	-30	dBm	
Input Impedance		50		Ω	
Input VSWR			2.5:1		Over all power levels
Output Load VSWR		6:1			Spurious<-36dBm, V _{RAMP} =0.2V to 1.6V RBW=3MHz
Output Load Ruggedness		10:1			
Output Load Impedance		50		Ω	Load impedance presented at the PCS/DCS RF OUT PIN
Power Control V_{RAMP} DCS/PCS GMSK					
Power Control "ON"			1.6	V	Max. P _{OUT} , Voltage supplied to the input
Power Control "OFF"		0.2	0.25	V	Min. P _{OUT} , Voltage supplied to the input
Power Control Range		33		dB	V _{RAMP} =0.2V to 1.6V
V _{RAMP} Input Capacitance		15		pF	DC to 2MHz
V _{RAMP} Input Current			10	μA	V _{RAMP} =1.6V
Turn On/Off Time			4	μs	V _{RAMP} =0V to 1.6V

Parameter	Specification			Unit	Condition
	Min.	Typ.	Max.		
1710MHz to 1785MHz 8PSK Mode					Temp=25°C, V _{CC} =3.5V, BandSelect=High, Freq=1710MHz to 1785MHz, P _{IN} =+4dBm V _{RAMP} =V _{RAMP,MAX} , 25% Duty Cycle, Pulse Width=1154µs
Operating Frequency Range	1710		1785	MHz	
Output Power to Meet EVM and ACPR Spectrum	27.5	28.0		dBm	Temp=25°C, V _{CC} =3.5V, Freq=1710MHz to 1785MHz, V _{RAMP} =V _{RAMP,MAX}
	25.5			dBm	Temp=-20°C to +85°C, V _{CC} =3.2V
Total Efficiency (PAE)		25		%	At P _{OUT,MAX} V _{CC} =3.5V
Gain	32.5	36	37.5	dB	
		34.5		dB	Temp=-20°C to +85°C
Gain Temperature Coefficient		-0.03		dB/°	Temp=-20°C to +85°C, V _{CC} =3.2V to 4.8V
EVM		2.0	3.5	%	P _{OUT} ≤27.5dBm
			5.0	%	P _{OUT} ≤25.5dBm, V _{CC} =3.2V to 4.8V, ≤2.5:1 VSWR, All angles
ACPR and Spectrum Mask		-36	-34	dBc	At 200kHz in 30kHz BW, P _{OUT} ≤27.5dBm
		-58	-56	dBc	At 400kHz in 30kHz BW, P _{OUT} ≤27.5dBm
			-63	dBc	At 600kHz to 1800kHz in 30kHz BW, P _{OUT} ≤27.5dBm
Output Noise Power (DCS)		-80	-77	dBm	F ₀ =1785, RBW=100kHz, 1805MHz to 1880MHz
Forward Isolation			-30	dBm	TX Enable=0V, V _{RAMP} =0.2, P _{IN} =+6dBm
Second Harmonic			-7	dBm	Over all power levels
Third Harmonic			-7	dBm	Over all power levels
All other Non-Harmonic Spurious			-36	dBm	
Input Impedance		50		Ω	
Input VSWR			2.5:1		Over all power levels
Output Load VSWR		6:1			Spurious<-36dBm, V _{RAMP} =0.2V to 1.6V RBW=3MHz
Output Load Ruggedness		10:1			
Output Load Impedance		50		Ω	Load impedance presented at the DCS RF OUT PIN

RF3145

Parameter	Specification			Unit	Condition
	Min.	Typ.	Max.		
1850MHz to 1910MHz 8PSK Mode					Temp=25°C, V _{CC} =3.5V, BandSelect=High, Freq=1850MHz to 1910MHz, V _{RAMP} =V _{RAMP,MAX} , 25% Duty Cycle, Pulse Width=1154μs
Operating Frequency Range	1850		1910	MHz	
Output Power to Meet EVM and ACPR Spectrum	27.5	28.0		dBm	Temp=25°C, V _{CC} =3.5V, Freq=1850MHz to 1910MHz, V _{RAMP} =V _{RAMP,MAX}
	25.5			dBm	Temp=-20°C to +85°C, V _{CC} =3.2V
Total Efficiency (PAE)		25		%	At P _{OUT,MAX} V _{CC} =3.5V
Gain	32.50	35.5	37.5	dB	
		34.0		dB	
Gain Temperature Coefficient		-0.03		dB/°	Temp=-20°C to +85°C
EVM		2.0	3.5	%	Temp=-20°C to +85°C, V _{CC} =3.2V to 4.8V
			5.0	%	P _{OUT} ≤27.5dBm
ACPR and Spectrum Mask		-36	-34	dBc	P _{OUT} ≤25.5dBm, V _{CC} =3.2V to 4.8V, ≤2.5:1 VSWR, All angles
		-58	-56	dBc	At 200kHz in 30kHz BW, P _{OUT} ≤27.5dBm
			-63	dBc	At 400kHz in 30kHz BW, P _{OUT} ≤27.5dBm
				dBc	At 600kHz to 1800kHz in 30kHz BW, P _{OUT} ≤27.5dBm
Output Noise Power (PCS)		-80	-77	dBm	F ₀ =1910, RBW=100kHz, 1930MHz to 1990MHz
Forward Isolation			-30	dBm	TX Enable=0V, V _{RAMP} =0.2, P _{IN} =+6dBm
Second Harmonic			-7	dBm	Over all power levels
Third Harmonic			-7	dBm	Over all power levels
All other Non-Harmonic Spurious			-36	dBm	
Input Impedance		50		Ω	
Input VSWR			2.5:1		Over all power levels
Output Load VSWR		6:1			Spurious<-36dBm, V _{RAMP} =0.2V to 1.6V RBW=3MHz
Output Load Ruggedness		10:1			
Output Load Impedance		50		Ω	Load impedance presented at the PCS RF OUT PIN
Overall Power Supply					
Power Supply Voltage	3.0	3.5	4.8	V	Specifications
	3.0		4.3	V	Nominal operating limits, P _{OUT} <+33dBm
Power Supply Current		2.0		A	50% Duty Cycle, pulse width=2308μs
		1	10	μA	DC Current at P _{OUT,MAX}
V _{MODE} Voltage "Low"	0.0	0.0	0.7	V	P _{IN} <-30dBm, V _{RAMP} =0V, Temp=-40°C to +85°C
V _{MODE} Voltage "High"	1.5	2.8	3.0	V	

Note: V_{RAMP,MAX}=3/8*V_{BATT}+0.18≤1.6V

Pin	Function	Description	Interface Schematic
1	DCS/PCS IN	RF input to the DCS/PCS band. This is a 50Ω input.	
2	BAND SELECT	Allows external control to select the GSM or DCS/PCS band with a logic high or low. A logic low enables the GSM band whereas a logic high enables the DCS/PCS band.	
3	TX ENABLE	This signal enables the PA module for operation with a logic high. Once TX Enable is asserted the RF output level will increase to 0dBm.	
4	VBATT	Power supply for the module. This should be connected to the battery.	
5	VMODE	This signal selects 8PSK mode with a logic "high" (1.5V to 3.0V), and selects GMSK mode with a logic "low" (0V to 0.7V). When the VMODE switch is enabled "high", the gain in the GSM band is reduced by bypassing the first stage amplifier. When the VMODE is "low", all stages are active.	
6	VRAMP	Ramping signal from DAC. A simple RC filter may need to be connected between the DAC output and the V _{RAMP} input depending on the baseband selected. The ramping profiles shown later in the data sheet are recommended profiles for meeting the GSM specification for burst timing and transient spectrum.	
7	GSM IN	RF input to the GSM band. This is a 50Ω input.	
8	NC	Not connected.	
9	GSM OUT	RF output for the GSM band. This is a 50Ω output. The output load line matching is contained internal to the package.	
10	NC	Not connected.	
11	DCS/PCS OUT	RF output for the DCS/PCS band. This is a 50Ω output. The output load line matching is contained internal to the package.	
12	NC	Not connected.	
Pkg Base	GND		

Pin Out

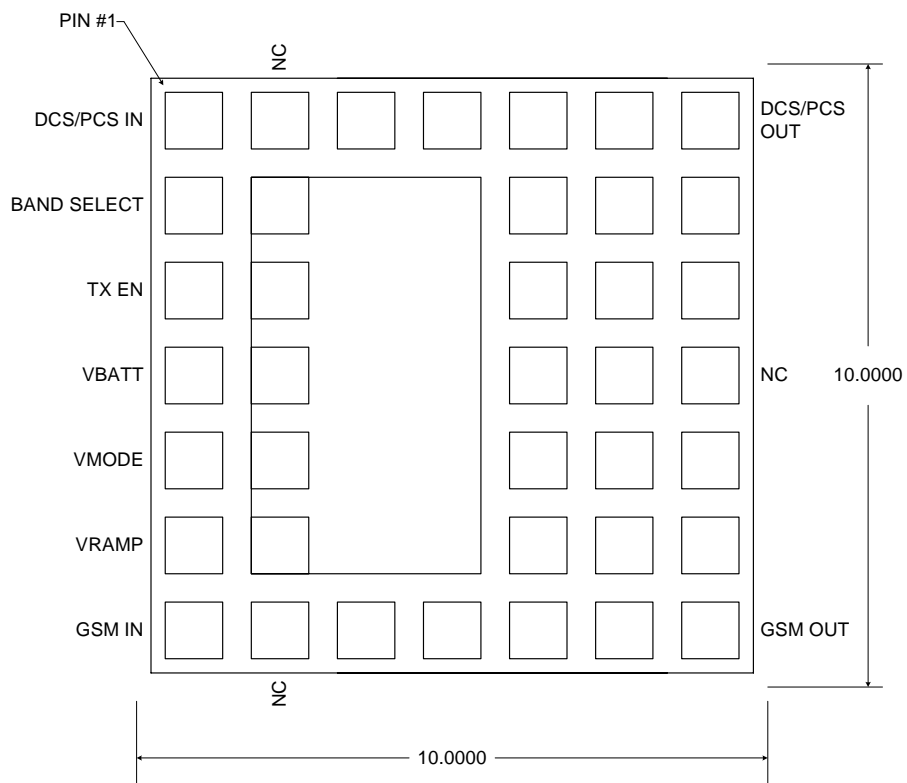

Application Schematic

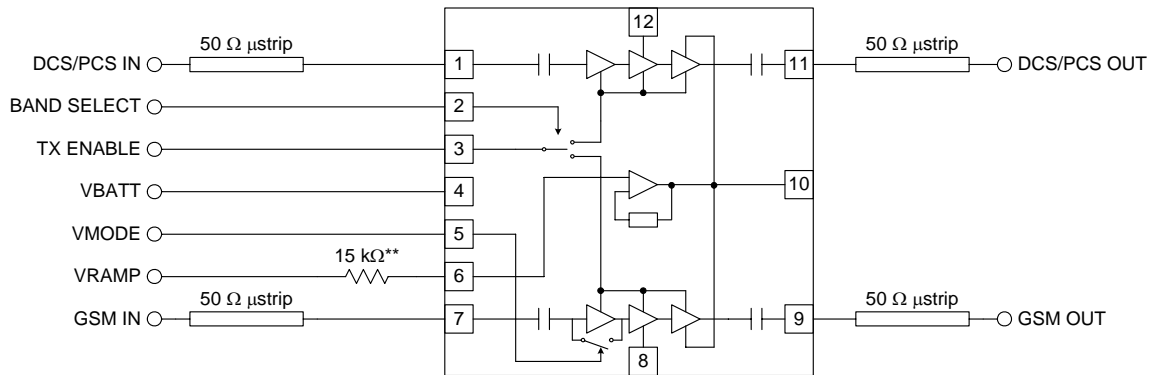

** Used to filter noise and spurious from base band.

Evaluation Board Schematic

(Download [Bill of Materials](http://www.rfmd.com) from www.rfmd.com.)

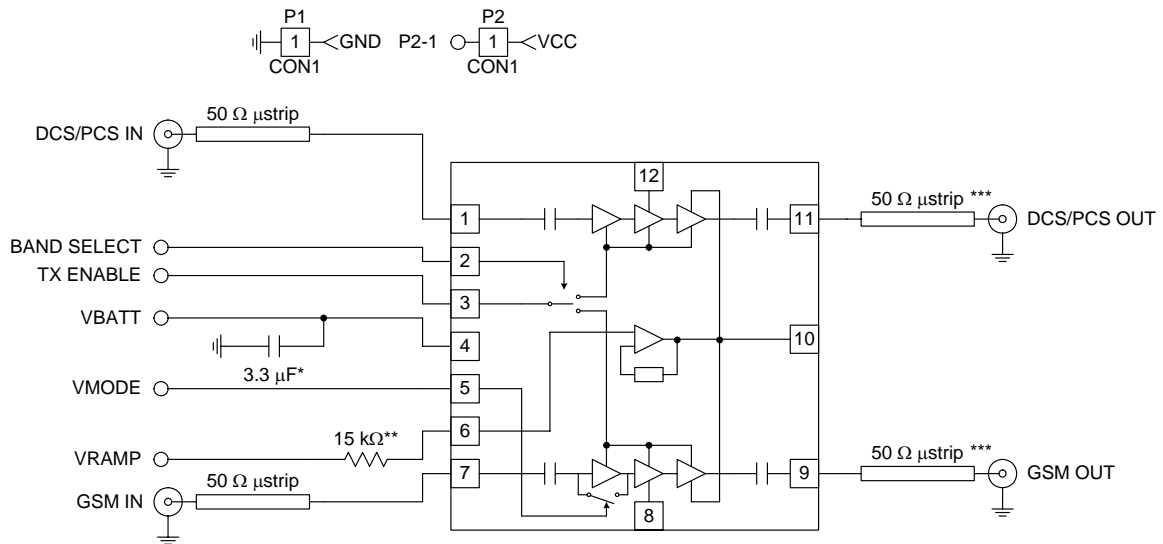

- *Not required in most applications.
- ** Used to filter noise and spurious from baseband.
- *** 0.05 dB loss for GSM
0.15 dB loss for DCS

RF3145

Dual Mode Operation

MODE	RF INPUT	V _{RAMP}	TX ENABLE	V _{MODE}
GSM	FIXED	Ramp from 0.2V to 1.6V (GSM Burst Ramp Signal)	High (Normal) Low (Isolation)	Low
EDGE	Linear ramp from AGC Amplifier/Source (GSM Burst Ramp Signal)	FIXED	High (Normal) Low (Isolation)	High

RF3145 Power Amplifier Simplified Block Diagram of a Single Band

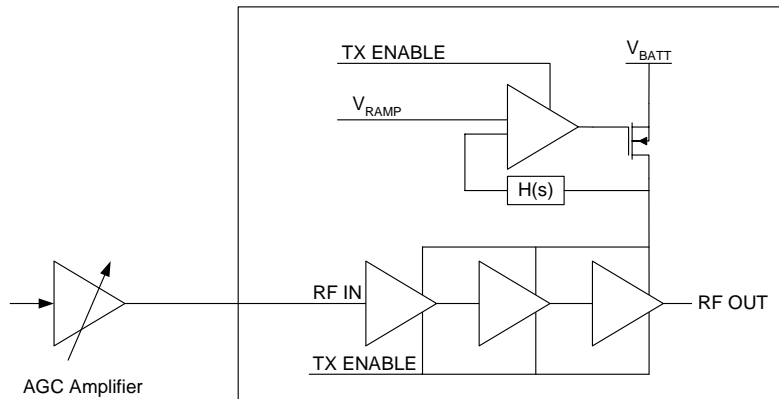

Power On Sequence

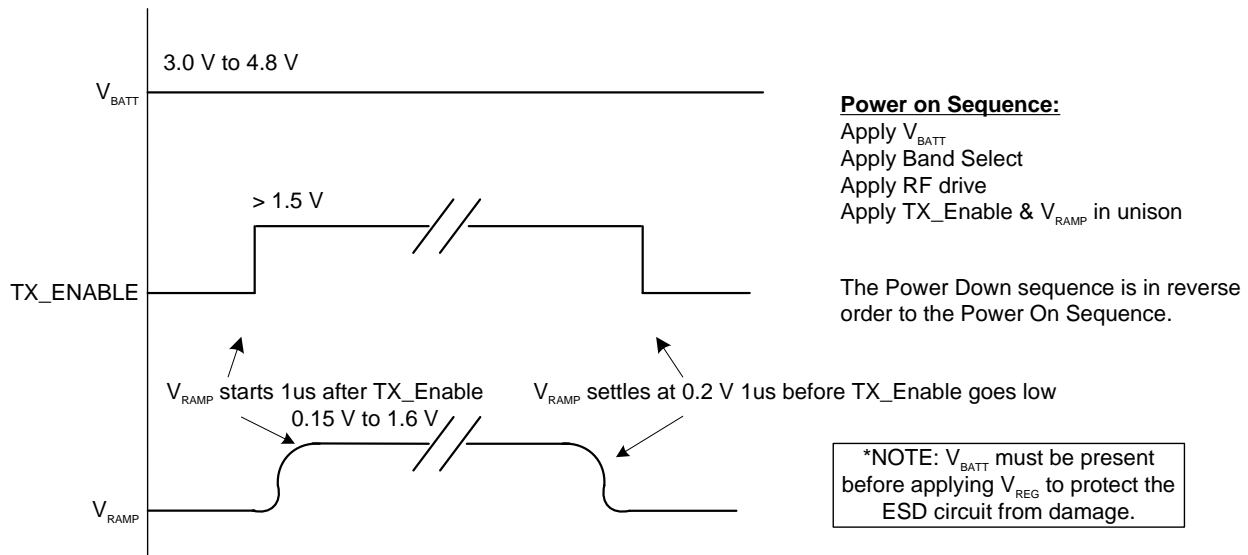

Theory of Operation

Overview

The RF3145 is a dual-mode, quad-band power amplifier module that is compatible with both GSM and EDGE applications. The device operates in a broad frequency range that includes the GSM850, GSM900, DCS1800, and PCS1900 frequency bands. Integrated band select, mode select, and power control features are also integrated to provide digital control of various features.

Band select provides digital selection of the GSM850/900 or DCS1800/PCS1900 band. V_{MODE} provides digital control of the gain in the GSM900 band. Due to gain expansion at input powers below the 1 dB compression point, low gain mode is provided to maintain the noise power performance in EDGE applications. However, this feature is not required in the DCS1800/PCS1900 bands. Therefore, V_{MODE} controls only the gain in the GSM850/900 band. (This feature is not provided in the DCS/PCS band.)

The integrated power control feature employs an indirect closed loop method that uses collector control to regulate output power. Collector control design architecture has several advantages, including simplifying the phone design, as well as minimizing gain and linearity variation in EDGE applications. Integrated power control eliminates the need for a complicated control loop design. The indirect closed loop is fully self-contained and does not require loop optimization. It can be driven directly from the DAC output in the baseband circuit.

The RF3145 mode of operation is a function of the input power level and the V_{MODE} logic level. In GSM applications, the input power is held constant in the range of +2dBm to +5dBm, and the output power is controlled using the V_{RAMP} input. The required input power for GSM/GPRS applications is typically 3dB to 4dB higher than the 1dB compression point. GSM/GPRS applications use GMSK modulation, which is constant envelope and is not sensitive to amplitude non-linearities. Therefore the power amplifier may be operated in deep class AB which offers high efficiency. However, in EDGE applications, the $3\pi/8$ rotated 8-PSK constellation shown in Figure 1 contains both phase and amplitude information.

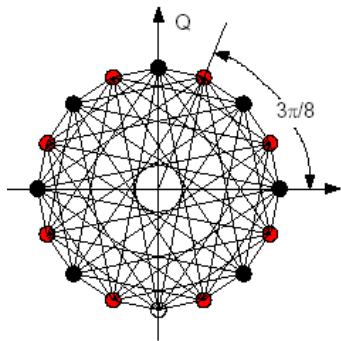

Figure 1. EDGE $3\pi/8$ Rotated 8-PSK Constellation

Therefore, EDGE applications require a linear power amplifier to transfer EDGE modulation with minimal distortion. Changing V_{RAMP} in linear applications will cause distortion to the EDGE modulated signal, and is not recommended. If the V_{RAMP} signal is lowered in EDGE applications, the voltage on the collectors of the power amplifiers will also be lowered (lower than the 1dB compression point). In EDGE applications, the V_{RAMP} input should be held constant at $V_{RAMP(MAX)}$, and the input power is ramped to meet the EDGE burst mask. Typical EDGE systems use a VGA to provide this RF ramp input to the power amplifier.

RF3145

Theory of Operation

The indirect closed loop is essentially a closed loop method of power control that is invisible to the user. Most power control systems in GSM sense either forward power or collector/drain current. The RF3145 does not use a power detector. A high-speed control loop is incorporated to regulate the collector voltages of the amplifier while the stages are held at a constant bias. The V_{RAMP} signal is multiplied and the collector voltages are regulated to the multiplied V_{RAMP} voltage. The basic circuit is shown in the following diagram.

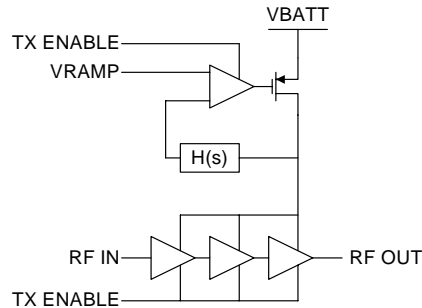

By regulating the power, the stages are held in saturation across all power levels. As the required output power is decreased from full power down to 0dBm, the collector voltage is also decreased. This regulation of output power is demonstrated in Equation 1 where the relationship between collector voltage and output power is shown. Although load impedance affects output power, supply fluctuations are the dominate mode of power variations. With the RF3145 regulating collector voltage, the dominant mode of power fluctuations is eliminated.

$$P_{dBm} = 10 \cdot \log \left[\frac{(2 \cdot V_{CC} - V_{SAT})^2}{8 \cdot R_{LOAD} \cdot 10^{-3}} \right] \quad (\text{Eq. 1})$$

There are several key factors to consider in the implementation of a transmitter solution for a mobile phone. Some of them are:

- Effective efficiency (η_{EFF})
- Current draw and system efficiency
- Power variation due to Supply Voltage
- Power variation due to frequency
- Power variation due to temperature
- Input impedance variation
- Noise power
- Loop stability
- Loop bandwidth variations across power levels
- Burst timing and transient spectrum trade-offs
- Harmonics

Talk time and power management are key concerns in transmitter design since the power amplifier has the highest current draw in a mobile terminal. Considering only the power amplifier's efficiency does not provide a true picture for the total system efficiency. It is important to consider effective efficiency which is represented by η_{EFF} . (η_{EFF} considers the loss between the PA and antenna and is a more accurate measurement to determine how much current will be drawn in the application). η_{EFF} is defined by the following relationship (Equation 2):

$$\eta_{EFF} = \frac{\sum_{n=1}^m P_N - P_{IN}}{P_{DC}} \cdot 100 \quad (\text{Eq. 2})$$

Where P_N is the sum of all positive and negative RF power, P_{IN} the input power and P_{DC} is the delivered DC power. In dB the formula becomes (Equation 3):

$$\eta_{EFF} = \frac{10^{\frac{P_{PA} + P_{LOSS}}{10}} - 10^{\frac{P_{IN}}{10}}}{V_{BAT} \cdot I_{BAT} \cdot 10} \quad (\text{Eq. 3})$$

Where P_{PA} is the output power from the PA, P_{LOSS} the insertion loss, P_{IN} the input power to the PA, and P_{DC} the delivered DC power.

The RF3145 improves the effective efficiency by minimizing the P_{LOSS} term in the equation. A directional coupler may introduce 0.4dB to 0.5dB loss to the transit path. To demonstrate the improvement in effective efficiency consider the following example:

Conventional PA Solution:

$$\begin{array}{l} P_{PA} = +33.5 \text{ dBm} \\ P_{IN} = +3 \text{ dBm} \\ P_{LOSS} = -0.4 \text{ dB} \\ V_{BAT} = 3.5 \text{ V} \\ I_{BAT} = 1.16 \text{ A} \end{array} \quad \Rightarrow \quad \eta_{EFF} = 50.3\%$$

RF3145 Solution:

$$\begin{array}{l} P_{PA} = +33.5 \text{ dBm} \\ P_{IN} = +3 \text{ dBm} \\ P_{LOSS} = 0 \text{ dB} \\ V_{BAT} = 3.5 \text{ V} \\ I_{BAT} = 1.16 \text{ A} \end{array} \quad \Rightarrow \quad h_{EFF} = 55.16\%$$

The RF3145 solution improves effective efficiency 5percent.

Output power does not vary due to supply voltage under normal operating conditions if V_{RAMP} is sufficiently lower than V_{BATT} . By regulating the collector voltage to the PA, the voltage sensitivity is essentially eliminated. This covers most cases where the PA will be operated. However, as the battery discharges and approaches its lower power range, the maximum output power from the PA will also drop slightly. In this case it is important to also decrease V_{RAMP} to prevent the power control from inducing switching transients. These transients occur as a result of the control loop slowing down and not regulating power in accordance with V_{RAMP} .

The switching transients due to low battery conditions are regulated by incorporating the following relationship limiting the maximum V_{RAMP} voltage (Equation 4). Although no compensation is required for typical battery conditions, the battery compensation required for extreme conditions is covered by the relationship in Equation 4. This should be added to the terminal software.

$$V_{RAMP} \leq \frac{3}{8} \cdot V_{BATT} + 0.18 \quad (\text{Eq. 4})$$

NOTE: Output power is limited by battery voltage. The relationship in Equation 4 does not limit output power. Equation 4 limits the V_{RAMP} voltage to correspond with the battery voltage.

Due to reactive output matches, there are output power variations across frequency. There are a number of components that can make the effects greater or less.

RF3145

The components following the power amplifier often have insertion loss variation with respect to frequency. Usually, there is some length of microstrip following the power amplifier. There is also a frequency response found in directional couplers due to variation in the coupling factor over frequency, as well as the sensitivity of the detector diode. Since the RF3145 does not use a directional coupler with a diode detector, these variations do not occur.

Input impedance variation is found in most GSM power amplifiers. This is due to a device phenomena where C_{BE} and C_{CB} (C_{GS} and C_{SG} for a FET) vary over the bias voltage. The same principle used to make varactors is present in the power amplifiers. The junction capacitance is a function of the bias across the junction. This produces input impedance variations as the V_{APC} voltage is swept. Although this could present a problem with frequency pulling the transmit V_{CO} off frequency, most synthesizer designers use very wide loop bandwidths to quickly compensate for frequency variations due to the load variations presented to the V_{CO} .

The RF3145 presents a very constant load to the V_{CO} . This is because all stages of the RF3145 are run at constant bias. As a result, there is constant reactance at the base emitter and base collector junction of the input stage to the power amplifier.

Noise power in PA's where output power is controlled by changing the bias voltage is often a problem when backing off of output power. The reason is that the gain is changed in all stages and according to the noise formula (Equation 5),

$$F_{TOT} = F1 + \frac{F2 - 1}{G1} + \frac{F3 - 1}{G1 \cdot G2} \quad (\text{Eq. 5})$$

the noise figure depends on noise factor and gain in all stages. Because the bias point of the RF3145 is kept constant, the gain in the first stage is always high and the overall noise power is not increased when decreasing output power.

Power control loop stability often presents many challenges to transmitter design. Designing a proper power control loop involves trade-offs affecting stability, transient spectrum and burst timing.

In conventional architectures, the PA gain (dB/V) varies across different power levels, and as a result the loop bandwidth also varies. With some power amplifiers it is possible for the PA gain (control slope) to change from 100dB/V to as high as 1000dB/V. The challenge in this scenario is keeping the loop bandwidth wide enough to meet the burst mask at low slope regions which often causes instability at high slope regions.

The RF3145 loop bandwidth is determined by internal bandwidth, and the RF output load and does not change with respect to power levels. This makes it easier to maintain loop stability with a high bandwidth loop since the bias voltage and collector voltage do not vary.

An often overlooked problem in PA control loops is that a delay not only decreases loop stability, it also affects the burst timing (for instance, when the input power from the V_{CO} decreases (or increases) with respect to temperature or supply voltage). The burst timing then appears to shift to the right, especially at low power levels. The RF3145 is insensitive to a change in input power and the burst timing is constant and requires no software compensation.

Switching transients occur when the up and down ramp of the burst is not smooth enough, or suddenly changes shape. If the control slope of a PA has an inflection point within the output power range, or if the slope is simply too steep, it is difficult to prevent switching transients. Controlling the output power by changing the collector voltage is (as described earlier) based on the physical relationship between voltage swing and output power. Furthermore all stages are kept constantly biased so inflection points are nonexistent.

RF3145

Harmonics are natural products of high efficiency power amplifier design. An ideal class “E” saturated power amplifier will produce a perfect square wave. Looking at the Fourier transform of a square wave reveals high harmonic content. Although this is common to all power amplifiers, there are other factors that contribute to conducted harmonic content as well. With most power control methods, a peak power diode detector is used to rectify and sense forward power. Through the rectification process, there is additional squaring of the waveform resulting in higher harmonics. The RF3145 addresses this by eliminating the need for the detector diode. Therefore, the harmonics coming out of the PA should represent the maximum power of the harmonics throughout the transmit chain. This is based on proper harmonic termination of the transmit port. The receive port termination on the T/R switch, as well as the harmonic impedance from the switch itself, will have an impact on harmonics. Should a problem arise, these terminations should be explored.

NOTE: Output power is limited by battery voltage. The relationship in Equation 4 does not limit output power. Equation 4 limits V_{RAMP} to correspond with the battery voltage.

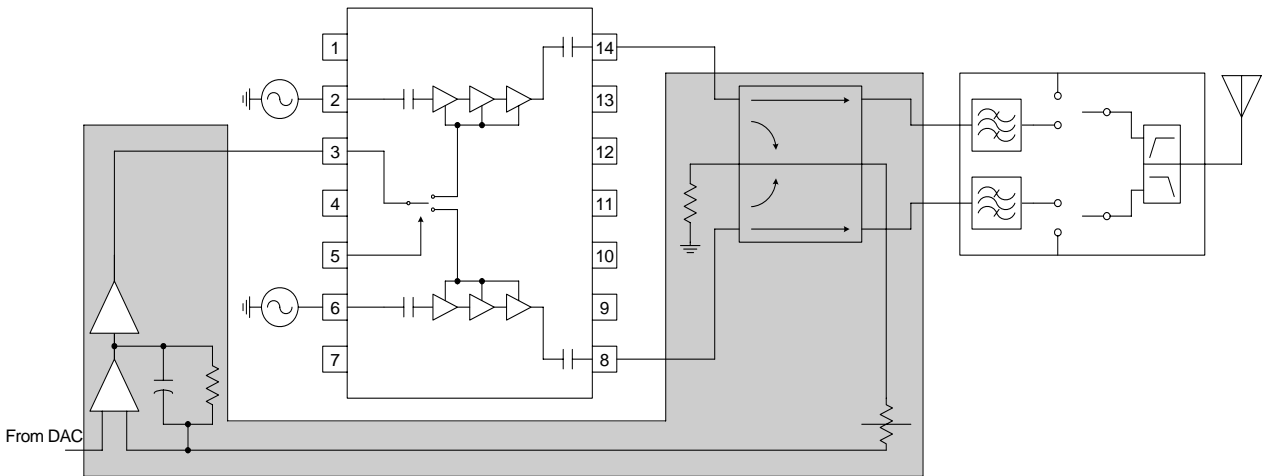

*Shaded area eliminated with Indirect Closed Loop using RF3145

PCB Design Requirements

PCB Surface Finish

The PCB surface finish used for RFMD's qualification process is electroless nickel, immersion gold. Typical thickness is 3μinch to 8μinch gold over 180μinch nickel.

PCB Land Pattern Recommendation

PCB land patterns are based on IPC-SM-782 standards when possible. The pad pattern shown has been developed and tested for optimized assembly at RFMD; however, it may require some modifications to address company specific assembly processes. The PCB land pattern has been developed to accommodate lead and package tolerances.

PCB Metal Land and Solder Mask Pattern

A = 0.80 Sq. Typ.
 B = 0.95 x 0.87 Typ.
 C = 0.87 x 0.95

Dimensions in mm.

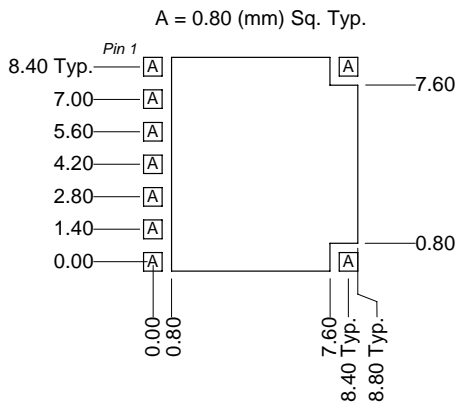

Metal Land Pattern

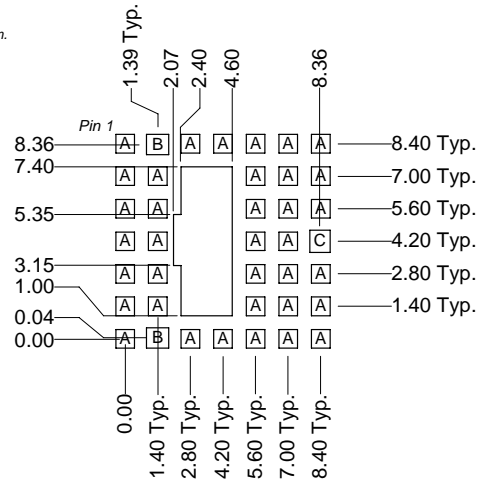

Solder Mask Pattern