



SA9109B

MONOCHIP SINGLE PHASE BIDIRECTIONAL KILOWATT HOUR METERING IC

FEATURES

- Performs bidirectional energy metering and directly drives a LCD with 7 digits display plus annunciators
- Programmable method of energy addition
- Pin compatible with SAMES SA9109A
- 4 externally selectable on-chip tariff registers
- An additional total energy register
- Meets the IEC 521/1036 Specification requirements for Class 1 AC Watt hour meters
- Optical interface for electronic reading according to IEC1107 Mode D
- Pulse output for calibration
- Power consumption rating below 40mW
- Adaptable to different types of current sensors
- Operates over a wide temperature range
- Precision voltage reference on-chip
- Protected against ESD

DESCRIPTION

The SAMES SA9109B Single Phase bidirectional energy metering integrated circuit has an integrated Liquid Crystal Display (LCD) driver for a 7 digit (7 segment) display as well as 4 multiple tariff registers. The SA9109B performs the active power calculation.

The method of calculation takes the power factor into account.

Two methods of energy measurement are available. One method results in energy values which take the direction of energy flow into account, a summation of signed integers. The alternative method measures energy regardless of the direction of energy flow, a summation of absolute values. The required measurement method may be selected when writing to the RAM of the device.

PIN CONNECTIONS

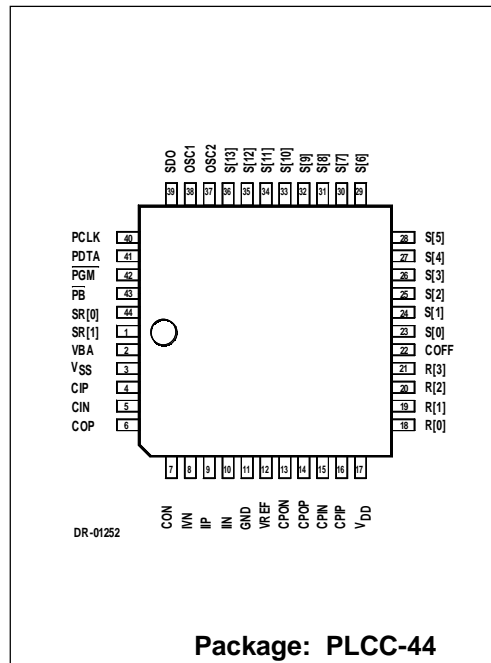

SA9109B

DESCRIPTION (continued)

The measured energy is displayed in kiloWatt hours (kWh). The SA9109B is capable of driving a display having a resolution of 1/10 kWh.

This innovative universal energy metering integrated circuit is ideally suited for energy measurement in single phase systems.

The SA9109B integrated circuit is available in a 44 pin plastic leaded chip carrier (PLCC-44) package type.

BLOCK DIAGRAM

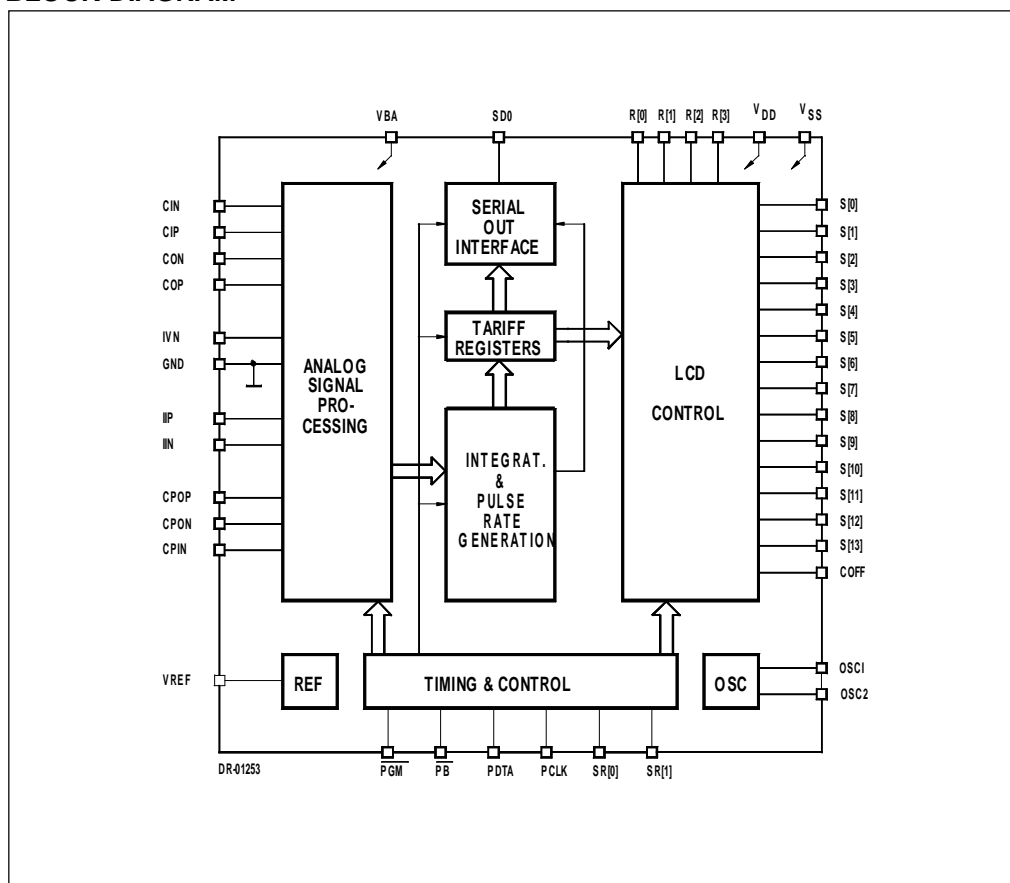

ABSOLUTE MAXIMUM RATINGS*

Parameter	Symbol	Min	Max	Unit
Supply Voltage	$V_{DD} - V_{SS}$	-0.3	6.0	V
Current on any pin	I_{PIN}	-150	+150	mA
Storage Temperature	T_{STG}	-40	+125	°C
Operating Temperature	T_O	-40	+85	°C

* Stresses above those listed under “Absolute Maximum Ratings” may cause permanent damage to the device. This is a stress rating only. Functional operation of the device at these or any other condition above those indicated in the operational sections of this specification, is not implied. Exposure to Absolute Maximum Ratings for extended periods may affect device reliability.

ELECTRICAL CHARACTERISTICS

($V_{DD} = 2.5V$, $V_{SS} = -2.5V$, over the temperature range $-10^{\circ}C$ to $+70^{\circ}C^{\#}$, unless otherwise specified.)

Parameter	Symbol	Min	Typ	Max	Unit	Condition
Operating temperature range #	T_O	-25		+85	°C	
Supply Voltage: Positive	V_{DD}	2.25		2.75	V	
Supply Voltage: Negative	V_{SS}	-2.75		-2.25	V	
Supply Current: Positive	I_{DD}		7	10	mA	
Supply Current: Negative	I_{SS}		7	10	mA	
Current Sensor Inputs (Differential)						
Input Current Range	I_{II}	-25		+25	µA	
Voltage Sensor Inputs (Asymmetric)						
Input current Range	I_{IV}	-25		+25	µA	
LCD backplane Voltage	V_B		V_{DD} & V_{SS}		V	R[0] ... R3]
LCD segment Voltage	V_S		$1/3V_{DD}$ $2/3V_{DD}$		V	S[0] ...S[15]
Pin SDO Pulse rate	f_P		3.5	35	Hz Hz	Default ¹ Programmed ¹
Pulse width Output Low Voltage Output High Voltage	t_P V_{OL} V_{OH}	4.3 $V_{DD}-1$		5.9 $V_{SS}+1$	mS V V	$I_{OL} = 5mA$ $I_{OH} = -2mA$
Oscillator	Recommended crystal: TV colour burst crystal $f = 3.5795$ MHz					

ELECTRICAL CHARACTERISTICS (continued)

Parameter	Symbol	Min	Typ	Max	Unit	Condition
Pin VREF Ref. Current Ref. Voltage	$-I_R$ V_R	45 1.1	50	55 1.3	μA V	With $R_7 = 24\text{k}\Omega$ connected to V_{SS} Referred to V_{SS}
Pins $\overline{\text{PB}}$, SR[0], SR[1], PGM Input Voltage High Input Voltage Low Pullup Current	V_{IH} V_{IL}	4	30	1	V V μA	$V_{IN} = V_{SS}$
Pin PCLK Input Voltage High Input Voltage Low Input Current High/ Low	V_{IH} V_{IL}	4	± 30	1	V V μA	$V_{IN} = V_{SS} \cdot V_{DD}$
Pin VBA	I_{MAX} V_{MIN}	1.1		50 5.5	nA V	Power down mode

Extended Operating Temperature Range available on request

Note 1: At rated conditions

PIN DESCRIPTION

Pin	Designation	Type	Description
11	GND	Supply	Ground
17	V_{DD}	Supply	Positive Supply Voltage sense
3	V_{SS}	Supply	Negative Supply Voltage sense
2	VBA	Supply	Battery back-up. Negative Supply Voltage
8	IVN	Analog in	Analog input for Voltage
10	IIN	Analog in	Analog input for Current
9	IIP	Analog in	
38	OSC1	Input	Connections for crystal or ceramic resonator (OSC1 = Input; OSC2 = Output)
37	OSC2	Output	
18	R[0]	Output	Liquid crystal display (LCD) backplane drivers
19	R[1]	Output	
20	R[2]	Output	
21	R[3]	Output	



PIN DESCRIPTION (continued)

Pin	Designation	Type	Description
23	S[0]	Output	Liquid crystal display (LCD) segment drivers
24	S[1]	Output	
25	S[2]	Output	
26	S[3]	Output	
27	S[4]	Output	
28	S[5]	Output	
29	S[6]	Output	
30	S[7]	Output	
31	S[8]	Output	
32	S[9]	Output	
33	S[10]	Output	
34	S[11]	Output	
35	S[12]	Output	
36	S[13]	Output	
22	COFF	Output	Connection for all unused LCD segments, to ensure off status
7	CON	Analog	Connections for outer loop capacitor of A/D converter (Current)
6	COP	Analog	
5	CIN	Analog	Connections for inner loop capacitor of A/D converter (Current)
4	CIP	Analog	
16	CPIP	Analog	Connections for inner loop capacitor of A/D converter (Voltage)
15	CPIN	Analog	
14	CPOP	Analog	Connections for outer loop capacitor of A/D converter (Voltage)
13	CPON	Analog	
12	VREF	Analog	Connection for reference current setting resistor
39	SDO	Open drain	Pulse rate output. Serial data output when PB is low
44	SR[0]	Input	Control for tariff register selection (on-chip pull-up)
1	SR[1]	Input	Control for tariff register selection (on-chip pull-up)
43	PB	Input	Push Button: Display select/start serial data transmission on SDO (on-chip pull-up)
42	PGM	Input	Programming Mode. It is recommended that pin PGM be connected to V_{DD} via a 470 Ω resistor to guard against transients or noise
41	PDTA	Input	Programming Data (on-chip pull-down)
40	PCLK	Input	Programming Clock

FUNCTIONAL DESCRIPTION

The SA9109B is a CMOS mixed signal Analog/Digital integrated circuit, which performs power calculations across a power range of 1000:1, to an overall accuracy of better than Class 1. An on-chip LCD driver directly drives a 7 digit (7 segment) LCD display. Also included on-chip, are 4 tariff registers externally selectable for multi-tariff energy metering applications and a fifth register which retains the total energy consumption.

The integrated circuit includes all the required functions such as two oversampling A/D converters for the voltage and current sense inputs, power calculation and energy integration. Offset is eliminated through the use of internal cancellation procedures.

1. Power Calculation

In the Application Circuit (Figure 1), the voltage drop across the shunt will be between 0 and 16mV_{RMS} (0 to 80A through a shunt resistor of $200\mu\Omega$). This voltage is converted to a current of between 0 and $16\mu\text{A}_{\text{RMS}}$, by means of resistors R_1 and R_2 .

The current sense input saturates at an input current of $\pm 25\mu\text{A}$ peak.

The voltage level from the mains is divided down through a divider to 14V. This voltage is converted to a signal current of $14\mu\text{A}_{\text{RMS}}$ into the voltage sensor input.

A pulse rate output for calibration purposes is available on SDO (Pin 39), the pulse rate being proportional to the active energy consumption.

The integrated anti-creep function ensures no metering when no line current is present.

2. Analog Input Configuration

The input circuitry of the current and voltage sensor inputs are illustrated below.

These inputs are protected against electrostatic discharge through clamping diodes.

The feedback loops from the outputs of the amplifiers A_1 and A_v generate virtual shorts on the signal inputs. Exact duplications of the input currents are generated for the analog signal processing circuitry.

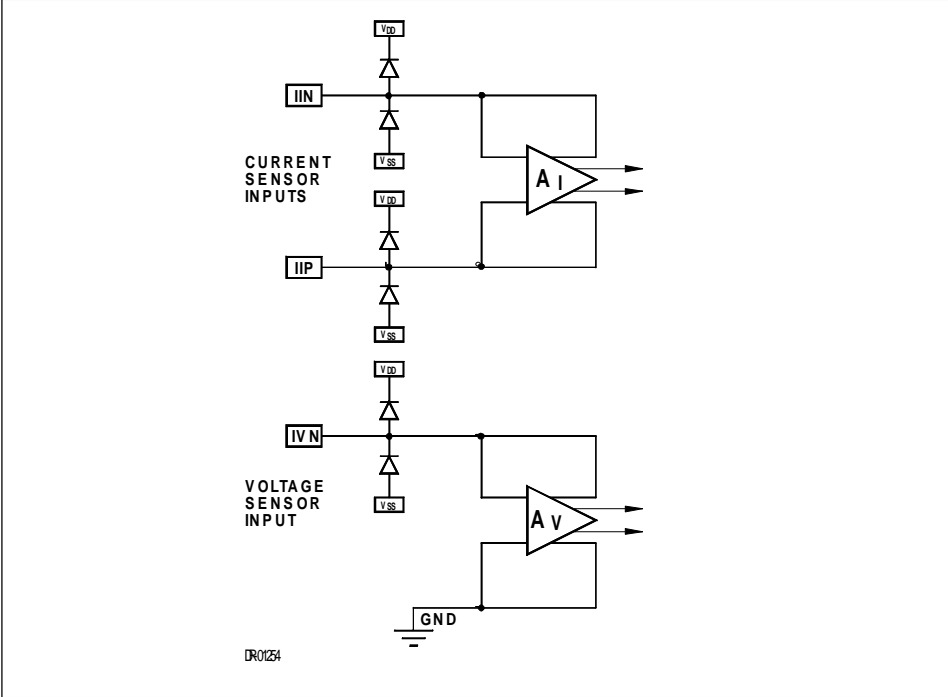

3. LCD Driver

The SA9109B has an on-chip LCD driver capable of driving a 4 backplane, 7 digit (7 segment) display, as well as 6 annunciators.

The backplane repetition frequency is approximately 90Hz.

The most significant digit is addressed by columns S[13] and S[12] and the least significant digit by S[1] and S[0]. Annunciators for the 4 tariff registers, the total register and energy direction are available on the 'h' segment of the 6 least significant digits. The display segments are addressed via the column outputs given in the table below:

LCD Segment Address Table

Digit	Column	R[0]	R[1]	R[2]	R[3]
10 ⁻¹ LSD	S[0]	Total	c	b	a
	S[1]	d	e	g	f
10 ⁰	S[2]	T4	c	b	a
	S[3]	d	e	g	f
10 ¹	S[4]	T3	c	b	a
	S[5]	d	e	g	f
10 ²	S[6]	T2	c	b	a
	S[7]	d	e	g	f
10 ³	S[8]	T1	c	b	a
	S[9]	d	e	g	f
10 ⁴	S[10]	Dir	c	b	a
	S[11]	d	e	g	f
10 ⁵ MSD	S[12]	h	c	b	a
	S[13]	d	e	g	f

LCD Layout

The LCD display is given in the diagram below:

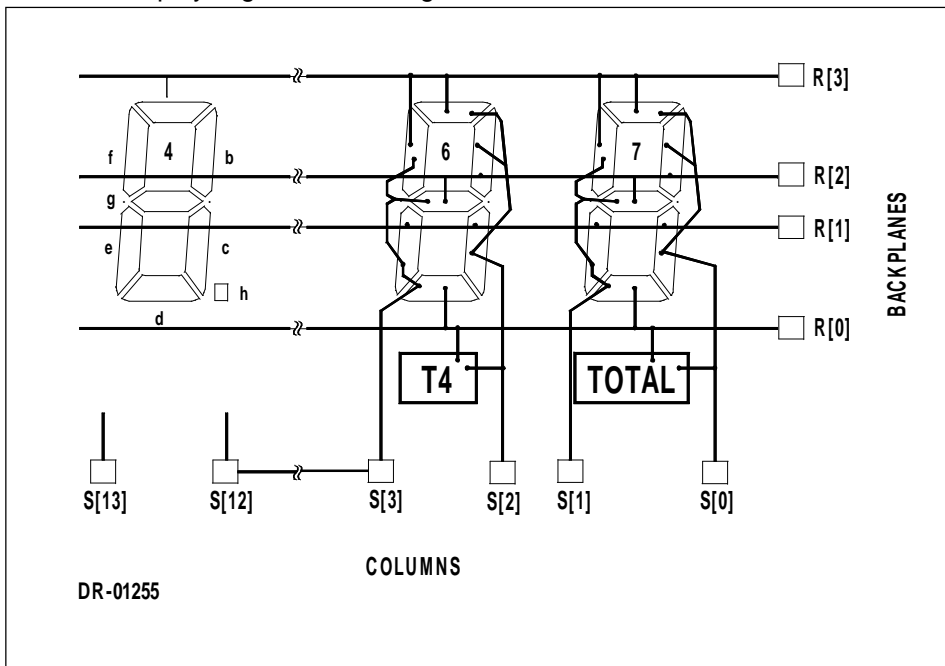

The kWh values of the LCD display digits, are given in the table below. The resolution of the Least Significant Digit is normally programmed to 0.1kWh:

10 ⁵	10 ⁴	10 ³	10 ²	10 ¹	10 ⁰	10 ⁻¹	kWh
-----------------	-----------------	-----------------	-----------------	-----------------	-----------------	------------------	-----

4. Device Programming

The SA9109B contains on-chip registers which enables the meter manufacturer to store various data:

Slope Adjustment

The slope of the device may be adjusted by programming a slope constant (K_s) into the device during calibration. The output frequency at SDO (f_p) is calculated by means of the following formula:

$$f_p = 11.16 * \frac{FOSC}{3.5795\text{MHz}} * \frac{I_I \cdot I_V}{I_R^2} * \frac{40062.5}{K_s}$$

Where

- FOSC = Oscillator frequency (2MHz 4MHz)
- I_I = Input current for current sensor input (16 μ A at rated line current)
- I_V = Input current for voltage sensor input (14 μ A at rated line voltage)
- I_R = Reference current (typically 50 μ A)
- K_s = Slope constant (1025 ... 16384)
(The default value is 11389)

By changing the slope of the device the resolution of the LCD, together with the pulse rate on SDO may be changed by up to an order. The block diagram below illustrates the display update rate.

Programmable slope divider

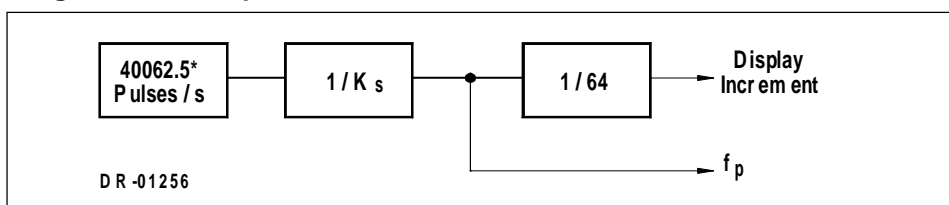

* At rated conditions

The display is incremented after every 64th pulse on SDO.

Display resolution

From the above formula for f_p it can be derived that the slope constant, K_s , is given by the following expression:

$$K_s = \frac{626 * 3600 * 1000 * E_{kWh}}{V_L * I_L}$$

Where

- E_{kWh} = energy for 1 display increment in kWh
- V_L = rated line voltage
- I_L = rated line current

This formula is valid only if $16\mu A_{RMS}$ flows into the current sense input for rated line current (I_L) and $14\mu A_{RMS}$ flows into the voltage sense input for rated line voltage (V_L).

Offset Adjustment

The precision of this device does not require any offset adjustment for Class 1 metering. This facility has been provided to compensate for poor PCB layout or circumstances requiring precision well beyond a Class 1 rating.

The offset of the device may be adjusted by programming a different offset into the device during calibration. To calculate the offset the following procedure should be followed:

Measure the linearity error at the current where offset correction is needed.

$$K_o = \frac{I_M * E_{RR}}{I_R * 6 * 10^{-6}}$$

- Where
- I_M = Measured current on the current sensor
 - I_R = Rated current on the current sensor
 - E_{RR} = Error ratio between the device and the Wh standard
 - K_o = Offset constant (-127 ...127)
(The default value is 0)

Note that K_o must be programmed as a integer value.

Meter/Manufacturers Identification Data

A total of eleven 4 bit words are available to store relevant data such as the meter and manufacturer identification codes. For the optical interface protocol, the 4-bit words are converted to 8-bit words (ASCII-format).

Writing to RAM

The memory is configured as ten 32 bit words. The programming data must be written to the device as a bitstream containing a total of 320 bits. ROM-locations will not be overwritten.



Word number	Bit number	Function	Description
1	31..28	Sign of Register 1	A '0' indicates a negative register value
1	27..0	Register 1	Contents of register 1 in binary coded decimal
2	31..28	Sign of Register 2	A '0' indicates a negative register value
2	27..0	Register 2	Contents of register 2 in binary coded decimal
3	31..28	Sign of Register 3	A '0' indicates a negative register value
3	27..0	Register 3	Contents of register 3 in binary coded decimal
4	31..28	Sign of Register 4	A '0' indicates a negative register value
4	27..0	Register 4	Contents of register 4 in binary coded decimal
5	31..28	Sign of Register 'Total'	A '0' indicates a negative register value
5	27..0	Register 'Total'	Registers 1, 2,3 and 4 are added and stored in the register 'Total'
6	31..16	ROM	Don't care
6	15..0	Manufacturers Identification	16 bits are available for the manufacturer of the metering system as a system identification
7	31..28	ROM	Don't care
7	27..0	System Identification	28 bits are available for the manufacturer of the metering system as a system identification
8	31..0	ROM	Don't care
9	31	Programmed slope select	Programmed slope select bit must be set if the default slope in ROM is not used
9	30..26	ROM	Don't care
9	25	Summation method select	0 to select addition which takes direction of energy flow into account 1 to select addition which does not take direction of energy flow into account
9	24..22	SAMES defined	Bits must be set to 0 for correct functionality
9	21	Sign of offset	By setting the sign bit a negative value is indicated
9	20..14	Offset	Offset of the device in binary
9	13..0	Slope	Slope of the device in binary. (default = 11389)
10	31..0	ROM	Don't care

The first bit of the programming data is written to word number 1, bit 31. The last bit is written to word number 10, bit 0.

Programming procedure:

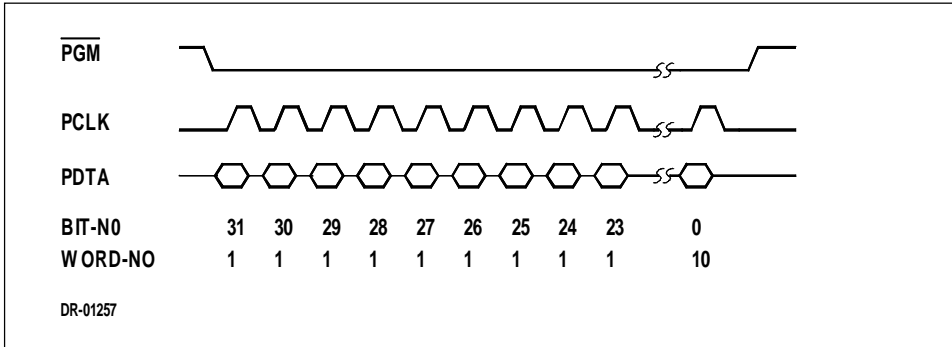

The $\overline{\text{PGM}}$ pin is pulled low and the PCLK pin should be clocked with an external clock. The programming data on the PDTA pin must be stable during the rising edge of the clock signal on PCLK.

The clock signal on PCLK should not exceed 200 kHz and does not have to be synchronised with the oscillator frequency (FOSC).

Programming mode is interrupted if PGM goes high.

Memory Reset

In programming mode (while $\overline{\text{PGM}}$ is pulled low) if PCLK is left floating and PDTA = 0, the internal clock of the SA9109B will ensure that default values are set. For default conditions all of the RAM locations are set to 0 and the value of the slope is set to 11389.

The minimum time period for a complete reset cycle is determined by:

$$t_{\min} = 322 * \frac{64}{\text{FOSC}}$$

Where FOSC = Oscillator frequency (2MHz.....4MHz)

If the recommended crystal frequency of 3.5795MHz is used, this will result in a minimum reset time of 5.8ms.

The specified signal levels on pins $\overline{\text{PGM}}$, PCLK and PDTA must remain stable for the entire reset cycle period.

5. Tariff Registers

A multiple tariff facility is provided on-chip by means of 4 tariff registers, which are externally selectable via the SR[0] and SR[1] inputs. The registers may be selected by programming the SR[0] and SR[1] inputs as follows:

SR[1]	SR[0]	Register
0	0	Register 1
0	1	Register 2
1	0	Register 3
1	1	Register 4

The 4 Tariff registers and Total register may be sequentially displayed by activating the Push Button (PB). The minimum push button make time is 5ms. The contents of the register selected for display is retained on the display for a period of 10 seconds, provided that the push button is not activated during this period. After the 10 seconds has elapsed, the display defaults to the "active" register defined by the status of the SR[0] and SR[1] inputs.

The register selected for display via the push button ($\overline{\text{PB}}$) is indicated by the relevant annunciators.

6. Optical Interface

The SA9109B device contains an interface for automatic meter reading, according to the IEC1107 Mode D standard. The IEC1107 Mode D is a single baud rate of 2400. For the optical interface protocol, the 4-bit words are converted to 8-bit words (ASCII-format).

After initiation of a serial transmission by pulling $\overline{\text{PB}}$ (pin 34) low, the data format transmitted on SDO is given below:

Code	Description
/	Start transmission
XXX	ID
3	Baud rate identification
YYYYYYYY	ID
<cr><lf><cr><lf>	Data header
0(nnnnnnnn)	Data of Reg. 1 (sign, $10e^5$, $10e^4$... $10e^0$, $10e^{-1}$)
1(nnnnnnnn)	Data of Reg. 2
2(nnnnnnnn)	Data of Reg. 3
3(nnnnnnnn)	Data of Reg. 4
4(nnnnnnnn)	Data of Reg. 'Total' = Sum of registers 0 to 3
!<cr><lf><cr><lf>	End transmission

7. Power Failure/Battery Backup

A battery backup facility is available on VBA. This feature is provided to ensure retention of the information stored in the registers, in case of power breaks.

The VSS supply to the analog circuitry and digital circuitry of this device has been separated. In the event of a power failure, the supply to the analog circuitry falls to 0V. The digital circuitry is switched to a power down mode, to minimise the supply current from an external battery backup. During this procedure, the following events take place:

- All inputs are disabled
- All outputs are placed in high impedance mode
- The oscillator is inhibited
- The LCD driver is disabled
- The contents of the RAM is retained by means of an external power source.

8. Electrostatic Discharge (ESD) Protection

The SA9109B integrated circuits inputs/outputs are protected against ESD.

9. Power Consumption

The power consumption rating of the SA9109B integrated circuit is less than 40mW.

TYPICAL APPLICATION

In the Application Circuit (Figure 1), the components required for a single phase power metering application are shown.

In Figure 1 a shunt resistor is used for current sensing. In the application, the circuitry requires a +2.5V, 0V, -2.5V DC supply.

The most important external components for the SA9109B integrated circuit are:

C_1 and C_2 are the outer loop capacitors for the two integrated oversampling A/D converters. The value of these capacitors is 560pF.

The actual values determine signal to noise and stability performance. The tolerances should be within $\pm 10\%$.

C_3 and C_4 are the inner loop capacitors of the A/D converters. The optimum value is 3.3nF. The actual values are uncritical. Values smaller than 0.5nF and larger than 5nF should be avoided.

R_1 , R_2 and RSH are the resistors defining the current level into the current sense input. The values should be selected for an input current of $16\mu A_{RMS}$ into the SA9109A, at maximum line current.

$$R_1 = R_2 = \frac{I_L}{16\mu A_{RMS}} * \frac{R_{SH}}{2}$$

Where I_L = Line current
RSH = Shunt resistor



R_3 , R_6 and R_4 set the current for the voltage sense input. The values should be selected so that the input current into the voltage sense input (virtual ground) is set to $14\mu A_{RMS}$. R_7 defines all on-chip bias and reference currents. With $R_7 = 24k\Omega$, optimum conditions are set. R_7 may be varied within $\pm 10\%$ for calibration purposes. Any change to R_7 will affect the energy calculation quadratically.

XTAL is a colour burst TV crystal ($f = 3.5795MHz$) for the oscillator. The oscillator frequency is divided down to 1.7897MHz on-chip to supply the digital circuitry and the A/D converters.

Figure 1: Application Circuit using a Shunt Resistor for Current Sensing.

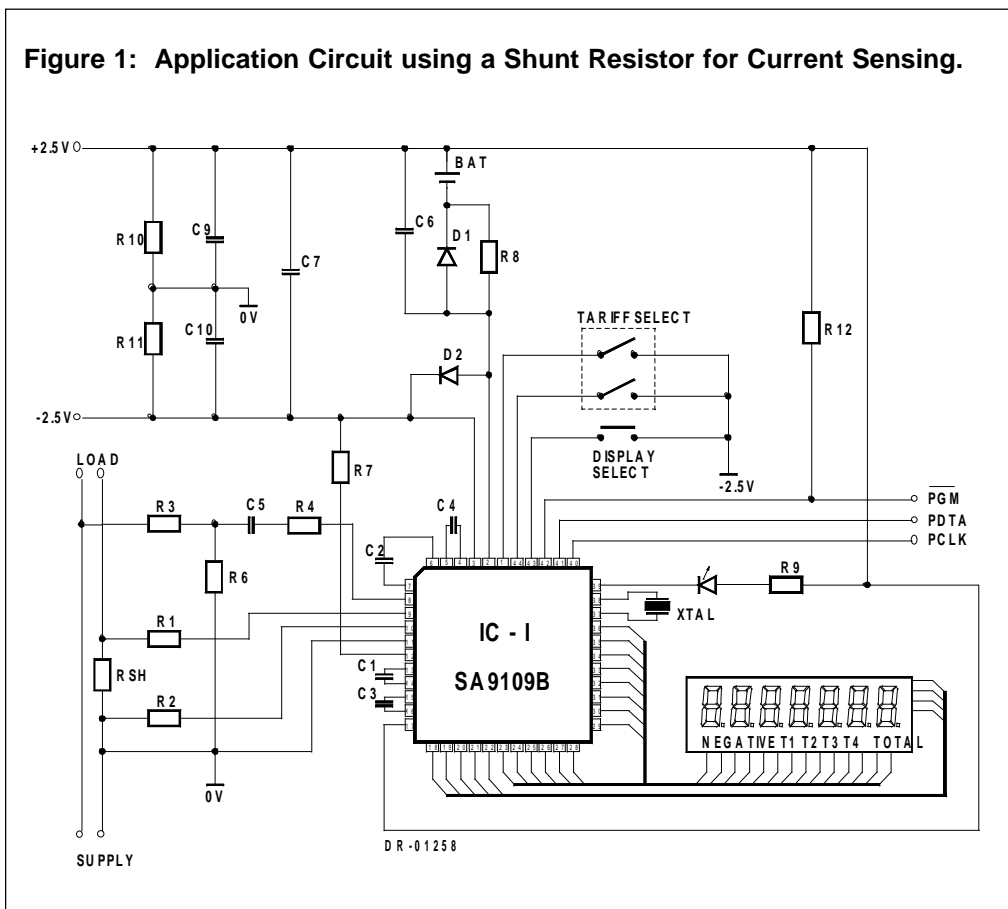

SA9109B

Parts List for Application Circuit: Figure 1

Item	Symbol	Description	Detail
1	IC-1	SA9109B	PLCC-44
2	XTAL	Crystal 3.5795 MHz	Colour burst TV
3	R1	Resistor, 1% metal	Note 1
4	R2	Resistor, 1% metal	Note 1
5	R3	Resistor, 390k, 1%, metal	Note 2
6	R4	Resistor, 1M, 1%, metal	Note 2
7	R6	Resistor, 24k, 1%, metal	Note 2
8	R7	Resistor, 24k, 1% metal	
9	R8	Resistor, 2M, 1%, metal	
10	R9	Resistor, 820 Ω , 1%, metal	
11	R10	Resistor, 830 Ω , 1%, metal	
12	R11	Resistor, 820 Ω , 1%, metal	
13	R12	Resistor, 470 Ω	
14	RSH	Shunt resistor	Note 3
15	C1	Capacitor, 560pF	
16	C2	Capacitor, 560pF	
17	C3	Capacitor, 3.3nF	
18	C4	Capacitor, 3.3nF	
19	C5	Capacitor, 1 μ F	
20	C6	Capacitor, 100nF	
21	C7	Capacitor, 820nF	Note 4
22	C9	Capacitor, 100nF	
23	C10	Capacitor, 100nF	
24	BAT	Battery (1.2V)	
25	LED	Light emitting diode	
26	D1	Diode, Shottkey	
27	D2	Diode, 1N4148	
28	PB	Push button	
29	DIPSW	DIP switch, 2 poles	

Note 1: Resistor (R1 and R2) values are dependant upon the selected value of RSH.

Note 2: Resistor (R3, R4 and R6) values are dependant upon the rated mains voltage (230V in this case).

Note 3: See TYPICAL APPLICATIONS when selecting the value of RSH.

Note 4: Capacitor (C7) to be positioned as close as possible to V_{DD} & V_{SS} of IC-1.



ORDERING INFORMATION

Part Number	Package
SA9109BFA	PLCC-44



SA9109B

Disclaimer: The information contained in this document is confidential and proprietary to South African Micro-Electronic Systems (Pty) Ltd ("SAMES") and may not be copied or disclosed to a third party, in whole or in part, without the express written consent of SAMES. The information contained herein is current as of the date of publication; however, delivery of this document shall not under any circumstances create any implication that the information contained herein is correct as of any time subsequent to such date. SAMES does not undertake to inform any recipient of this document of any changes in the information contained herein, and SAMES expressly reserves the right to make changes in such information, without notification, even if such changes would render information contained herein inaccurate or incomplete. SAMES makes no representation or warranty that any circuit designed by reference to the information contained herein, will function without errors and as intended by the designer.

Any sales or technical questions may be posted to our e-mail address below:
energy@sames.co.za

For the latest updates on datasheets, please visit our web site:
<http://www.sames.co.za>

South African Micro-Electronic Systems (Pty) Ltd

P O Box 15888,	33 Eland Street,
Lynn East,	Koedoespoort Industrial Area,
0039	Pretoria,
Republic of South Africa,	Republic of South Africa

Tel: 012 333-6021
Fax: 012 333-8071

Tel: Int +27 12 333-6021
Fax: Int +27 12 333-8071