

ELECTRICAL SPECIFICATIONS:

1.0 INDUCTANCE: (P3-J3) : (P4-J4) : (P7-J7) : 65 uH TYP @.05V, 10KHz

2.0 DC RESISTANCE: P8-J8 = P7-J7 : .5 OHM MAX
 P6-J6 = P3-J3 : .5 OHM MAX
 P5-J5 = P4-J4 : .5 OHM MAX

3.0 COMMON MODE ATTENUATION:

FREQUENCY (MHz)	CMA (-dB) TYPICAL	CMA (-dB) MIN
1	8	5
5	17	15
20	23	15
70	25	20
200	22	17
500	11	6



Bel Stewart Connector
 11118 Susquehanna Trail, South
 Glen Rock, Pa 17327-9199
 717.234.7512

MagJack®
<http://www.stewartconnector.com>

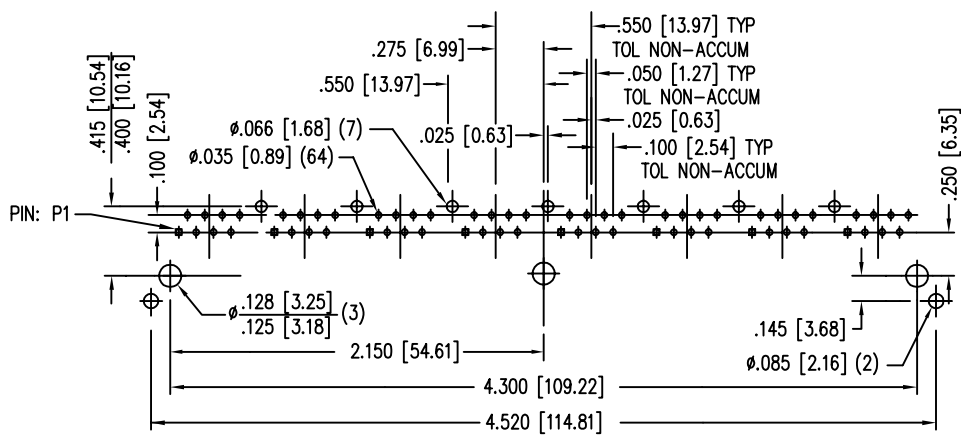
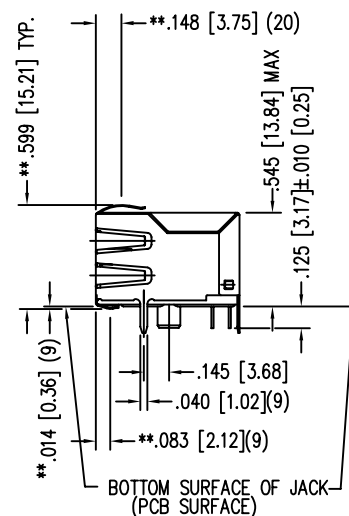
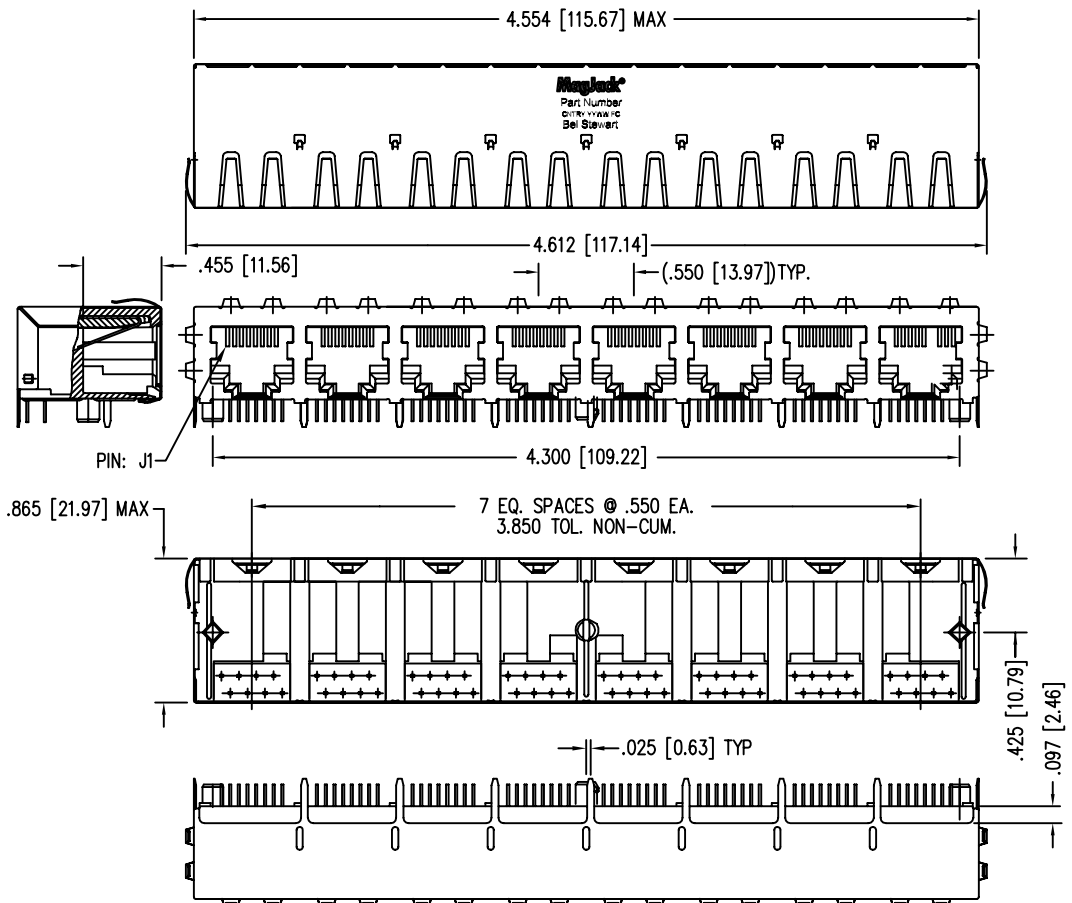

P.C.B. RECOMMENDED HOLE LAYOUT
 SEEN FROM COMPONENT SIDE
 TOLERANCE ±.003 [0.08] UNLESS OTHERWISE SPECIFIED

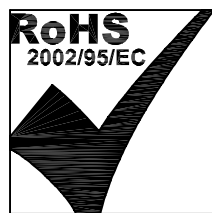

NOTES:

- CONNECTOR MATERIALS:
 HOUSING: THERMOPLASTIC UL94 V-0
 CONTACT/SHIELD: COPPER ALLOY
 SHIELD PLATING: NICKEL OR TIN
 CONTACT PLATING: SELECTIVE GOLD,
 50 MICRO-INCHES MIN. IN CONTACT AREA.
- PIN NOT ELECTRICALLY CONNECTED MAYBE OMITTED.
 SEE ELECTRICAL DRAWING FOR OMITTED PINS.
- TOLERANCES COMPLY WITH F.C.C. DIMENSION REQUIREMENTS.
- ALL TOLERANCES NOT OTHERWISE SPECIFIED TO BE ±.005 [0.13]
- WAVE SOLDER COMPATIBLE - PREHEAT 125°C/90SECS.

Bel Stewart Connector
 11118 Susquehanna Trail, South
 Glen Rock, Pa 17327-9199
 717.234.7512



<http://www.stewartconnector.com>

THIS DRAWING AND THE SUBJECT MATTER SHOWN THEREON ARE CONFIDENTIAL AND PROPERTY OF BEL STEWART CONNECTOR AND SHALL NOT BE REPRODUCED, COPIED, OR USED IN ANY MANNER WITHOUT PRIOR WRITTEN CONTENT OF BEL STEWART CONNECTOR. THE SUBJECT MATTER MAY BE PATENTED OR A PATENT MAY BE PENDING.

SHEET
2 OF 3

DRAWING NO.
SI-60088-F

REV.
05

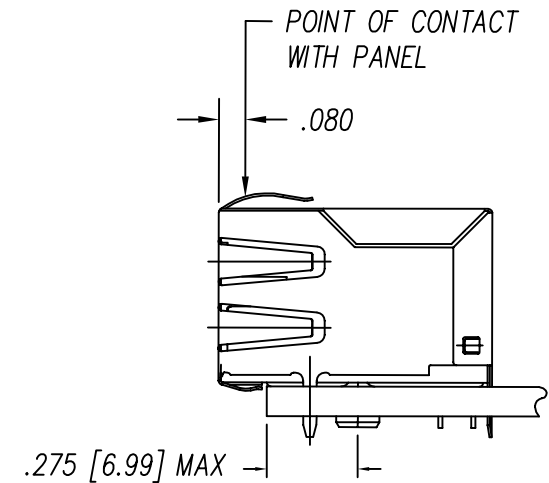
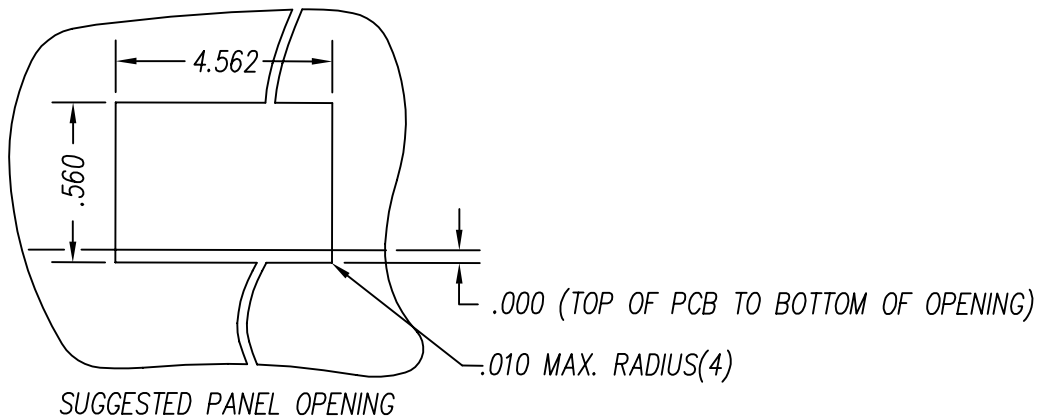

1. THE SUGGESTED PANEL OPENING IS INTENDED TO GIVE THE USER THE ABILITY TO HAVE REASONABLE JACK / PANEL CLEARANCES YET MAINTAIN RELIABLE GROUNDING CAPABILITY.
2. ALL TOLERANCES NOT OTHERWISE SPECIFIED TO BE ± 0.005 [0.13]

Bel Stewart Connector
 11118 Susquehanna Trail, South
 Glen Rock, Pa 17327-9199
 717.234.7512

MagJack®

<http://www.stewartconnector.com>

THIS DRAWING AND THE SUBJECT MATTER SHOWN THEREON ARE CONFIDENTIAL AND PROPERTY OF BEL STEWART CONNECTOR AND SHALL NOT BE REPRODUCED, COPIED, OR USED IN ANY MANNER WITHOUT PRIOR WRITTEN CONTENT OF BEL STEWART CONNECTOR. THE SUBJECT MATTER MAY BE PATENTED OR A PATENT MAY BE PENDING.

SHEET
3 OF 3

DRAWING NO.
SI-60088-F

REV.
05