

### ■ FEATURES

- Wide Vcc operation voltage : 2.4V~5.5V
- Very low power consumption :
  - Vcc = 3.0V C-grade : 22mA (@55ns) operating current  
I-grade : 23mA (@55ns) operating current  
C-grade : 17mA (@70ns) operating current  
I-grade : 18mA (@70ns) operating current  
0.3uA (Typ.) CMOS standby current
  - Vcc = 5.0V C-grade : 53mA (@55ns) operating current  
I-grade : 55mA (@55ns) operating current  
C-grade : 43mA (@70ns) operating current  
I-grade : 45mA (@70ns) operating current  
1.0uA (Typ.) CMOS standby current
- High speed access time :
  - 55 55ns
  - 70 70ns
- Automatic power down when chip is deselected
- Three state outputs and TTL compatible

- Fully static operation
- Data retention supply voltage as low as 1.5V
- Easy expansion with CE2, CE1, and OE options

### ■ DESCRIPTION

The STC62WV2568 is a high performance, very low power CMOS Static Random Access Memory organized as 262,144 words by 8 bits and operates from a wide range of 2.4V to 5.5V supply voltage. Advanced CMOS technology and circuit techniques provide both high speed and low power features with a typical CMOS standby current of 0.3uA at 3.0V/25°C and maximum access time of 55ns at 3.0V/85°C. Easy memory expansion is provided by an active LOW chip enable (CE1), an active HIGH chip enable (CE2), and active LOW output enable (OE) and three-state output drivers. The STC62WV2568 has an automatic power down feature, reducing the power consumption significantly when chip is deselected. The STC62WV2568 is available in DICE form, JEDEC standard 32 pin 450mil Plastic SOP, 8mmx13.4mm STSOP and 8mmx20mm TSOP.

### ■ PRODUCT FAMILY

PRODUCT FAMILY	OPERATING TEMPERATURE	Vcc RANGE	SPEED ( ns )	POWER DISSIPATION				PKG TYPE
				STANDBY (IccSB1, Max)		Operating (Icc, Max)		
				Vcc=3.0V	Vcc=5.0V	Vcc=3.0V	Vcc=5.0V	
STC62WV2568DC	+0 °C to +70 °C	2.4V ~5.5V	55ns :3.0~5.5V 70ns :2.7~5.5V	3.0uA	10uA	17mA	43mA	DICE
STC62WV2568TC			TSOP-32					
STC62WV2568STC			STSOP-32					
STC62WV2568SC			SOP-32					
STC62WV2568DI	-40 °C to +85 °C	2.4V ~ 5.5V	55/70	5.0uA	30uA	18mA	45mA	DICE
STC62WV2568TI								TSOP-32
STC62WV2568STI								STSOP-32
STC62WV2568SI								SOP-32

### ■ PIN CONFIGURATIONS

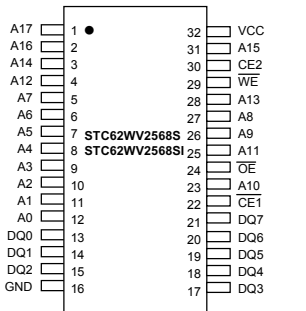
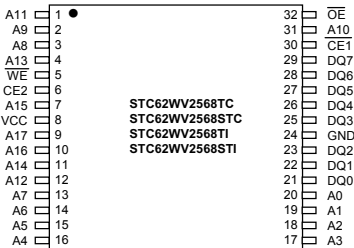

### ■ BLOCK DIAGRAM

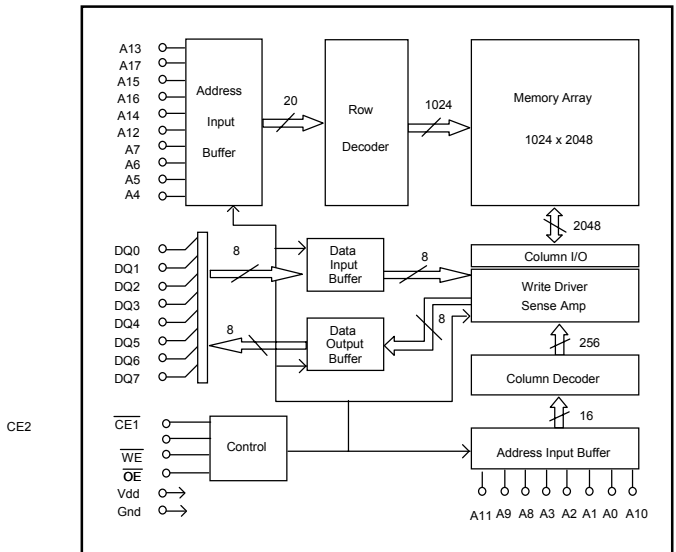

STC International Limited. reserves the right to modify document contents without notice.

## ■ PIN DESCRIPTIONS

Name	Function
<b>A0-A17 Address Input</b>	These 18 address inputs select one of the 262,144 x 8-bit words in the RAM
<b><math>\overline{CE1}</math> Chip Enable 1 Input CE2 Chip Enable 2 Input</b>	$\overline{CE1}$ is active LOW and CE2 is active HIGH. Both chip enables must be active when data read from or write to the device. If either chip enable is not active, the device is deselected and is in a standby power mode. The DQ pins will be in the high impedance state when the device is deselected.
<b><math>\overline{WE}</math> Write Enable Input</b>	The write enable input is active LOW and controls read and write operations. With the chip selected, when $\overline{WE}$ is HIGH and $\overline{OE}$ is LOW, output data will be present on the DQ pins; when $\overline{WE}$ is LOW, the data present on the DQ pins will be written into the selected memory location.
<b><math>\overline{OE}</math> Output Enable Input</b>	The output enable input is active LOW. If the output enable is active while the chip is selected and the write enable is inactive, data will be present on the DQ pins and they will be enabled. The DQ pins will be in the high impedance state when $\overline{OE}$ is inactive.
<b>DQ0-DQ7 Data Input/Output Ports</b>	These 8 bi-directional ports are used to read data from or write data into the RAM.
<b>Vcc</b>	Power Supply
<b>Gnd</b>	Ground

## ■ TRUTH TABLE

MODE	$\overline{WE}$	$\overline{CE1}$	CE2	$\overline{OE}$	I/O OPERATION	Vcc CURRENT
Not selected (Power Down)	X	H	X	X	High Z	$I_{CCSB}, I_{CCSB1}$
	X	X	L	X		
Output Disabled	H	L	H	H	High Z	$I_{CC}$
Read	H	L	H	L	DOUT	$I_{CC}$
Write	L	L	H	X	DIN	$I_{CC}$

## ■ ABSOLUTE MAXIMUM RATINGS<sup>(1)</sup>

SYMBOL	PARAMETER	RATING	UNITS
V <sub>TERM</sub>	Terminal Voltage with Respect to GND	-0.5 to V <sub>cc</sub> +0.5	V
T <sub>BIAS</sub>	Temperature Under Bias	-40 to +85	°C
T <sub>STG</sub>	Storage Temperature	-60 to +150	°C
P <sub>T</sub>	Power Dissipation	1.0	W
I <sub>OUT</sub>	DC Output Current	20	mA

1. Stresses greater than those listed under ABSOLUTE MAXIMUM RATINGS may cause permanent damage to the device. This is a stress rating only and functional operation of the device at these or any other conditions above those indicated in the operational sections of this specification is not implied. Exposure to absolute maximum rating conditions for extended periods may affect reliability.

## ■ OPERATING RANGE

RANGE	AMBIENT TEMPERATURE	Vcc
Commercial	0 °C to +70 °C	2.4V ~ 5.5V
Industrial	-40 °C to +85 °C	2.4V ~ 5.5V

## ■ CAPACITANCE <sup>(1)</sup> (TA = 25°C, f = 1.0 MHz)

SYMBOL	PARAMETER	CONDITIONS	MAX.	UNIT
C <sub>IN</sub>	Input Capacitance	V <sub>IN</sub> =0V	6	pF
C <sub>DQ</sub>	Input/Output Capacitance	V <sub>I/O</sub> =0V	8	pF

1. This parameter is guaranteed and not 100% tested.

## ■ DC ELECTRICAL CHARACTERISTICS ( TA = -40°C to + 85°C )

PARAMETER NAME	PARAMETER	TEST CONDITIONS	MIN.	TYP. (1)	MAX.	UNITS	
V <sub>IL</sub>	Guaranteed Input Low Voltage <sup>(3)</sup>		V <sub>CC</sub> =3.0V	-0.5	--	0.8	V
			V <sub>CC</sub> =5.0V				
V <sub>IH</sub>	Guaranteed Input High Voltage <sup>(3)</sup>		V <sub>CC</sub> =3.0V	2.0	--	V <sub>CC</sub> +0.3	V
			V <sub>CC</sub> =5.0V	2.2	--		
I <sub>IL</sub>	Input Leakage Current	V <sub>CC</sub> = Max, V <sub>IN</sub> = 0V to V <sub>CC</sub>	--	--	1	uA	
I <sub>LO</sub>	Output Leakage Current	V <sub>CC</sub> = Max, $\overline{CE1} = V_{IH}$ or CE2=V <sub>IL</sub> or $\overline{OE} = V_{IH}$ , V <sub>IO</sub> = 0V to V <sub>CC</sub>	--	--	1	uA	
V <sub>OL</sub>	Output Low Voltage	V <sub>CC</sub> = Max, I <sub>OL</sub> = 2.0mA	V <sub>CC</sub> =3.0V	--	--	0.4	V
			V <sub>CC</sub> =5.0V				
V <sub>OH</sub>	Output High Voltage	V <sub>CC</sub> = Min, I <sub>OH</sub> = -1.0mA	V <sub>CC</sub> =3.0V	2.4	--	--	V
			V <sub>CC</sub> =5.0V				
I <sub>CC</sub> <sup>(5)</sup>	Operating Power Supply Current	V <sub>CC</sub> =Max, $\overline{CE1}=V_{IL}$ , CE2=V <sub>IH</sub> I <sub>DQ</sub> = 0mA, F = Fmax <sup>(2)</sup>	70ns V <sub>CC</sub> =3.0V	--	--	18	mA
			70ns V <sub>CC</sub> =5.0V	--	--	45	
I <sub>CCSB</sub>	Standby Current-TTL	V <sub>CC</sub> = Max, $\overline{CE1} = V_{IH}$ or CE2=V <sub>IL</sub> I <sub>DQ</sub> = 0mA	V <sub>CC</sub> =3.0V	--	--	0.5	mA
			V <sub>CC</sub> =5.0V	--	--	1.0	
I <sub>CCSB1</sub> <sup>(4)</sup>	Standby Current-CMOS	V <sub>CC</sub> = Max, $\overline{CE1} \geq V_{CC}-0.2V$ or CE2 $\leq 0.2V$ ; V <sub>IN</sub> $\geq V_{CC} - 0.2V$ or V <sub>IN</sub> $\leq 0.2V$	V <sub>CC</sub> =3.0V	--	0.3	5	uA
			V <sub>CC</sub> =5.0V	--	1.0	30	

1. Typical characteristics are at TA = 25°C.

2. Fmax = 1/t<sub>RC</sub>.

3. These are absolute values with respect to device ground and all overshoots due to system or tester noise are included.

4. I<sub>CCSB1\_MAX</sub> is 3uA/10uA at V<sub>CC</sub>=3V/5V and TA=70°C.

5. I<sub>CC\_MAX</sub> is 23mA(@3V)/55mA(@5V) under 55ns operation.

## ■ DATA RETENTION CHARACTERISTICS ( TA = -40°C to + 85°C )

SYMBOL	PARAMETER	TEST CONDITIONS	MIN.	TYP. (1)	MAX.	UNITS
V <sub>DR</sub>	V <sub>CC</sub> for Data Retention	$\overline{CE1} \geq V_{CC} - 0.2V$ or CE2 $\leq 0.2V$ , V <sub>IN</sub> $\geq V_{CC} - 0.2V$ or V <sub>IN</sub> $\leq 0.2V$	1.5	--	--	V
I <sub>CCDR</sub> <sup>(3)</sup>	Data Retention Current	$\overline{CE1} \geq V_{CC} - 0.2V$ or CE2 $\leq 0.2V$ , V <sub>IN</sub> $\geq V_{CC} - 0.2V$ or V <sub>IN</sub> $\leq 0.2V$	--	0.1	1.0	uA
t <sub>CDR</sub>	Chip Deselect to Data Retention Time	See Retention Waveform	0	--	--	ns
t <sub>R</sub>	Operation Recovery Time		T <sub>RC</sub> <sup>(2)</sup>	--	--	ns

1. V<sub>CC</sub> = 1.5V, T<sub>A</sub> = + 25°C

2. t<sub>RC</sub> = Read Cycle Time

3. I<sub>CCDR\_MAX</sub> is 0.7uA at TA=70°C.

### ■ LOW V<sub>CC</sub> DATA RETENTION WAVEFORM (1) ( $\overline{CE1}$ Controlled )

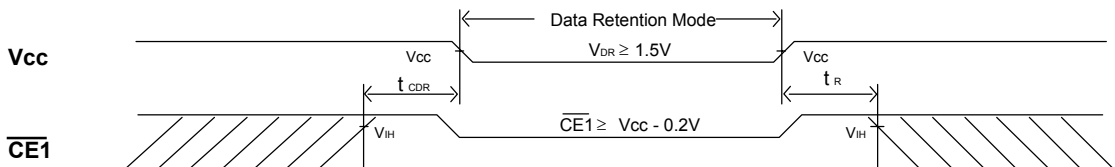

### ■ LOW V<sub>CC</sub> DATA RETENTION WAVEFORM (2) ( CE2 Controlled )

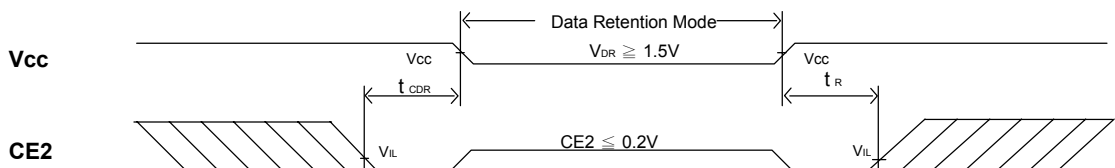

## ■ AC TEST CONDITIONS

(Test Load and Input/Output Reference)

Input Pulse Levels	V <sub>cc</sub> / 0V
Input Rise and Fall Times	1V/ns
Input and Output Timing Reference Level	0.5V <sub>cc</sub>
Output Load	C <sub>L</sub> = 100pF+1TTL C <sub>L</sub> = 30pF+1TTL

## ■ KEY TO SWITCHING WAVEFORMS

WAVEFORM	INPUTS	OUTPUTS
	MUST BE STEADY	MUST BE STEADY
	MAY CHANGE FROM H TO L	WILL BE CHANGE FROM H TO L
	MAY CHANGE FROM L TO H	WILL BE CHANGE FROM L TO H
	DON'T CARE: ANY CHANGE PERMITTED	CHANGE : STATE UNKNOWN
	DOES NOT APPLY	CENTER LINE IS HIGH IMPEDANCE "OFF" STATE

## ■ AC ELECTRICAL CHARACTERISTICS (TA = -40°C to + 85°C) READ CYCLE

JEDEC PARAMETER NAME	PARAMETER NAME	DESCRIPTION	CYCLE TIME : 55ns (V <sub>cc</sub> = 3.0~5.5V)			CYCLE TIME : 70ns (V <sub>cc</sub> = 2.7~5.5V)			UNIT
			MIN.	TYP.	MAX.	MIN.	TYP.	MAX.	
t <sub>AVAX</sub>	t <sub>RC</sub>	Read Cycle Time	55	--	--	70	--	--	ns
t <sub>AVQV</sub>	t <sub>AA</sub>	Address Access Time	--	--	55	--	--	70	ns
t <sub>E1LQV</sub>	t <sub>ACS1</sub>	Chip Select Access Time (CE1)	--	--	55	--	--	70	ns
t <sub>E2HOV</sub>	t <sub>ACS2</sub>	Chip Select Access Time (CE2)	--	--	55	--	--	70	ns
t <sub>GLQV</sub>	t <sub>OE</sub>	Output Enable to Output Valid	--	--	30	--	--	35	ns
t <sub>E1LQX</sub>	t <sub>CLZ1</sub>	Chip Select to Output Low Z (CE1)	10	--	--	10	--	--	ns
t <sub>E2HOX</sub>	t <sub>CLZ2</sub>	Chip Select to Output Low Z (CE2)	10	--	--	10	--	--	ns
t <sub>GLQX</sub>	t <sub>OLZ</sub>	Output Enable to Output in Low Z	5	--	--	5	--	--	ns
t <sub>E1HQZ</sub>	t <sub>CHZ1</sub>	Chip Deselect to Output in High Z (CE1)	--	--	30	--	--	35	ns
t <sub>E2HQZ</sub>	t <sub>CHZ2</sub>	Chip Deselect to Output in High Z (CE2)	--	--	30	--	--	35	ns
t <sub>GHQZ</sub>	t <sub>OHZ</sub>	Output Disable to Output in High Z	--	--	25	--	--	30	ns
t <sub>AXOX</sub>	t <sub>OH</sub>	Data Hold from Address Change	10	--	--	10	--	--	ns

## SWITCHING WAVEFORMS (READ CYCLE)

### READ CYCLE1 (1,2,4)

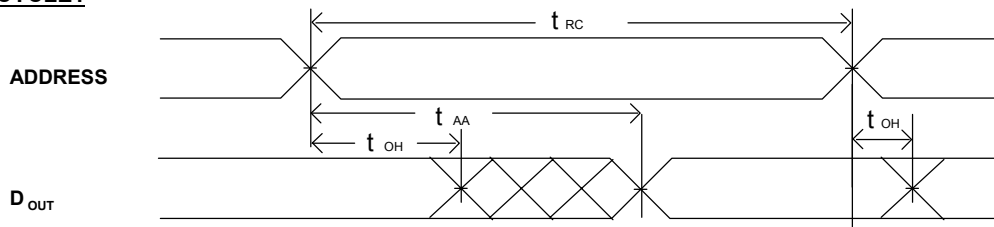

### READ CYCLE2 (1,3,4)

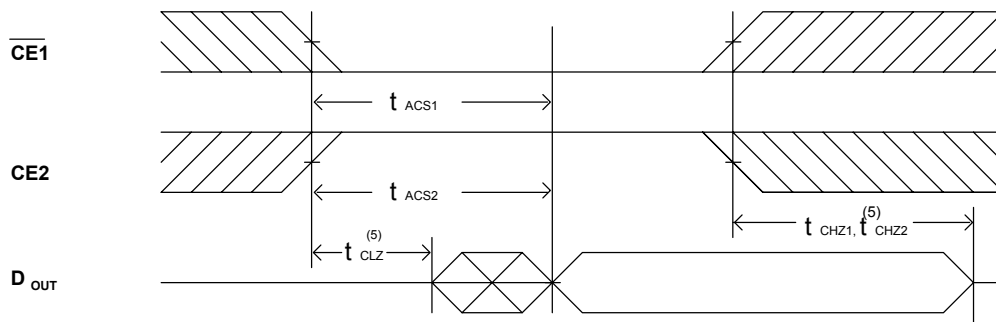

### READ CYCLE3 (1,4)

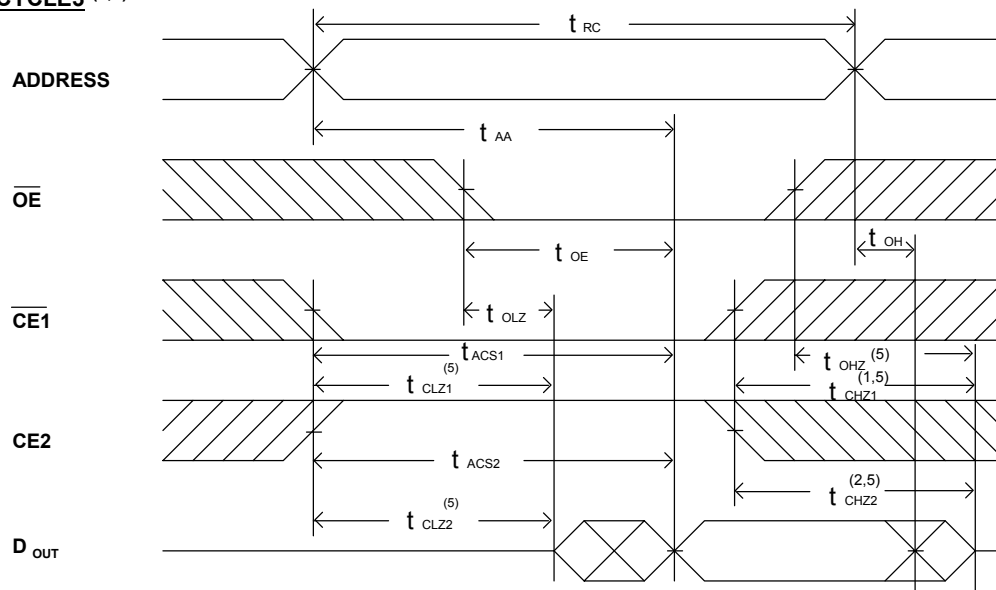

#### NOTES:

1. WE is high in read Cycle.
2. Device is continuously selected when  $\overline{CE1} = V_{IL}$  and  $CE2 = V_{IH}$ .
3. Address valid prior to or coincident with  $\overline{CE1}$  transition low and/or  $CE2$  transition high.
4.  $\overline{OE} = V_{IL}$ .
5. The parameter is guaranteed but not 100% tested.

## ■ AC ELECTRICAL CHARACTERISTICS (TA = -40°C to +85°C)

### WRITE CYCLE

JEDEC PARAMETER NAME	PARAMETER NAME	DESCRIPTION	CYCLE TIME : 55ns (Vcc = 3.0-5.5V)			CYCLE TIME : 70ns (Vcc = 2.7-5.5V)			UNIT
			MIN.	TYP.	MAX.	MIN.	TYP.	MAX.	
$t_{AVAX}$	$t_{WC}$	Write Cycle Time	55	--	--	70	--	--	ns
$t_{E1LWH}$	$t_{CW}$	Chip Select to End of Write	55	--	--	70	--	--	ns
$t_{AVWL}$	$t_{AS}$	Address Setup Time	0	--	--	0	--	--	ns
$t_{AVWH}$	$t_{AW}$	Address Valid to End of Write	55	--	--	70	--	--	ns
$t_{WLWH}$	$t_{WP}$	Write Pulse Width	30	--	--	35	--	--	ns
$t_{WHAX}$	$t_{WR1}$	Write recovery Time ( $\overline{CE1}, \overline{WE}$ )	0	--	--	0	--	--	ns
$t_{E2LAX}$	$t_{WR2}$	Write recovery Time (CE2)	0	--	--	0	--	--	ns
$t_{WLQZ}$	$t_{WHZ}$	Write to Output in High Z	--	--	25	--	--	30	ns
$t_{DVWH}$	$t_{DW}$	Data to Write Time Overlap	25	--	--	30	--	--	ns
$t_{WHDX}$	$t_{DH}$	Data Hold from Write Time	0	--	--	0	--	--	ns
$t_{GHQZ}$	$t_{OHZ}$	Output Disable to Output in High Z	--	--	25	--	--	30	ns
$t_{WHOX}$	$t_{OW}$	End of Write to Output Active	5	--	--	5	--	--	ns

## ■ SWITCHING WAVEFORMS (WRITE CYCLE)

### WRITE CYCLE1<sup>(1)</sup>

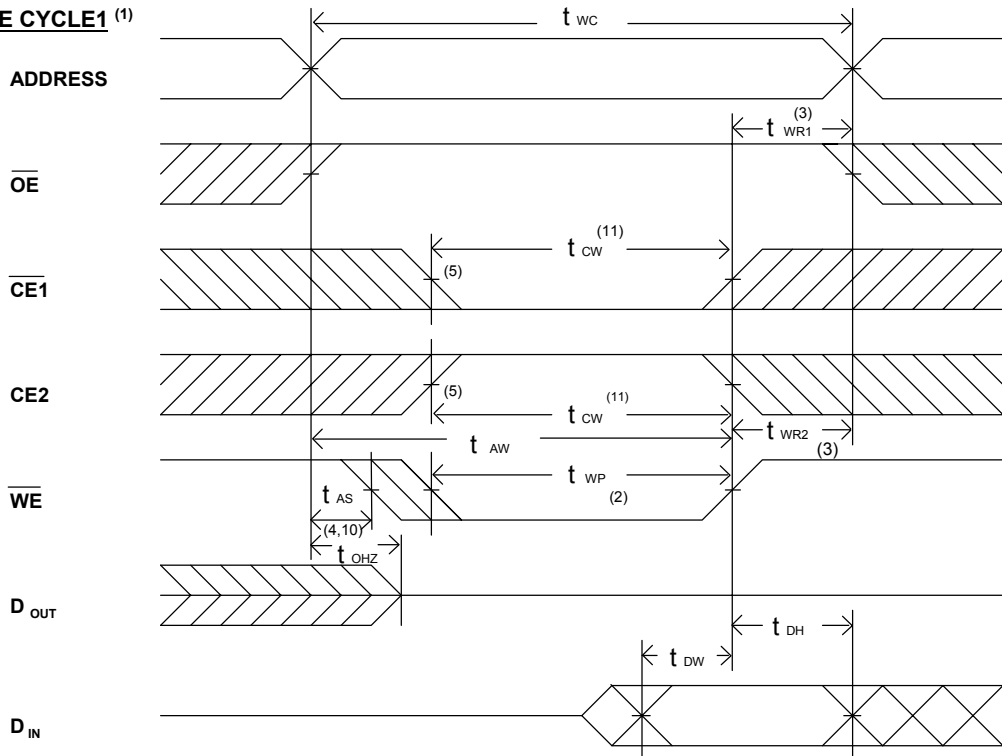

## WRITE CYCLE<sup>2</sup> (1,6)

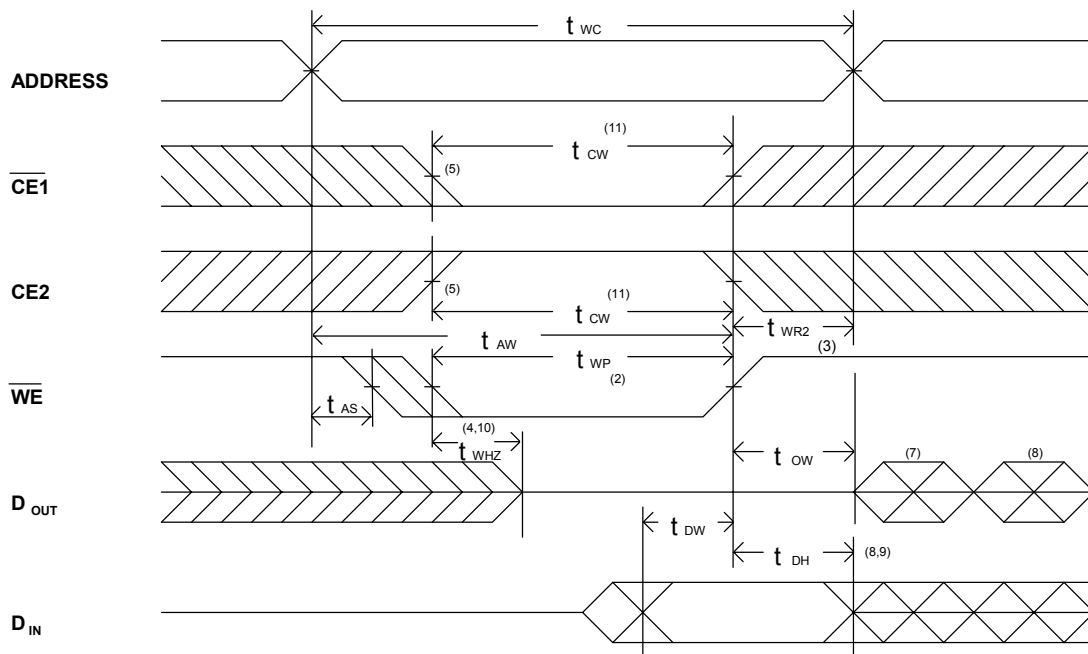

### NOTES:

1.  $\overline{WE}$  must be high during address transitions.
2. The internal write time of the memory is defined by the overlap of  $\overline{CE1}$  and  $\overline{CE2}$  active and  $\overline{WE}$  low. All signals must be active to initiate a write and any one signal can terminate a write by going inactive. The data input setup and hold timing should be referenced to the second transition edge of the signal that terminates the write.
3.  $t_{WR}$  is measured from the earlier of  $\overline{CE1}$  or  $\overline{WE}$  going high or  $\overline{CE2}$  going low at the end of write cycle.
4. During this period, DQ pins are in the output state so that the input signals of opposite phase to the outputs must not be applied.
5. If the  $\overline{CE1}$  low transition or the  $\overline{CE2}$  high transition occurs simultaneously with the  $\overline{WE}$  low transitions or after the  $\overline{WE}$  transition, output remain in a high impedance state.
6.  $\overline{OE}$  is continuously low ( $\overline{OE} = V_{IL}$ ).
7.  $D_{OUT}$  is the same phase of write data of this write cycle.
8.  $D_{OUT}$  is the read data of next address.
9. If  $\overline{CE1}$  is low and  $\overline{CE2}$  is high during this period, DQ pins are in the output state. Then the data input signals of opposite phase to the outputs must not be applied to them.
10. The parameter is guaranteed but not 100% tested.
11.  $t_{CW}$  is measured from the later of  $\overline{CE1}$  going low or  $\overline{CE2}$  going high to the end of write.

## ORDERING INFORMATION

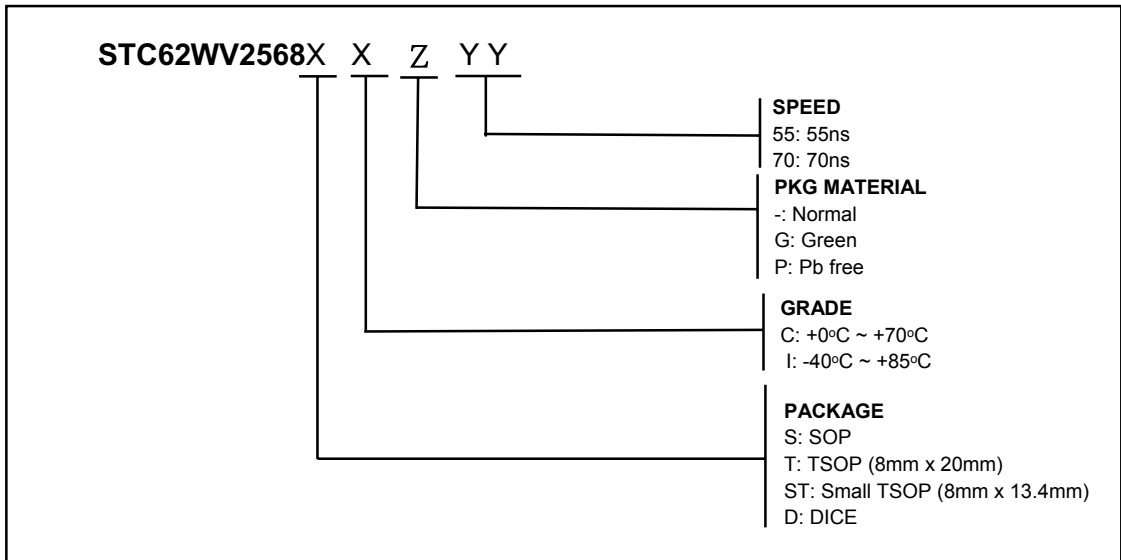

Note:  
STC (STC International Limited.) assumes no responsibility for the application or use of any product or circuit described herein. STC does not authorize its products for use as critical components in any application in which the failure of the STC product may be expected to result in significant injury or death, including life-support systems and critical medical instruments.

## PACKAGE DIMENSIONS

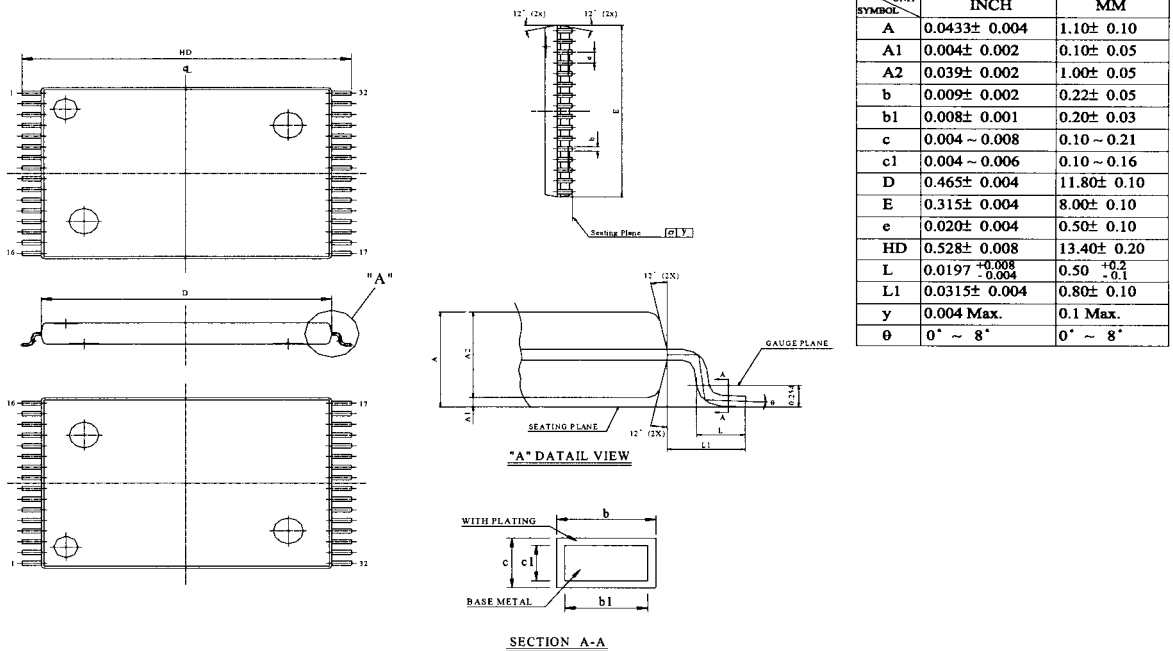

**STSOP - 32**



## ■ PACKAGE DIMENSIONS (continued)

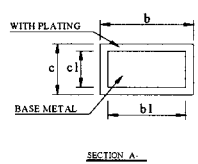
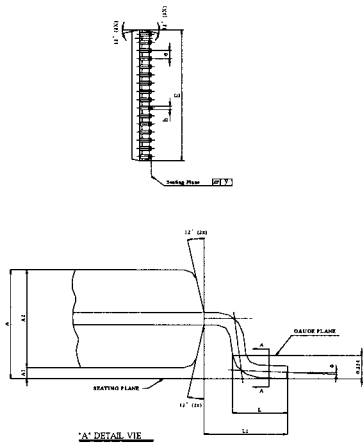
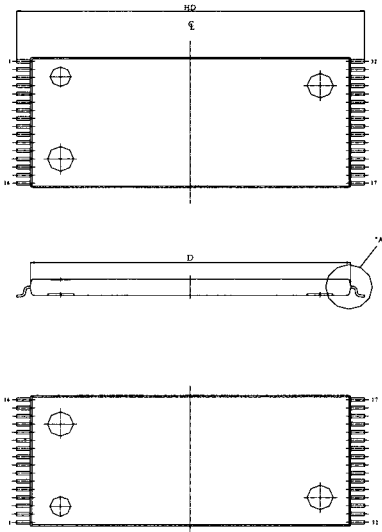

UNIT SYMBOL	INCH	MM
A	0.0433± 0.004	1.10± 0.10
A1	0.004± 0.002	0.10± 0.05
A2	0.039± 0.002	1.00± 0.05
b	0.009± 0.002	0.22± 0.05
b1	0.008± 0.001	0.20± 0.03
c	0.004 ~ 0.008	0.10 ~ 0.21
c1	0.004 ~ 0.006	0.10 ~ 0.16
D	0.724± 0.004	18.40± 0.10
E	0.315± 0.004	8.00± 0.10
e	0.020± 0.004	0.50± 0.10
HD	0.787± 0.008	20.00± 0.20
L	0.0197 <sup>+0.008</sup> <sub>-0.004</sub>	0.50 <sup>+0.2</sup> <sub>-0.1</sub>
L1	0.0315± 0.004	0.80± 0.10
y	0.004 Max.	0.1 Max.
θ	0° ~ 8°	0° ~ 8°

TSOP - 32

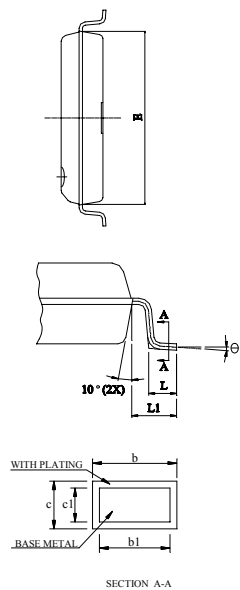
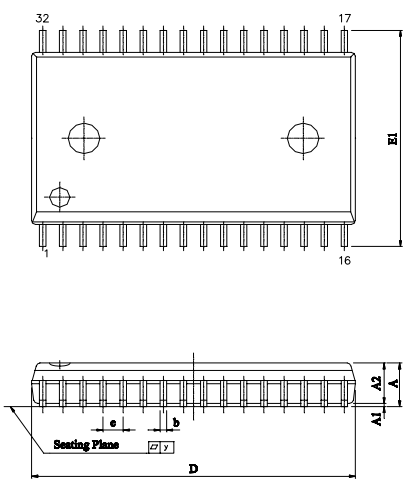

UNIT SYMBOL	INCH	MM
A	0.111±0.007	2.821±0.176
A1	0.009±0.005	0.229±0.127
A2	0.1055±0.0055	2.680±0.140
b	0.014 ~ 0.020	0.35 ~ 0.50
b1	0.014 ~ 0.018	0.35 ~ 0.46
c	0.006 ~ 0.012	0.15 ~ 0.32
c1	0.006 ~ 0.011	0.15 ~ 0.28
D	0.805±0.005	20.447±0.127
E	0.445±0.005	11.303±0.127
EI	0.555±0.012	14.097±0.305
e	0.050±0.006	1.270±0.152
L	0.033±0.010	0.834±0.25
L1	0.055±0.008	1.397±0.203
y	0.004 Max.	0.1 Max.
θ	0° ~ 10°	0° ~ 10°

SOP - 32