

TOSHIBA CMOS DIGITAL INTEGRATED CIRCUIT SILICON MONOLITHIC

TC7MZ157FK

Low Voltage Quad 2-Channel Multiplexer With 5V Tolerant Inputs And Outputs

The TC7MZ157 is a high performance CMOS MULTIPLEXER. Designed for use in 3.3 Volt systems, it achieves high speed operation while maintaining the CMOS low power dissipation.

The device is designed for low-voltage (3.3V) V_{CC} applications, but it could be used to interface to 5V supply environment for inputs.

It consists of four 2-input digital multiplexers with common select and strobe inputs.

When the \overline{STROBE} input is held "H" level, selection of data is inhibited and all the outputs become "L" level.

The SELECT decoding determines whether the A or B inputs get routed to their corresponding Y outputs.

All inputs are equipped with protection circuits against static discharge.

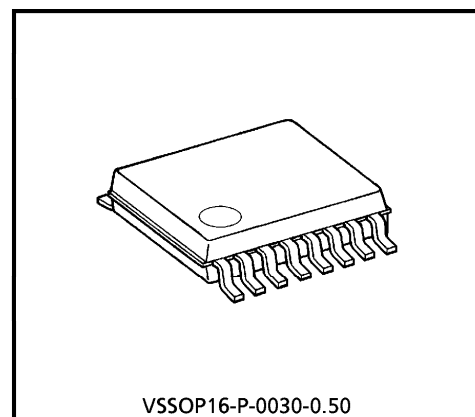

VSSOP16-P-0030-0.50

Weight: 0.02g (Typ.)

Features

- Low voltage operation: $V_{CC} = 2.0 \sim 3.6V$
- High speed operation : $t_{pd} = 6.0ns$ (max) ($V_{CC} = 3.0 \sim 3.6V$)
- Output current : $|I_{OH}| / I_{OL} = 24mA$ (min)
($V_{CC} = 3.0V$)
- Latch-up performance : $\pm 500mA$
- Available in VSSOP (US16)
- Power down protection is provided on all inputs and outputs.
- Pin and function compatible with the 74 series (74AC/VHC/HC/F/ALS/LS etc.) 157 type.

980910EBA2

● TOSHIBA is continually working to improve the quality and the reliability of its products. Nevertheless, semiconductor devices in general can malfunction or fail due to their inherent electrical sensitivity and vulnerability to physical stress. It is the responsibility of the buyer, when utilizing TOSHIBA products, to observe standards of safety, and to avoid situations in which a malfunction or failure of a TOSHIBA product could cause loss of human life, bodily injury or damage to property. In developing your designs, please ensure that TOSHIBA products are used within specified operating ranges as set forth in the most recent products specifications. Also, please keep in mind the precautions and conditions set forth in the TOSHIBA Semiconductor Reliability Handbook.

Pin Assignment

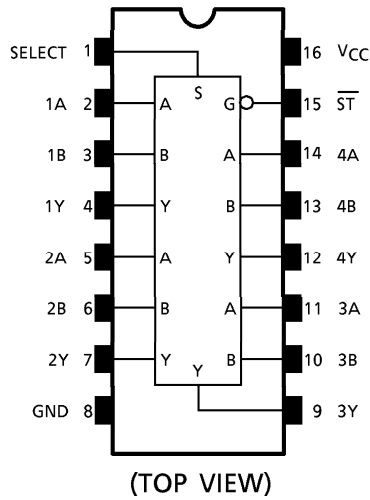

Truth Table

INPUTS				OUTPUTS
\overline{ST}	SELECT	A	B	Y
H	X	X	X	L
L	L	L	X	L
L	L	H	X	H
L	H	X	L	L
L	H	X	H	H

X: Don't Care

IEC Logic Symbol

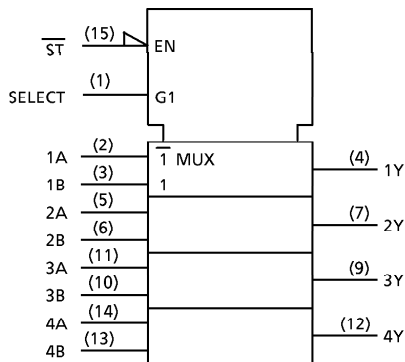

System Diagram

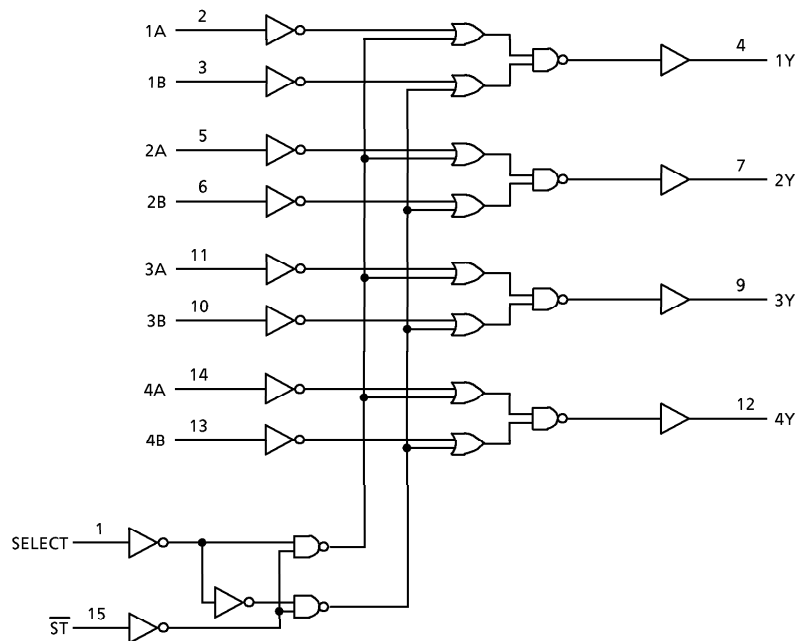

980910EBA2'

- The products described in this document are subject to the foreign exchange and foreign trade laws.
- The information contained herein is presented only as a guide for the applications of our products. No responsibility is assumed by TOSHIBA CORPORATION for any infringements of intellectual property or other rights of the third parties which may result from its use. No license is granted by implication or otherwise under any intellectual property or other rights of TOSHIBA CORPORATION or others.
- The information contained herein is subject to change without notice.

Maximum Ratings

PARAMETER	SYMBOL	RATING	UNIT
Supply Voltage Range	V_{CC}	-0.5~7.0	V
DC Input Voltage	V_{IN}	-0.5~7.0	V
DC Output Voltage	V_{OUT}	-0.5~7.0 (Note 1)	V
		-0.5~ V_{CC} +0.5 (Note 2)	
Input Diode Current	I_{IK}	-50	mA
Output Diode Current	I_{OK}	±50 (Note 3)	mA
DC Output Current	I_{OUT}	±50	mA
Power Dissipation	P_D	TBD	mW
DC V_{CC} /Ground Current	I_{CC}/I_{GND}	±100	mA
Storage Temperature	T_{stg}	-65~150	°C

(Note 1): $V_{CC}=0V$

(Note 2): High or Low State. I_{OUT} absolute maximum rating must be observed.

(Note 3): $V_{OUT}<GND$, $V_{OUT}>V_{CC}$

Recommended Operating Conditions

PARAMETER	SYMBOL	RATING	UNIT
Supply Voltage	V_{CC}	2.0~3.6	V
		1.5~3.6 (Note 4)	
Input Voltage	V_{IN}	0~5.5	V
Output Voltage	V_{OUT}	0~5.5 (Note 5)	V
		0~ V_{CC} (Note 6)	
Output Current	I_{OH}/I_{OL}	±24 (Note 7)	mA
		±12 (Note 8)	
Operating Temperature	T_{opr}	-40~85	°C
Input Rise And Fall Time	dt/dv	0~10 (Note 9)	ns/V

(Note 4): Data Retention Only

(Note 5): $V_{CC}=0V$

(Note 6): High or Low State

(Note 7): $V_{CC}=3.0\sim 3.6V$

(Note 8): $V_{CC}=2.7\sim 3.0V$

(Note 9): $V_{IN}=0.8\sim 2.0V$, $V_{CC}=3.0V$

Electrical Characteristics

DC Characteristics (Ta = -40~85°C)

PARAMETER		SYMBOL	TEST CONDITION		V _{CC} (V)	Min	Max	UNIT
Input Voltage	"H" Level	V _{IH}			2.7~3.6	2.0	—	V
	"L" Level	V _{IL}			2.7~3.6	—	0.8	
Output Voltage	"H" Level	V _{OH}	V _{IN} = V _{IH} or V _{IL}	I _{OH} = -100μA	2.7~3.6	V _{CC} - 0.2	—	V
				I _{OH} = -12mA	2.7	2.2	—	
				I _{OH} = -18mA	3.0	2.4	—	
				I _{OH} = -24mA	3.0	2.2	—	
	"L" Level	V _{OL}	V _{IN} = V _{IH} or V _{IL}	I _{OL} = 100μA	2.7~3.6	—	0.2	
				I _{OL} = 12mA	2.7	—	0.4	
				I _{OL} = 16mA	3.0	—	0.4	
				I _{OL} = 24mA	3.0	—	0.55	
Input Leakage Current		I _{IN}	V _{IN} = 0~5.5V		2.7~3.6	—	±5.0	μA
Power Off Leakage Current		I _{OFF}	V _{IN} / V _{OUT} = 5.5V		0	—	10.0	μA
Quiescent Supply Current		I _{CC}	V _{IN} = V _{CC} or GND		2.7~3.6	—	10.0	μA
			V _{IN} / V _{OUT} = 3.6~5.5V		2.7~3.6	—	±10.0	
Increase In I _{CC} Per Input		ΔI _{CC}	V _{IH} = V _{CC} - 0.6V		2.7~3.6	—	500	μA

AC Characteristics (Ta = -40~85°C)

PARAMETER		SYMBOL	TEST CONDITION		V _{CC} (V)	Min	Max	UNIT
Propagation Delay Time (A, B-Y)	t _{pLH} t _{pHL}	(Fig.1, 2)			2.7	—	6.3	ns
					3.3 ± 0.3	1.5	5.8	
Propagation Delay Time (SELECT-Y)	t _{pLH} t _{pHL}	(Fig.1, 2)			2.7	—	8.0	ns
					3.3 ± 0.3	1.5	7.0	
Propagation Delay Time (ST-Y)	t _{pLH} t _{pHL}	(Fig.1, 2)			2.7	—	8.0	ns
					3.3 ± 0.3	1.5	7.0	
Output To Output Skew	t _{osLH} t _{osHL}	(Note 10)			2.7	—	—	ns
					3.3 ± 0.3	—	1.0	

(Note 10): Parameter guaranteed by design.

$$(t_{osLH} = |t_{pLHm} - t_{pLHn}|, t_{osHL} = |t_{pHLm} - t_{pHLn}|)$$

Dynamic Switching Characteristics ($T_a = 25^\circ\text{C}$, Input $t_r = t_f = 2.5\text{ns}$, $C_L = 50\text{pF}$, $R_L = 500\Omega$)

PARAMETER	SYMBOL	TEST CONDITION	V_{CC} (V)	Typ.	UNIT
Quiet Output Maximum Dynamic V_{OL}	V_{OLP}	$V_{IH} = 3.3\text{V}$, $V_{IL} = 0\text{V}$	3.3	0.8	V
Quiet Output Minimum Dynamic V_{OL}	$ V_{OLV} $	$V_{IH} = 3.3\text{V}$, $V_{IL} = 0\text{V}$	3.3	0.8	V

Capacitive Characteristics ($T_a = 25^\circ\text{C}$)

PARAMETER	SYMBOL	TEST CONDITION	V_{CC} (V)	Typ.	UNIT
Input Capacitance	C_{IN}	—	3.3	7	pF
Output Capacitance	C_{OUT}	—	0	8	pF
Power Dissipation Capacitance	C_{PD}	$f_{IN} = 10\text{MHz}$ (Note 11)	3.3	25	pF

(Note 11): C_{PD} is defined as the value of the internal equivalent capacitance which is calculated from the operating current consumption without load.

Average operating current can be obtained by the equation:

$$I_{CC(\text{opr.})} = C_{PD} \cdot V_{CC} \cdot f_{IN} + I_{CC}$$

Test Circuit

Fig.1

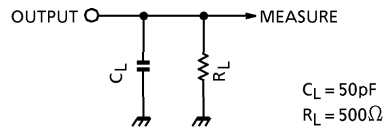

AC Waveform

Fig.2 t_{pLH} , t_{pHL}

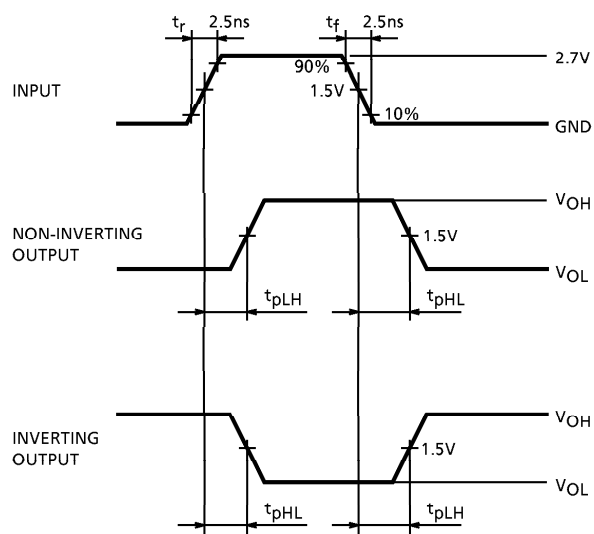

Outline Drawing
VSSOP16-P-0030-0.50

Unit: mm

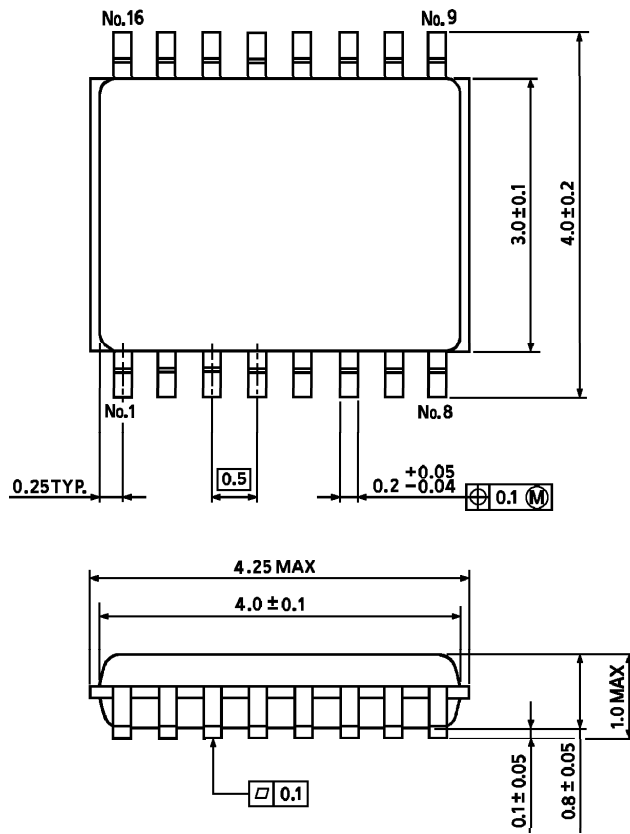

Weight: 0.02g (Typ.)