



Random Switching
Triac Driver

DESCRIPTION

The TD3052 consists of an AlGaAs LED optically coupled to a Random Phase triac driver chip. The TD3052 provides high input-to-output isolation and is designed to drive high-powered triacs. Typical uses include interfacing logic level control signals to equipment powered from 110Vac and 220Vac lines.

FEATURES

- Random phase switching
- 600V blocking voltage
- High input-to-output isolation (5kV MIN)
- 10mA turn-on (trigger) current
- High reliability

APPLICATIONS

- Home appliances
- Motor control
- Solid state relays
- Valve control
- Solenoids
- Dimmers
- High Power Triacs

OPTIONS/SUFFIXES*

- -H 0.4" Lead spacing (see mechanical dimension)
- -S Surface Mount Leadform Option
- -TR Tape and Reel Option
- -V Signifies VDE approval

NOTE: Suffixes listed above are not included in marking on device for part number identification.

ABSOLUTE MAXIMUM RATINGS*

PARAMETER	UNIT	MIN	TYP	MAX
Storage Temperature	°C	-55		125
Operating Temperature	°C	-40		85
Continuous Input Current	mA			40
Transient Input Current	mA			400
Reverse Input Control Voltage	V	6		
Output Power Dissipation	mW			500

*The values indicated are absolute stress ratings. Functional operation of the device is not implied at these or any conditions in excess of those defined in electrical characteristics section of this document. Exposure to Absolute Ratings may cause permanent damage to the device and may adversely affect reliability.

SCHEMATIC DIAGRAM

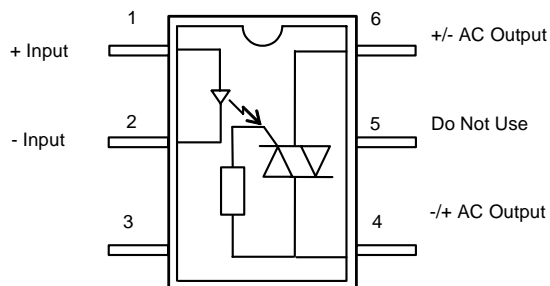

APPROVALS

- UL / C-UL Approved File #E201932
- VDE Approved, Lic # 40011225

ELECTRICAL CHARACTERISTICS - 25°C

PARAMETER	UNIT	MIN	TYP	MAX	TEST CONDITIONS
INPUT SPECIFICATIONS					
LED Forward Voltage	V		1.2	1.5	If = 10mA
LED Reverse Voltage	V	6	12		Ir = 10uA
Turn-On Current	m A		5	10	Io = 100mA
Turn-Off Current	m A		0.5		
OUTPUT SPECIFICATIONS					
Blocking Voltage	V	600			Io = 1uA
Continuous Load Current	m A			100	Iin = 5mA
Holding Current	μ A		250		
Leakage Current	μ A			1	Vo =600V
On-State Voltage	V		2	3	Iin = 5mA
Critical Rate of Rise	V / μ s	1000	1500		
COUPLED SPECIFICATIONS					
Isolation Voltage	V	5000			T = 1 minute
Coupled Capacitance	p F		2		

STATIC dv/dt TEST CIRCUIT

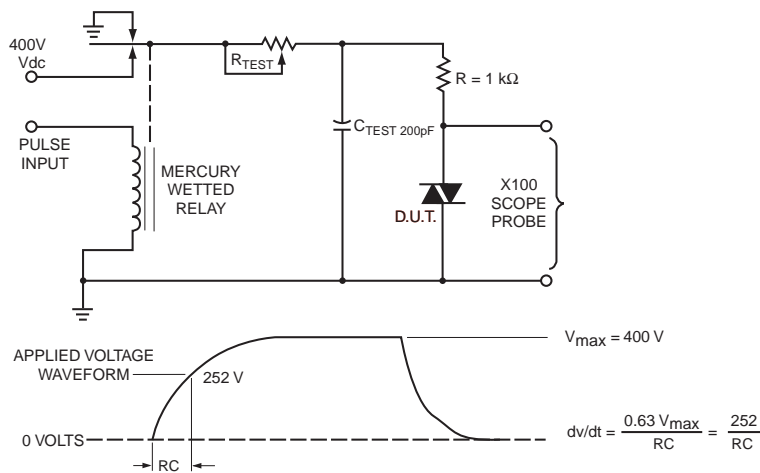

PERFORMANCE DATA

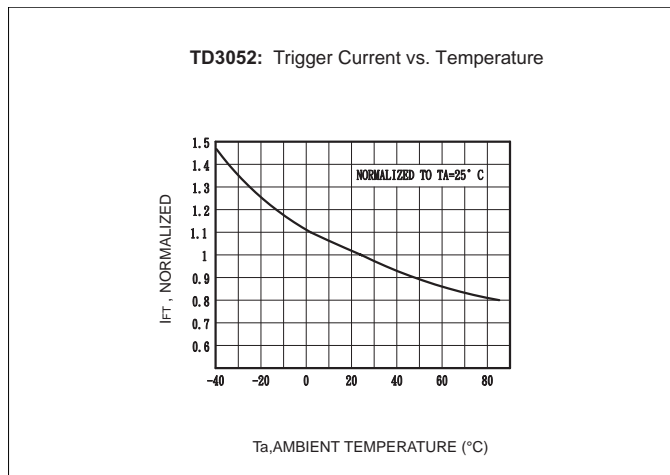
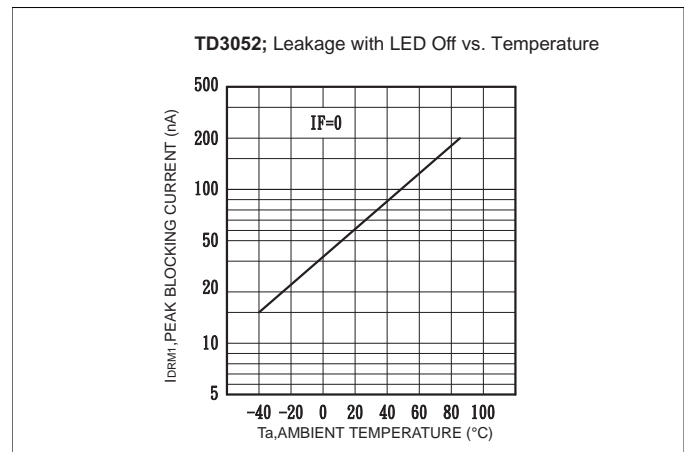
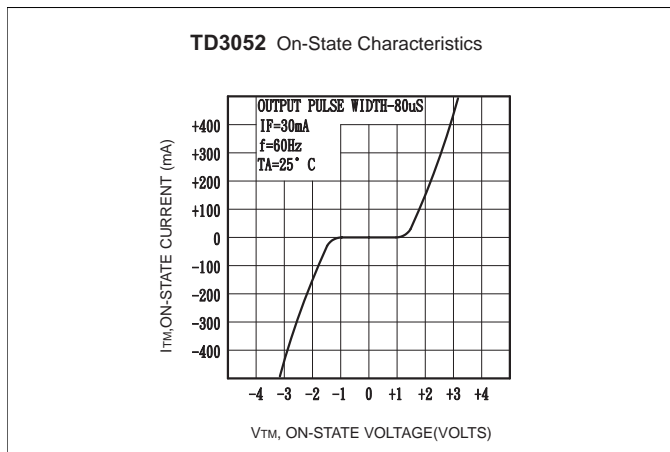
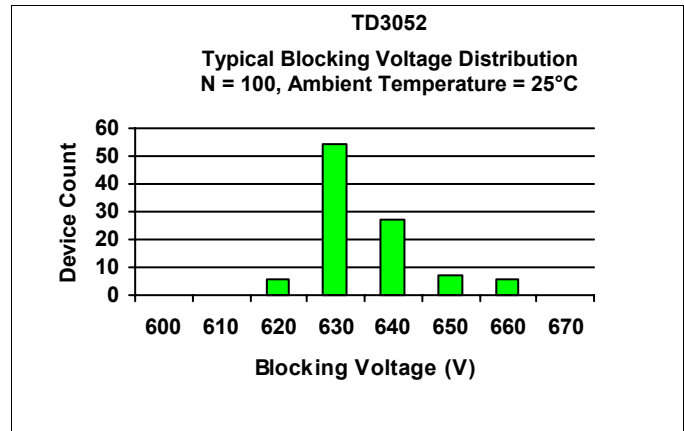
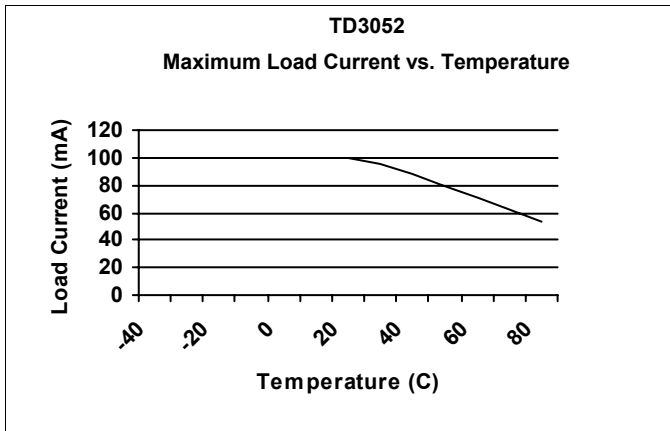

MECHANICAL DIMENSIONS

6 PIN DUAL-IN-LINE PACKAGE (Through-hole)

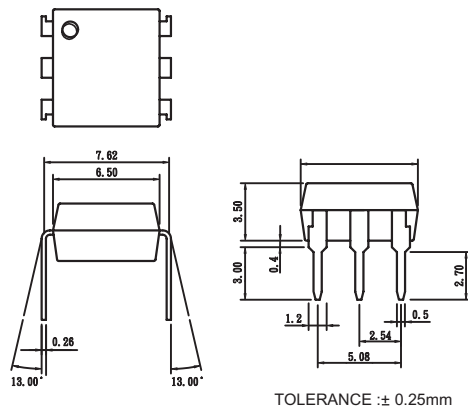

6 PIN SURFACE MOUNT DEVICE (SMD)

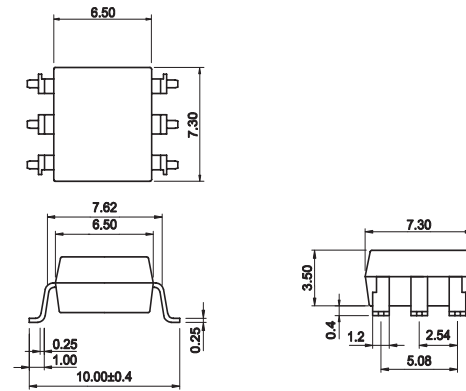

-H Suffix (0.4" / 10mm Lead Spacing)

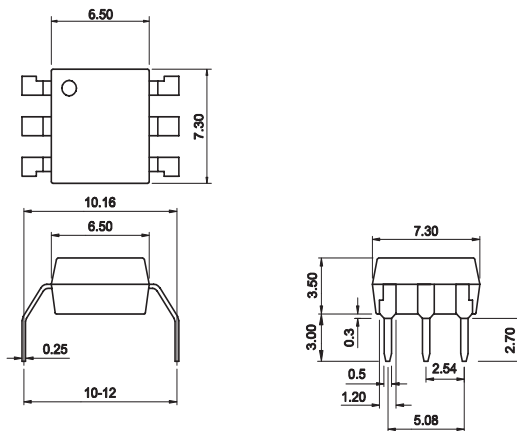

Unit (mm)

DISCLAIMER

Solid State Optronics (SSO) makes no warranties or representations with regards to the completeness and accuracy of this document. SSO reserves the right to make changes to product description, specifications at any time without further notice. SSO shall not assume any liability arising out of the application or use of any product or circuit described herein. Neither circuit patent licenses nor indemnity are expressed or implied. Except as specified in SSO's Standard Terms & Conditions, SSO disclaims liability for consequential or other damage, and we make no other warranty, expressed or implied, including merchantability and fitness for particular use.

LIFE SUPPORT POLICY

SSO does not authorize use of its devices in life support applications wherein failure or malfunction of a device may lead to personal injury or death. Users of SSO devices in life support applications assume all risks of such use and agree to indemnify SSO against any and all damages resulting from such use. Life support devices are defined as devices or systems which, (a) are intended for surgical implant into the body, or (b) support or sustain life, and (c) whose failure to perform when used properly in accordance with instructions for use can be reasonably expected to result in significant injury to the user, or (d) a critical component in any component of a life support device or system whose failure can be reasonably expected to cause failure of the life support device or system, or to affect its safety or effectiveness.