

FEATURES

- Stabilized, compact, and lightweight design.
- A board-in type mountable directly on the mother board of the set.
- Bus noise elimination through the use of a built-in white clip circuit.
- Usable for many purposes such as BS, CATV, etc., in addition to VCR and laser disc.

FUNCTIONAL DESCRIPTION

This modulator is designed for operation in NTSC-M systems. An RF antenna input is provided by an F Female connector and the combined RF output is provided on an F connector. The antenna input signals

appear on the RF output when the modulator portion is not operating, allowing for transparent operation with other household video appliances. When the modulator is in use, the modulated signal is seen at output and the antenna input spectrum is suppressed.

A tuner-out port is included in the VT5F9MN0007 as this unit is intended for applications where a local tuner capability is desired, such as in a combine VCR product. The tuner-out port is a sample of the antenna input spectrum and is always active. The modulator may also be used in satellite television applications. The output channel may be selected between NTSC channels 3 and 4, as designated in North America. The modulator operates from a +5 V source.

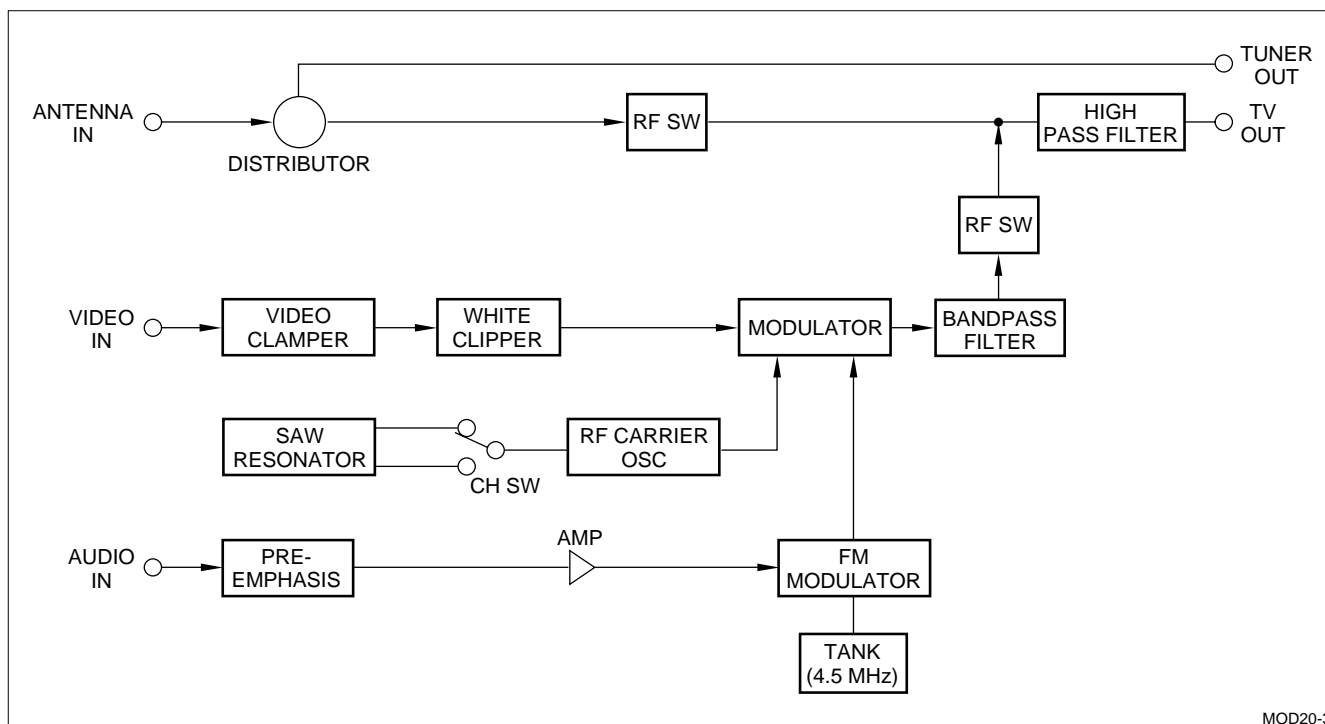

Figure 1. Block Diagram

SPECIFICATIONS

General Description

- U.S. standard transmission system
- NTCS color system
- Output channel 3, 4
- Output impedance 75 Ω , unbalanced
- Power source 5 (VDC) +B (MOD)

Test Condition

- Power source 5 \pm 0.1 (VDC) +B (MOD)
 - Ripple 30 mVp-p MAX.
- Unit setting conditions
 - Video: Apply 75% modulated color bar signal 1 Vp-p and set modulation factor and V/S ratio to specified values. For modulation factor setting, WHITE signal shall be 1 Vp-p V/S = 7/3, APL = 50%.
 - Audio: Add 1.24 Vp-p
- Ambient Conditions
 - Temperature 25°C \pm 3
 - Humidity 65% \pm 5 RH
 - If judgment is not in doubt, standard temperature may be considered as 15° to 30°C and humidity 45% to 85% RH.

Electrical Performance (RF MOD Portion)

- Video Characteristics
 - Input impedance 1 k Ω \pm 30%, unbalanced
 - Measure at 0 to 4.2 MHz
 - Input signal level 1 Vp-p synchronous (–)
 - When load of 82 Ω is applied
 - Modulation factor 77 \pm 7%
 - When load of 82 Ω is applied
 - V/S Ratio
 - 7 +0.25, -0. Input: Staircase wave 1 Vp-p synchronous (–)
 - 3 +0, -0.25. V/S = 7/3
 - Amplitude frequency characteristics +2 dB, -3 (MAX.)
 - Using 1 MHz as a standard in the 0 to 4.2 MHz range, measure at RF output using multiburst or sweep generator. Spectrum analyzer band is 300 kHz.
 - Differential gain 10% (MAX.)
 - Superimposed 3.58 MHz sine wave level shall be 20% of staircase wave level, measured in a modulation factor range of 65% to 75% and an APL range of 10% to 90%. However, differential gain of demodulator unit shall require correction.
- Differential phase 10° (MAX.)
 - Superimposed 3.58 MHz sine wave level shall be 20% of staircase wave level, measured in a modulation factor range of 65% to 75% and an APL range of 10% to 90%. However, differential gain of demodulator unit shall require correction.
- Change in modulation factor to APL \pm 5% (MAX.)
 - Within an APL range of 10% to 90% with APL 50% as referenced.
- S/N ratio 45 dB (p-p/rms MIN.)
 - Measure with standard demodulator output.
- Audio system characteristics
 - Input impedance 30 k Ω , unbalanced (MIN.)
 - Measure at 0.1 to 10 kHz
 - Input signal level 1.24 Vp-p
 - Amplitude frequency characteristics +2 dB, -3 dB
 - Using 1 kHz as a standard in the 100 Hz to 10 kHz range, measure deviation between reference.
 - Modulation factor 90 \pm 20%
 - 100% = \pm 25 kHz (\pm 25 kHz \pm 5 kHz)
 - Distortion rate 3% (MAX.)
 - S/N ratio 45 dB (MIN.), includes buzz
- Output system characteristics.
 - Video carrier frequency \pm 100 kHz (MAX.)
 - For test conditions, temperature shall be 25°C, and humidity 65% RH.
 - Audio frequency 4,500 kHz \pm 7 (MAX.)
 - For test conditions, temperature shall be 25°C, and humidity 65% RH.
 - Video output level 66 dB μ \pm 3 (MAX.)
 - p-p level (AT modulation): 75 Ω load
 - Audio output level difference (P/S ratio) 16 dB +4, -3 (MAX.)
 - Difference between video output level and audio output level (audio non-modulation)
 - Output terminal spurious
 - Specific frequency 16 dB +4, -3 (MAX.) fp – 4.5 MHz
 - Other frequencies 30 dB (MIN.). Measure as per FCC regulations: 0 to 1,000 MHz, excluding frequency in preceding remark.
 - Spurious radiation within the band 60 dB (MIN.)
 - Between fp and fs
 - Chroma beat (920 kHz) 50 dB (MIN.)
 - Apply 3.58 MHz 0.3 Vp-p sine wave to video input and measure using spectrum analyzer.
 - Output VSWR 3 (MAX.)
 - Worst point in the band at 75 Ω termination.

- Temperature characteristic. Measure at 0 to 60°C: check for variation from initial value.
 - Video modulation factor, temperature stability $\pm 10\%$
 - Video carrier, temperature stability ± 100 kHz
 - Audio modulation factor, temperature stability $\pm 12\%$
 - Audio carrier, temperature stability ± 15 kHz
 - Video output level temperature stability 66 ± 3 dB
 - Audio output level difference 50 ± 4 dB
 - Synchronous level, temperature stability $V/S = 7 \pm 0.5/3 \pm 0.5$
 - Differential gain, temperature stability 15% (MAX.)
 - Differential phase, temperature stability 15° (MAX.)
- Overall picture and total quality
 - Operation shall be problem-free. This paragraph is subject to sensory tests; therefore, any discrepancy arising between the parties concerned regarding final judgment shall be settled by mutual consent. (Limit standards shall be specified as needed.)
- Power source
 - Input voltage 5 VDC ± 0.2 +B (MOD)
 - Allowable ripple voltage: 50 mVp-p MAX.
 - Current consumption 30 mA (MAX.), 20 mA (TYP.)

Booster

- Insertion loss – ANT IN → TV OUT 6.5 dB (MAX.)
 - Measure at 55 MHz to 890 MHz
- Distribution loss –ANT IN → TUN OUT 6 dB (MAX.)
 - Measure at 55 MHz to 890 MHz
- Isolation 60 dB (MIN.), fs, fp
- VSWR, measure at 55 MHz to 890 MHz
 - ANT IN 4 (MAX.)
 - TUN OUT 3 (MAX.)
 - TV OUT
 - MOD OFF 4 (MAX.)
 - MOD ON 3 (MAX.) fs, fp
- Cross Modulation (dB μ). Input level = 100 dB μ (at 50 Ω terminal)
 - f1 = 183 MHz, f2 = 189 MHz, f(IM) = 177 MHz
 - 55 (MIN.)
 - f1 = 183 MHz, f2 = 189 MHz, f(IM) = 195 MHz
 - 55 (MIN.)
- Switching operation
 - ANT IN → TV OUT
 - Ground +B terminal
 - MOD OUT → TV OUT
 - When +5 V is applied across +B terminal

Durability Test

- Vibration test
 - Apply vibration of 2 mm full amplitude, 1,500 times/minute from three directions for 15 minutes each: there shall be no looseness, etc., and all performance requirements shall be satisfied.

- Impact test
 - Apply a 70 G impact using an impact tester; no damaged parts or looseness shall be observed, and performance shall not be remarkably affected.
- Moisture resistance
 - Test samples shall be left in an environment with temperature at 40°C $\pm 5^\circ\text{C}$ and relative humidity at 90 +0, -3%, for 500 hours, then left at normal temperature and humidity for 40 minutes. The unit shall then operate normally without malfunction.
- High temperature resistance
 - Test samples shall be left in a 70°C $\pm 2^\circ\text{C}$ bath for 500 hours, then at normal temperature and humidity for 40 minutes. The unit shall then operate normally without malfunction.
- Low temperature resistance
 - Test samples shall be left in a -20°C $\pm 2^\circ\text{C}$ bath for 500 hours, then at normal temperature and humidity for 40 minutes. The unit shall then operate normally without malfunction.
- Thermal shock resistance
 - 10 test cycles shall be conducted under the following conditions (see Figure 2) and test samples shall then be placed in a normal temperature and humidity atmosphere, cleared of excess water, left for 40 minutes. Subsequent operation shall be trouble-free.

Operating Conditions

- Operating guarantee conditions
 - Operation shall be trouble-free under $\pm 0^\circ\text{C}$ to 60°C and 85% RH MAX.
- Storage conditions
 - Temperature -10°C to 70°C
 - Humidity 90% RH (MAX.)

Electrostatic Test

- Electrostatic test (15 kV (+) and (-) polarities, 10 times each) shall be conducted on ANT IN and TV OUT terminals. Subsequent operation shall be trouble-free (C = 200 pF, R = 500 Ω).
- Antenna in/Tuner out
 - Yes/Yes

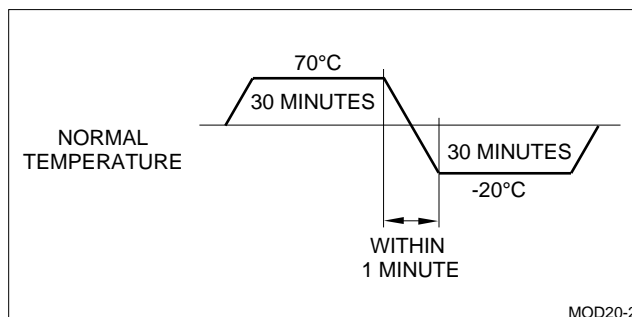

Figure 2. Thermal Shock Resistance

LIFE SUPPORT POLICY

SHARP components should not be used in medical devices with life support functions or in safety equipment (or similar applications where component failure would result in loss of life or physical harm) without the written approval of an officer of the SHARP Corporation.

LIMITED WARRANTY

SHARP warrants to its Customer that the Products will be free from defects in material and workmanship under normal use and service for a period of one year from the date of invoice. Customer's exclusive remedy for breach of this warranty is that SHARP will either (i) repair or replace, at its option, any Product which fails during the warranty period because of such defect (if Customer promptly reported the failure to SHARP in writing) or, (ii) if SHARP is unable to repair or replace, refund the purchase price of the Product upon its return to SHARP. This warranty does not apply to any Product which has been subjected to misuse, abnormal service or handling, or which has been altered or modified in design or construction, or which has been serviced or repaired by anyone other than Sharp. The warranties set forth herein are in lieu of, and exclusive of, all other warranties, express or implied. ALL EXPRESS AND IMPLIED WARRANTIES, INCLUDING THE WARRANTIES OF MERCHANTABILITY, FITNESS FOR USE AND FITNESS FOR A PARTICULAR PURPOSE, ARE SPECIFICALLY EXCLUDED. In no event will Sharp be liable, or in any way responsible, for any incidental or consequential economic or property damage.

The above warranty is also extended to Customers of Sharp authorized distributors with the following exception: reports of failures of Products during the warranty period and return of Products that were purchased from an authorized distributor must be made through the distributor. In case Sharp is unable to repair or replace such Products, refunds will be issued to the distributor in the amount of distributor cost.

SHARP reserves the right to make changes in specifications at any time and without notice. SHARP does not assume any responsibility for the use of any circuitry described; no circuit patent licenses are implied.

SHARP[®]**NORTH AMERICA**

SHARP Microelectronics
of the Americas
5700 NW Pacific Rim Blvd., M/S 20
Camas, WA 98607, U.S.A.
Phone: (360) 834-2500
Telex: 49608472 (SHARPCAM)
Facsimile: (360) 834-8903
<http://www.sharpsma.com>

EUROPE

SHARP Electronics (Europe) GmbH
Microelectronics Division
Sonninstraße 3
20097 Hamburg, Germany
Phone: (49) 40 2376-2286
Facsimile: (49) 40 2376-2232
<http://www.sharpsma.com>

ASIA

SHARP Corporation
Integrated Circuits Group
2613-1 Ichinomoto-Cho
Tenri-City, Nara, 632, Japan
Phone: (07436) 5-1321
Telex: LABOMETA-B J63428
Facsimile: (07436) 5-1532