



High Efficiency, Constant Current 12 Watt Boost White-LED Driver

FEATURES

- Operating Voltage:2.4V~6.5V
- High Operating Frequency: 1.5MHz
- High Efficiency: Up to 95%
- High Output Voltage: Up to 34V(max)
- High Output Power: Up to 12W(Vin=12V)
- Shutdown Current <math><1\mu A</math>
- 16V Output Over-voltage protection (min)
- Digital Dimming Control.
- Built-in Cycle-by Cycle Current-limiting.
- Built-in Soft-Start Function.
- 0.2V Low Reference Voltage(3%)
- Tiny SOT23-6 Package

APPLICATIONS

- LED Module
- LED Backlight for LCD Display(7"~21")
- Constant Current Source
- USB host

DESCRIPTION

The KB4313 step-up converter drives white LEDs with a constant current to provide backlight in cell phones, PDAs, and other hand-held devices. It features allowing series connection of the white LEDs so that the LED currents are identical for uniform brightness. An enable input can be pulsed repeatedly to adjust LED's brightness. The fast 1.5 MHz current-mode PWM control allows for smaller capacitor and inductor. Fault condition protection uses cycle-by-cycle current limiting to sense maximum inductor current, thermal protection and over-voltage protection. Also included soft-start eliminates inrush current during start-up. The 0.2V low reference voltage minimized the power loss across the current-setting resistor.

The KB4313 is available in SOT23-6 packages .

SIMPLIFIED BLOC DIAGRAM

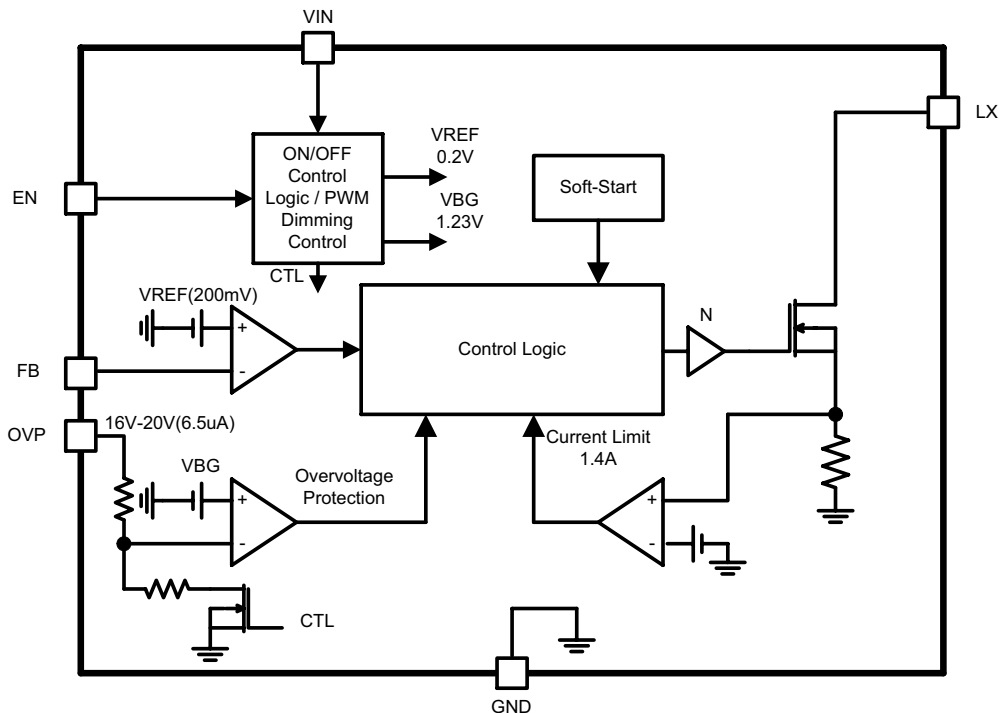



PIN CONFIGURATION

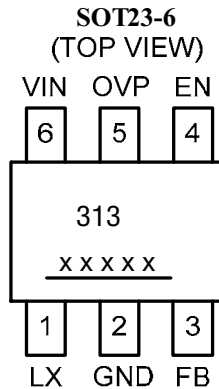

ORDER INFORMATION

Part number	Package	Marking
KB4313 GRE	SOT23-6, Green	313, Date Code with one bottom line

x x x x x : Date Code

PIN DESCRIPTION

Pin NO.	Symbol	I / O	Description
1	LX	I	Step-up Regulator N-MOS Drain. Place output diode and inductor.
2	GND	P	Ground
3	FB	I	Step-Up Regulator Feedback Input. Connect a sense resistor from FB to ground.
4	EN	I	Enable and Dimming Control Input. LED brightness and IC shutdown are controlled by the voltage on EN. Driving low for longer than 4ms to shutdown the IC.
5	OVP	I	Over-voltage protection input. Connect to the output.
6	VIN	P	Power supply.

ABSOLUTE MAXIMUM RATINGS (Note 1)

Parameter	Rated Value	Unit
VIN voltage	-0.3 to +6.5	V
LX , OVP voltage	-0.3 to +35	V
EN , FB to GND	-0.3 to +6.5	V
Switch Current (I _{LX})	1.4	A
Continuous power dissipation (SOT23-6 Ta=+25 °C)	0.35	W
Operating Junction Temperature Range	-35 to 85	°C
Lead Temperature (Soldering 5 sec)	260	°C
Storage Temperature	-65 to 125	°C
Package Thermal Resistance (Θ _{JA})	250	°C/W
ESD Susceptibility (HBM)	2	KV
ESD Susceptibility (MM)	200	V

Note1:Permanent device damage may occur if Absolute Maximum Ratings are exceeded. Exposure to absolute maximum rating conditions for extended periods may affect device reliability



High Efficiency, Constant Current 12 Watt Boost White-LED Driver

RECOMMENDED OPERATION CONDITIONS

Parameter	Symbol	Values			Unit
		Min.	Typ.	Max.	
Power supply voltage	V_{IN}	2.3	—	6.5	V
Operating temperature	Top	-30	+25	+85	°C

ELECTRICAL CHARACTERISTICS

($V_{IN}=2.5V$, $T_a=+25^{\circ}C$, unless otherwise noted)

Parameter	Symbol	Test Condition	Min.	Typ.	Max.	Units
Operating V_{IN} Range	V_{IN}	V_{IN} input Voltage	2.4	-	6.5	V
Under Voltage Thershold	UVLO	V_{IN} falling, 100mV hysteresis	2.1	2.2	2.3	V
Switch- Off Input Current	I_{IN1}	No Switching , $FB>0.2V$	-	100	120	uA
Shutdown Current	I_{IN3}	$EN=0V$	-	-	1	uA
Feedback Reference	V_{FB}		0.196	0.2	0.204	V
FB Input Bias Current	I_{FB}	$V_{FB}=0.2V$	-	-	1	uA
Over-voltage Threshold	V_{OVP}	V_{OUT} Rising	16	18	20	V
Over-voltage Hysteresis				2		V
OVP Leakage Current	I_{OVP}	$EN=0V$	-	-	1	uA
Output Voltage Line Regulation		$2.5V < V_{IN} < 6.0V$	-	0.1	-	%
Switching Frequency	f_{OSC}		1.2	1.5	1.6	MHz
Maximum Duty	D_{MAX}		-	90	-	%
Soft-Start charging time	t_{SS}		0.05	0.5		ms
Switching Current Limit	I_{LX}	$V_{IN}=3.0V$, duty cycle=80% ,	-	1.4	-	A
LX ON Resistance	R_{LX}	$V_{IN}=2.5V$, $I_{LX}=900mA$	-	0.3	-	Ω
LX Leakage Current	$I_{Leakage}$	$V_{LX}=16V$, $EN=0V$	-	-	1	uA
EN Input Current	I_{EN}	$EN=5V$	-	-	1	uA
EN Input Level	V_{IH}		2.0	-	-	V
	V_{IL}		-	-	0.5	V
EN low Shutdown Delay				4		ms
EN Low Cycle Time	t_{CYCL}	Note(1)	0.05		4	ms
EN High Cycle Time	t_{CYCH}	Note(1)	0.05		4	ms

Note(1): t_{CYCL} and t_{CYCH} are included rising time and falling time of PWM signal.

Recommended PCB Layout

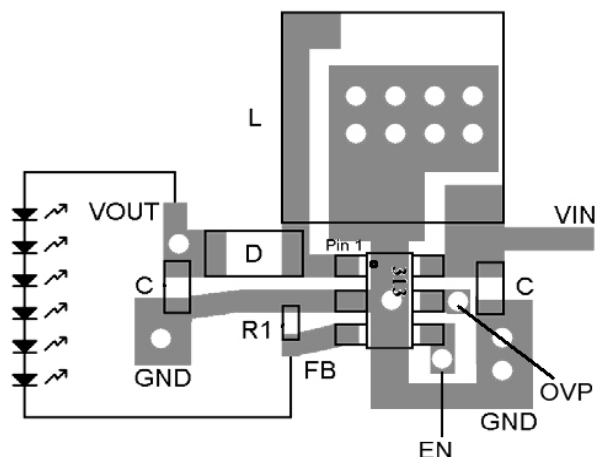



High Efficiency, Constant Current 12 Watt Boost White-LED Driver

TYPICAL PERFORMANCE CHARACTERISTICS

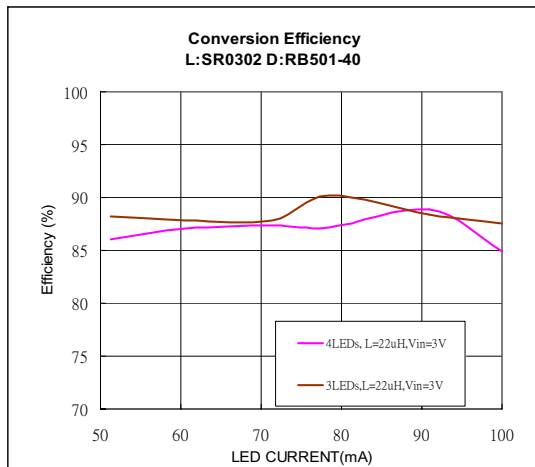
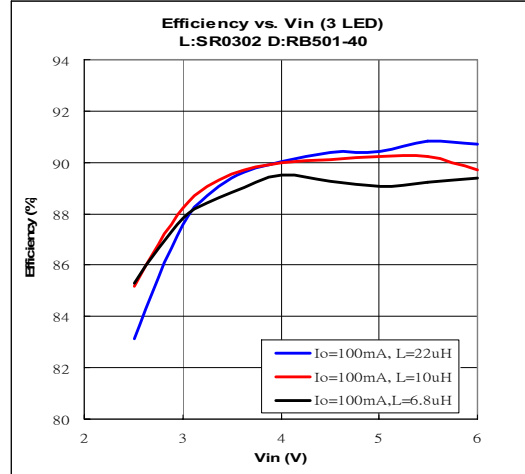
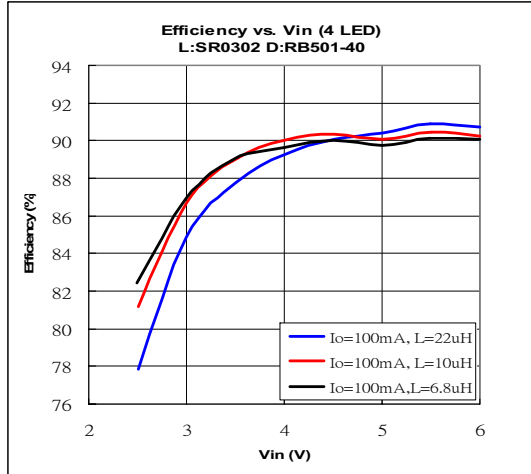

CH1:LX CH3:V_{OUT} Ripple CH4:I_{LX}

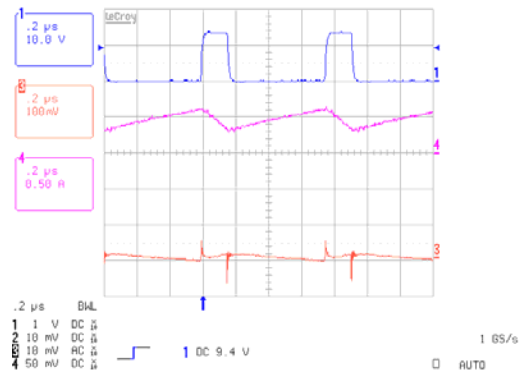

Switching Transient Waveform

CH1:EN CH3:FB

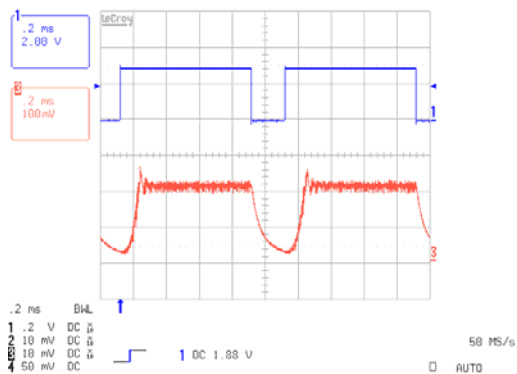

PWM Dimming Control Using the EN Pin

CH1:EN CH3:FB CH4:I_{IN}

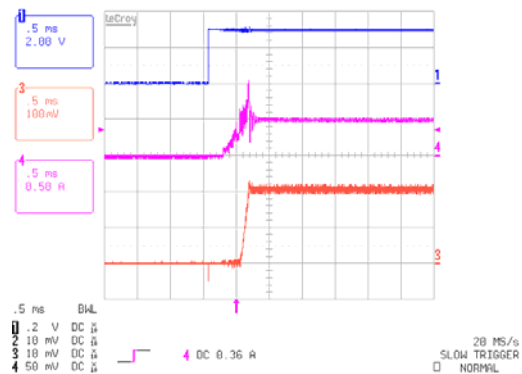

Start-Up Waveform



APPLICATION CIRCUIT

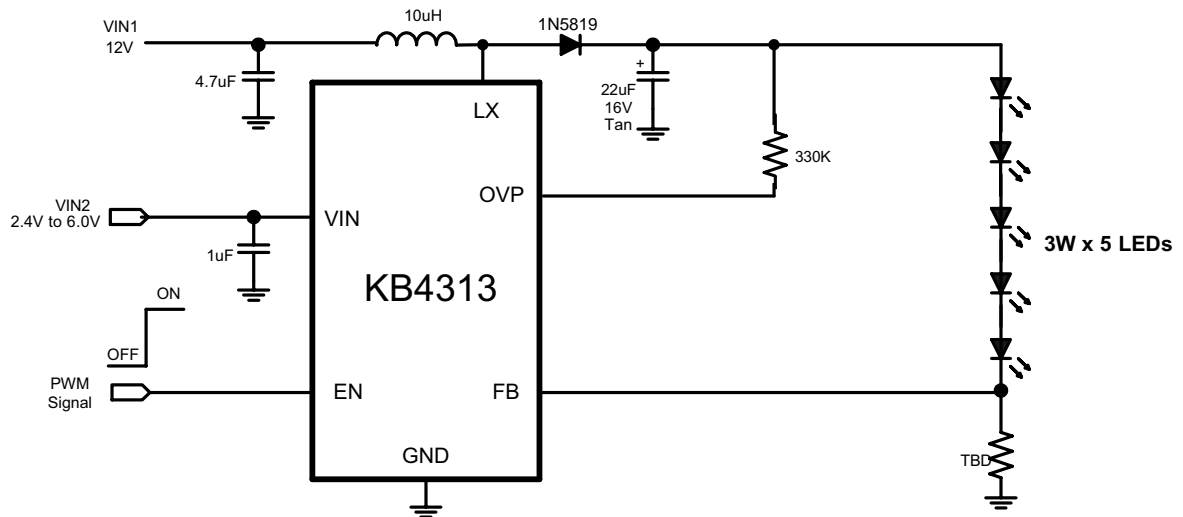

Figure 1a. kB4313 Typical Application Circuit with 700mA 18V Output .

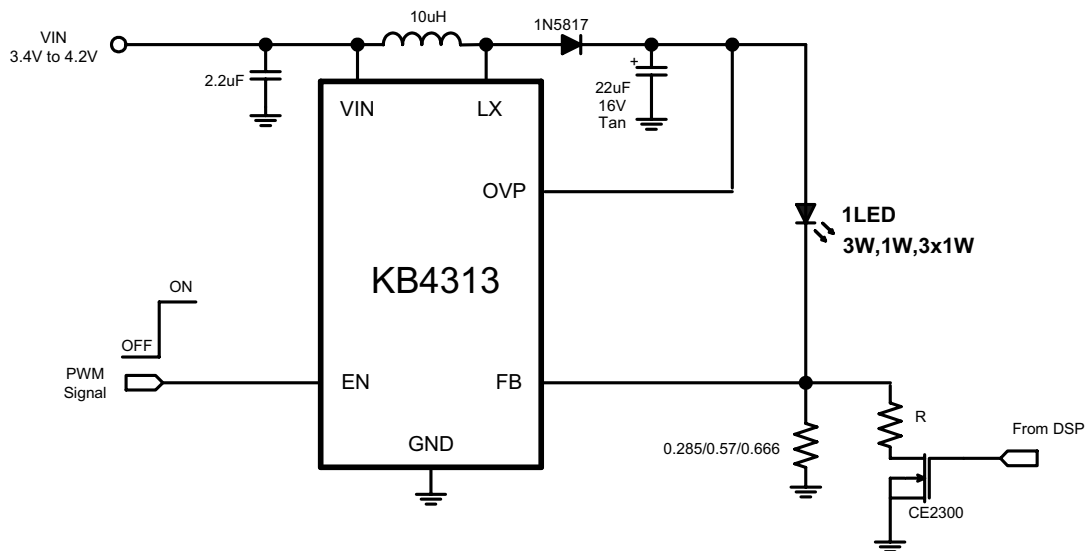

Figure 1b. kB4313 Typical Application Circuit with 700mA/350mA/300mA Output .



High Efficiency, Constant Current 12 Watt Boost White-LED Driver

APPLICATION CIRCUIT

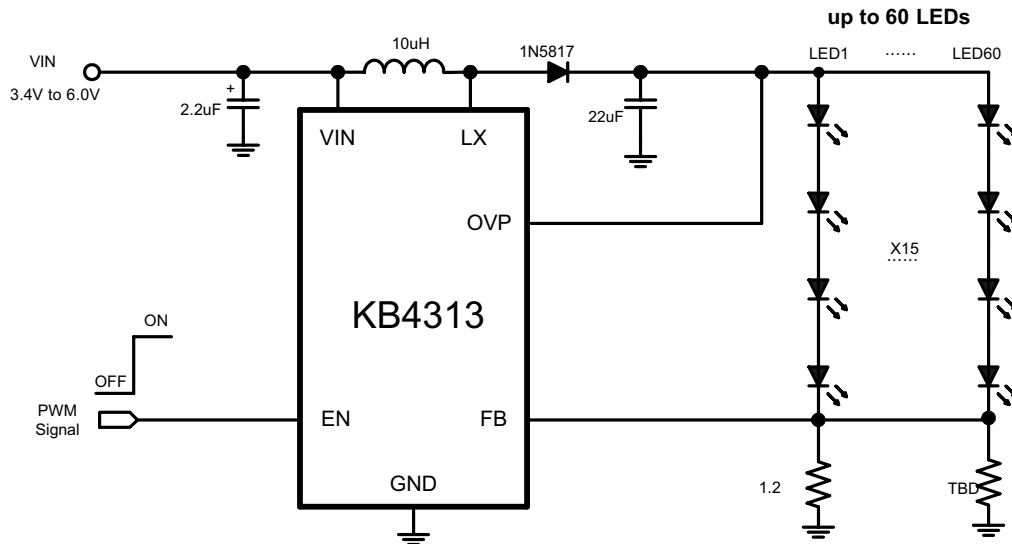

Figure 1c. kB4313 for 8" Panel LED Back light unit .

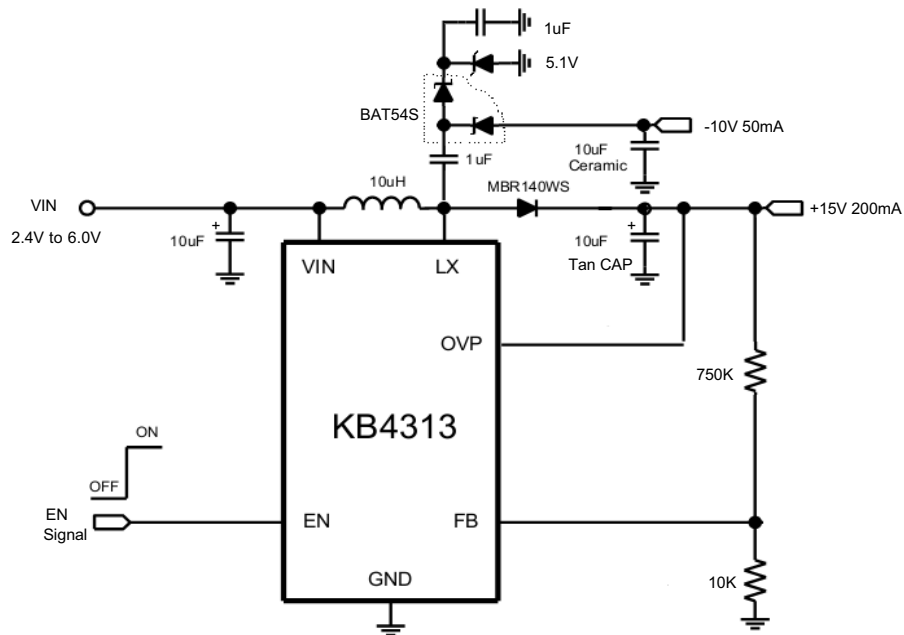

Figure 1d. kB4313 Typical Application Circuit with +15V -10V Output .



Function Description

The KB4313 is a high efficiency and constant current DC-DC converter IC which is designed primarily for use in LED module applications. The output voltage of the step-up converter can be set from V_{in} to 16V with external sense resistor. The device suits to drive series-connected LEDs and provides even illumination by sourcing the same output current through each LED. KB4313 also consists of a logic shutdown , cycle-by-cycle current-limited , soft-start functions.

Logic control input or PWM duty cycle control allows easy adjustment of LEDs brightness and on/off control. The average LED current is proportionable the duty-cycle of the PWM signal. Typical PWM frequency should be between 100Hz and 1kHz.

The boost converter operates in current-mode PWM and a constant frequency of 1.5 MHz. Depending on duty cycle of each switching cycle can regulate output voltage. On the rising edge of the internal clock , the control and driver logic block sets internal flip-flop when the output voltage is too low, which turns on the N-MOS. The external inductor current ramps up linearly, storing energy in a magnetic filed. Once peak current of inductor over trans-conductance output level , the N-MOS turns off, the flip-flop resets, and external schottky diode turns on. This forces the current through the inductor to ramp back down, transferring the energy stored in the magnetic field to the output capacitor and LEDs. To reduce external component amount , the device will be built-in internal loop compensation.

Enable Control

Digital logic of EN provides an electrical ON/OFF control of the power supply. Connecting this pin to ground or to any voltage less than 0.5V and sustain the level over 4ms will completely turn off the regulator. In this state, current drain from the input supply is less than 1uA, the internal reference, error amplifier, comparators, and biasing circuitry turn off . If holding time of low level is less than 3ms on this pin, then the device only shutdown driver logic block.

Dimming Control

Digital logic of EN also provides LEDs brightness control by applying a PWM signal on EN pin. With this way, the LEDs operate with either zero or full current . The average LED current is proportional to the duty-cycle of the PWM signal. Typical PWM frequency should be between 100Hz and 1kHz. Output current is given by:

$$I_{LED} = \frac{200mV \times T_{ON-PWM}}{R_{SENSE} \times T_{S-PWM}}$$

Where:

T_{ON-PWM} : On time of PWM signal

T_{S-PWM} : A cycle time of PWM signal

If dimming control is not required , EN works as a simple on/off control. Drive EN high to enable the device , or drive EN low for shutdown.



Soft-Start

Soft-start allows a gradual increase of the internal current-limit level for the step-up converter during power-up to reduce input surge currents. As the internal current source charges the internal soft-start capacitor, the peak N-MOS current is limited by the voltage on the capacitor. In another story, when toggle or a logic-level transition on EN pin from low to high, soft-start function must work to enable constant current charging internal capacitor. When soft-start process has finished or appeared falling edge of PWM signal on EN pin , soft-start capacitor must be discharged to ground level.

Cycle-by-Cycle Over-Current Protection

The KB4313 provides cycle-by-cycle over-current protection. Current limit is accomplished using a separate dedicated comparator. The cycle-by-cycle current limit abbreviates the on-time of the N-MOS in event that the current of flowing N-MOS is greater than the current limit value. The current-limit feature protection against a hard short or over-current fault at the output.

Over-Voltage Protection

If V_{OUT} is above 16V or LEDs are disconnected from the circuit, the FB pin is similar to pull down to ground with a sense resistor. This will cause N-MOS to switch with a maximum duty cycle and come out output over-voltage. This may cause the LX pin voltage to exceed its maximum voltage rating to damage built-in N-MOS. In the state, the OVLO protection circuitry stops the internal N-MOS . When V_{OUT} falls below 16V, IC will automatically recover normal operation.

Power dissipation consideration

The KB4313 maximum power dissipation depends on the thermal resistance of the IC package and circuit board, the temperature difference between the die junction and ambient air, and the rate of any airflow. The power dissipation in the device depends on the operating conditions of the regulator.

The step-up converter dissipates power across the internal N-MOS as the controller ramps up the inductor current. In continuous condition, the power dissipated internally can be approximated by :

$$P_{boost} = \left[\left(\frac{I_O \times V_O}{V_{in}} \right)^2 + \frac{1}{12} \left(\frac{V_{in} \times D}{f_{OSC} \times L} \right)^2 \right] \times R_{DS(ON)} \times D$$

where

I_O : It is the load current.

f_{OSC} : It is a switching frequency.



Applications Information

External components of main boost converter can be designed by performing simple calculations. It need to follow regulation by the output voltage and the maximum load current, as well as maximum and minimum input voltages. Begin by selecting an inductor value. Once L is know, choose the diode and capacitors.

Boost inductor

Inductor selection depends on input voltage, output voltage, maximum current , switching frequency and availability of inductor values. The following boost circuit equations are useful in choosing the inductor values based on the application. They allow the trading of peak current and inductor value while allowing for consideration of component availability and cost.

The peak inductor current is given by:

$$I_{Lpeak} = I_{LAVG} + \frac{\Delta I_L}{2}$$

$$I_{LAVG} = \frac{I_O}{1-D}$$

where:

ΔI_L is the inductor peak-to-peak current ripple and is decided by:

$$\Delta I_L = \frac{V_{in}}{L} \times \frac{D}{f_{OSC}}$$

D is the MOSFET turn on ratio and is decided by:

$$D = \frac{V_O - V_{in}}{V_O}$$

f_{OSC} is the switching frequency.

The inductor should be chosen to be able to handle this current and inductor saturation current rating should be greater than I_{PEAK} .

Diode selection

The output diode has average current of I_O , and peak current the same as the inductor's peak current and a voltage rating at least 1.5 times the output voltage. Schottky diode is recommended and it should be able to handle those current.

Output Capacitor

The KB4313 is specially compensated to be stable with capacitors which have a worst- case minimum value of 1uF at the particular V_{OUT} being set. Output ripple voltage requirements also determine the minimum value and type of capacitors. Output ripple voltage consists of two components the voltage drop caused by the switching current through the ESR of the output capacitor and the charging and discharging of the output capacitor:

$$V_{RIPPLE} = I_{LPEAK} \times ESR + \frac{V_O - V_{in}}{V_O} \times \frac{I_O}{C_{OUT} \times f_{OSC}}$$

For low ESR ceramic capacitors, the output ripple is dominated by the charging or discharging of the output capacitor.



PACAGE DESCRIPTION

Small Outline SOT23-6

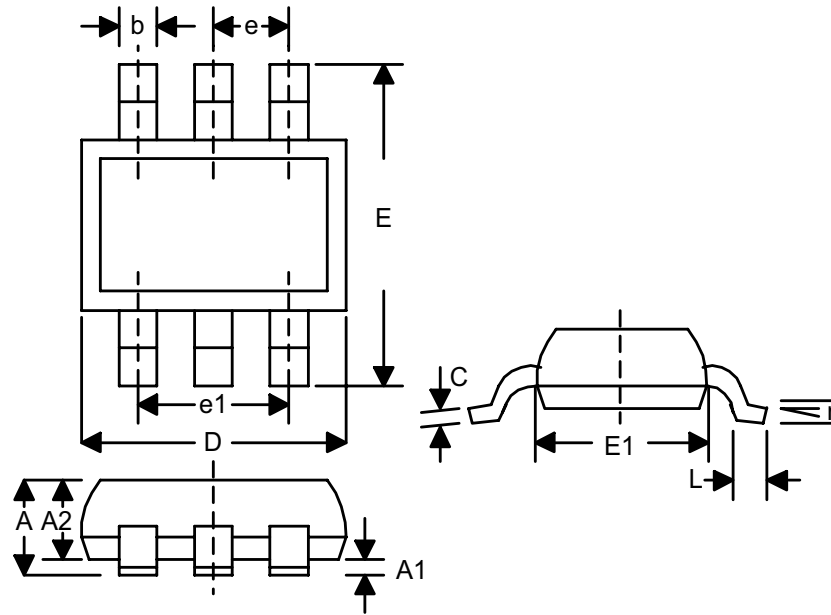

SYMBOL	INCHES		MILLIMETERS		NOTES
	MIN	MAX	MIN	MAX	
A	0.035	0.057	0.90	1.45	-
A1	0.000	0.006	0.00	0.15	-
A2	0.035	0.051	0.90	1.30	-
b	0.010	0.020	0.25	0.50	-
C	0.003	0.008	0.08	0.20	-
D	0.110	0.122	2.80	3.10	-
E	0.102	0.118	2.60	3.00	-
E1	0.059	0.069	1.50	1.75	-
L	0.014	0.022	0.35	0.55	-
e	0.037ref		0.95ref		-
e1	0.075ref		1.90ref		-
r	0 ⁰	10 ⁰	0 ⁰	10 ⁰	-