



# LPC2460

Flashless 16-bit/32-bit micro; Ethernet, CAN, ISP/IAP, USB 2.0 device/host/OTG, external memory interface

Rev. 00.01 — 5 October 2007

Preliminary data sheet

## 1. General description

---

NXP Semiconductors designed the LPC2460 microcontroller around a 16-bit/32-bit ARM7TDMI-S CPU core with real-time debug interfaces that include both JTAG and embedded trace. The LPC2460 is flashless. The LPC2460 can execute both 32-bit ARM and 16-bit Thumb instructions. Support for the two instruction sets means engineers can choose to optimize their application for either performance or code size at the sub-routine level. When the core executes instructions in Thumb state it can reduce code size by more than 30 % with only a small loss in performance while executing instructions in ARM state maximizes core performance.

The LPC2460 microcontroller is ideal for multi-purpose communication applications. It incorporates a 10/100 Ethernet Media Access Controller (MAC), a USB full-speed Device/Host/OTG Controller with 4 kB of endpoint RAM, four UARTs, two Controller Area Network (CAN) channels, an SPI interface, two Synchronous Serial Ports (SSP), three I<sup>2</sup>C interfaces, and an I<sup>2</sup>S interface. Supporting this collection of serial communications interfaces are the following feature components; an on-chip 4 MHz internal precision oscillator, 98 kB of total RAM consisting of 64 kB of local SRAM, 16 kB SRAM for Ethernet, 16 kB SRAM for general purpose DMA, 2 kB of battery powered SRAM, and an External Memory Controller (EMC). These features make this device optimally suited for communication gateways and protocol converters. Complementing the many serial communication controllers, versatile clocking capabilities, and memory features are various 32-bit timers, an improved 10-bit ADC, 10-bit DAC, two PWM units, four external interrupt pins, and up to 160 fast GPIO lines. The LPC2460 connects 64 of the GPIO pins to the hardware based Vector Interrupt Controller (VIC) that means these external inputs can generate edge-triggered interrupts. All of these features make the LPC2460 particularly suitable for industrial control and medical systems.

## 2. Features

---

- ARM7TDMI-S processor, running at up to 72 MHz.
- 98 kB on-chip SRAM includes:
  - ◆ 64 kB of SRAM on the ARM local bus for high performance CPU access.
  - ◆ 16 kB SRAM for Ethernet interface. Can also be used as general purpose SRAM.
  - ◆ 16 kB SRAM for general purpose DMA use also accessible by the USB.
  - ◆ 2 kB SRAM data storage powered from the Real-Time Clock (RTC) power domain.
- Dual Advanced High-performance Bus (AHB) system allows simultaneous Ethernet DMA, and USB DMA with no contention.
- EMC provides support for asynchronous static memory devices such as RAM, ROM and flash, as well as dynamic memories such as Single Data Rate SDRAM.
- Advanced Vectored Interrupt Controller (VIC), supporting up to 32 vectored interrupts.

- General Purpose AHB DMA controller (GPDMA) that can be used with the SSP, I<sup>2</sup>S, and SD/MMC interface as well as for memory-to-memory transfers.
- Serial Interfaces:
  - ◆ Ethernet MAC with MII/RMII interface and associated DMA controller. These functions reside on an independent AHB bus.
  - ◆ USB 2.0 full-speed dual port Device/Host/OTG Controller with on-chip PHY and associated DMA controller.
  - ◆ Four UARTs with fractional baud rate generation, one with modem control I/O, one with IrDA support, all with FIFO.
  - ◆ CAN controller with two channels.
  - ◆ SPI controller.
  - ◆ Two SSP controllers, with FIFO and multi-protocol capabilities. One is an alternate for the SPI port, sharing its interrupt. SSPs can be used with the GPDMA controller.
  - ◆ Three I<sup>2</sup>C-bus interfaces (one with open-drain and two with standard port pins).
  - ◆ I<sup>2</sup>S (Inter-IC Sound) interface for digital audio input or output. It can be used with the GPDMA.
- Other peripherals:
  - ◆ SD/MMC memory card interface.
  - ◆ 160 General purpose I/O pins with configurable pull-up/down resistors.
  - ◆ 10-bit ADC with input multiplexing among 8 pins.
  - ◆ 10-bit DAC.
  - ◆ Four general purpose timers/counters with 8 capture inputs and 10 compare outputs. Each timer block has an external count input.
  - ◆ Two PWM/timer blocks with support for three-phase motor control. Each PWM has an external count inputs.
  - ◆ RTC with separate power domain, clock source can be the RTC oscillator or the APB clock.
  - ◆ 2 kB SRAM powered from the RTC power pin, allowing data to be stored when the rest of the chip is powered off.
  - ◆ WatchDog Timer (WDT). The WDT can be clocked from the internal RC oscillator, the RTC oscillator, or the APB clock.
- Standard ARM test/debug interface for compatibility with existing tools.
- Emulation trace module supports real-time trace.
- Single 3.3 V power supply (3.0 V to 3.6 V).
- Three reduced power modes: idle, sleep, and power-down.
- Four external interrupt inputs configurable as edge/level sensitive. All pins on PORT0 and PORT2 can be used as edge sensitive interrupt sources.
- Processor wake-up from Power-down mode via any interrupt able to operate during Power-down mode (includes external interrupts, RTC interrupt, USB activity, Ethernet wake-up interrupt, CAN bus activity, PORT0/2 pin interrupt).
- Two independent power domains allow fine tuning of power consumption based on needed features.
- Each peripheral has its own clock divider for further power saving. These dividers help reducing active power by 20 - 30 %.
- Brownout detect with separate thresholds for interrupt and forced reset.
- On-chip power-on reset.
- On-chip crystal oscillator with an operating range of 1 MHz to 24 MHz.

- 4 MHz internal RC oscillator trimmed to 1 % accuracy that can optionally be used as the system clock. When used as the CPU clock, does not allow CAN and USB to run.
- On-chip PLL allows CPU operation up to the maximum CPU rate without the need for a high frequency crystal. May be run from the main oscillator, the internal RC oscillator, or the RTC oscillator.
- Boundary scan for simplified board testing.
- Versatile pin function selections allow more possibilities for using on-chip peripheral functions.

### 3. Applications

- Industrial control
- Medical systems
- Protocol converter
- Communications

### 4. Ordering information

Table 1. Ordering information

Type number	Package			Version
	Name	Description		
LPC2460FBD208	LQFP208	plastic low profile quad flat package; 208 leads; body 28 × 28 × 1.4 mm		SOT459-1
LPC2460FET208	TFBGA208	plastic thin fine-pitch ball grid array package; 208 balls; body 15 × 15 × 0.7 mm		SOT950-1

#### 4.1 Ordering options

Table 2. Ordering options

Type number	Flash (kB)	SRAM (kB)					External bus	Ethernet	USB OTG/OHC/DEV + 4 kB FIFO	CAN channels	SD/MMC	GP DMA	ADC channels	DAC channels	Temp range
		Local bus	Ethernet buffer	GP/USB	RTC	Total									
LPC2460FBD208	N/A	64	16	16	2	98	Full 32-bit	MII/RMII	yes	2	yes	yes	8	1	-40 °C to +85 °C
LPC2460FET208	N/A	64	16	16	2	98	Full 32-bit	MII/RMII	yes	2	yes	yes	8	1	-40 °C to +85 °C

5. Block diagram

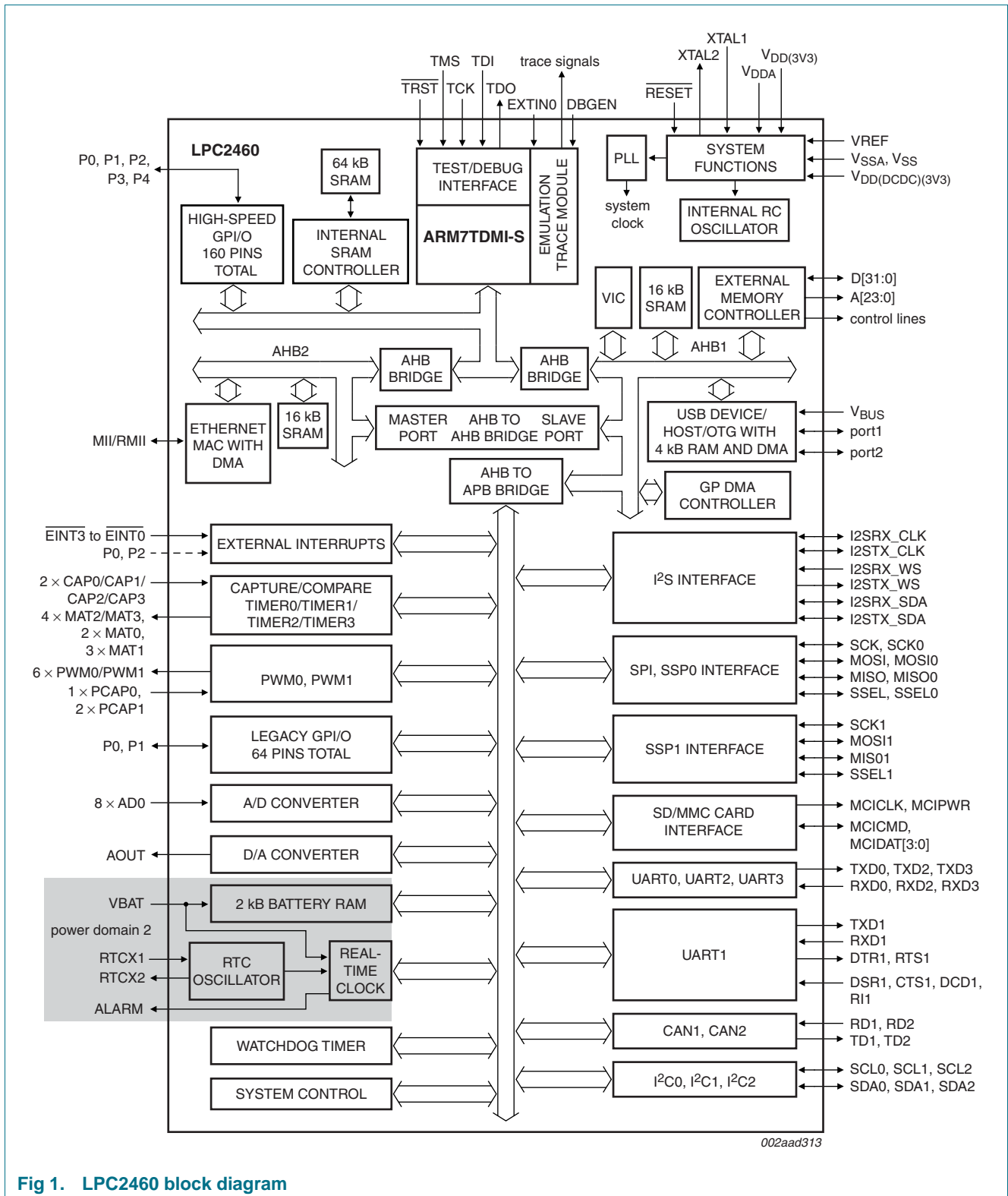

Fig 1. LPC2460 block diagram

## 6. Pinning information

### 6.1 Pinning

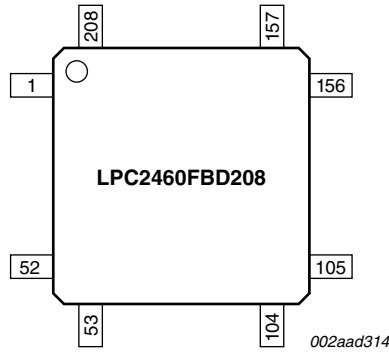

Fig 2. LPC2460 pinning LQFP208 package

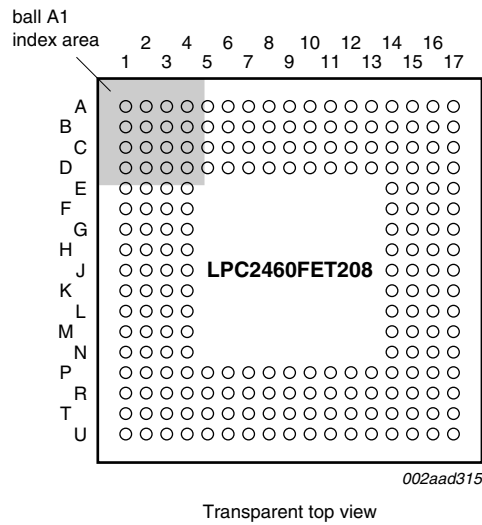

Fig 3. LPC2460 pinning TFBGA208 package

Table 3. Pin allocation table

Pin	Symbol	Pin	Symbol	Pin	Symbol	Pin	Symbol
<b>Row A</b>							
1	P3[27]/D27/ CAP1[0]/PWM1[4]	2	V <sub>SSIO</sub>	3	P1[0]/ENET_TXD0	4	P4[31]/CS1
5	P1[4]/ENET_TX_EN	6	P1[9]/ENET_RXD0	7	P1[14]/ENET_RX_ER	8	P1[15]/ ENET_REF_CLK/ ENET_RX_CLK
9	P1[17]/ENET_MDIO	10	P1[3]/ENET_TXD3/ MCICMD/PWM0[2]	11	P4[15]/A15	12	V <sub>SSIO</sub>
13	P3[20]/D20/ PWM0[5]/DSR1	14	P1[11]/ENET_RXD2/ MCIDAT2/PWM0[6]	15	P0[8]/I2STX_WS/ MISO1/MAT2[2]	16	P1[12]/ENET_RXD3/ MCIDAT3/PCAP0[0]

Table 3. Pin allocation table ...continued

Pin	Symbol	Pin	Symbol	Pin	Symbol	Pin	Symbol
17	P1[5]/ENET_TX_ER/ MCIPWR/PWM0[3]	-	-	-	-	-	-
<b>Row B</b>							
1	P3[2]/D2	2	P3[10]/D10	3	P3[1]/D1	4	P3[0]/D0
5	P1[1]/ENET_TXD1	6	V <sub>SSIO</sub>	7	P4[30]/CS <sub>0</sub>	8	P4[24]/OE
9	P4[25]/WE	10	P4[29]/BLS3/ MAT2[1]/RXD3	11	P1[6]/ENET_TX_CLK/ MCIDAT0/PWM0[4]	12	P0[4]/I2SRX_CLK/RD2/ CAP2[0]
13	V <sub>DD(3V3)</sub>	14	P3[19]/D19/ PWM0[4]/DCD1	15	P4[14]/A14	16	P4[13]/A13
17	P2[0]/PWM1[1]/TXD1/ TRACECLK	-	-	-	-	-	-
<b>Row C</b>							
1	P3[13]/D13	2	TDI	3	RTCK	4	P0[2]/TXD0
5	P3[9]/D9	6	P3[22]/D22/ PCAP0[0]/RI1	7	P1[8]/ENET_CRS_DV/ ENET_CRS	8	P1[10]/ENET_RXD1
9	V <sub>DD(3V3)</sub>	10	P3[21]/D21/ PWM0[6]/DTR1	11	P4[28]/BLS2/ MAT2[0]/TXD3	12	P0[5]/I2SRX_WS/TD2/ CAP2[1]
13	P0[7]/I2STX_CLK/SCK1 /MAT2[1]	14	P0[9]/I2STX_SDA/ MOSI1/MAT2[3]	15	P3[18]/D18/ PWM0[3]/CTS1	16	P4[12]/A12
17	V <sub>DD(3V3)</sub>	-	-	-	-	-	-
<b>Row D</b>							
1	TRST	2	P3[28]/D28/ CAP1[1]/PWM1[5]	3	TDO	4	P3[12]/D12
5	P3[11]/D11	6	P0[3]/RXD0	7	V <sub>DD(3V3)</sub>	8	P3[8]/D8
9	P1[2]/ENET_TXD2/ MCICLK/PWM0[1]	10	P1[16]/ENET_MDC	11	V <sub>DD(DCDC)(3V3)</sub>	12	V <sub>SSCORE</sub>
13	P0[6]/I2SRX_SDA/ SSEL1/MAT2[0]	14	P1[7]/ENET_COL/ MCIDAT1/PWM0[5]	15	P2[2]/PWM1[3]/ CTS1/PIPESTAT1	16	P1[13]/ENET_RX_DV
17	P2[4]/PWM1[5]/ DSR1/TRACESYNC	-	-	-	-	-	-
<b>Row E</b>							
1	P0[26]/AD0[3]/ AOUT/RXD3	2	TCK	3	TMS	4	P3[3]/D3
14	P2[1]/PWM1[2]/RXD1/ PIPESTAT0	15	V <sub>SSIO</sub>	16	P2[3]/PWM1[4]/ DCD1/PIPESTAT2	17	P2[6]/PCAP1[0]/ RI1/TRACEPKT1
<b>Row F</b>							
1	P0[25]/AD0[2]/ I2SRX_SDA/TXD3	2	P3[4]/D4	3	P3[29]/D29/ MAT1[0]/PWM1[6]	4	DBGEN
14	P4[11]/A11	15	P3[17]/D17/ PWM0[2]/RXD1	16	P2[5]/PWM1[6]/ DTR1/TRACEPKT0	17	P3[16]/D16/ PWM0[1]/TXD1
<b>Row G</b>							
1	P3[5]/D5	2	P0[24]/AD0[1]/ I2SRX_WS/CAP3[1]	3	V <sub>DD(3V3)</sub>	4	V <sub>DDA</sub>
14	NC	15	P4[27]/BLS1	16	P2[7]/RD2/ RTS1/TRACEPKT2	17	P4[10]/A10

Table 3. Pin allocation table ...continued

Pin	Symbol	Pin	Symbol	Pin	Symbol	Pin	Symbol
<b>Row H</b>							
1	P0[23]/AD0[0]/ I2SRX_CLK/CAP3[0]	2	P3[14]/D14	3	P3[30]/D30/ MAT1[1]/RTS1	4	V <sub>DD(DCDC)</sub> (3V3)
14	V <sub>SSIO</sub>	15	P2[8]/TD2/ TXD2/TRACEPKT3	16	P2[9]/ USB_CONNECT1/ RXD2/EXTIN0	17	P4[9]/A9
<b>Row J</b>							
1	P3[6]/D6	2	V <sub>SSA</sub>	3	P3[31]/D31/MAT1[2]	4	NC
14	P0[16]/RXD1/ SSEL0/SSEL	15	P4[23]/A23/ RXD2/MOSI1	16	P0[15]/TXD1/ SCK0/SCK	17	P4[8]/A8
<b>Row K</b>							
1	VREF	2	RTCX1	3	$\overline{\text{RSTOUT}}$	4	V <sub>SSCORE</sub>
14	P4[22]/A22/ TXD2/MISO1	15	P0[18]/DCD1/ MOSI0/MOSI	16	V <sub>DD(3V3)</sub>	17	P0[17]/CTS1/ MISO0/MISO
<b>Row L</b>							
1	P3[7]/D7	2	RTCX2	3	V <sub>SSIO</sub>	4	P2[30]/DQMOUT2/ MAT3[2]/SDA2
14	NC	15	P4[26]/BLS0	16	P4[7]/A7	17	P0[19]/DSR1/ MCICLK/SDA1
<b>Row M</b>							
1	P3[15]/D15	2	$\overline{\text{RESET}}$	3	VBAT	4	XTAL1
14	P4[6]/A6	15	P4[21]/A21/ SCL2/SSEL1	16	P0[21]/R11/ MCIPWR/RD1	17	P0[20]/DTR1/ MCICMD/SCL1
<b>Row N</b>							
1	ALARM	2	P2[31]/DQMOUT3/ MAT3[3]/SCL2	3	P2[29]/DQMOUT1	4	XTAL2
14	P2[12]/ $\overline{\text{EINT2}}$ / MCIDAT2/I2STX_WS	15	P2[10]/ $\overline{\text{EINT0}}$	16	V <sub>SSIO</sub>	17	P0[22]/RTS1/ MCIDAT0/TD1
<b>Row P</b>							
1	P1[31]/ $\overline{\text{USB_OVRCR2}}$ / SCK1/AD0[5]	2	P1[30]/USB_PWRD2/ V <sub>BUS</sub> /AD0[4]	3	P2[27]/CKEOUT3/ MAT3[1]/MOSI0	4	P2[28]/DQMOUT0
5	P2[24]/CKEOUT0	6	V <sub>DD(3V3)</sub>	7	P1[18]/USB_UP_LED1/ PWM1[1]/CAP1[0]	8	V <sub>DD(3V3)</sub>
9	P1[23]/USB_RX_DP1/ PWM1[4]/MISO0	10	V <sub>SSCORE</sub>	11	V <sub>DD(DCDC)</sub> (3V3)	12	V <sub>SSIO</sub>
13	P2[15]/ $\overline{\text{CS3}}$ / CAP2[1]/SCL1	14	P4[17]/A17	15	P4[18]/A18	16	P4[19]/A19
17	V <sub>DD(3V3)</sub>	-	-	-	-	-	-
<b>Row R</b>							
1	P0[12]/ $\overline{\text{USB_PPWR2}}$ / MISO1/AD0[6]	2	P0[13]/USB_UP_LED2/ MOSI1/AD0[7]	3	P0[28]/SCL0	4	P2[25]/CKEOUT1
5	P3[24]/D24/ CAP0[1]/PWM1[1]	6	P0[30]/USB_D-1	7	P2[19]/CLKOUT1	8	P1[21]/USB_TX_DM1/ PWM1[3]/SSEL0
9	V <sub>SSIO</sub>	10	P1[26]/ $\overline{\text{USB_SSPND1}}$ / PWM1[6]/CAP0[0]	11	P2[16]/ $\overline{\text{CAS}}$	12	P2[14]/ $\overline{\text{CS2}}$ / CAP2[0]/SDA1

Table 3. Pin allocation table ...continued

Pin	Symbol	Pin	Symbol	Pin	Symbol	Pin	Symbol
13	P2[17]/RAS	14	P0[11]/RXD2/SCL2/ MAT3[1]	15	P4[4]/A4	16	P4[5]/A5
17	P4[20]/A20/ SDA2/SCK1	-	-	-	-	-	-
<b>Row T</b>							
1	P0[27]/SDA0	2	P0[31]/USB_D+2	3	P3[26]/D26/ MAT0[1]/PWM1[3]	4	P2[26]/CKEOUT2/ MAT3[0]/MISO0
5	V <sub>SSIO</sub>	6	P3[23]/D23/ CAP0[0]/PCAP1[0]	7	P0[14]/USB_HSTEN2/ USB_CONNECT2/ SSEL1	8	P2[20]/DYCS0
9	P1[24]/USB_RX_DM1/ PWM1[5]/MOSI0	10	P1[25]/USB_LS1/ USB_HSTEN1/MAT1[1]	11	P4[2]/A2	12	P1[27]/USB_INT1/ USB_OVRCR1/CAP0[1]
13	P1[28]/USB_SCL1/ PCAP1[0]/MAT0[0]	14	P0[1]/TD1/RXD3/SCL1	15	P0[10]/TXD2/SDA2/ MAT3[0]	16	P2[13]/EINT3/ MCIDAT3/I2STX_SDA
17	P2[11]/EINT1/ MCIDAT1/I2STX_CLK	-	-	-	-	-	-
<b>Row U</b>							
1	USB_D-2	2	P3[25]/D25/ MAT0[0]/PWM1[2]	3	P2[18]/CLKOUT0	4	P0[29]/USB_D+1
5	P2[23]/DYCS3/ CAP3[1]/SSEL0	6	P1[19]/USB_TX_E1/ USB_PPWR1/CAP1[1]	7	P1[20]/USB_TX_DP1/ PWM1[2]/SCK0	8	P1[22]/USB_RCV1/ USB_PWRD1/MAT1[0]
9	P4[0]/A0	10	P4[1]/A1	11	P2[21]/DYCS1	12	P2[22]/DYCS2/ CAP3[0]/SCK0
13	V <sub>DD(3V3)</sub>	14	P1[29]/USB_SDA1/ PCAP1[1]/MAT0[1]	15	P0[0]/RD1/TXD3/SDA1	16	P4[3]/A3
17	P4[16]/A16	-	-	-	-	-	-

## 6.2 Pin description

Table 4. Pin description

Symbol	Pin	Ball	Type	Description
P0[0] to P0[31]			I/O	<b>Port 0:</b> Port 0 is a 32-bit I/O port with individual direction controls for each bit. The operation of port 0 pins depends upon the pin function selected via the Pin Connect block.
P0[0]/RD1/ TXD3/SDA1	94 <sup>[1]</sup>	U15 <sup>[1]</sup>	I/O	<b>P0[0]</b> — General purpose digital input/output pin.
			I	<b>RD1</b> — CAN1 receiver input.
			O	<b>TXD3</b> — Transmitter output for UART3.
			I/O	<b>SDA1</b> — I <sup>2</sup> C1 data input/output (this is not an open-drain pin).
P0[1]/TD1/RXD3/ SCL1	96 <sup>[1]</sup>	T14 <sup>[1]</sup>	I/O	<b>P0[1]</b> — General purpose digital input/output pin.
			O	<b>TD1</b> — CAN1 transmitter output.
			I	<b>RXD3</b> — Receiver input for UART3.
			I/O	<b>SCL1</b> — I <sup>2</sup> C1 clock input/output (this is not an open-drain pin).
P0[2]/TXD0	202 <sup>[1]</sup>	C4 <sup>[1]</sup>	I/O	<b>P0[2]</b> — General purpose digital input/output pin.
			O	<b>TXD0</b> — Transmitter output for UART0.



Table 4. Pin description ...continued

Symbol	Pin	Ball	Type	Description
P0[3]/RXD0	204 <sup>[1]</sup>	D6 <sup>[1]</sup>	I/O	<b>P0[3]</b> — General purpose digital input/output pin.
			I	<b>RXD0</b> — Receiver input for UART0.
P0[4]/ I2SRX_CLK/ RD2/CAP2[0]	168 <sup>[1]</sup>	B12 <sup>[1]</sup>	I/O	<b>P0[4]</b> — General purpose digital input/output pin.
			I/O	<b>I2SRX_CLK</b> — Receive Clock. It is driven by the master and received by the slave. Corresponds to the signal SCK in the <i>I<sup>2</sup>S-bus specification</i> .
			I	<b>RD2</b> — CAN2 receiver input.
			I	<b>CAP2[0]</b> — Capture input for Timer 2, channel 0.
P0[5]/ I2SRX_WS/ TD2/CAP2[1]	166 <sup>[1]</sup>	C12 <sup>[1]</sup>	I/O	<b>P0[5]</b> — General purpose digital input/output pin.
			I/O	<b>I2SRX_WS</b> — Receive Word Select. It is driven by the master and received by the slave. Corresponds to the signal WS in the <i>I<sup>2</sup>S-bus specification</i> .
			O	<b>TD2</b> — CAN2 transmitter output.
			I	<b>CAP2[1]</b> — Capture input for Timer 2, channel 1.
P0[6]/ I2SRX_SDA/ SSEL1/MAT2[0]	164 <sup>[1]</sup>	D13 <sup>[1]</sup>	I/O	<b>P0[6]</b> — General purpose digital input/output pin.
			I/O	<b>I2SRX_SDA</b> — Receive data. It is driven by the transmitter and read by the receiver. Corresponds to the signal SD in the <i>I<sup>2</sup>S-bus specification</i> .
			I/O	<b>SSEL1</b> — Slave Select for SSP1.
			O	<b>MAT2[0]</b> — Match output for Timer 2, channel 0.
P0[7]/ I2STX_CLK/ SCK1/MAT2[1]	162 <sup>[1]</sup>	C13 <sup>[1]</sup>	I/O	<b>P0[7]</b> — General purpose digital input/output pin.
			I/O	<b>I2STX_CLK</b> — Transmit Clock. It is driven by the master and received by the slave. Corresponds to the signal SCK in the <i>I<sup>2</sup>S-bus specification</i> .
			I/O	<b>SCK1</b> — Serial Clock for SSP1.
			O	<b>MAT2[1]</b> — Match output for Timer 2, channel 1.
P0[8]/ I2STX_WS/ MISO1/MAT2[2]	160 <sup>[1]</sup>	A15 <sup>[1]</sup>	I/O	<b>P0[8]</b> — General purpose digital input/output pin.
			I/O	<b>I2STX_WS</b> — Transmit Word Select. It is driven by the master and received by the slave. Corresponds to the signal WS in the <i>I<sup>2</sup>S-bus specification</i> .
			I/O	<b>MISO1</b> — Master In Slave Out for SSP1.
			O	<b>MAT2[2]</b> — Match output for Timer 2, channel 2.
P0[9]/ I2STX_SDA/ MOSI1/MAT2[3]	158 <sup>[1]</sup>	C14 <sup>[1]</sup>	I/O	<b>P0[9]</b> — General purpose digital input/output pin.
			I/O	<b>I2STX_SDA</b> — Transmit data. It is driven by the transmitter and read by the receiver. Corresponds to the signal SD in the <i>I<sup>2</sup>S-bus specification</i> .
			I/O	<b>MOSI1</b> — Master Out Slave In for SSP1.
			O	<b>MAT2[3]</b> — Match output for Timer 2, channel 3.
P0[10]/TXD2/ SDA2/MAT3[0]	98 <sup>[1]</sup>	T15 <sup>[1]</sup>	I/O	<b>P0[10]</b> — General purpose digital input/output pin.
			O	<b>TXD2</b> — Transmitter output for UART2.
			I/O	<b>SDA2</b> — I <sup>2</sup> C2 data input/output (this is not an open-drain pin).
			O	<b>MAT3[0]</b> — Match output for Timer 3, channel 0.
P0[11]/RXD2/ SCL2/MAT3[1]	100 <sup>[1]</sup>	R14 <sup>[1]</sup>	I/O	<b>P0[11]</b> — General purpose digital input/output pin.
			I	<b>RXD2</b> — Receiver input for UART2.
			I/O	<b>SCL2</b> — I <sup>2</sup> C2 clock input/output (this is not an open-drain pin).
			O	<b>MAT3[1]</b> — Match output for Timer 3, channel 1.

Table 4. Pin description ...continued

Symbol	Pin	Ball	Type	Description
P0[12]/ USB_PPWR2/ MISO1/AD0[6]	41 <sup>[2]</sup>	R1 <sup>[2]</sup>	I/O	<b>P0[12]</b> — General purpose digital input/output pin.
			O	<b>USB_PPWR2</b> — Port Power enable signal for USB port 2.
			I/O	<b>MISO1</b> — Master In Slave Out for SSP1.
			I	<b>AD0[6]</b> — A/D converter 0, input 6.
P0[13]/ USB_UP_LED2/ MOSI1/AD0[7]	45 <sup>[2]</sup>	R2 <sup>[2]</sup>	I/O	<b>P0[13]</b> — General purpose digital input/output pin.
			O	<b>USB_UP_LED2</b> — USB port 2 GoodLink LED indicator. It is LOW when device is configured (non-control endpoints enabled). It is HIGH when the device is not configured or during global suspend.
			I/O	<b>MOSI1</b> — Master Out Slave In for SSP1.
			I	<b>AD0[7]</b> — A/D converter 0, input 7.
P0[14]/ USB_HSTEN2/ USB_CONNECT2/ SSEL1	69 <sup>[1]</sup>	T7 <sup>[1]</sup>	I/O	<b>P0[14]</b> — General purpose digital input/output pin.
			O	<b>USB_HSTEN2</b> — Host Enabled status for USB port 2.
			O	<b>USB_CONNECT2</b> — SoftConnect control for USB port 2. Signal used to switch an external 1.5 kΩ resistor under software control. Used with the SoftConnect USB feature.
			I/O	<b>SSEL1</b> — Slave Select for SSP1.
P0[15]/TXD1/ SCK0/SCK	128 <sup>[1]</sup>	J16 <sup>[1]</sup>	I/O	<b>P0[15]</b> — General purpose digital input/output pin.
			O	<b>TXD1</b> — Transmitter output for UART1.
			I/O	<b>SCK0</b> — Serial clock for SSP0.
			I/O	<b>SCK</b> — Serial clock for SPI.
P0[16]/RXD1/ SSEL0/SSEL	130 <sup>[1]</sup>	J14 <sup>[1]</sup>	I/O	<b>P0 [16]</b> — General purpose digital input/output pin.
			I	<b>RXD1</b> — Receiver input for UART1.
			I/O	<b>SSEL0</b> — Slave Select for SSP0.
			I/O	<b>SSEL</b> — Slave Select for SPI.
P0[17]/CTS1/ MISO0/MISO	126 <sup>[1]</sup>	K17 <sup>[1]</sup>	I/O	<b>P0[17]</b> — General purpose digital input/output pin.
			I	<b>CTS1</b> — Clear to Send input for UART1.
			I/O	<b>MISO0</b> — Master In Slave Out for SSP0.
			I/O	<b>MISO</b> — Master In Slave Out for SPI.
P0[18]/DCD1/ MOSI0/MOSI	124 <sup>[1]</sup>	K15 <sup>[1]</sup>	I/O	<b>P0[18]</b> — General purpose digital input/output pin.
			I	<b>DCD1</b> — Data Carrier Detect input for UART1.
			I/O	<b>MOSI0</b> — Master Out Slave In for SSP0.
			I/O	<b>MOSI</b> — Master Out Slave In for SPI.
P0[19]/DSR1/ MCICLK/SDA1	122 <sup>[1]</sup>	L17 <sup>[1]</sup>	I/O	<b>P0[19]</b> — General purpose digital input/output pin.
			I	<b>DSR1</b> — Data Set Ready input for UART1.
			O	<b>MCICLK</b> — Clock output line for SD/MMC interface.
			I/O	<b>SDA1</b> — I <sup>2</sup> C1 data input/output (this is not an open-drain pin).
P0[20]/DTR1/ MCICMD/SCL1	120 <sup>[1]</sup>	M17 <sup>[1]</sup>	I/O	<b>P0[20]</b> — General purpose digital input/output pin.
			O	<b>DTR1</b> — Data Terminal Ready output for UART1.
			I/O	<b>MCICMD</b> — Command line for SD/MMC interface.
			I/O	<b>SCL1</b> — I <sup>2</sup> C1 clock input/output (this is not an open-drain pin).

Table 4. Pin description ...continued

Symbol	Pin	Ball	Type	Description
P0[21]/R11/ MCIPWR/RD1	118 <sup>[1]</sup>	M16 <sup>[1]</sup>	I/O	<b>P0[21]</b> — General purpose digital input/output pin.
			I	<b>R11</b> — Ring Indicator input for UART1.
			O	<b>MCIPWR</b> — Power Supply Enable for external SD/MMC power supply.
			I	<b>RD1</b> — CAN1 receiver input.
P0[22]/RTS1/ MCIDAT0/TD1	116 <sup>[1]</sup>	N17 <sup>[1]</sup>	I/O	<b>P0[22]</b> — General purpose digital input/output pin.
			O	<b>RTS1</b> — Request to Send output for UART1.
			I/O	<b>MCIDAT0</b> — Data line 0 for SD/MMC interface.
			O	<b>TD1</b> — CAN1 transmitter output.
P0[23]/AD0[0]/ I2SRX_CLK/ CAP3[0]	18 <sup>[2]</sup>	H1 <sup>[2]</sup>	I/O	<b>P0[23]</b> — General purpose digital input/output pin.
			I	<b>AD0[0]</b> — A/D converter 0, input 0.
			I/O	<b>I2SRX_CLK</b> — Receive Clock. It is driven by the master and received by the slave. Corresponds to the signal SCK in the <i>I<sup>2</sup>S-bus specification</i> .
			I	<b>CAP3[0]</b> — Capture input for Timer 3, channel 0.
P0[24]/AD0[1]/ I2SRX_WS/ CAP3[1]	16 <sup>[2]</sup>	G2 <sup>[2]</sup>	I/O	<b>P0[24]</b> — General purpose digital input/output pin.
			I	<b>AD0[1]</b> — A/D converter 0, input 1.
			I/O	<b>I2SRX_WS</b> — Receive Word Select. It is driven by the master and received by the slave. Corresponds to the signal WS in the <i>I<sup>2</sup>S-bus specification</i> .
			I	<b>CAP3[1]</b> — Capture input for Timer 3, channel 1.
P0[25]/AD0[2]/ I2SRX_SDA/ TXD3	14 <sup>[2]</sup>	F1 <sup>[2]</sup>	I/O	<b>P0[25]</b> — General purpose digital input/output pin.
			I	<b>AD0[2]</b> — A/D converter 0, input 2.
			I/O	<b>I2SRX_SDA</b> — Receive data. It is driven by the transmitter and read by the receiver. Corresponds to the signal SD in the <i>I<sup>2</sup>S-bus specification</i> .
			O	<b>TXD3</b> — Transmitter output for UART3.
P0[26]/AD0[3]/ AOUT/RXD3	12 <sup>[2][3]</sup>	E1 <sup>[2][3]</sup>	I/O	<b>P0[26]</b> — General purpose digital input/output pin.
			I	<b>AD0[3]</b> — A/D converter 0, input 3.
			O	<b>AOUT</b> — D/A converter output.
			I	<b>RXD3</b> — Receiver input for UART3.
P0[27]/SDA0	50 <sup>[4]</sup>	T1 <sup>[4]</sup>	I/O	<b>P0[27]</b> — General purpose digital input/output pin.
			I/O	<b>SDA0</b> — I <sup>2</sup> C0 data input/output. Open-drain output (for I <sup>2</sup> C-bus compliance).
P0[28]/SCL0	48 <sup>[4]</sup>	R3 <sup>[4]</sup>	I/O	<b>P0[28]</b> — General purpose digital input/output pin.
			I/O	<b>SCL0</b> — I <sup>2</sup> C0 clock input/output. Open-drain output (for I <sup>2</sup> C-bus compliance).
P0[29]/USB_D+1	61 <sup>[5]</sup>	U4 <sup>[5]</sup>	I/O	<b>P0[29]</b> — General purpose digital input/output pin.
			I/O	<b>USB_D+1</b> — USB port 1 bidirectional D+ line.
P0[30]/USB_D-1	62 <sup>[5]</sup>	R6 <sup>[5]</sup>	I/O	<b>P0[30]</b> — General purpose digital input/output pin.
			I/O	<b>USB_D-1</b> — USB port 1 bidirectional D- line.
P0[31]/USB_D+2	51 <sup>[5]</sup>	T2 <sup>[5]</sup>	I/O	<b>P0[31]</b> — General purpose digital input/output pin.
			I/O	<b>USB_D+2</b> — USB port 2 bidirectional D+ line.
P1[0] to P1[31]			I/O	<b>Port 1:</b> Port 1 is a 32 bit I/O port with individual direction controls for each bit. The operation of port 1 pins depends upon the pin function selected via the Pin Connect block.

Table 4. Pin description ...continued

Symbol	Pin	Ball	Type	Description
P1[0]/ ENET_TXD0	196 <sup>[1]</sup>	A3 <sup>[1]</sup>	I/O	<b>P1[0]</b> — General purpose digital input/output pin.
			O	<b>ENET_TXD0</b> — Ethernet transmit data 0 (RMII/MII interface).
P1[1]/ ENET_TXD1	194 <sup>[1]</sup>	B5 <sup>[1]</sup>	I/O	<b>P1[1]</b> — General purpose digital input/output pin.
			O	<b>ENET_TXD1</b> — Ethernet transmit data 1 (RMII/MII interface).
P1[2]/ ENET_TXD2/ MCICLK/ PWM0[1]	185 <sup>[1]</sup>	D9 <sup>[1]</sup>	I/O	<b>P1[2]</b> — General purpose digital input/output pin.
			O	<b>ENET_TXD2</b> — Ethernet transmit data 2 (MII interface).
			O	<b>MCICLK</b> — Clock output line for SD/MMC interface.
			O	<b>PWM0[1]</b> — Pulse Width Modulator 0, output 1.
P1[3]/ ENET_TXD3/ MCICMD/ PWM0[2]	177 <sup>[1]</sup>	A10 <sup>[1]</sup>	I/O	<b>P1[3]</b> — General purpose digital input/output pin.
			O	<b>ENET_TXD3</b> — Ethernet transmit data 3 (MII interface).
			I/O	<b>MCICMD</b> — Command line for SD/MMC interface.
			O	<b>PWM0[2]</b> — Pulse Width Modulator 0, output 2.
P1[4]/ ENET_TX_EN	192 <sup>[1]</sup>	A5 <sup>[1]</sup>	I/O	<b>P1[4]</b> — General purpose digital input/output pin.
			O	<b>ENET_TX_EN</b> — Ethernet transmit data enable (RMII/MII interface).
P1[5]/ ENET_TX_ER/ MCIPWR/ PWM0[3]	156 <sup>[1]</sup>	A17 <sup>[1]</sup>	I/O	<b>P1[5]</b> — General purpose digital input/output pin.
			O	<b>ENET_TX_ER</b> — Ethernet Transmit Error (MII interface).
			O	<b>MCIPWR</b> — Power Supply Enable for external SD/MMC power supply.
			O	<b>PWM0[3]</b> — Pulse Width Modulator 0, output 3.
P1[6]/ ENET_TX_CLK/ MCIDAT0/ PWM0[4]	171 <sup>[1]</sup>	B11 <sup>[1]</sup>	I/O	<b>P1[6]</b> — General purpose digital input/output pin.
			I	<b>ENET_TX_CLK</b> — Ethernet Transmit Clock (MII interface).
			I/O	<b>MCIDAT0</b> — Data line 0 for SD/MMC interface.
			O	<b>PWM0[4]</b> — Pulse Width Modulator 0, output 4.
P1[7]/ ENET_COL/ MCIDAT1/ PWM0[5]	153 <sup>[1]</sup>	D14 <sup>[1]</sup>	I/O	<b>P1[7]</b> — General purpose digital input/output pin.
			I	<b>ENET_COL</b> — Ethernet Collision detect (MII interface).
			I/O	<b>MCIDAT1</b> — Data line 1 for SD/MMC interface.
			O	<b>PWM0[5]</b> — Pulse Width Modulator 0, output 5.
P1[8]/ ENET_CRS_DV/ ENET_CRS	190 <sup>[1]</sup>	C7 <sup>[1]</sup>	I/O	<b>P1[8]</b> — General purpose digital input/output pin.
			I	<b>ENET_CRS_DV/ENET_CRS</b> — Ethernet Carrier Sense/Data Valid (RMII interface)/ Ethernet Carrier Sense (MII interface).
P1[9]/ ENET_RXD0	188 <sup>[1]</sup>	A6 <sup>[1]</sup>	I/O	<b>P1[9]</b> — General purpose digital input/output pin.
			I	<b>ENET_RXD0</b> — Ethernet receive data 0 (RMII/MII interface).
P1[10]/ ENET_RXD1	186 <sup>[1]</sup>	C8 <sup>[1]</sup>	I/O	<b>P1[10]</b> — General purpose digital input/output pin.
			I	<b>ENET_RXD1</b> — Ethernet receive data 1 (RMII/MII interface).
P1[11]/ ENET_RXD2/ MCIDAT2/ PWM0[6]	163 <sup>[1]</sup>	A14 <sup>[1]</sup>	I/O	<b>P1[11]</b> — General purpose digital input/output pin.
			I	<b>ENET_RXD2</b> — Ethernet Receive Data 2 (MII interface).
			I/O	<b>MCIDAT2</b> — Data line 2 for SD/MMC interface.
			O	<b>PWM0[6]</b> — Pulse Width Modulator 0, output 6.
P1[12]/ ENET_RXD3/ MCIDAT3/ PCAP0[0]	157 <sup>[1]</sup>	A16 <sup>[1]</sup>	I/O	<b>P1[12]</b> — General purpose digital input/output pin.
			I	<b>ENET_RXD3</b> — Ethernet Receive Data (MII interface).
			I/O	<b>MCIDAT3</b> — Data line 3 for SD/MMC interface.
			I	<b>PCAP0[0]</b> — Capture input for PWM0, channel 0.

Table 4. Pin description ...continued

Symbol	Pin	Ball	Type	Description
P1[13]/ ENET_RX_DV	147 <sup>[1]</sup>	D16 <sup>[1]</sup>	I/O	<b>P1[13]</b> — General purpose digital input/output pin.
			I	<b>ENET_RX_DV</b> — Ethernet Receive Data Valid (MII interface).
P1[14]/ ENET_RX_ER	184 <sup>[1]</sup>	A7 <sup>[1]</sup>	I/O	<b>P1[14]</b> — General purpose digital input/output pin.
			I	<b>ENET_RX_ER</b> — Ethernet receive error (RMII/MII interface).
P1[15]/ ENET_REF_CLK/ ENET_RX_CLK	182 <sup>[1]</sup>	A8 <sup>[1]</sup>	I/O	<b>P1[15]</b> — General purpose digital input/output pin.
			I	<b>ENET_REF_CLK/ENET_RX_CLK</b> — Ethernet Reference Clock (RMII interface)/ Ethernet Receive Clock (MII interface).
P1[16]/ ENET_MDC	180 <sup>[1]</sup>	D10 <sup>[1]</sup>	I/O	<b>P1[16]</b> — General purpose digital input/output pin.
			O	<b>ENET_MDC</b> — Ethernet MIIM clock.
P1[17]/ ENET_MDIO	178 <sup>[1]</sup>	A9 <sup>[1]</sup>	I/O	<b>P1[17]</b> — General purpose digital input/output pin.
			I/O	<b>ENET_MDIO</b> — Ethernet MI data input and output.
P1[18]/ USB_UP_LED1/ PWM1[1]/ CAP1[0]	66 <sup>[1]</sup>	P7 <sup>[1]</sup>	I/O	<b>P1[18]</b> — General purpose digital input/output pin.
			O	<b>USB_UP_LED1</b> — USB port 1 GoodLink LED indicator. It is LOW when device is configured (non-control endpoints enabled). It is HIGH when the device is not configured or during global suspend.
			O	<b>PWM1[1]</b> — Pulse Width Modulator 1, channel 1 output.
			I	<b>CAP1[0]</b> — Capture input for Timer 1, channel 0.
P1[19]/ USB_TX_E1/ USB_PPWR1/ CAP1[1]	68 <sup>[1]</sup>	U6 <sup>[1]</sup>	I/O	<b>P1[19]</b> — General purpose digital input/output pin.
			O	<b>USB_TX_E1</b> — Transmit Enable signal for USB port 1 (OTG transceiver).
			O	<b>USB_PPWR1</b> — Port Power enable signal for USB port 1.
			I	<b>CAP1[1]</b> — Capture input for Timer 1, channel 1.
P1[20]/ USB_TX_DP1/ PWM1[2]/SCK0	70 <sup>[1]</sup>	U7 <sup>[1]</sup>	I/O	<b>P1[20]</b> — General purpose digital input/output pin.
			O	<b>USB_TX_DP1</b> — D+ transmit data for USB port 1 (OTG transceiver).
			O	<b>PWM1[2]</b> — Pulse Width Modulator 1, channel 2 output.
			I/O	<b>SCK0</b> — Serial clock for SSP0.
P1[21]/ USB_TX_DM1/ PWM1[3]/SSEL0	72 <sup>[1]</sup>	R8 <sup>[1]</sup>	I/O	<b>P1[21]</b> — General purpose digital input/output pin.
			O	<b>USB_TX_DM1</b> — D– transmit data for USB port 1 (OTG transceiver).
			O	<b>PWM1[3]</b> — Pulse Width Modulator 1, channel 3 output.
			I/O	<b>SSEL0</b> — Slave Select for SSP0.
P1[22]/ USB_RCV1/ USB_PWRD1/ MAT1[0]	74 <sup>[1]</sup>	U8 <sup>[1]</sup>	I/O	<b>P1[22]</b> — General purpose digital input/output pin.
			I	<b>USB_RCV1</b> — Differential receive data for USB port 1 (OTG transceiver).
			I	<b>USB_PWRD1</b> — Power Status for USB port 1 (host power switch).
			O	<b>MAT1[0]</b> — Match output for Timer 1, channel 0.
P1[23]/ USB_RX_DP1/ PWM1[4]/MISO0	76 <sup>[1]</sup>	P9 <sup>[1]</sup>	I/O	<b>P1[23]</b> — General purpose digital input/output pin.
			I	<b>USB_RX_DP1</b> — D+ receive data for USB port 1 (OTG transceiver).
			O	<b>PWM1[4]</b> — Pulse Width Modulator 1, channel 4 output.
			I/O	<b>MISO0</b> — Master In Slave Out for SSP0.
P1[24]/ USB_RX_DM1/ PWM1[5]/MOSI0	78 <sup>[1]</sup>	T9 <sup>[1]</sup>	I/O	<b>P1[24]</b> — General purpose digital input/output pin.
			I	<b>USB_RX_DM1</b> — D– receive data for USB port 1 (OTG transceiver).
			O	<b>PWM1[5]</b> — Pulse Width Modulator 1, channel 5 output.
			I/O	<b>MOSI0</b> — Master Out Slave in for SSP0.

Table 4. Pin description ...continued

Symbol	Pin	Ball	Type	Description
P1[25]/ USB_LS1/ USB_HSTEN1/ MAT1[1]	80 <sup>[1]</sup>	T10 <sup>[1]</sup>	I/O	<b>P1[25]</b> — General purpose digital input/output pin.
			O	<b>USB_LS1</b> — Low-speed status for USB port 1 (OTG transceiver).
			O	<b>USB_HSTEN1</b> — Host Enabled status for USB port 1.
			O	<b>MAT1[1]</b> — Match output for Timer 1, channel 1.
P1[26]/ USB_SSPND1/ PWM1[6]/ CAP0[0]	82 <sup>[1]</sup>	R10 <sup>[1]</sup>	I/O	<b>P1[26]</b> — General purpose digital input/output pin.
			O	<b>USB_SSPND1</b> — USB port 1 Bus Suspend status (OTG transceiver).
			O	<b>PWM1[6]</b> — Pulse Width Modulator 1, channel 6 output.
			I	<b>CAP0[0]</b> — Capture input for Timer 0, channel 0.
P1[27]/ USB_INT1/ USB_OVRCR1/ CAP0[1]	88 <sup>[1]</sup>	T12 <sup>[1]</sup>	I/O	<b>P1[27]</b> — General purpose digital input/output pin.
			I	<b>USB_INT1</b> — USB port 1 OTG transceiver interrupt (OTG transceiver).
			I	<b>USB_OVRCR1</b> — USB port 1 Over-Current status.
			I	<b>CAP0[1]</b> — Capture input for Timer 0, channel 1.
P1[28]/ USB_SCL1/ PCAP1[0]/ MAT0[0]	90 <sup>[1]</sup>	T13 <sup>[1]</sup>	I/O	<b>P1[28]</b> — General purpose digital input/output pin.
			I/O	<b>USB_SCL1</b> — USB port 1 I <sup>2</sup> C serial clock (OTG transceiver).
			I	<b>PCAP1[0]</b> — Capture input for PWM1, channel 0.
			O	<b>MAT0[0]</b> — Match output for Timer 0, channel 0.
P1[29]/ USB_SDA1/ PCAP1[1]/ MAT0[1]	92 <sup>[1]</sup>	U14 <sup>[1]</sup>	I/O	<b>P1[29]</b> — General purpose digital input/output pin.
			I/O	<b>USB_SDA1</b> — USB port 1 I <sup>2</sup> C serial data (OTG transceiver).
			I	<b>PCAP1[1]</b> — Capture input for PWM1, channel 1.
			O	<b>MAT0[1]</b> — Match output for Timer 0, channel 0.
P1[30]/ USB_PWRD2/ V <sub>BUS</sub> /AD0[4]	42 <sup>[2]</sup>	P2 <sup>[2]</sup>	I/O	<b>P1[30]</b> — General purpose digital input/output pin.
			I	<b>USB_PWRD2</b> — Power Status for USB port 2.
			I	<b>V<sub>BUS</sub></b> — Monitors the presence of USB bus power. <b>Note:</b> This signal must be HIGH for USB reset to occur.
			I	<b>AD0[4]</b> — A/D converter 0, input 4.
P1[31]/ USB_OVRCR2/ SCK1/AD0[5]	40 <sup>[2]</sup>	P1 <sup>[2]</sup>	I/O	<b>P1[31]</b> — General purpose digital input/output pin.
			I	<b>USB_OVRCR2</b> — Over-Current status for USB port 2.
			I/O	<b>SCK1</b> — Serial Clock for SSP1.
			I	<b>AD0[5]</b> — A/D converter 0, input 5.
P2[0] to P2[31]			I/O	<b>Port 2:</b> Port 2 is a 32-bit I/O port with individual direction controls for each bit. The operation of port 2 pins depends upon the pin function selected via the Pin Connect block.
P2[0]/PWM1[1]/ TXD1/ TRACECLK	154 <sup>[1]</sup>	B17 <sup>[1]</sup>	I/O	<b>P2[0]</b> — General purpose digital input/output pin.
			O	<b>PWM1[1]</b> — Pulse Width Modulator 1, channel 1 output.
			O	<b>TXD1</b> — Transmitter output for UART1.
			O	<b>TRACECLK</b> — Trace Clock.
P2[1]/PWM1[2]/ RXD1/ PIPESTAT0	152 <sup>[1]</sup>	E14 <sup>[1]</sup>	I/O	<b>P2[1]</b> — General purpose digital input/output pin.
			O	<b>PWM1[2]</b> — Pulse Width Modulator 1, channel 2 output.
			I	<b>RXD1</b> — Receiver input for UART1.
			O	<b>PIPESTAT0</b> — Pipeline Status, bit 0.

Table 4. Pin description ...continued

Symbol	Pin	Ball	Type	Description
P2[2]/PWM1[3]/ CTS1/ PIPESTAT1	150 <sup>[1]</sup>	D15 <sup>[1]</sup>	I/O	<b>P2[2]</b> — General purpose digital input/output pin.
			O	<b>PWM1[3]</b> — Pulse Width Modulator 1, channel 3 output.
			I	<b>CTS1</b> — Clear to Send input for UART1.
			O	<b>PIPESTAT1</b> — Pipeline Status, bit 1.
P2[3]/PWM1[4]/ DCD1/ PIPESTAT2	144 <sup>[1]</sup>	E16 <sup>[1]</sup>	I/O	<b>P2[3]</b> — General purpose digital input/output pin.
			O	<b>PWM1[4]</b> — Pulse Width Modulator 1, channel 4 output.
			I	<b>DCD1</b> — Data Carrier Detect input for UART1.
			O	<b>PIPESTAT2</b> — Pipeline Status, bit 2.
P2[4]/PWM1[5]/ DSR1/ TRACESYNC	142 <sup>[1]</sup>	D17 <sup>[1]</sup>	I/O	<b>P2[4]</b> — General purpose digital input/output pin.
			O	<b>PWM1[5]</b> — Pulse Width Modulator 1, channel 5 output.
			I	<b>DSR1</b> — Data Set Ready input for UART1.
			O	<b>TRACESYNC</b> — Trace Synchronization.
P2[5]/PWM1[6]/ DTR1/ TRACEPKT0	140 <sup>[1]</sup>	F16 <sup>[1]</sup>	I/O	<b>P2[5]</b> — General purpose digital input/output pin.
			O	<b>PWM1[6]</b> — Pulse Width Modulator 1, channel 6 output.
			O	<b>DTR1</b> — Data Terminal Ready output for UART1.
			O	<b>TRACEPKT0</b> — Trace Packet, bit 0.
P2[6]/PCAP1[0]/ RI1/TRACEPKT1	138 <sup>[1]</sup>	E17 <sup>[1]</sup>	I/O	<b>P2[6]</b> — General purpose digital input/output pin.
			I	<b>PCAP1[0]</b> — Capture input for PWM1, channel 0.
			I	<b>RI1</b> — Ring Indicator input for UART1.
			O	<b>TRACEPKT1</b> — Trace Packet, bit 1.
P2[7]/RD2/ RTS1/ TRACEPKT2	136 <sup>[1]</sup>	G16 <sup>[1]</sup>	I/O	<b>P2[7]</b> — General purpose digital input/output pin.
			I	<b>RD2</b> — CAN2 receiver input.
			O	<b>RTS1</b> — Request to Send output for UART1.
			O	<b>TRACEPKT2</b> — Trace Packet, bit 2.
P2[8]/TD2/ TXD2/ TRACEPKT3	134 <sup>[1]</sup>	H15 <sup>[1]</sup>	I/O	<b>P2[8]</b> — General purpose digital input/output pin.
			O	<b>TD2</b> — CAN2 transmitter output.
			O	<b>TXD2</b> — Transmitter output for UART2.
			O	<b>TRACEPKT3</b> — Trace Packet, bit 3.
P2[9]/ USB_CONNECT1/ RXD2/ EXTIN0	132 <sup>[1]</sup>	H16 <sup>[1]</sup>	I/O	<b>P2[9]</b> — General purpose digital input/output pin.
			O	<b>USB_CONNECT1</b> — USB1 SoftConnect control. Signal used to switch an external 1.5 kΩ resistor under the software control. Used with the SoftConnect USB feature.
			I	<b>RXD2</b> — Receiver input for UART2.
			I	<b>EXTIN0</b> — External Trigger Input.
P2[10]/EINT0	110 <sup>[6]</sup>	N15 <sup>[6]</sup>	I/O	<b>P2[10]</b> — General purpose digital input/output pin. <b>Note:</b> LOW on this pin while RESET is LOW forces on-chip bootloader to take over control of the part after a reset.
			I	<b>EINT0</b> — External interrupt 0 input.

Table 4. Pin description ...continued

Symbol	Pin	Ball	Type	Description
P2[11]/EINT1/ MCIDAT1/ I2STX_CLK	108 <sup>[6]</sup>	T17 <sup>[6]</sup>	I/O	<b>P2[11]</b> — General purpose digital input/output pin.
			I	<b>EINT1</b> — External interrupt 1 input.
			I/O	<b>MCIDAT1</b> — Data line 1 for SD/MMC interface.
			I/O	<b>I2STX_CLK</b> — Transmit Clock. It is driven by the master and received by the slave. Corresponds to the signal SCK in the <i>I<sup>2</sup>S-bus specification</i> .
P2[12]/EINT2/ MCIDAT2/ I2STX_WS	106 <sup>[6]</sup>	N14 <sup>[6]</sup>	I/O	<b>P2[12]</b> — General purpose digital input/output pin.
			I	<b>EINT2</b> — External interrupt 2 input.
			I/O	<b>MCIDAT2</b> — Data line 2 for SD/MMC interface.
			I/O	<b>I2STX_WS</b> — Transmit Word Select. It is driven by the master and received by the slave. Corresponds to the signal WS in the <i>I<sup>2</sup>S-bus specification</i> .
P2[13]/EINT3/ MCIDAT3/ I2STX_SDA	102 <sup>[6]</sup>	T16 <sup>[6]</sup>	I/O	<b>P2[13]</b> — General purpose digital input/output pin.
			I	<b>EINT3</b> — External interrupt 3 input.
			I/O	<b>MCIDAT3</b> — Data line 3 for SD/MMC interface.
			I/O	<b>I2STX_SDA</b> — Transmit data. It is driven by the transmitter and read by the receiver. Corresponds to the signal SD in the <i>I<sup>2</sup>S-bus specification</i> .
P2[14]/CS2/ CAP2[0]/SDA1	91 <sup>[6]</sup>	R12 <sup>[6]</sup>	I/O	<b>P2[14]</b> — General purpose digital input/output pin.
			O	<b>CS2</b> — LOW active Chip Select 2 signal.
			I	<b>CAP2[0]</b> — Capture input for Timer 2, channel 0.
			I/O	<b>SDA1</b> — I <sup>2</sup> C1 data input/output (this is not an open-drain pin).
P2[15]/CS3/ CAP2[1]/SCL1	99 <sup>[6]</sup>	P13 <sup>[6]</sup>	I/O	<b>P2[15]</b> — General purpose digital input/output pin.
			O	<b>CS3</b> — LOW active Chip Select 3 signal.
			I	<b>CAP2[1]</b> — Capture input for Timer 2, channel 1.
			I/O	<b>SCL1</b> — I <sup>2</sup> C1 clock input/output (this is not an open-drain pin).
P2[16]/CAS	87 <sup>[1]</sup>	R11 <sup>[1]</sup>	I/O	<b>P2[16]</b> — General purpose digital input/output pin.
			O	<b>CAS</b> — LOW active SDRAM Column Address Strobe.
P2[17]/RAS	95 <sup>[1]</sup>	R13 <sup>[1]</sup>	I/O	<b>P2[17]</b> — General purpose digital input/output pin.
			O	<b>RAS</b> — LOW active SDRAM Row Address Strobe.
P2[18]/ CLKOUT0	59 <sup>[1]</sup>	U3 <sup>[1]</sup>	I/O	<b>P2[18]</b> — General purpose digital input/output pin.
			O	<b>CLKOUT0</b> — SDRAM clock 0.
P2[19]/ CLKOUT1	67 <sup>[1]</sup>	R7 <sup>[1]</sup>	I/O	<b>P2[19]</b> — General purpose digital input/output pin.
			O	<b>CLKOUT1</b> — SDRAM clock 1.
P2[20]/DYCS0	73 <sup>[1]</sup>	T8 <sup>[1]</sup>	I/O	<b>P2[20]</b> — General purpose digital input/output pin.
			O	<b>DYCS0</b> — SDRAM chip select 0.
P2[21]/DYCS1	81 <sup>[1]</sup>	U11 <sup>[1]</sup>	I/O	<b>P2[21]</b> — General purpose digital input/output pin.
			O	<b>DYCS1</b> — SDRAM chip select 1.
P2[22]/DYCS2/ CAP3[0]/SCK0	85 <sup>[1]</sup>	U12 <sup>[1]</sup>	I/O	<b>P2[22]</b> — General purpose digital input/output pin.
			O	<b>DYCS2</b> — SDRAM chip select 2.
			I	<b>CAP3[0]</b> — Capture input for Timer 3, channel 0.
			I/O	<b>SCK0</b> — Serial clock for SSP0.



Table 4. Pin description ...continued

Symbol	Pin	Ball	Type	Description
P2[23]/DYCS3/ CAP3[1]/SSEL0	64 <sup>[1]</sup>	U5 <sup>[1]</sup>	I/O	<b>P2[23]</b> — General purpose digital input/output pin.
			O	<b>DYCS3</b> — SDRAM chip select 3.
			I	<b>CAP3[1]</b> — Capture input for Timer 3, channel 1.
			I/O	<b>SSEL0</b> — Slave Select for SSP0.
P2[24]/ CKEOUT0	53 <sup>[1]</sup>	P5 <sup>[1]</sup>	I/O	<b>P2[24]</b> — General purpose digital input/output pin.
			O	<b>CKEOUT0</b> — SDRAM clock enable 0.
P2[25]/ CKEOUT1	54 <sup>[1]</sup>	R4 <sup>[1]</sup>	I/O	<b>P2[25]</b> — General purpose digital input/output pin.
			O	<b>CKEOUT1</b> — SDRAM clock enable 1.
P2[26]/ CKEOUT2/ MAT3[0]/MISO0	57 <sup>[1]</sup>	T4 <sup>[1]</sup>	I/O	<b>P2[26]</b> — General purpose digital input/output pin.
			O	<b>CKEOUT2</b> — SDRAM clock enable 2.
			O	<b>MAT3[0]</b> — Match output for Timer 3, channel 0.
			I/O	<b>MISO0</b> — Master In Slave Out for SSP0.
P2[27]/ CKEOUT3/ MAT3[1]/MOSI0	47 <sup>[1]</sup>	P3 <sup>[1]</sup>	I/O	<b>P2[27]</b> — General purpose digital input/output pin.
			O	<b>CKEOUT3</b> — SDRAM clock enable 3.
			O	<b>MAT3[1]</b> — Match output for Timer 3, channel 1.
			I/O	<b>MOSI0</b> — Master Out Slave In for SSP0.
P2[28]/ DQMOUT0	49 <sup>[1]</sup>	P4 <sup>[1]</sup>	I/O	<b>P2[28]</b> — General purpose digital input/output pin.
			O	<b>DQMOUT0</b> — Data mask 0 used with SDRAM and static devices.
P2[29]/ DQMOUT1	43 <sup>[1]</sup>	N3 <sup>[1]</sup>	I/O	<b>P2[29]</b> — General purpose digital input/output pin.
			O	<b>DQMOUT1</b> — Data mask 1 used with SDRAM and static devices.
P2[30]/ DQMOUT2/ MAT3[2]/SDA2	31 <sup>[1]</sup>	L4 <sup>[1]</sup>	I/O	<b>P2[30]</b> — General purpose digital input/output pin.
			O	<b>DQMOUT2</b> — Data mask 2 used with SDRAM and static devices.
			O	<b>MAT3[2]</b> — Match output for Timer 3, channel 2.
			I/O	<b>SDA2</b> — I <sup>2</sup> C2 data input/output (this is not an open-drain pin).
P2[31]/ DQMOUT3/ MAT3[3]/SCL2	39 <sup>[1]</sup>	N2 <sup>[1]</sup>	I/O	<b>P2[31]</b> — General purpose digital input/output pin.
			O	<b>DQMOUT3</b> — Data mask 3 used with SDRAM and static devices.
			O	<b>MAT3[3]</b> — Match output for Timer 3, channel 3.
			I/O	<b>SCL2</b> — I <sup>2</sup> C2 clock input/output (this is not an open-drain pin).
P3[0] to P3[31]			I/O	<b>Port 3:</b> Port 3 is a 32-bit I/O port with individual direction controls for each bit. The operation of port 3 pins depends upon the pin function selected via the Pin Connect block.
P3[0]/D0	197 <sup>[1]</sup>	B4 <sup>[1]</sup>	I/O	<b>P3[0]</b> — General purpose digital input/output pin.
			I/O	<b>D0</b> — External memory data line 0.
P3[1]/D1	201 <sup>[1]</sup>	B3 <sup>[1]</sup>	I/O	<b>P3[1]</b> — General purpose digital input/output pin.
			I/O	<b>D1</b> — External memory data line 1.
P3[2]/D2	207 <sup>[1]</sup>	B1 <sup>[1]</sup>	I/O	<b>P3[2]</b> — General purpose digital input/output pin.
			I/O	<b>D2</b> — External memory data line 2.
P3[3]/D3	3 <sup>[1]</sup>	E4 <sup>[1]</sup>	I/O	<b>P3[3]</b> — General purpose digital input/output pin.
			I/O	<b>D3</b> — External memory data line 3.
P3[4]/D4	13 <sup>[1]</sup>	F2 <sup>[1]</sup>	I/O	<b>P3[4]</b> — General purpose digital input/output pin.
			I/O	<b>D4</b> — External memory data line 4.

Table 4. Pin description ...continued

Symbol	Pin	Ball	Type	Description
P3[5]/D5	17 <sup>[1]</sup>	G1 <sup>[1]</sup>	I/O	<b>P3[5]</b> — General purpose digital input/output pin.
			I/O	<b>D5</b> — External memory data line 5.
P3[6]/D6	23 <sup>[1]</sup>	J1 <sup>[1]</sup>	I/O	<b>P3[6]</b> — General purpose digital input/output pin.
			I/O	<b>D6</b> — External memory data line 6.
P3[7]/D7	27 <sup>[1]</sup>	L1 <sup>[1]</sup>	I/O	<b>P3[7]</b> — General purpose digital input/output pin.
			I/O	<b>D7</b> — External memory data line 7.
P3[8]/D8	191 <sup>[1]</sup>	D8 <sup>[1]</sup>	I/O	<b>P3[8]</b> — General purpose digital input/output pin.
			I/O	<b>D8</b> — External memory data line 8.
P3[9]/D9	199 <sup>[1]</sup>	C5 <sup>[1]</sup>	I/O	<b>P3[9]</b> — General purpose digital input/output pin.
			I/O	<b>D9</b> — External memory data line 9.
P3[10]/D10	205 <sup>[1]</sup>	B2 <sup>[1]</sup>	I/O	<b>P3[10]</b> — General purpose digital input/output pin.
			I/O	<b>D10</b> — External memory data line 10.
P3[11]/D11	208 <sup>[1]</sup>	D5 <sup>[1]</sup>	I/O	<b>P3[11]</b> — General purpose digital input/output pin.
			I/O	<b>D11</b> — External memory data line 11.
P3[12]/D12	1 <sup>[1]</sup>	D4 <sup>[1]</sup>	I/O	<b>P3[12]</b> — General purpose digital input/output pin.
			I/O	<b>D12</b> — External memory data line 12.
P3[13]/D13	7 <sup>[1]</sup>	C1 <sup>[1]</sup>	I/O	<b>P3[13]</b> — General purpose digital input/output pin.
			I/O	<b>D13</b> — External memory data line 13.
P3[14]/D14	21 <sup>[1]</sup>	H2 <sup>[1]</sup>	I/O	<b>P3[14]</b> — General purpose digital input/output pin.
			I/O	<b>D14</b> — External memory data line 14.
P3[15]/D15	28 <sup>[1]</sup>	M1 <sup>[1]</sup>	I/O	<b>P3[15]</b> — General purpose digital input/output pin.
			I/O	<b>D15</b> — External memory data line 15.
P3[16]/D16/ PWM0[1]/TXD1	137 <sup>[1]</sup>	F17 <sup>[1]</sup>	I/O	<b>P3[16]</b> — General purpose digital input/output pin.
			I/O	<b>D16</b> — External memory data line 16.
			O	<b>PWM0[1]</b> — Pulse Width Modulator 0, output 1.
			O	<b>TXD1</b> — Transmitter output for UART1.
P3[17]/D17/ PWM0[2]/RXD1	143 <sup>[1]</sup>	F15 <sup>[1]</sup>	I/O	<b>P3[17]</b> — General purpose digital input/output pin.
			I/O	<b>D17</b> — External memory data line 17.
			O	<b>PWM0[2]</b> — Pulse Width Modulator 0, output 2.
			I	<b>RXD1</b> — Receiver input for UART1.
P3[18]/D18/ PWM0[3]/CTS1	151 <sup>[1]</sup>	C15 <sup>[1]</sup>	I/O	<b>P3[18]</b> — General purpose digital input/output pin.
			I/O	<b>D18</b> — External memory data line 18.
			O	<b>PWM0[3]</b> — Pulse Width Modulator 0, output 3.
			I	<b>CTS1</b> — Clear to Send input for UART1.
P3[19]/D19/ PWM0[4]/DCD1	161 <sup>[1]</sup>	B14 <sup>[1]</sup>	I/O	<b>P3[19]</b> — General purpose digital input/output pin.
			I/O	<b>D19</b> — External memory data line 19.
			O	<b>PWM0[4]</b> — Pulse Width Modulator 0, output 4.
			I	<b>DCD1</b> — Data Carrier Detect input for UART1.

Table 4. Pin description ...continued

Symbol	Pin	Ball	Type	Description
P3[20]/D20/ PWM0[5]/DSR1	167 <sup>[1]</sup>	A13 <sup>[1]</sup>	I/O	<b>P3[20]</b> — General purpose digital input/output pin.
			I/O	<b>D20</b> — External memory data line 20.
			O	<b>PWM0[5]</b> — Pulse Width Modulator 0, output 5.
			I	<b>DSR1</b> — Data Set Ready input for UART1.
P3[21]/D21/ PWM0[6]/DTR1	175 <sup>[1]</sup>	C10 <sup>[1]</sup>	I/O	<b>P3[21]</b> — General purpose digital input/output pin.
			I/O	<b>D21</b> — External memory data line 21.
			O	<b>PWM0[6]</b> — Pulse Width Modulator 0, output 6.
			O	<b>DTR1</b> — Data Terminal Ready output for UART1.
P3[22]/D22/ PCAP0[0]/R11	195 <sup>[1]</sup>	C6 <sup>[1]</sup>	I/O	<b>P3[22]</b> — General purpose digital input/output pin.
			I/O	<b>D22</b> — External memory data line 22.
			I	<b>PCAP0[0]</b> — Capture input for PWM0, channel 0.
			I	<b>R11</b> — Ring Indicator input for UART1.
P3[23]/D23/ CAP0[0]/ PCAP1[0]	65 <sup>[1]</sup>	T6 <sup>[1]</sup>	I/O	<b>P3[23]</b> — General purpose digital input/output pin.
			I/O	<b>D23</b> — External memory data line 23.
			I	<b>CAP0[0]</b> — Capture input for Timer 0, channel 0.
			I	<b>PCAP1[0]</b> — Capture input for PWM1, channel 0.
P3[24]/D24/ CAP0[1]/ PWM1[1]	58 <sup>[1]</sup>	R5 <sup>[1]</sup>	I/O	<b>P3[24]</b> — General purpose digital input/output pin.
			I/O	<b>D24</b> — External memory data line 24.
			I	<b>CAP0[1]</b> — Capture input for Timer 0, channel 1.
			O	<b>PWM1[1]</b> — Pulse Width Modulator 1, output 1.
P3[25]/D25/ MAT0[0]/ PWM1[2]	56 <sup>[1]</sup>	U2 <sup>[1]</sup>	I/O	<b>P3[25]</b> — General purpose digital input/output pin.
			I/O	<b>D25</b> — External memory data line 25.
			O	<b>MAT0[0]</b> — Match output for Timer 0, channel 0.
			O	<b>PWM1[2]</b> — Pulse Width Modulator 1, output 2.
P3[26]/D26/ MAT0[1]/ PWM1[3]	55 <sup>[1]</sup>	T3 <sup>[1]</sup>	I/O	<b>P3[26]</b> — General purpose digital input/output pin.
			I/O	<b>D26</b> — External memory data line 26.
			O	<b>MAT0[1]</b> — Match output for Timer 0, channel 1.
			O	<b>PWM1[3]</b> — Pulse Width Modulator 1, output 3.
P3[27]/D27/ CAP1[0]/ PWM1[4]	203 <sup>[1]</sup>	A1 <sup>[1]</sup>	I/O	<b>P3[27]</b> — General purpose digital input/output pin.
			I/O	<b>D27</b> — External memory data line 27.
			I	<b>CAP1[0]</b> — Capture input for Timer 1, channel 0.
			O	<b>PWM1[4]</b> — Pulse Width Modulator 1, output 4.
P3[28]/D28/ CAP1[1]/ PWM1[5]	5 <sup>[1]</sup>	D2 <sup>[1]</sup>	I/O	<b>P3[28]</b> — General purpose digital input/output pin.
			I/O	<b>D28</b> — External memory data line 28.
			I	<b>CAP1[1]</b> — Capture input for Timer 1, channel 1.
			O	<b>PWM1[5]</b> — Pulse Width Modulator 1, output 5.
P3[29]/D29/ MAT1[0]/ PWM1[6]	11 <sup>[1]</sup>	F3 <sup>[1]</sup>	I/O	<b>P3[29]</b> — General purpose digital input/output pin.
			I/O	<b>D29</b> — External memory data line 29.
			O	<b>MAT1[0]</b> — Match output for Timer 1, channel 0.
			O	<b>PWM1[6]</b> — Pulse Width Modulator 1, output 6.

Table 4. Pin description ...continued

Symbol	Pin	Ball	Type	Description
P3[30]/D30/ MAT1[1]/ RTS1	19 <sup>[1]</sup>	H3 <sup>[1]</sup>	I/O	<b>P3[30]</b> — General purpose digital input/output pin.
			I/O	<b>D30</b> — External memory data line 30.
			O	<b>MAT1[1]</b> — Match output for Timer 1, channel 1.
			O	<b>RTS1</b> — Request to Send output for UART1.
P3[31]/D31/ MAT1[2]	25 <sup>[1]</sup>	J3 <sup>[1]</sup>	I/O	<b>P3[31]</b> — General purpose digital input/output pin.
			I/O	<b>D31</b> — External memory data line 31.
			O	<b>MAT1[2]</b> — Match output for Timer 1, channel 2.
P4[0] to P4[31]			I/O	<b>Port 4:</b> Port 4 is a 32-bit I/O port with individual direction controls for each bit. The operation of port 4 pins depends upon the pin function selected via the Pin Connect block.
P4[0]/A0	75 <sup>[1]</sup>	U9 <sup>[1]</sup>	I/O	<b>P4[0]</b> — General purpose digital input/output pin.
			I/O	<b>A0</b> — External memory address line 0.
P4[1]/A1	79 <sup>[1]</sup>	U10 <sup>[1]</sup>	I/O	<b>P4[1]</b> — General purpose digital input/output pin.
			I/O	<b>A1</b> — External memory address line 1.
P4[2]/A2	83 <sup>[1]</sup>	T11 <sup>[1]</sup>	I/O	<b>P4[2]</b> — General purpose digital input/output pin.
			I/O	<b>A2</b> — External memory address line 2.
P4[3]/A3	97 <sup>[1]</sup>	U16 <sup>[1]</sup>	I/O	<b>P4[3]</b> — General purpose digital input/output pin.
			I/O	<b>A3</b> — External memory address line 3.
P4[4]/A4	103 <sup>[1]</sup>	R15 <sup>[1]</sup>	I/O	<b>P4[4]</b> — General purpose digital input/output pin.
			I/O	<b>A4</b> — External memory address line 4.
P4[5]/A5	107 <sup>[1]</sup>	R16 <sup>[1]</sup>	I/O	<b>P4[5]</b> — General purpose digital input/output pin.
			I/O	<b>A5</b> — External memory address line 5.
P4[6]/A6	113 <sup>[1]</sup>	M14 <sup>[1]</sup>	I/O	<b>P4[6]</b> — General purpose digital input/output pin.
			I/O	<b>A6</b> — External memory address line 6.
P4[7]/A7	121 <sup>[1]</sup>	L16 <sup>[1]</sup>	I/O	<b>P4[7]</b> — General purpose digital input/output pin.
			I/O	<b>A7</b> — External memory address line 7.
P4[8]/A8	127 <sup>[1]</sup>	J17 <sup>[1]</sup>	I/O	<b>P4[8]</b> — General purpose digital input/output pin.
			I/O	<b>A8</b> — External memory address line 8.
P4[9]/A9	131 <sup>[1]</sup>	H17 <sup>[1]</sup>	I/O	<b>P4[9]</b> — General purpose digital input/output pin.
			I/O	<b>A9</b> — External memory address line 9.
P4[10]/A10	135 <sup>[1]</sup>	G17 <sup>[1]</sup>	I/O	<b>P4[10]</b> — General purpose digital input/output pin.
			I/O	<b>A10</b> — External memory address line 10.
P4[11]/A11	145 <sup>[1]</sup>	F14 <sup>[1]</sup>	I/O	<b>P4[11]</b> — General purpose digital input/output pin.
			I/O	<b>A11</b> — External memory address line 11.
P4[12]/A12	149 <sup>[1]</sup>	C16 <sup>[1]</sup>	I/O	<b>P4[12]</b> — General purpose digital input/output pin.
			I/O	<b>A12</b> — External memory address line 12.
P4[13]/A13	155 <sup>[1]</sup>	B16 <sup>[1]</sup>	I/O	<b>P4[13]</b> — General purpose digital input/output pin.
			I/O	<b>A13</b> — External memory address line 13.
P4[14]/A14	159 <sup>[1]</sup>	B15 <sup>[1]</sup>	I/O	<b>P4[14]</b> — General purpose digital input/output pin.
			I/O	<b>A14</b> — External memory address line 14.

Table 4. Pin description ...continued

Symbol	Pin	Ball	Type	Description
P4[15]/A15	173 <sup>[1]</sup>	A11 <sup>[1]</sup>	I/O	<b>P4[15]</b> — General purpose digital input/output pin.
			I/O	<b>A15</b> — External memory address line 15.
P4[16]/A16	101 <sup>[1]</sup>	U17 <sup>[1]</sup>	I/O	<b>P4[16]</b> — General purpose digital input/output pin.
			I/O	<b>A16</b> — External memory address line 16.
P4[17]/A17	104 <sup>[1]</sup>	P14 <sup>[1]</sup>	I/O	<b>P4[17]</b> — General purpose digital input/output pin.
			I/O	<b>A17</b> — External memory address line 17.
P4[18]/A18	105 <sup>[1]</sup>	P15 <sup>[1]</sup>	I/O	<b>P4[18]</b> — General purpose digital input/output pin.
			I/O	<b>A18</b> — External memory address line 18.
P4[19]/A19	111 <sup>[1]</sup>	P16 <sup>[1]</sup>	I/O	<b>P4[19]</b> — General purpose digital input/output pin.
			I/O	<b>A19</b> — External memory address line 19.
P4[20]/A20/ SDA2/SCK1	109 <sup>[1]</sup>	R17 <sup>[1]</sup>	I/O	<b>P4[20]</b> — General purpose digital input/output pin.
			I/O	<b>A20</b> — External memory address line 20.
			I/O	<b>SDA2</b> — I <sup>2</sup> C2 data input/output (this is not an open-drain pin).
			I/O	<b>SCK1</b> — Serial Clock for SSP1.
P4[21]/A21/ SCL2/SSEL1	115 <sup>[1]</sup>	M15 <sup>[1]</sup>	I/O	<b>P4[21]</b> — General purpose digital input/output pin.
			I/O	<b>A21</b> — External memory address line 21.
			I/O	<b>SCL2</b> — I <sup>2</sup> C2 clock input/output (this is not an open-drain pin).
			I/O	<b>SSEL1</b> — Slave Select for SSP1.
P4[22]/A22/ TXD2/MISO1	123 <sup>[1]</sup>	K14 <sup>[1]</sup>	I/O	<b>P4[22]</b> — General purpose digital input/output pin.
			I/O	<b>A22</b> — External memory address line 22.
			O	<b>TXD2</b> — Transmitter output for UART2.
			I/O	<b>MISO1</b> — Master In Slave Out for SSP1.
P4[23]/A23/ RXD2/MOSI1	129 <sup>[1]</sup>	J15 <sup>[1]</sup>	I/O	<b>P4[23]</b> — General purpose digital input/output pin.
			I/O	<b>A23</b> — External memory address line 23.
			I	<b>RXD2</b> — Receiver input for UART2.
			I/O	<b>MOSI1</b> — Master Out Slave In for SSP1.
P4[24]/ $\overline{\text{OE}}$	183 <sup>[1]</sup>	B8 <sup>[1]</sup>	I/O	<b>P4[24]</b> — General purpose digital input/output pin.
			O	$\overline{\text{OE}}$ — LOW active Output Enable signal.
P4[25]/ $\overline{\text{WE}}$	179 <sup>[1]</sup>	B9 <sup>[1]</sup>	I/O	<b>P4[25]</b> — General purpose digital input/output pin.
			O	$\overline{\text{WE}}$ — LOW active Write Enable signal.
P4[26]/BLS0	119 <sup>[1]</sup>	L15 <sup>[1]</sup>	I/O	<b>P4[26]</b> — General purpose digital input/output pin.
			O	<b>BLS0</b> — LOW active Byte Lane select signal 0.
P4[27]/BLS1	139 <sup>[1]</sup>	G15 <sup>[1]</sup>	I/O	<b>P4[27]</b> — General purpose digital input/output pin.
			O	<b>BLS1</b> — LOW active Byte Lane select signal 1.
P4[28]/BLS2/ MAT2[0]/TXD3	170 <sup>[1]</sup>	C11 <sup>[1]</sup>	I/O	<b>P4 [28]</b> — General purpose digital input/output pin.
			O	<b>BLS2</b> — LOW active Byte Lane select signal 2.
			O	<b>MAT2[0]</b> — Match output for Timer 2, channel 0.
			O	<b>TXD3</b> — Transmitter output for UART3.

Table 4. Pin description ...continued

Symbol	Pin	Ball	Type	Description
P4[29]/BLS3/ MAT2[1]/RXD3	176 <sup>[1]</sup>	B10 <sup>[1]</sup>	I/O	<b>P4[29]</b> — General purpose digital input/output pin.
			O	<b>BLS3</b> — LOW active Byte Lane select signal 3.
			O	<b>MAT2[1]</b> — Match output for Timer 2, channel 1.
			I	<b>RXD3</b> — Receiver input for UART3.
P4[30]/CS0	187 <sup>[1]</sup>	B7 <sup>[1]</sup>	I/O	<b>P4[30]</b> — General purpose digital input/output pin.
			O	<b>CS0</b> — LOW active Chip Select 0 signal.
P4[31]/CS1	193 <sup>[1]</sup>	A4 <sup>[1]</sup>	I/O	<b>P4[31]</b> — General purpose digital input/output pin.
			O	<b>CS1</b> — LOW active Chip Select 1 signal.
ALARM	37 <sup>[8]</sup>	N1 <sup>[8]</sup>	O	<b>ALARM</b> — RTC controlled output. This is a 1.8 V pin. It goes HIGH when a RTC alarm is generated.
USB_D-2	52	U1	I/O	<b>USB_D-2</b> — USB port 2 bidirectional D- line.
DBGEN	9 <sup>[1]</sup>	F4 <sup>[1]</sup>	I	<b>DBGEN</b> — JTAG interface control signal. Also used for boundary scanning.
TDO	2 <sup>[1]</sup>	D3 <sup>[1]</sup>	O	<b>TDO</b> — Test Data out for JTAG interface.
TDI	4 <sup>[1]</sup>	C2 <sup>[1]</sup>	I	<b>TDI</b> — Test Data in for JTAG interface.
TMS	6 <sup>[1]</sup>	E3 <sup>[1]</sup>	I	<b>TMS</b> — Test Mode Select for JTAG interface.
TRST	8 <sup>[1]</sup>	D1 <sup>[1]</sup>	I	<b>TRST</b> — Test Reset for JTAG interface.
TCK	10 <sup>[1]</sup>	E2 <sup>[1]</sup>	I	<b>TCK</b> — Test Clock for JTAG interface. This clock must be slower than 1/6 of the CPU clock (CCLK) for the JTAG interface to operate.
RTCK	206 <sup>[1]</sup>	C3 <sup>[1]</sup>	I/O	<b>RTCK</b> — JTAG interface control signal.
				<b>Note:</b> LOW on this pin while $\overline{\text{RESET}}$ is LOW enables ETM pins (P2[9:0]) to operate as Trace port after reset.
RSTOUT	29	K3	O	<b>RSTOUT</b> — This is a 1.8 V pin. LOW on this pin indicates LPC2460 being in Reset state.
RESET	35 <sup>[7]</sup>	M2 <sup>[7]</sup>	I	<b>external reset input:</b> A LOW on this pin resets the device, causing I/O ports and peripherals to take on their default states, and processor execution to begin at address 0. TTL with hysteresis, 5 V tolerant.
XTAL1	44 <sup>[8]</sup>	M4 <sup>[8]</sup>	I	Input to the oscillator circuit and internal clock generator circuits.
XTAL2	46 <sup>[8]</sup>	N4 <sup>[8]</sup>	O	Output from the oscillator amplifier.
RTCX1	34 <sup>[8]</sup>	K2 <sup>[8]</sup>	I	Input to the RTC oscillator circuit.
RTCX2	36 <sup>[8]</sup>	L2 <sup>[8]</sup>	O	Output from the RTC oscillator circuit.
V <sub>SSIO</sub>	33, 63, 77, 93, 114, 133, 148, 169, 189, 200 <sup>[9]</sup>	L3, T5, R9, P12, N16, H14, E15, A12, B6, A2 <sup>[9]</sup>	I	<b>ground:</b> 0 V reference for the digital I/O pins.
V <sub>SSCORE</sub>	32, 84, 172 <sup>[9]</sup>	K4, P10, D12 <sup>[9]</sup>	I	<b>ground:</b> 0 V reference for the core.
V <sub>SSA</sub>	22 <sup>[10]</sup>	J2 <sup>[10]</sup>	I	<b>analog ground:</b> 0 V reference. This should nominally be the same voltage as V <sub>SS</sub> , but should be isolated to minimize noise and error.

Table 4. Pin description ...continued

Symbol	Pin	Ball	Type	Description
$V_{DD(3V3)}$	15, 60, 71, 89, 112, 125, 146, 165, 181, 198 <sup>[11]</sup>	G3, P6, P8, U13, P17, K16, C17, B13, C9, D7 <sup>[11]</sup>	I	<b>3.3 V supply voltage:</b> This is the power supply voltage for the I/O ports.
NC	30, 117, 141 <sup>[12]</sup>	J4, L14, G14 <sup>[12]</sup>	I	<b>Not Connected pins:</b> These pins must be left unconnected (floating).
$V_{DD(DCDC)(3V3)}$	26, 86, 174 <sup>[13]</sup>	H4, P11, D11 <sup>[13]</sup>	I	<b>3.3 V DC-to-DC converter supply voltage:</b> This is the power supply for the on-chip DC-to-DC converter.
$V_{DDA}$	20 <sup>[14]</sup>	G4 <sup>[14]</sup>	I	<b>analog 3.3 V pad supply voltage:</b> This should be nominally the same voltage as $V_{DD(3V3)}$ but should be isolated to minimize noise and error. This voltage is used to power the ADC and DAC.
VREF	24 <sup>[14]</sup>	K1 <sup>[14]</sup>	I	<b>ADC reference:</b> This should be nominally the same voltage as $V_{DD(3V3)}$ but should be isolated to minimize noise and error. The level on this pin is used as a reference for ADC and DAC.
VBAT	38 <sup>[14]</sup>	M3 <sup>[14]</sup>	I	<b>RTC power supply:</b> 3.3 V on this pin supplies the power to the RTC.

- [1] 5 V tolerant pad providing digital I/O functions with TTL levels and hysteresis.
- [2] 5 V tolerant pad providing digital I/O functions (with TTL levels and hysteresis) and analog input. When configured as a ADC input, digital section of the pad is disabled.
- [3] 5 V tolerant pad providing digital I/O with TTL levels and hysteresis and analog output function. When configured as the DAC output, digital section of the pad is disabled.
- [4] Open-drain 5 V tolerant digital I/O I<sup>2</sup>C-bus 400 kHz specification compatible pad. It requires an external pull-up to provide output functionality. When power is switched off, this pin connected to the I<sup>2</sup>C-bus is floating and does not disturb the I<sup>2</sup>C lines.
- [5] Pad provides digital I/O and USB functions. It is designed in accordance with the *USB specification, revision 2.0* (Full-speed and Low-speed mode only).
- [6] 5 V tolerant pad with 5 ns glitch filter providing digital I/O functions with TTL levels and hysteresis.
- [7] 5 V tolerant pad with 20 ns glitch filter providing digital I/O function with TTL levels and hysteresis.
- [8] Pad provides special analog functionality.
- [9] Pad provides special analog functionality.
- [10] Pad provides special analog functionality.
- [11] Pad provides special analog functionality.
- [12] Pad provides special analog functionality.
- [13] Pad provides special analog functionality.
- [14] Pad provides special analog functionality.

## 7. Functional description

### 7.1 Architectural overview

The LPC2460 microcontroller consists of an ARM7TDMI-S CPU with emulation support, the ARM7 local bus for closely coupled, high-speed access to the majority of on-chip memory, the AMBA AHB interfacing to high-speed on-chip peripherals and external

memory, and the AMBA APB for connection to other on-chip peripheral functions. The microcontroller permanently configures the ARM7TDMI-S processor for little-endian byte order.

The LPC2460 implements two AHB buses in order to allow the Ethernet block to operate without interference caused by other system activity. The primary AHB, referred to as AHB1, includes the VIC, GPDMA controller, and EMC.

The second AHB, referred to as AHB2, includes only the Ethernet block and an associated 16 kB SRAM. In addition, a bus bridge is provided that allows the secondary AHB to be a bus master on AHB1, allowing expansion of Ethernet buffer space into off-chip memory or unused space in memory residing on AHB1.

In summary, bus masters with access to AHB1 are the ARM7 itself, the GPDMA function, and the Ethernet block (via the bus bridge from AHB2). Bus masters with access to AHB2 are the ARM7 and the Ethernet block.

AHB peripherals are allocated a 2 MB range of addresses at the very top of the 4 GB ARM memory space. Each AHB peripheral is allocated a 16 kB address space within the AHB address space. Lower speed peripheral functions are connected to the APB bus. The AHB to APB bridge interfaces the APB bus to the AHB bus. APB peripherals are also allocated a 2 MB range of addresses, beginning at the 3.5 GB address point. Each APB peripheral is allocated a 16 kB address space within the APB address space.

The ARM7TDMI-S processor is a general purpose 32-bit microprocessor, which offers high performance and very low power consumption. The ARM architecture is based on Reduced Instruction Set Computer (RISC) principles, and the instruction set and related decode mechanism are much simpler than those of microprogrammed complex instruction set computers. This simplicity results in a high instruction throughput and impressive real-time interrupt response from a small and cost-effective processor core.

Pipeline techniques are employed so that all parts of the processing and memory systems can operate continuously. Typically, while one instruction is being executed, its successor is being decoded, and a third instruction is being fetched from memory.

The ARM7TDMI-S processor also employs a unique architectural strategy known as Thumb, which makes it ideally suited to high-volume applications with memory restrictions, or applications where code density is an issue.

The key idea behind Thumb is that of a super-reduced instruction set. Essentially, the ARM7TDMI-S processor has two instruction sets:

- the standard 32-bit ARM set
- a 16-bit Thumb set

The Thumb set's 16-bit instruction length allows it to approach higher density compared to standard ARM code while retaining most of the ARM's performance.

## 7.2 On-chip SRAM

The LPC2460 includes a SRAM memory of 64 kB reserved for the ARM processor exclusive use. This RAM may be used for code and/or data storage and may be accessed as 8 bits, 16 bits, and 32 bits.



A 16 kB SRAM block serving as a buffer for the Ethernet controller and a 16 kB SRAM associated with the second AHB bus can be used both for data and code storage, too. The 2 kB RTC SRAM can be used for data storage only. The RTC SRAM is battery powered and retains the content in the absence of the main power supply.

### 7.3 Memory map

The LPC2460 memory map incorporates several distinct regions as shown in [Table 5](#) and [Figure 4](#).

In addition, the CPU interrupt vectors may be remapped to allow them to reside in boot ROM or SRAM (see [Section 7.25.6](#)).

**Table 5. LPC2460 memory usage and details**

Address range	General use	Address range details and description		
0x0000 0000 to 0x3FFF FFFF	Fast I/O	0x3FFF C000 - 0x3FFF FFFF Fast GPIO registers		
0x4000 0000 to 0x7FFF FFFF	On-chip RAM	0x4000 0000 - 0x4000 FFFF RAM (64 kB)		
		0x7FE0 0000 - 0x7FE0 3FFF Ethernet RAM (16 kB)		
		0x7FD0 0000 - 0x7FD0 3FFF USB RAM (16 kB)		
0x8000 0000 to 0xDFFF FFFF	Off-Chip Memory	Four static memory banks, 16 MB each		
		0x8000 0000 - 0x80FF FFFF Static memory bank 0		
		0x8100 0000 - 0x81FF FFFF Static memory bank 1		
		0x8200 0000 - 0x82FF FFFF Static memory bank 2		
		0x8300 0000 - 0x83FF FFFF Static memory bank 3		
		Four dynamic memory banks, 256 MB each		
		0xA000 0000 - 0xAFFF FFFF Dynamic memory bank 0		
		0xB000 0000 - 0xBFFF FFFF Dynamic memory bank 1		
		0xC000 0000 - 0xCFFF FFFF Dynamic memory bank 2		
		0xD000 0000 - 0xDFFF FFFF Dynamic memory bank 3		
		0xE000 0000 to 0xEFFF FFFF	APB Peripherals	36 peripheral blocks, 16 kB each
		0xF000 0000 to 0xFFFF FFFF	AHB peripherals	

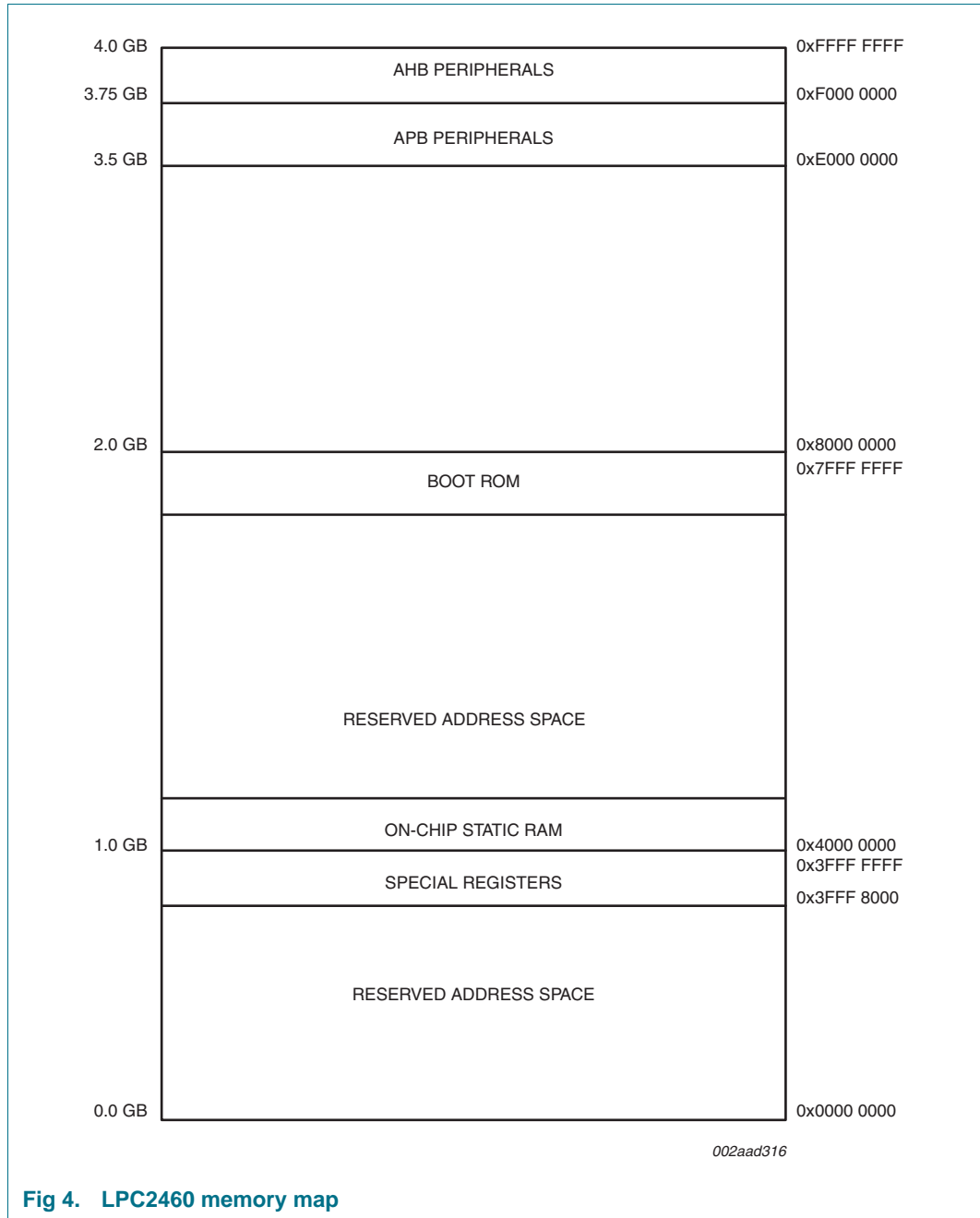

### 7.4 Interrupt controller

The ARM processor core has two interrupt inputs called Interrupt Request (IRQ) and Fast Interrupt Request (FIQ). The VIC takes 32 interrupt request inputs which can be programmed as FIQ or vectored IRQ types. The programmable assignment scheme means that priorities of interrupts from the various peripherals can be dynamically assigned and adjusted.

FIQs have the highest priority. If more than one request is assigned to FIQ, the VIC ORs the requests to produce the FIQ signal to the ARM processor. The fastest possible FIQ latency is achieved when only one request is classified as FIQ, because then the FIQ

service routine can simply start dealing with that device. But if more than one request is assigned to the FIQ class, the FIQ service routine can read a word from the VIC that identifies which FIQ source(s) is (are) requesting an interrupt.

Vectored IRQs, which include all interrupt requests that are not classified as FIQs, have a programmable interrupt priority. When more than one interrupt is assigned the same priority and occur simultaneously, the one connected to the lowest numbered VIC channel will be serviced first.

The VIC ORs the requests from all of the vectored IRQs to produce the IRQ signal to the ARM processor. The IRQ service routine can start by reading a register from the VIC and jumping to the address supplied by that register.

### 7.4.1 Interrupt sources

Each peripheral device has one interrupt line connected to the VIC but may have several interrupt flags. Individual interrupt flags may also represent more than one interrupt source.

Any pin on PORT0 and PORT2 (total of 64 pins) regardless of the selected function, can be programmed to generate an interrupt on a rising edge, a falling edge, or both. Such interrupt request coming from PORT0 and/or PORT2 will be combined with the EINT3 interrupt requests.

## 7.5 Pin connect block

The pin connect block allows selected pins of the microcontroller to have more than one function. Configuration registers control the multiplexers to allow connection between the pin and the on chip peripherals.

Peripherals should be connected to the appropriate pins prior to being activated and prior to any related interrupt(s) being enabled. Activity of any enabled peripheral function that is not mapped to a related pin should be considered undefined.

## 7.6 External memory controller

The LPC2460 EMC is an ARM PrimeCell MultiPort Memory Controller peripheral offering support for asynchronous static memory devices such as RAM, ROM, and flash. In addition, it can be used as an interface with off-chip memory-mapped devices and peripherals. The EMC is an Advanced Microcontroller Bus Architecture (AMBA) compliant peripheral.

### 7.6.1 Features

- Dynamic memory interface support including Single Data Rate SDRAM.
- Asynchronous static memory device support including RAM, ROM, and flash, with or without asynchronous page mode.
- Low transaction latency.
- Read and write buffers to reduce latency and to improve performance.
- 8/16/32 data and 24 address lines wide static memory support.
- 16 bit and 32 bit wide chip select SDRAM memory support.
- Static memory features include:

- Asynchronous page mode read
- Programmable Wait States
- Bus turnaround delay
- Output enable and write enable delays
- Extended wait
- Four chip selects for synchronous memory and four chip selects for static memory devices.
- Power-saving modes dynamically control CKE and CLKOUT to SDRAMs.
- Dynamic memory self-refresh mode controlled by software.
- Controller supports 2 k, 4 k, and 8 k row address synchronous memory parts. That is typical 512 MB, 256 MB, and 128 MB parts, with 4, 8, 16, or 32 data bits per device.
- Separate reset domains allow the for auto-refresh through a chip reset if desired.

**Note:** Synchronous static memory devices (synchronous burst mode) are not supported.

## 7.7 General purpose DMA controller

The GPDMA is an AMBA AHB compliant peripheral allowing selected LPC2460 peripherals to have DMA support.

The GPDMA enables peripheral-to-memory, memory-to-peripheral, peripheral-to-peripheral, and memory-to-memory transactions. Each DMA stream provides unidirectional serial DMA transfers for a single source and destination. For example, a bidirectional port requires one stream for transmit and one for receive. The source and destination areas can each be either a memory region or a peripheral, and can be accessed through the AHB master.

### 7.7.1 Features

- Two DMA channels. Each channel can support a unidirectional transfer.
- The GPDMA can transfer data between the 16 kB SRAM, external memory, and peripherals such as the SD/MMC, two SSPs, and the I<sup>2</sup>S interface.
- Single DMA and burst DMA request signals. Each peripheral connected to the GPDMA can assert either a burst DMA request or a single DMA request. The DMA burst size is set by programming the GPDMA.
- Memory-to-memory, memory-to-peripheral, peripheral-to-memory, and peripheral-to-peripheral transfers.
- Scatter or gather DMA is supported through the use of linked lists. This means that the source and destination areas do not have to occupy contiguous areas of memory.
- Hardware DMA channel priority. Each DMA channel has a specific hardware priority. DMA channel 0 has the highest priority and channel 1 has the lowest priority. If requests from two channels become active at the same time, the channel with the highest priority is serviced first.
- AHB slave DMA programming interface. The GPDMA is programmed by writing to the DMA control registers over the AHB slave interface.
- One AHB bus master for transferring data. This interface transfers data when a DMA request goes active.

- 32-bit AHB master bus width.
- Incrementing or non-incrementing addressing for source and destination.
- Programmable DMA burst size. The DMA burst size can be programmed to more efficiently transfer data. Usually the burst size is set to half the size of the FIFO in the peripheral.
- Internal four-word FIFO per channel.
- Supports 8-bit, 16-bit, and 32-bit wide transactions.
- An interrupt to the processor can be generated on a DMA completion or when a DMA error has occurred.
- Interrupt masking. The DMA error and DMA terminal count interrupt requests can be masked.
- Raw interrupt status. The DMA error and DMA count raw interrupt status can be read prior to masking.

## 7.8 Fast general purpose parallel I/O

Device pins that are not connected to a specific peripheral function are controlled by the GPIO registers. Pins may be dynamically configured as inputs or outputs. Separate registers allow setting or clearing any number of outputs simultaneously. The value of the output register may be read back as well as the current state of the port pins.

LPC2460 use accelerated GPIO functions:

- GPIO registers are relocated to the ARM local bus so that the fastest possible I/O timing can be achieved.
- Mask registers allow treating sets of port bits as a group, leaving other bits unchanged.
- All GPIO registers are byte and half-word addressable.
- Entire port value can be written in one instruction.

Additionally, any pin on PORT0 and PORT2 (total of 64 pins) that is not configured as an analog input/output can be programmed to generate an interrupt on a rising edge, a falling edge, or both. The edge detection is asynchronous, so it may operate when clocks are not present such as during Power-down mode. Each enabled interrupt can be used to wake the chip up from Power-down mode.

### 7.8.1 Features

- Bit level set and clear registers allow a single instruction to set or clear any number of bits in one port.
- Direction control of individual bits.
- All I/O default to inputs after reset.
- Backward compatibility with other earlier devices is maintained with legacy PORT0 and PORT1 registers appearing at the original addresses on the APB bus.

## 7.9 Ethernet

The Ethernet block contains a full featured 10 Mbit/s or 100 Mbit/s Ethernet MAC designed to provide optimized performance through the use of DMA hardware acceleration. Features include a generous suite of control registers, half or full duplex operation, flow control, control frames, hardware acceleration for transmit retry, receive packet filtering and wake-up on LAN activity. Automatic frame transmission and reception with scatter-gather DMA off-loads many operations from the CPU.

The Ethernet block and the CPU share a dedicated AHB subsystem that is used to access the Ethernet SRAM for Ethernet data, control, and status information. All other AHB traffic in the LPC2460 takes place on a different AHB subsystem, effectively separating Ethernet activity from the rest of the system. The Ethernet DMA can also access off-chip memory via the EMC, as well as the SRAM located on another AHB. However, using memory other than the Ethernet SRAM, especially off-chip memory, will slow Ethernet access to memory and increase the loading of its AHB.

The Ethernet block interfaces between an off-chip Ethernet PHY using the Media Independent Interface (MII) or Reduced MII (RMII) protocol and the on-chip Media Independent Interface Management (MIIM) serial bus.

### 7.9.1 Features

- Ethernet standards support:
  - Supports 10 Mbit/s or 100 Mbit/s PHY devices including 10 Base-T, 100 Base-TX, 100 Base-FX, and 100 Base-T4.
  - Fully compliant with IEEE standard 802.3.
  - Fully compliant with 802.3x Full Duplex Flow Control and Half Duplex back pressure.
  - Flexible transmit and receive frame options.
  - Virtual Local Area Network (VLAN) frame support.
- Memory management:
  - Independent transmit and receive buffers memory mapped to shared SRAM.
  - DMA managers with scatter/gather DMA and arrays of frame descriptors.
  - Memory traffic optimized by buffering and pre-fetching.
- Enhanced Ethernet features:
  - Receive filtering.
  - Multicast and broadcast frame support for both transmit and receive.
  - Optional automatic Frame Check Sequence (FCS) insertion with Circular Redundancy Check (CRC) for transmit.
  - Selectable automatic transmit frame padding.
  - Over-length frame support for both transmit and receive allows any length frames.
  - Promiscuous receive mode.
  - Automatic collision back-off and frame retransmission.
  - Includes power management by clock switching.

- Wake-on-LAN power management support allows system wake-up: using the receive filters or a magic frame detection filter.
- Physical interface:
  - Attachment of external PHY chip through standard MII or RMII interface.
  - PHY register access is available via the MIIM interface.

## 7.10 USB interface

The Universal Serial Bus (USB) is a 4-wire bus that supports communication between a host and one or more (up to 127) peripherals. The Host Controller allocates the USB bandwidth to attached devices through a token-based protocol. The bus supports hot plugging and dynamic configuration of the devices. All transactions are initiated by the Host Controller.

The LPC2460 USB interface includes a device, Host, and OTG Controller. Details on typical USB interfacing solutions can be found in [Section 11.1 “Suggested USB interface solutions” on page 55](#)

### 7.10.1 USB device controller

The device controller enables 12 Mbit/s data exchange with a USB Host Controller. It consists of a register interface, serial interface engine, endpoint buffer memory, and a DMA controller. The serial interface engine decodes the USB data stream and writes data to the appropriate endpoint buffer. The status of a completed USB transfer or error condition is indicated via status registers. An interrupt is also generated if enabled. When enabled, the DMA controller transfers data between the endpoint buffer and the USB RAM.

#### 7.10.1.1 Features

- Fully compliant with *USB 2.0 specification* (full speed).
- Supports 32 physical (16 logical) endpoints with a 4 kB endpoint buffer RAM.
- Supports Control, Bulk, Interrupt and Isochronous endpoints.
- Scalable realization of endpoints at run time.
- Endpoint Maximum packet size selection (up to USB maximum specification) by software at run time.
- Supports SoftConnect and GoodLink features.
- While USB is in the Suspend mode, LPC2460 can enter one of the reduced power modes and wake up on USB activity.
- Supports DMA transfers with the DMA RAM of 16 kB on all non-control endpoints.
- Allows dynamic switching between CPU-controlled and DMA modes.
- Double buffer implementation for Bulk and Isochronous endpoints.

### 7.10.2 USB Host Controller

The Host Controller enables full- and low-speed data exchange with USB devices attached to the bus. It consists of register interface, serial interface engine and DMA controller. The register interface complies with the OHCI specification.

### 7.10.2.1 Features

- OHCI compliant.
- Two downstream ports.
- Supports per-port power switching.

### 7.10.3 USB OTG Controller

USB OTG (On-The-Go) is a supplement to the *USB 2.0 specification* that augments the capability of existing mobile devices and USB peripherals by adding host functionality for connection to USB peripherals.

The OTG Controller integrates the Host Controller, device controller, and a master-only I<sup>2</sup>C interface to implement OTG dual-role device functionality. The dedicated I<sup>2</sup>C interface controls an external OTG transceiver.

#### 7.10.3.1 Features

- Fully compliant with *On-The-Go supplement to the USB 2.0 Specification, Revision 1.0a*.
- Hardware support for Host Negotiation Protocol (HNP).
- Includes a programmable timer required for HNP and Session Request Protocol (SRP).
- Supports any OTG transceiver compliant with the *OTG Transceiver Specification (CEA-2011), Rev. 1.0*.

## 7.11 CAN controller and acceptance filters

The Controller Area Network (CAN) is a serial communications protocol which efficiently supports distributed real-time control with a very high level of security. Its domain of application ranges from high-speed networks to low cost multiplex wiring.

The CAN block is intended to support multiple CAN buses simultaneously, allowing the device to be used as a gateway, switch, or router between two of CAN buses in industrial or automotive applications.

Each CAN controller has a register structure similar to the NXP SJA1000 and the PeliCAN Library block, but the 8-bit registers of those devices have been combined in 32-bit words to allow simultaneous access in the ARM environment. The main operational difference is that the recognition of received Identifiers, known in CAN terminology as Acceptance Filtering, has been removed from the CAN controllers and centralized in a global Acceptance Filter.

### 7.11.1 Features

- Two CAN controllers and buses.
- Data rates to 1 Mbit/s on each bus.
- 32-bit register and RAM access.
- Compatible with *CAN specification 2.0B, ISO 11898-1*.
- Global Acceptance Filter recognizes 11-bit and 29-bit receive identifiers for all CAN buses.



- Acceptance Filter can provide FullCAN-style automatic reception for selected Standard Identifiers.
- Full CAN messages can generate interrupts.

## 7.12 10-bit ADC

The LPC2460 contains one ADC. It is a single 10-bit successive approximation ADC with eight channels.

### 7.12.1 Features

- 10-bit successive approximation ADC
- Input multiplexing among 8 pins
- Power-down mode
- Measurement range 0 V to  $V_{i(VREF)}$
- 10-bit conversion time  $\geq 2.44 \mu\text{s}$
- Burst conversion mode for single or multiple inputs
- Optional conversion on transition of input pin or Timer Match signal
- Individual result registers for each ADC channel to reduce interrupt overhead

## 7.13 10-bit DAC

The DAC allows the LPC2460 to generate a variable analog output. The maximum output value of the DAC is  $V_{i(VREF)}$ .

### 7.13.1 Features

- 10-bit DAC
- Resistor string architecture
- Buffered output
- Power-down mode
- Selectable output drive

## 7.14 UARTs

The LPC2460 contains four UARTs. In addition to standard transmit and receive data lines, UART1 also provides a full modem control handshake interface.

The UARTs include a fractional baud rate generator. Standard baud rates such as 115200 can be achieved with any crystal frequency above 2 MHz.

### 7.14.1 Features

- 16 B Receive and Transmit FIFOs.
- Register locations conform to 16C550 industry standard.
- Receiver FIFO trigger points at 1 B, 4 B, 8 B, and 14 B.
- Built-in fractional baud rate generator covering wide range of baud rates without a need for external crystals of particular values.

- Fractional divider for baud rate control, auto baud capabilities and FIFO control mechanism that enables software flow control implementation.
- UART1 equipped with standard modem interface signals. This module also provides full support for hardware flow control (auto-CTS/RTS).
- UART3 includes an IrDA mode to support infrared communication.

## 7.15 SPI serial I/O controller

The LPC2460 contains one SPI controller. SPI is a full duplex serial interface designed to handle multiple masters and slaves connected to a given bus. Only a single master and a single slave can communicate on the interface during a given data transfer. During a data transfer the master always sends 8 bits to 16 bits of data to the slave, and the slave always sends 8 bits to 16 bits of data to the master.

### 7.15.1 Features

- Compliant with SPI specification
- Synchronous, Serial, Full Duplex Communication
- Combined SPI master and slave
- Maximum data bit rate of one eighth of the input clock rate
- 8 bits to 16 bits per transfer

## 7.16 SSP serial I/O controller

The LPC2460 contains two SSP controllers. The SSP controller is capable of operation on a SPI, 4-wire SSI, or Microwire bus. It can interact with multiple masters and slaves on the bus. Only a single master and a single slave can communicate on the bus during a given data transfer. The SSP supports full duplex transfers, with frames of 4 bits to 16 bits of data flowing from the master to the slave and from the slave to the master. In practice, often only one of these data flows carries meaningful data.

### 7.16.1 Features

- Compatible with Motorola SPI, 4-wire TI SSI, and National Semiconductor Microwire buses
- Synchronous serial communication
- Master or slave operation
- 8-frame FIFOs for both transmit and receive
- 4-bit to 16-bit frame
- Maximum SPI bus data bit rate of one half (Master mode) and one twelfth (Slave mode) of the input clock rate
- DMA transfers supported by GPDMA

## 7.17 SD/MMC card interface

The Secure Digital and Multimedia Card Interface (MCI) allows access to external SD memory cards. The SD card interface conforms to the *SD Multimedia Card Specification Version 2.11*.

### 7.17.1 Features

- The MCI provides all functions specific to the SD/MMC memory card. These include the clock generation unit, power management control, and command and data transfer.
- Conforms to *Multimedia Card Specification v2.11*.
- Conforms to *Secure Digital Memory Card Physical Layer Specification, v0.96*.
- Can be used as a multimedia card bus or a secure digital memory card bus host. The SD/MMC can be connected to several multimedia cards or a single secure digital memory card.
- DMA supported through the GPDMA controller.

## 7.18 I<sup>2</sup>C-bus serial I/O controller

The LPC2460 contains three I<sup>2</sup>C-bus controllers.

The I<sup>2</sup>C-bus is bidirectional, for inter-IC control using only two wires: a serial clock line (SCL), and a serial data line (SDA). Each device is recognized by a unique address and can operate as either a receiver-only device (e.g., an LCD driver) or a transmitter with the capability to both receive and send information (such as memory). Transmitters and/or receivers can operate in either master or slave mode, depending on whether the chip has to initiate a data transfer or is only addressed. The I<sup>2</sup>C-bus is a multi-master bus and can be controlled by more than one bus master connected to it.

The I<sup>2</sup>C-bus implemented in LPC2460 supports bit rates up to 400 kbit/s (Fast I<sup>2</sup>C-bus).

### 7.18.1 Features

- I<sup>2</sup>C0 is a standard I<sup>2</sup>C compliant bus interface with open-drain pins.
- I<sup>2</sup>C1 and I<sup>2</sup>C2 use standard I/O pins and do not support powering off of individual devices connected to the same bus lines.
- Easy to configure as master, slave, or master/slave.
- Programmable clocks allow versatile rate control.
- Bidirectional data transfer between masters and slaves.
- Multi-master bus (no central master).
- Arbitration between simultaneously transmitting masters without corruption of serial data on the bus.
- Serial clock synchronization allows devices with different bit rates to communicate via one serial bus.
- Serial clock synchronization can be used as a handshake mechanism to suspend and resume serial transfer.
- The I<sup>2</sup>C-bus can be used for test and diagnostic purposes.

## 7.19 I<sup>2</sup>S-bus serial I/O controllers

The I<sup>2</sup>S-bus provides a standard communication interface for digital audio applications.

The I<sup>2</sup>S-bus specification defines a 3-wire serial bus using one data line, one clock line, and one word select signal. The basic I<sup>2</sup>S connection has one master, which is always the master, and one slave. The I<sup>2</sup>S interface on the LPC2460 provides a separate transmit and receive channel, each of which can operate as either a master or a slave.

### 7.19.1 Features

- The interface has separate input/output channels each of which can operate in master or slave mode.
- Capable of handling 8-bit, 16-bit, and 32-bit word sizes.
- Mono and stereo audio data supported.
- The sampling frequency can range from 16 kHz to 48 kHz (16, 22.05, 32, 44.1, 48) kHz.
- Configurable word select period in master mode (separately for I<sup>2</sup>S input and output).
- Two 8 word FIFO data buffers are provided, one for transmit and one for receive.
- Generates interrupt requests when buffer levels cross a programmable boundary.
- Two DMA requests, controlled by programmable buffer levels. These are connected to the GPDMA block.
- Controls include reset, stop and mute options separately for I<sup>2</sup>S input and I<sup>2</sup>S output.

### 7.20 General purpose 32-bit timers/external event counters

The LPC2460 includes four 32-bit Timer/Counters. The Timer/Counter is designed to count cycles of the system derived clock or an externally-supplied clock. It can optionally generate interrupts or perform other actions at specified timer values, based on four match registers. The Timer/Counter also includes four capture inputs to trap the timer value when an input signal transitions, optionally generating an interrupt.

#### 7.20.1 Features

- A 32-bit Timer/Counter with a programmable 32-bit prescaler.
- Counter or Timer operation.
- Up to four 32-bit capture channels per timer, that can take a snapshot of the timer value when an input signal transitions. A capture event may also optionally generate an interrupt.
- Four 32-bit match registers that allow:
  - Continuous operation with optional interrupt generation on match.
  - Stop timer on match with optional interrupt generation.
  - Reset timer on match with optional interrupt generation.
- Up to four external outputs corresponding to match registers, with the following capabilities:
  - Set LOW on match.
  - Set HIGH on match.
  - Toggle on match.
  - Do nothing on match.

## 7.21 Pulse width modulator

The PWM is based on the standard Timer block and inherits all of its features, although only the PWM function is pinned out on the LPC2460. The Timer is designed to count cycles of the system derived clock and optionally switch pins, generate interrupts or perform other actions when specified timer values occur, based on seven match registers. The PWM function is in addition to these features and is based on match register events.

The ability to separately control rising and falling edge locations allows the PWM to be used for more applications. For instance, multi-phase motor control typically requires three non-overlapping PWM outputs with individual control of all three pulse widths and positions.

Two match registers can be used to provide a single edge controlled PWM output. A dedicated match register controls the PWM cycle rate, by resetting the count upon match. The other match register controls the PWM edge position. Additional single edge controlled PWM outputs require only one match register each, since the repetition rate is the same for all PWM outputs. Multiple single edge controlled PWM outputs will all have a rising edge at the beginning of each PWM cycle, when an PWMMR0 match occurs.

Three match registers can be used to provide a PWM output with both edges controlled. Again, a dedicated match register controls the PWM cycle rate. The other match registers control the two PWM edge positions. Additional double edge controlled PWM outputs require only two match registers each, since the repetition rate is the same for all PWM outputs.

With double edge controlled PWM outputs, specific match registers control the rising and falling edge of the output. This allows both positive going PWM pulses (when the rising edge occurs prior to the falling edge), and negative going PWM pulses (when the falling edge occurs prior to the rising edge).

### 7.21.1 Features

- LPC2460 has two PWMs with the same operational features. These may be operated in a synchronized fashion by setting them both up to run at the same rate, then enabling both simultaneously. PWM0 acts as the master and PWM1 as the slave for this use.
- Counter or Timer operation (may use the peripheral clock or one of the capture inputs as the clock source).
- Seven match registers allow up to 6 single edge controlled or 3 double edge controlled PWM outputs, or a mix of both types. The match registers also allow:
  - Continuous operation with optional interrupt generation on match.
  - Stop timer on match with optional interrupt generation.
  - Reset timer on match with optional interrupt generation.
- Supports single edge controlled and/or double edge controlled PWM outputs. Single edge controlled PWM outputs all go high at the beginning of each cycle unless the output is a constant low. Double edge controlled PWM outputs can have either edge occur at any position within a cycle. This allows for both positive going and negative going pulses.

- Pulse period and width can be any number of timer counts. This allows complete flexibility in the trade-off between resolution and repetition rate. All PWM outputs will occur at the same repetition rate.
- Double edge controlled PWM outputs can be programmed to be either positive going or negative going pulses.
- Match register updates are synchronized with pulse outputs to prevent generation of erroneous pulses. Software must 'release' new match values before they can become effective.
- May be used as a standard timer if the PWM mode is not enabled.
- A 32-bit Timer/Counter with a programmable 32-bit Prescaler.

## 7.22 Watchdog timer (WDT)

The purpose of the watchdog is to reset the microcontroller within a reasonable amount of time if it enters an erroneous state. When enabled, the watchdog will generate a system reset if the user program fails to 'feed' (or reload) the watchdog within a predetermined amount of time.

### 7.22.1 Features

- Internally resets chip if not periodically reloaded.
- Debug mode.
- Enabled by software but requires a hardware reset or a watchdog reset/interrupt to be disabled.
- Incorrect/Incomplete feed sequence causes reset/interrupt if enabled.
- Flag to indicate watchdog reset.
- Programmable 32-bit timer with internal prescaler.
- Selectable time period from  $(T_{cy(WDCLK)} \times 256 \times 4)$  to  $(T_{cy(WDCLK)} \times 2^{32} \times 4)$  in multiples of  $T_{cy(WDCLK)} \times 4$ .
- The Watchdog Clock (WDCLK) source can be selected from the RTC clock, the Internal RC oscillator (IRC), or the APB peripheral clock. This gives a wide range of potential timing choices of Watchdog operation under different power reduction conditions. It also provides the ability to run the WDT from an entirely internal source that is not dependent on an external crystal and its associated components and wiring, for increased reliability.

## 7.23 RTC and battery RAM

The RTC is a set of counters for measuring time when system power is on, and optionally when it is off. It uses little power in Power-down mode. On the LPC2460, the RTC can be clocked by a separate 32.768 kHz oscillator or by a programmable prescale divider based on the APB clock. Also, the RTC is powered by its own power supply pin, VBAT, which can be connected to a battery or to the same 3.3 V supply used by the rest of the device.

The VBAT pin supplies power only to the RTC and the Battery RAM. These two functions require a minimum of power to operate, which can be supplied by an external battery. When the CPU and the rest of chip functions are stopped and power removed, the RTC can supply an alarm output that can be used by external hardware to restore chip power and resume operation.

### 7.23.1 Features

- Measures the passage of time to maintain a calendar and clock.
- Ultra low power design to support battery powered systems.
- Provides Seconds, Minutes, Hours, Day of Month, Month, Year, Day of Week, and Day of Year.
- Dedicated 32 kHz oscillator or programmable prescaler from APB clock.
- Dedicated power supply pin can be connected to a battery or to the main 3.3 V.
- An alarm output pin is included to assist in waking up when the chip has had power removed to all functions except the RTC and Battery RAM.
- Periodic interrupts can be generated from increments of any field of the time registers, and selected fractional second values. This enhancement enables the RTC to be used as a System Timer.
- 2 kB data SRAM powered by VBAT.
- RTC and Battery RAM power supply is isolated from the rest of the chip.

## 7.24 Clocking and power control

### 7.24.1 Crystal oscillators

The LPC2460 includes three independent oscillators. These are the Main Oscillator, the Internal RC oscillator, and the RTC oscillator. Each oscillator can be used for more than one purpose as required in a particular application. Any of the three clock sources can be chosen by software to drive the PLL and ultimately the CPU.

Following reset, the LPC2460 will operate from the Internal RC oscillator until switched by software. This allows systems to operate without any external crystal and the bootloader code to operate at a known frequency.

#### 7.24.1.1 Internal RC oscillator

The IRC may be used as the clock source for the WDT, and/or as the clock that drives the PLL and subsequently the CPU. The nominal IRC frequency is 4 MHz. The IRC is trimmed to 1 % accuracy.

Upon power-up or any chip reset, the LPC2460 uses the IRC as the clock source. Software may later switch to one of the other available clock sources.

#### 7.24.1.2 Main oscillator

The main oscillator can be used as the clock source for the CPU, with or without using the PLL. The main oscillator operates at frequencies of 1 MHz to 24 MHz. This frequency can be boosted to a higher frequency, up to the maximum CPU operating frequency, by the PLL. The clock selected as the PLL input is PLLCLKIN. The ARM processor clock frequency is referred to as CCLK elsewhere in this document. The frequencies of PLLCLKIN and CCLK are the same value unless the PLL is active and connected. The clock frequency for each peripheral can be selected individually and is referred to as PCLK. Refer to [Section 7.24.2](#) for additional information.

### 7.24.1.3 RTC oscillator

The RTC oscillator can be used as the clock source for the RTC and/or the WDT. Also, the RTC oscillator can be used to drive the PLL and the CPU.

### 7.24.2 PLL

The PLL accepts an input clock frequency in the range of 32 kHz to 50 MHz. The input frequency is multiplied up to a high frequency, then divided down to provide the actual clock used by the CPU and the USB block.

The PLL input, in the range of 32 kHz to 50 MHz, may initially be divided down by a value 'N', which may be in the range of 1 to 256. This input division provides a wide range of output frequencies from the same input frequency.

Following the PLL input divider is the PLL multiplier. This can multiply the input divider output through the use of a Current Controlled Oscillator (CCO) by a value 'M', in the range of 1 through 32768. The resulting frequency must be in the range of 275 MHz to 550 MHz. The multiplier works by dividing the CCO output by the value of M, then using a phase-frequency detector to compare the divided CCO output to the multiplier input. The error value is used to adjust the CCO frequency.

The PLL is turned off and bypassed following a chip Reset and by entering Power-down mode. PLL is enabled by software only. The program must configure and activate the PLL, wait for the PLL to lock, then connect to the PLL as a clock source.

### 7.24.3 Wake-up timer

The LPC2460 begins operation at power-up and when awakened from Power-down mode by using the 4 MHz IRC oscillator as the clock source. This allows chip operation to resume quickly. If the main oscillator or the PLL is needed by the application, software will need to enable these features and wait for them to stabilize before they are used as a clock source.

When the main oscillator is initially activated, the wake-up timer allows software to ensure that the main oscillator is fully functional before the processor uses it as a clock source and starts to execute instructions. This is important at power on, all types of Reset, and whenever any of the aforementioned functions are turned off for any reason. Since the oscillator and other functions are turned off during Power-down mode, any wake-up of the processor from Power-down mode makes use of the wake-up Timer.

The Wake-up Timer monitors the crystal oscillator to check whether it is safe to begin code execution. When power is applied to the chip, or when some event caused the chip to exit Power-down mode, some time is required for the oscillator to produce a signal of sufficient amplitude to drive the clock logic. The amount of time depends on many factors, including the rate of  $V_{DD(3V3)}$  ramp (in the case of power on), the type of crystal and its electrical characteristics (if a quartz crystal is used), as well as any other external circuitry (e.g., capacitors), and the characteristics of the oscillator itself under the existing ambient conditions.

### 7.24.4 Power control

The LPC2460 supports a variety of power control features. There are three special modes of processor power reduction: Idle mode, Sleep mode, and Power-down mode. The CPU clock rate may also be controlled as needed by changing clock sources, reconfiguring



PLL values, and/or altering the CPU clock divider value. This allows a trade-off of power versus processing speed based on application requirements. In addition, Peripheral power control allows shutting down the clocks to individual on-chip peripherals, allowing fine tuning of power consumption by eliminating all dynamic power use in any peripherals that are not required for the application. Each of the peripherals has its own clock divider which provides even better power control.

The LPC2460 also implements a separate power domain in order to allow turning off power to the bulk of the device while maintaining operation of the RTC and a small SRAM, referred to as the Battery RAM.

#### 7.24.4.1 Idle mode

In Idle mode, execution of instructions is suspended until either a Reset or interrupt occurs. Peripheral functions continue operation during Idle mode and may generate interrupts to cause the processor to resume execution. Idle mode eliminates dynamic power used by the processor itself, memory systems and related controllers, and internal buses.

#### 7.24.4.2 Sleep mode

In Sleep mode, the oscillator is shut down and the chip receives no internal clocks. The processor state and registers, peripheral registers, and internal SRAM values are preserved throughout Sleep mode and the logic levels of chip pins remain static. The output of the IRC is disabled but the IRC is not powered down for a fast wake-up later. The 32 kHz RTC oscillator is not stopped because the RTC interrupts may be used as the wake-up source. The PLL is automatically turned off and disconnected. The CCLK and USB clock dividers automatically get reset to zero.

The Sleep mode can be terminated and normal operation resumed by either a Reset or certain specific interrupts that are able to function without clocks. Since all dynamic operation of the chip is suspended, Sleep mode reduces chip power consumption to a very low value.

On the wake-up from Sleep mode, if the IRC was used before entering Sleep mode, the code execution and peripherals activities will resume after 4 cycles expire. If the main external oscillator was used, the code execution will resume when 4096 cycles expire.

The customers need to reconfigure the PLL and clock dividers accordingly.

#### 7.24.4.3 Power-down mode

Power-down mode does everything that Sleep mode does but also turns off the IRC oscillator.

On the wake-up from Power-down mode, if the IRC was used before entering Power-down mode, it will take IRC 60  $\mu$ s to start-up. After this 4 IRC cycles will expire before the code execution can then be resumed if the code was running from SRAM. The customers need to reconfigure the PLL and clock dividers accordingly after a wake-up from Power-down mode.

#### 7.24.4.4 Power domains

The LPC2460 provides two independent power domains that allow the bulk of the device to have power removed while maintaining operation of the RTC and the Battery RAM.

On the LPC2460, I/O pads are powered by the 3.3 V ( $V_{DD(3V3)}$ ) pins, while the  $V_{DD(DCDC)(3V3)}$  pins power the on-chip DC-to-DC converter which in turn provides power to the CPU and most of the peripherals.

Although both the I/O pad ring and the core require a 3.3 V supply, different powering schemes can be used depending on the actual application requirements.

The first option assumes that power consumption is not a concern and the design ties the  $V_{DD(3V3)}$  and  $V_{DD(DCDC)(3V3)}$  pins together. This approach requires only one 3.3 V power supply for both pads, the CPU, and peripherals. While this solution is simple, it does not support powering down the I/O pad ring “on the fly” while keeping the CPU and peripherals alive.

The second option uses two power supplies; a 3.3 V supply for the I/O pads ( $V_{DD(3V3)}$ ) and a dedicated 3.3 V supply for the CPU ( $V_{DD(DCDC)(3V3)}$ ). Having the on-chip DC-DC converter powered independently from the I/O pad ring enables shutting down of the I/O pad power supply “on the fly”, while the CPU and peripherals stay active.

The VBAT pin supplies power only to the RTC and the Battery RAM. These two functions require a minimum of power to operate, which can be supplied by an external battery. When the CPU and the rest of chip functions are stopped and power removed, the RTC can supply an alarm output that may be used by external hardware to restore chip power and resume operation.

## 7.25 System control

### 7.25.1 Reset

Reset has four sources on the LPC2460: the  $\overline{\text{RESET}}$  pin, the Watchdog reset, power-on reset, and the BrownOut Detection (BOD) circuit. The  $\overline{\text{RESET}}$  pin is a Schmitt trigger input pin. Assertion of chip Reset by any source, once the operating voltage attains a usable level, starts the Wake-up timer (see description in [Section 7.24.3 “Wake-up timer”](#)), causing reset to remain asserted until the external Reset is de-asserted, the oscillator is running, and a fixed number of clocks have passed.

Once the internal reset is removed, all of the processor and peripheral registers have been initialized to predetermined values and the LPC2460 continues with booting from an external static memory.

### 7.25.2 Boot process

The processor always boots from the off-chip static memory bank 1 executing code from address 0x8100 0000 (see [Table 5 “LPC2460 memory usage and details”](#)). During booting LPC2460’s EMC is configured to access external static memory using 16 data and 24 address lines. See [Section 11.2 “Suggested boot memory interface solutions”](#) for address and data bus interface details.

When booting from an external memory the interrupt vectors are mapped to the bottom of the external memory. Once booting is over the application must map interrupt vectors to the proper domain.

### 7.25.3 Brownout detection

The LPC2460 includes 2-stage monitoring of the voltage on the  $V_{DD(3V3)}$  pins. If this voltage falls below 2.95 V, the BOD asserts an interrupt signal to the Vectored Interrupt Controller. This signal can be enabled for interrupt in the Interrupt Enable Register in the VIC in order to cause a CPU interrupt; if not, software can monitor the signal by reading a dedicated status register.

The second stage of low-voltage detection asserts a BOD Reset and generates a Reset (if this reset source is enabled in software) to inactivate the LPC2460 when the voltage on the  $V_{DD(3V3)}$  pins falls below 2.65 V. The BOD circuit maintains this reset down below 1 V, at which point the power-on reset circuitry maintains the overall Reset.

Both the 2.95 V and 2.65 V thresholds include some hysteresis. In normal operation, this hysteresis allows the 2.95 V detection to reliably interrupt, or a regularly-executed event loop to sense the condition.

### 7.25.4 AHB bus

The LPC2460 implements two AHB buses in order to allow the Ethernet block to operate without interference caused by other system activity. The primary AHB, referred to as AHB1, includes the Vectored Interrupt Controller, GPDMA controller, USB interface, and 16 kB SRAM.

The second AHB, referred to as AHB2, includes only the Ethernet block and an associated 16 kB SRAM. In addition, a bus bridge is provided that allows the secondary AHB to be a bus master on AHB1, allowing expansion of Ethernet buffer space into off-chip memory or unused space in memory residing on AHB1.

In summary, bus masters with access to AHB1 are the ARM7 itself, the USB block, the GPDMA function, and the Ethernet block (via the bus bridge from AHB2). Bus masters with access to AHB2 are the ARM7 and the Ethernet block.

### 7.25.5 External interrupt inputs

The LPC2460 includes up to 68 edge sensitive interrupt inputs combined with up to four level sensitive external interrupt inputs as selectable pin functions. The external interrupt inputs can optionally be used to wake up the processor from Power-down mode.

### 7.25.6 Memory mapping control

The memory mapping control alters the mapping of the interrupt vectors that appear at the beginning at address 0x0000 0000. Vectors may be mapped to the bottom of the Boot ROM, the SRAM, or external memory. This allows code running in different memory spaces to have control of the interrupts.

## 7.26 Emulation and debugging

The LPC2460 support emulation and debugging via a JTAG serial port. A trace port allows tracing program execution. Debugging and trace functions are multiplexed only with GPIOs on P2[0] to P2[9]. This means that all communication, timer, and interface peripherals residing on other pins are available during the development and debugging phase as they are when the application is run in the embedded system itself.

### 7.26.1 EmbeddedICE

The EmbeddedICE logic provides on-chip debug support. The debugging of the target system requires a host computer running the debugger software and an EmbeddedICE protocol convertor. The EmbeddedICE protocol convertor converts the Remote Debug Protocol commands to the JTAG data needed to access the ARM7TDMI-S core present on the target system.

The ARM core has a Debug Communication Channel (DCC) function built-in. The DCC allows a program running on the target to communicate with the host debugger or another separate host without stopping the program flow or even entering the debug state. The DCC is accessed as a coprocessor 14 by the program running on the ARM7TDMI-S core. The DCC allows the JTAG port to be used for sending and receiving data without affecting the normal program flow. The DCC data and control registers are mapped in to addresses in the EmbeddedICE logic.

The JTAG clock (TCK) must be slower than  $\frac{1}{6}$  of the CPU clock (CCLK) for the JTAG interface to operate.

### 7.26.2 Embedded trace

Since the LPC2460 have significant amounts of on-chip memories, it is not possible to determine how the processor core is operating simply by observing the external pins. The ETM provides real-time trace capability for deeply embedded processor cores. It outputs information about processor execution to a trace port. A software debugger allows configuration of the ETM using a JTAG interface and displays the trace information that has been captured.

The ETM is connected directly to the ARM core and not to the main AMBA system bus. It compresses the trace information and exports it through a narrow trace port. An external Trace Port Analyzer captures the trace information under software debugger control. The trace port can broadcast the Instruction trace information. Instruction trace (or PC trace) shows the flow of execution of the processor and provides a list of all the instructions that were executed. Instruction trace is significantly compressed by only broadcasting branch addresses as well as a set of status signals that indicate the pipeline status on a cycle by cycle basis. Trace information generation can be controlled by selecting the trigger resource. Trigger resources include address comparators, counters and sequencers. Since trace information is compressed the software debugger requires a static image of the code being executed. Self-modifying code can not be traced because of this restriction.

### 7.26.3 RealMonitor

RealMonitor is a configurable software module, developed by ARM Inc., which enables real-time debug. It is a lightweight debug monitor that runs in the background while users debug their foreground application. It communicates with the host using the DCC, which is present in the EmbeddedICE logic. The LPC2460 contain a specific configuration of RealMonitor software programmed into the on-chip ROM memory.

## 8. Limiting values

**Table 6. Limiting values**

In accordance with the Absolute Maximum Rating System (IEC 60134).<sup>[1]</sup>

Symbol	Parameter	Conditions	Min	Max	Unit
$V_{DD(3V3)}$	supply voltage (3.3 V)	core and external rail	3.0	3.6	V
$V_{DD(DCDC)(3V3)}$	DC-to-DC converter supply voltage (3.3 V)		3.0	3.6	V
$V_{DDA}$	analog 3.3 V pad supply voltage		-0.5	+4.6	V
$V_{i(VBAT)}$	input voltage on pin VBAT	for the RTC	-0.5	+4.6	V
$V_{i(VREF)}$	input voltage on pin VREF		-0.5	+4.6	V
$V_{IA}$	analog input voltage	on ADC related pins	-0.5	+5.1	V
$V_I$	input voltage	5 V tolerant I/O pins; only valid when the $V_{DD(3V3)}$ supply voltage is present	<sup>[2]</sup> -0.5	+6.0	V
		other I/O pins	<sup>[2][3]</sup> -0.5	$V_{DD(3V3)} + 0.5$	V
$I_{DD}$	supply current	per supply pin	<sup>[4]</sup> -	100	mA
$I_{SS}$	ground current	per ground pin	<sup>[4]</sup> -	100	mA
$T_{stg}$	storage temperature		<sup>[5]</sup> -65	+150	°C
$P_{tot(pack)}$	total power dissipation (per package)	based on package heat transfer, not device power consumption	-	1.5	W
$V_{esd}$	electrostatic discharge voltage	human body model; all pins	<sup>[6]</sup> -2000	+2000	V

[1] The following applies to the Limiting values:

- a) This product includes circuitry specifically designed for the protection of its internal devices from the damaging effects of excessive static charge. Nonetheless, it is suggested that conventional precautions be taken to avoid applying greater than the rated maximum.
- b) Parameters are valid over operating temperature range unless otherwise specified. All voltages are with respect to  $V_{SS}$  unless otherwise noted.

[2] Including voltage on outputs in 3-state mode.

[3] Not to exceed 4.6 V.

[4] The peak current is limited to 25 times the corresponding maximum current.

[5] Dependent on package type.

[6] Human body model: equivalent to discharging a 100 pF capacitor through a 1.5 kΩ series resistor.

## 9. Static characteristics

**Table 7. Static characteristics**

$T_{amb} = -40\text{ °C}$  to  $+85\text{ °C}$  for commercial applications, unless otherwise specified.

Symbol	Parameter	Conditions	Min	Typ <sup>[1]</sup>	Max	Unit
$V_{DD(3V3)}$	supply voltage (3.3 V)	core and external rail	3.0	3.3	3.6	V
$V_{DD(DCDC)(3V3)}$	DC-to-DC converter supply voltage (3.3 V)		3.0	3.3	3.6	V
$V_{DDA}$	analog 3.3 V pad supply voltage		3.0	3.3	3.6	V
$V_{I(VBAT)}$	input voltage on pin VBAT		[2] 2.0	3.3	3.6	V
$V_{I(VREF)}$	input voltage on pin VREF		2.5	3.3	$V_{DDA}$	V
<b>Standard port pins, RESET, RTCK</b>						
$I_{IL}$	LOW-level input current	$V_I = 0\text{ V}$ ; no pull-up	-	-	3	$\mu\text{A}$
$I_{IH}$	HIGH-level input current	$V_I = V_{DD(3V3)}$ ; no pull-down	-	-	3	$\mu\text{A}$
$I_{OZ}$	OFF-state output current	$V_O = 0\text{ V}$ ; $V_O = V_{DD(3V3)}$ ; no pull-up/down	-	-	3	$\mu\text{A}$
$I_{latch}$	I/O latch-up current	$-(0.5V_{DD(3V3)}) < V_I < (1.5V_{DD(3V3)})$ ; $T_j < 125\text{ °C}$	-	-	100	mA
$V_I$	input voltage	pin configured to provide a digital function	[3][4][5] 0	-	5.5	V
$V_O$	output voltage	output active	0	-	$V_{DD(3V3)}$	V
$V_{IH}$	HIGH-level input voltage		2.0	-	-	V
$V_{IL}$	LOW-level input voltage		-	-	0.8	V
$V_{hys}$	hysteresis voltage		-	0.4	-	V
$V_{OH}$	HIGH-level output voltage	$I_{OH} = -4\text{ mA}$	[6] $V_{DD(3V3)} - 0.4$	-	-	V
$V_{OL}$	LOW-level output voltage	$I_{OL} = -4\text{ mA}$	[6] -	-	0.4	V
$I_{OH}$	HIGH-level output current	$V_{OH} = V_{DD(3V3)} - 0.4\text{ V}$	[6] -4	-	-	mA
$I_{OL}$	LOW-level output current	$V_{OL} = 0.4\text{ V}$	[6] 4	-	-	mA
$I_{OHS}$	HIGH-level short-circuit output current	$V_{OH} = 0\text{ V}$	[7] -	-	-45	mA
$I_{OLS}$	LOW-level short-circuit output current	$V_{OL} = V_{DDA}$	[7] -	-	50	mA
$I_{pd}$	pull-down current	$V_I = 5\text{ V}$	[8] 10	50	150	$\mu\text{A}$
$I_{pu}$	pull-up current	$V_I = 0\text{ V}$	-15	-50	-85	$\mu\text{A}$
		$V_{DD(3V3)} < V_I < 5\text{ V}$	[8] 0	0	0	$\mu\text{A}$

**Table 7. Static characteristics ...continued**

$T_{amb} = -40\text{ }^{\circ}\text{C}$  to  $+85\text{ }^{\circ}\text{C}$  for commercial applications, unless otherwise specified.

Symbol	Parameter	Conditions	Min	Typ <sup>[1]</sup>	Max	Unit	
$I_{DD(DCDC)act(3V3)}$	active mode DC-to-DC converter supply current (3.3 V)	$V_{DD(DCDC)(3V3)} = 3.3\text{ V}$ ; $T_{amb} = 25\text{ }^{\circ}\text{C}$ ; code while(1){}					
		executed from the on-chip SRAM; no peripherals enabled; PCLK = CCLK					
		CCLK = 10 MHz	-	<tdb>	-	mA	
		CCLK = 72 MHz	-	<tdb>	-	mA	
		all peripherals enabled; PCLK = CCLK / 8					
		CCLK = 10 MHz	-	<tdb>	-	mA	
		CCLK = 72 MHz	-	<tdb>	-	mA	
		all peripherals enabled; PCLK = CCLK					
		CCLK = 10 MHz	-	<tdb>	-	mA	
		CCLK = 72 MHz	-	<tdb>	-	mA	
$I_{DD(DCDC)pd(3V3)}$	power-down mode DC-to-DC converter supply current (3.3 V)	$V_{DD(DCDC)(3V3)} = 3.3\text{ V}$ ; $T_{amb} = 25\text{ }^{\circ}\text{C}$	-	150	-	$\mu\text{A}$	
$I_{BATact}$	active mode battery supply current	DC-to-DC converter on	<a href="#">[9]</a>	-	20	-	$\mu\text{A}$
		DC-to-DC converter off	<a href="#">[9]</a>	-	28	-	$\mu\text{A}$
<b>I<sup>2</sup>C-bus pins (P0[27] and P0[28])</b>							
$V_{IH}$	HIGH-level input voltage		$0.7V_{DD(3V3)}$	-	-	V	
$V_{IL}$	LOW-level input voltage		-	-	$0.3V_{DD(3V3)}$	V	
$V_{hys}$	hysteresis voltage		-	$0.5V_{DD(3V3)}$	-	V	
$V_{OL}$	LOW-level output voltage	$I_{OLS} = 3\text{ mA}$	<a href="#">[6]</a>	-	0.4	V	
$I_{LI}$	input leakage current	$V_I = V_{DD(3V3)}$	<a href="#">[10]</a>	-	2	4	$\mu\text{A}$
		$V_I = 5\text{ V}$	-	-	10	22	$\mu\text{A}$
<b>Oscillator pins</b>							
$V_{i(XTAL1)}$	input voltage on pin XTAL1		0	-	1.8	V	
$V_{o(XTAL2)}$	output voltage on pin XTAL2		0	-	1.8	V	
$V_{i(RTCX1)}$	input voltage on pin RTCX1		0	-	1.8	V	
$V_{o(RTCX2)}$	output voltage on pin RTCX2		0	-	1.8	V	
<b>USB pins</b>							
$I_{OZ}$	OFF-state output current	$0\text{ V} < V_I < 3.3\text{ V}$	-	-	$\pm 10$	$\mu\text{A}$	
$V_{BUS}$	bus supply voltage		-	-	5.25	V	

**Table 7. Static characteristics ...continued**

$T_{amb} = -40\text{ }^{\circ}\text{C}$  to  $+85\text{ }^{\circ}\text{C}$  for commercial applications, unless otherwise specified.

Symbol	Parameter	Conditions	Min	Typ <sup>[1]</sup>	Max	Unit
V <sub>DI</sub>	differential input sensitivity	(D+) – (D–)	0.2	-	-	V
V <sub>CM</sub>	differential common mode voltage range	includes V <sub>DI</sub> range	0.8	-	2.5	V
V <sub>th(rs)se</sub>	single-ended receiver switching threshold voltage		0.8	-	2.0	V
V <sub>OL</sub>	LOW-level output voltage for low-/full-speed	R <sub>L</sub> of 1.5 kΩ to 3.6 V	-	-	0.18	V
V <sub>OH</sub>	HIGH-level output voltage (driven) for low-/full-speed	R <sub>L</sub> of 15 kΩ to GND	2.8	-	3.5	V
C <sub>trans</sub>	transceiver capacitance	pin to GND	-	-	20	pF
Z <sub>DRV</sub>	driver output impedance for driver which is not high-speed capable	with 33 Ω series resistor; steady state drive	[11] 36	-	44.1	Ω
R <sub>pu</sub>	pull-up resistance	SoftConnect = ON	1.1	-	1.9	kΩ

- [1] Typical ratings are not guaranteed. The values listed are at room temperature (25 °C), nominal supply voltages
- [2] The RTC typically fails when V<sub>i(VBAT)</sub> drops below 1.6 V.
- [3] Including voltage on outputs in 3-state mode.
- [4] V<sub>DD(3V3)</sub> supply voltages must be present.
- [5] 3-state outputs go into 3-state mode when V<sub>DD(3V3)</sub> is grounded.
- [6] Accounts for 100 mV voltage drop in all supply lines.
- [7] Only allowed for a short time period.
- [8] Minimum condition for V<sub>I</sub> = 4.5 V, maximum condition for V<sub>I</sub> = 5.5 V.
- [9] On pin VBAT.
- [10] To V<sub>SS</sub>.
- [11] Includes external resistors of 18 Ω ± 1 % on D+ and D–.

**Table 8. ADC static characteristics**

V<sub>DDA</sub> = 2.5 V to 3.6 V;  $T_{amb} = -40\text{ }^{\circ}\text{C}$  to  $+85\text{ }^{\circ}\text{C}$  unless otherwise specified; ADC frequency 4.5 MHz.

Symbol	Parameter	Conditions	Min	Typ	Max	Unit
V <sub>IA</sub>	analog input voltage		0	-	V <sub>DDA</sub>	V
C <sub>ia</sub>	analog input capacitance		-	-	1	pF
E <sub>D</sub>	differential linearity error		[1][2][3] -	-	±1	LSB
E <sub>L(adj)</sub>	integral non-linearity		[1][4] -	-	±2	LSB
E <sub>O</sub>	offset error		[1][5] -	-	±3	LSB
E <sub>G</sub>	gain error		[1][6] -	-	±0.5	%
E <sub>T</sub>	absolute error		[1][7] -	-	±4	LSB
R <sub>vsi</sub>	voltage source interface resistance		[8] -	-	40	kΩ



- [1] Conditions:  $V_{SSA} = 0\text{ V}$ ,  $V_{DDA} = 3.3\text{ V}$ .
- [2] The ADC is monotonic, there are no missing codes.
- [3] The differential linearity error ( $E_D$ ) is the difference between the actual step width and the ideal step width. See [Figure 5](#).
- [4] The integral non-linearity ( $E_{L(\text{adj})}$ ) is the peak difference between the center of the steps of the actual and the ideal transfer curve after appropriate adjustment of gain and offset errors. See [Figure 5](#).
- [5] The offset error ( $E_O$ ) is the absolute difference between the straight line which fits the actual curve and the straight line which fits the ideal curve. See [Figure 5](#).
- [6] The gain error ( $E_G$ ) is the relative difference in percent between the straight line fitting the actual transfer curve after removing offset error, and the straight line which fits the ideal transfer curve. See [Figure 5](#).
- [7] The absolute error ( $E_T$ ) is the maximum difference between the center of the steps of the actual transfer curve of the non-calibrated ADC and the ideal transfer curve. See [Figure 5](#).
- [8] See [Figure 6](#).

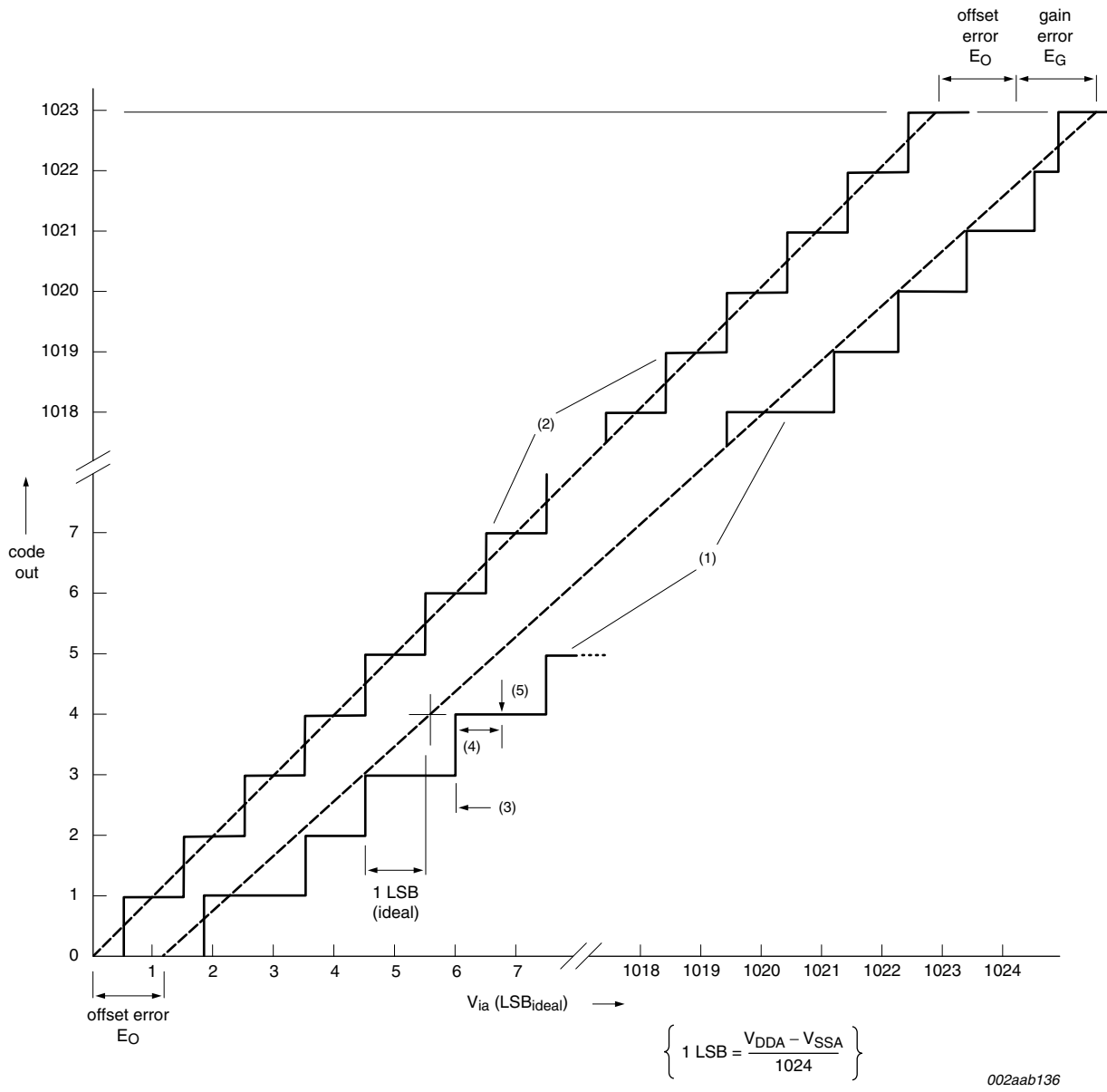

002aab136

- (1) Example of an actual transfer curve.
- (2) The ideal transfer curve.
- (3) Differential linearity error (E<sub>D</sub>).
- (4) Integral non-linearity (E<sub>L(adj)</sub>).
- (5) Center of a step of the actual transfer curve.

**Fig 5. ADC characteristics**

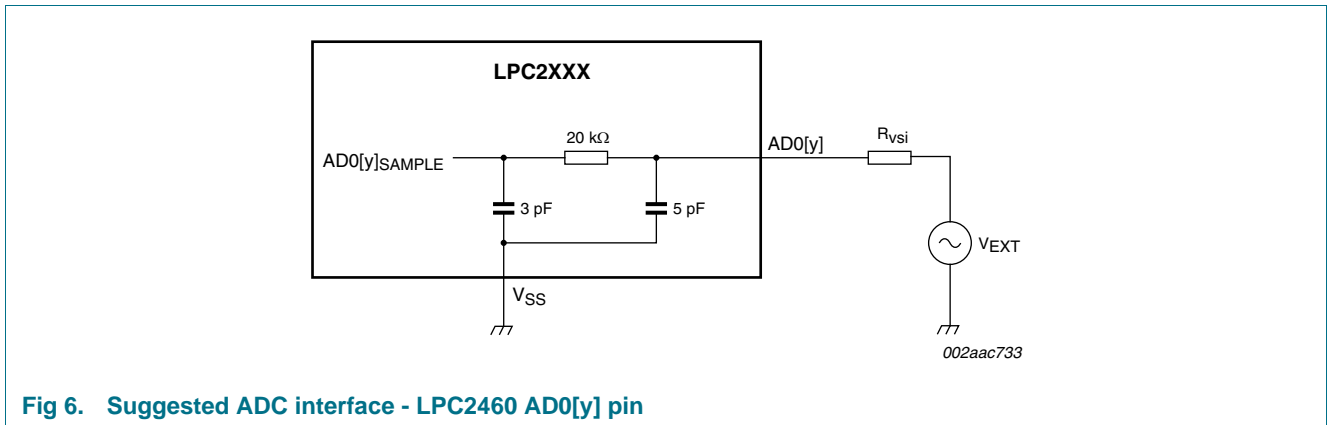

Fig 6. Suggested ADC interface - LPC2460 AD0[y] pin

## 10. Dynamic characteristics

**Table 9. Dynamic characteristics of USB pins (full-speed)**

$C_L = 50\text{ pF}$ ;  $R_{pu} = 1.5\text{ k}\Omega$  on D+ to  $V_{DD(3V3)}$ , unless otherwise specified.

Symbol	Parameter	Conditions	Min	Typ	Max	Unit
$t_r$	rise time	10 % to 90 %	8.5	-	13.8	ns
$t_f$	fall time	10 % to 90 %	7.7	-	13.7	ns
$t_{FRFM}$	differential rise and fall time matching	$t_r / t_f$	-	-	109	%
$V_{CRS}$	output signal crossover voltage		1.3	-	2.0	V
$t_{FEOPT}$	source SE0 interval of EOP	see <a href="#">Figure 8</a>	160	-	175	ns
$t_{FDEOP}$	source jitter for differential transition to SE0 transition	see <a href="#">Figure 8</a>	-2	-	+5	ns
$t_{JR1}$	receiver jitter to next transition		-18.5	-	+18.5	ns
$t_{JR2}$	receiver jitter for paired transitions	10 % to 90 %	-9	-	+9	ns
$t_{EOPR1}$	EOP width at receiver	must reject as EOP; see <a href="#">Figure 8</a>	[1] 40	-	-	ns
$t_{EOPR2}$	EOP width at receiver	must accept as EOP; see <a href="#">Figure 8</a>	[1] 82	-	-	ns

[1] Characterized but not implemented as production test. Guaranteed by design.

**Table 10. Dynamic characteristics**

$T_{amb} = -40\text{ °C}$  to  $+85\text{ °C}$  for commercial applications;  $V_{DD(3V3)}$  over specified ranges.<sup>[1]</sup>

Symbol	Parameter	Conditions	Min	Typ <sup>[2]</sup>	Max	Unit
<b>External clock</b>						
$f_{osc}$	oscillator frequency		1	-	24	MHz
$T_{cy(clk)}$	clock cycle time		42	-	1000	ns
$t_{CHCX}$	clock HIGH time		$T_{cy(clk)} \times 0.4$	-	-	ns
$t_{CLCX}$	clock LOW time		$T_{cy(clk)} \times 0.4$	-	-	ns
$t_{CLCH}$	clock rise time		-	-	5	ns
$t_{CHCL}$	clock fall time		-	-	5	ns
<b>I<sup>2</sup>C-bus pins (P0[27] and P0[28])</b>						
$t_{f(o)}$	output fall time	$V_{IH}$ to $V_{IL}$	$20 + 0.1 \times C_b$ <sup>[3]</sup>	-	-	ns
<b>SSP interface</b>						
$t_{su(SPI\_MISO)}$	SPI_MISO set-up time	$T_{amb} = 25\text{ °C}$ ; <i>measured in SPI Master mode; see Figure 9</i>	-	11	-	ns

- [1] Parameters are valid over operating temperature range unless otherwise specified.
- [2] Typical ratings are not guaranteed. The values listed are at room temperature (25 °C), nominal supply voltages.
- [3] Bus capacitance  $C_b$  in pF, from 10 pF to 400 pF.

10.1 Timing

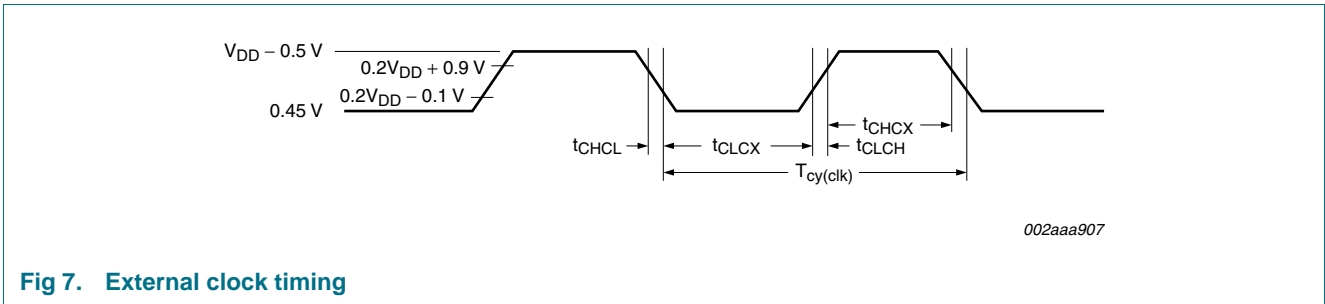

Fig 7. External clock timing

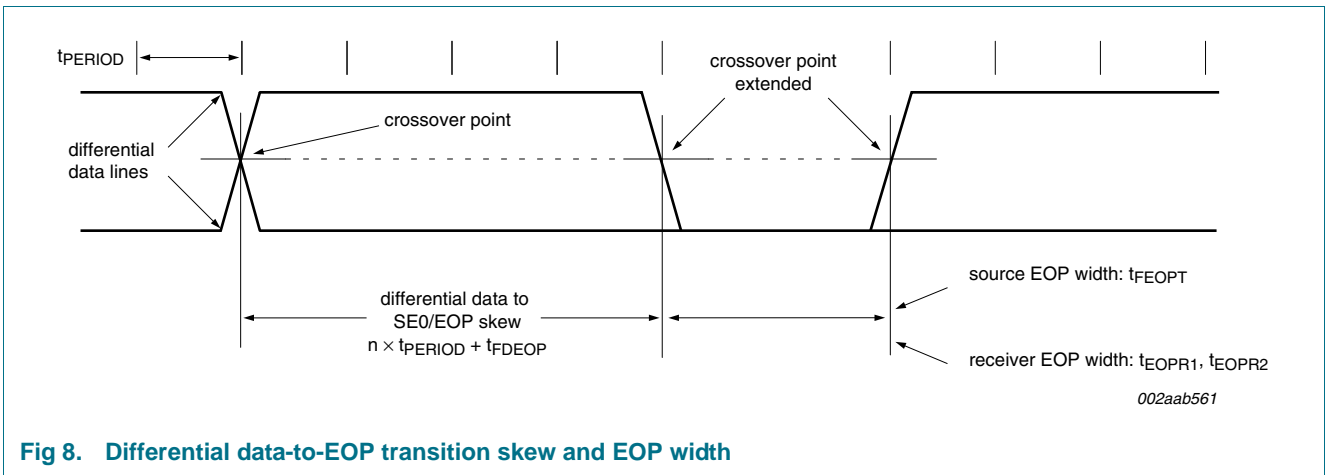

Fig 8. Differential data-to-EOP transition skew and EOP width

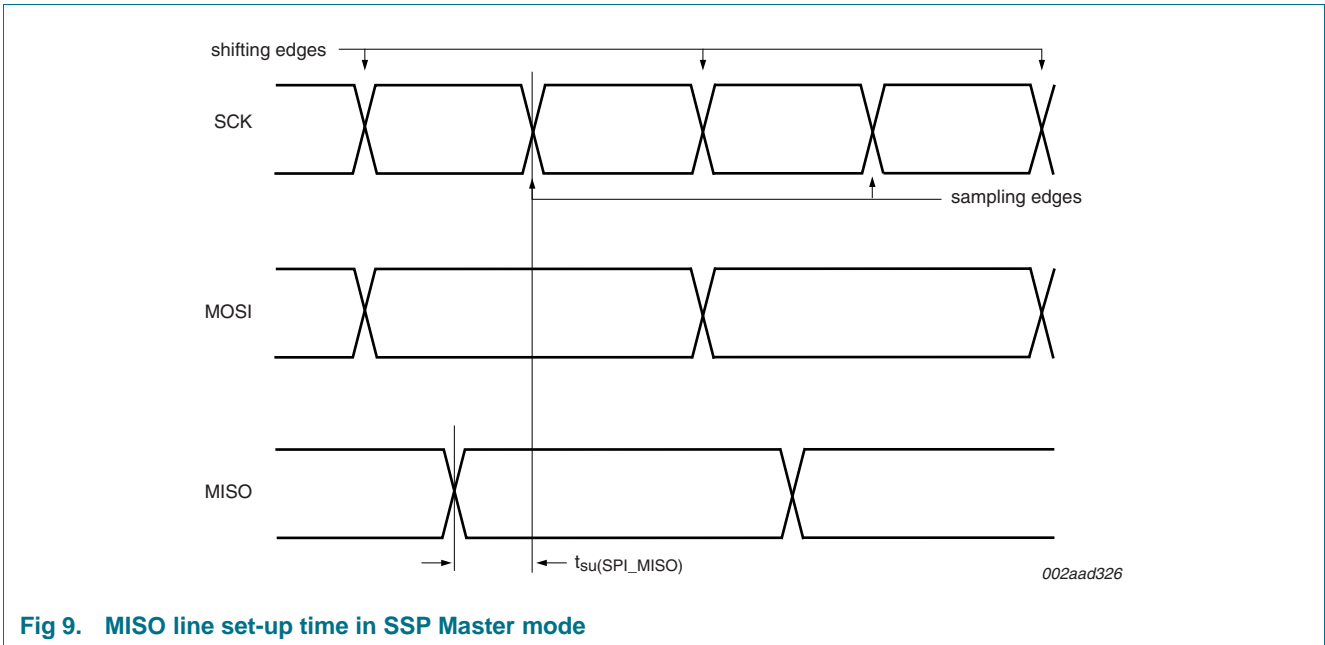

Fig 9. MISO line set-up time in SSP Master mode

## 11. Application information

### 11.1 Suggested USB interface solutions

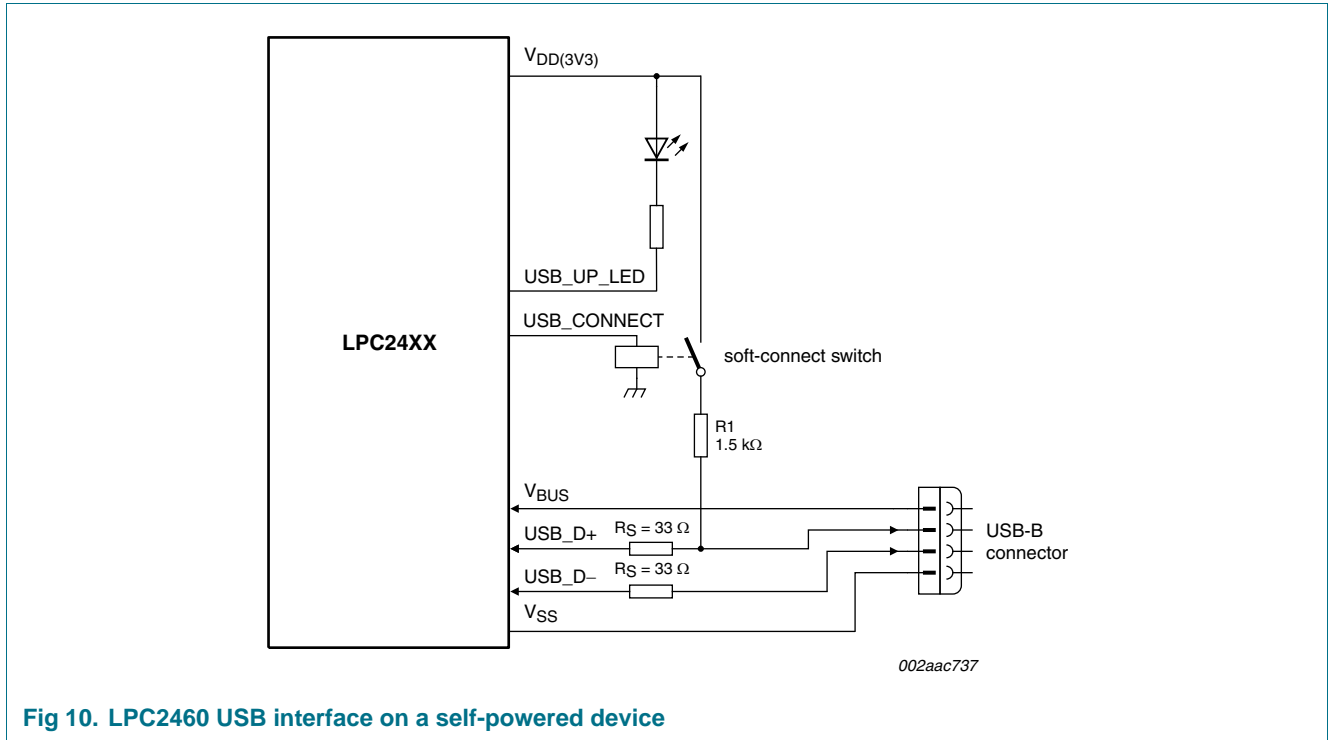

Fig 10. LPC2460 USB interface on a self-powered device

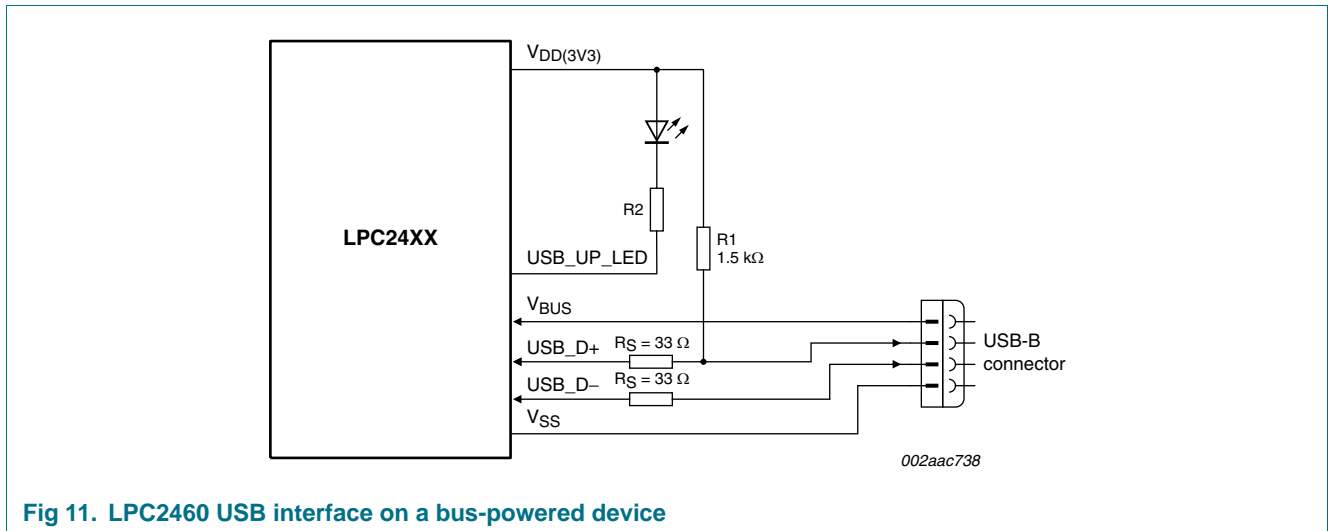

Fig 11. LPC2460 USB interface on a bus-powered device

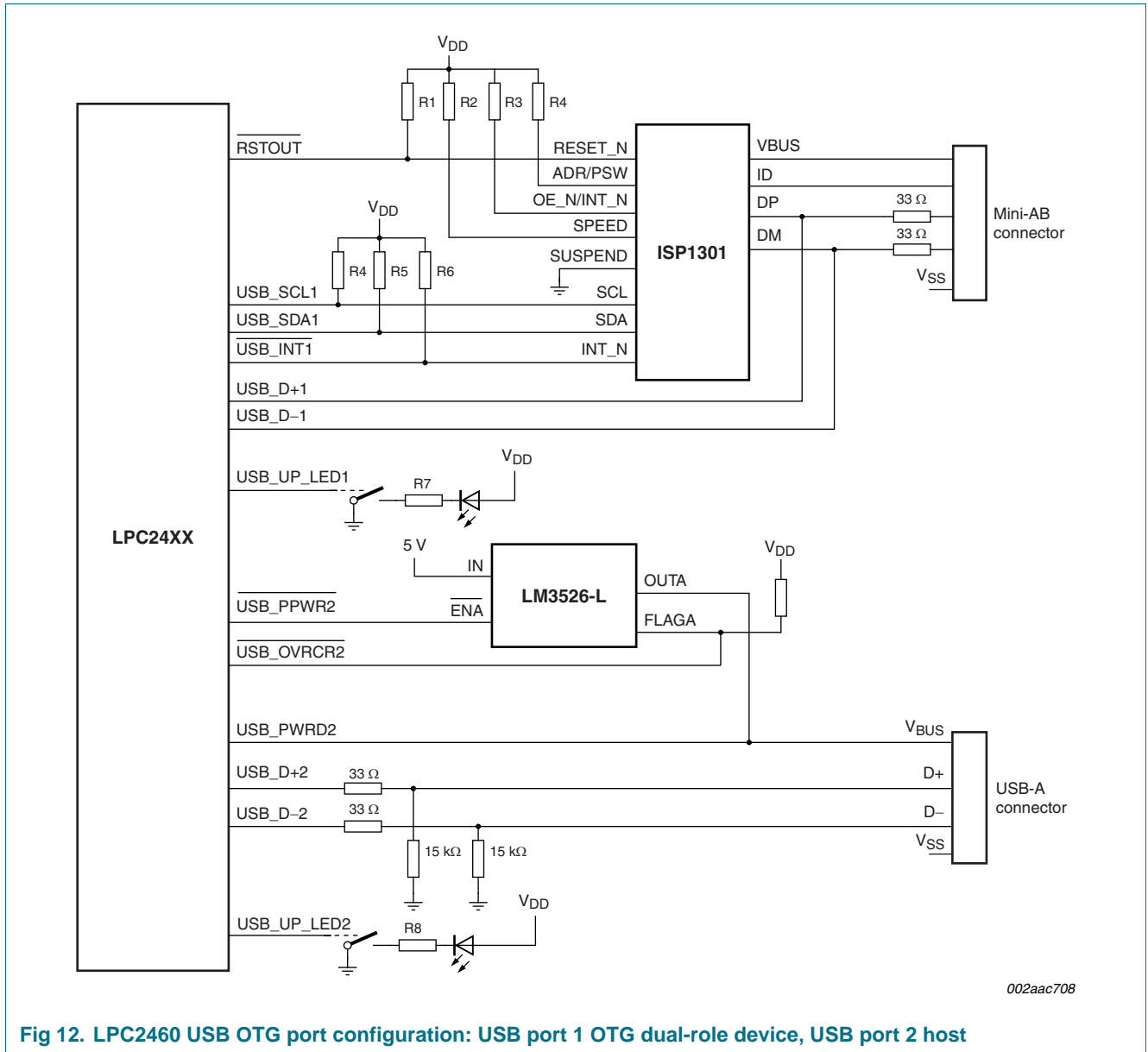

Fig 12. LPC2460 USB OTG port configuration: USB port 1 OTG dual-role device, USB port 2 host





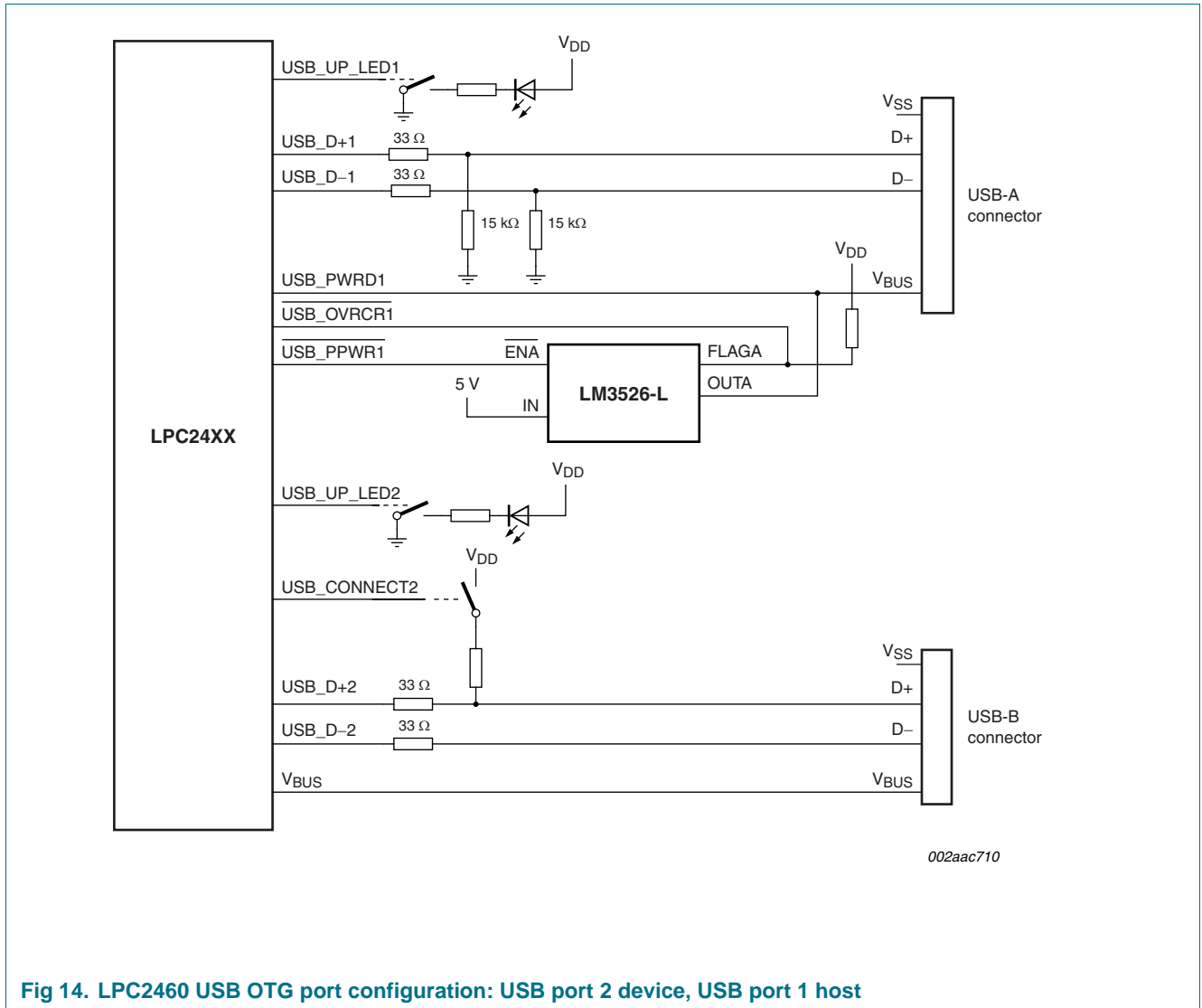

Fig 14. LPC2460 USB OTG port configuration: USB port 2 device, USB port 1 host

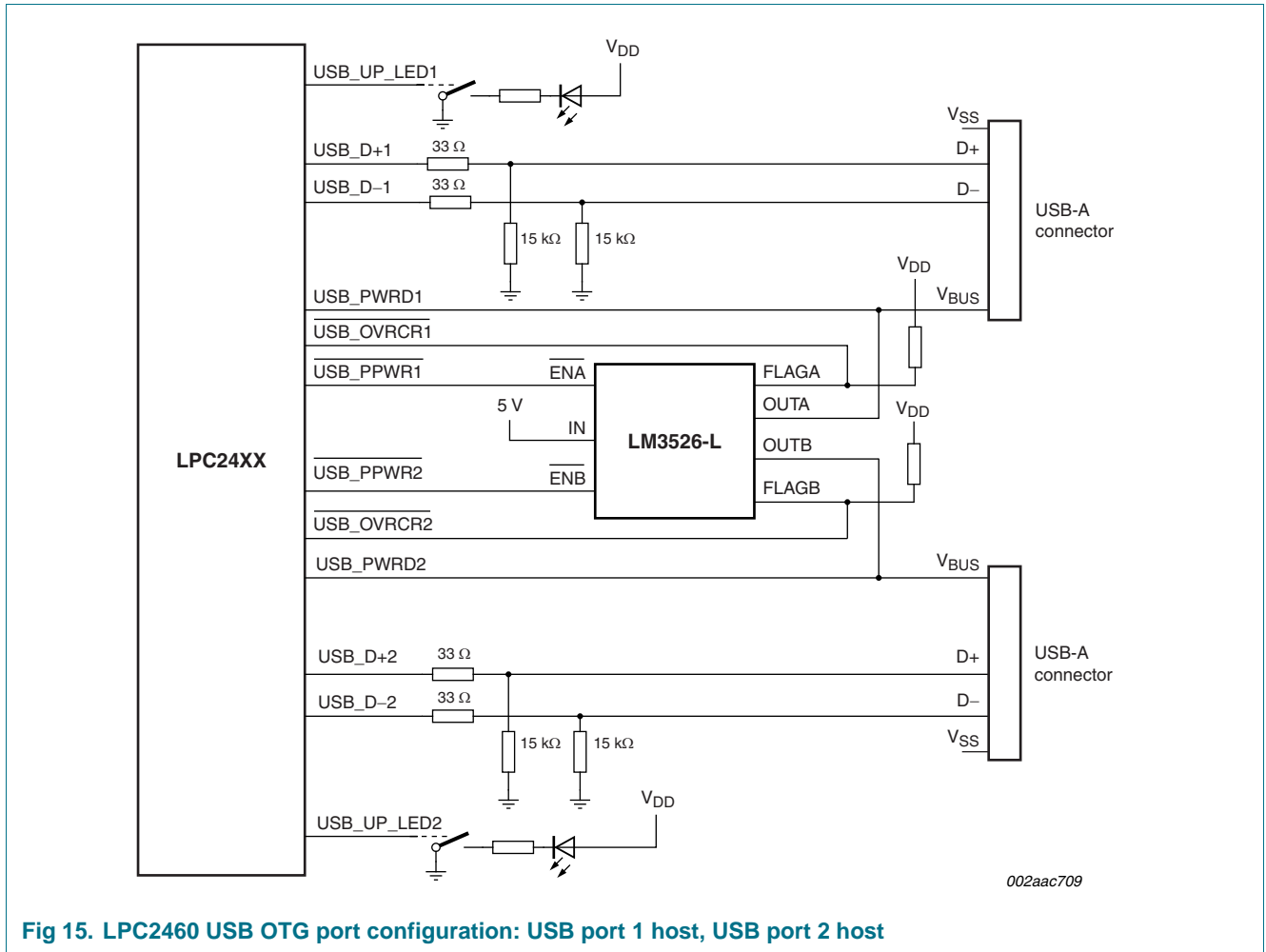

Fig 15. LPC2460 USB OTG port configuration: USB port 1 host, USB port 2 host

### 11.2 Suggested boot memory interface solutions

“a\_m” and “a\_b” in the following figures refer to the highest order address line of the memory chip and the highest order microcontroller’s address line used respectively.

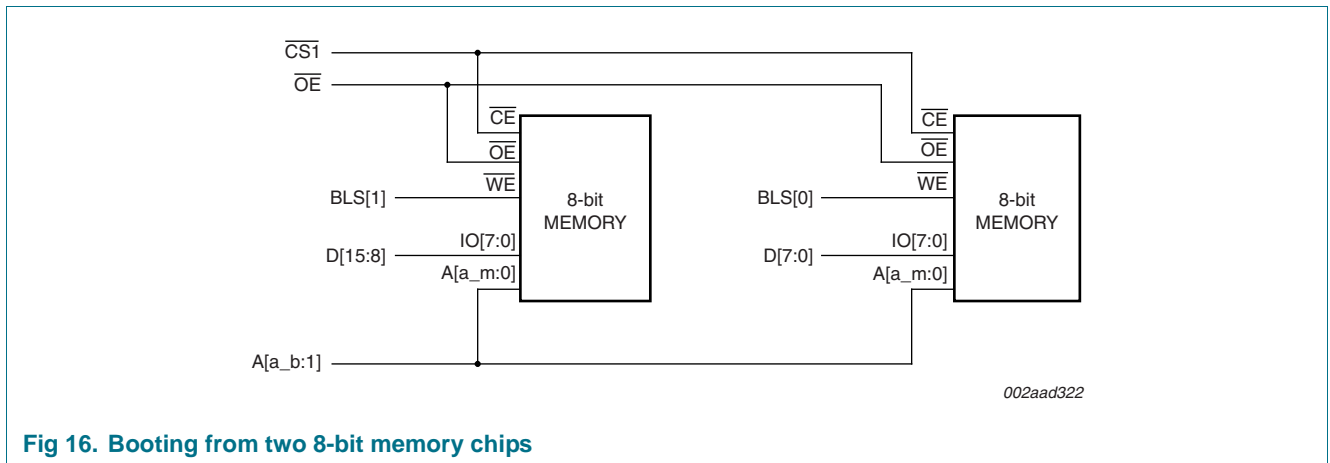

Fig 16. Booting from two 8-bit memory chips

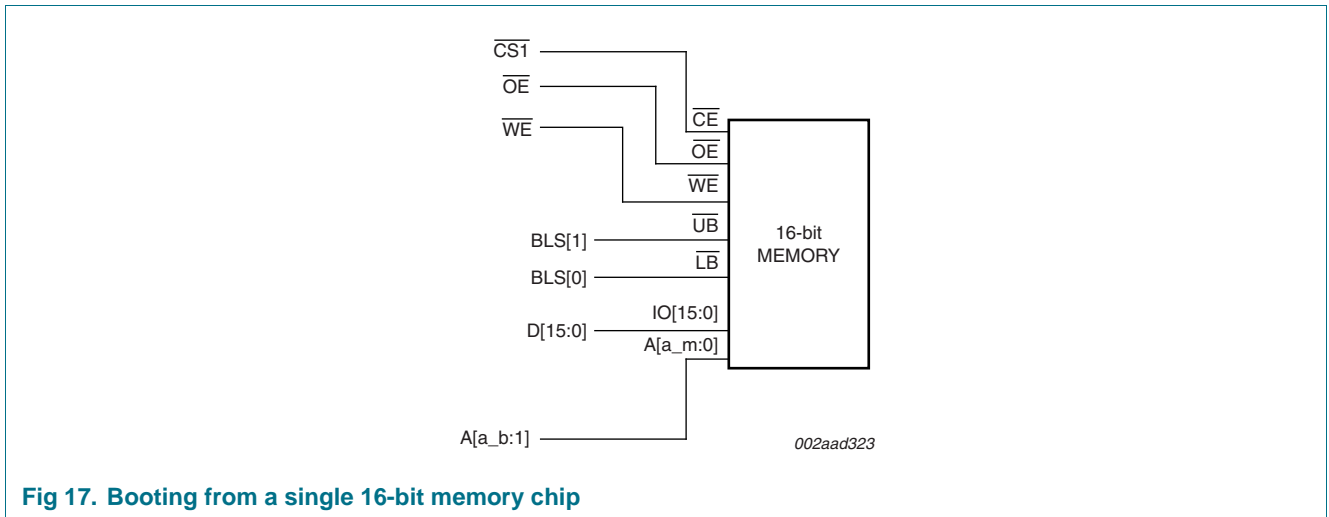

Fig 17. Booting from a single 16-bit memory chip

12. Package outline

LQFP208; plastic low profile quad flat package; 208 leads; body 28 x 28 x 1.4 mm

SOT459-1

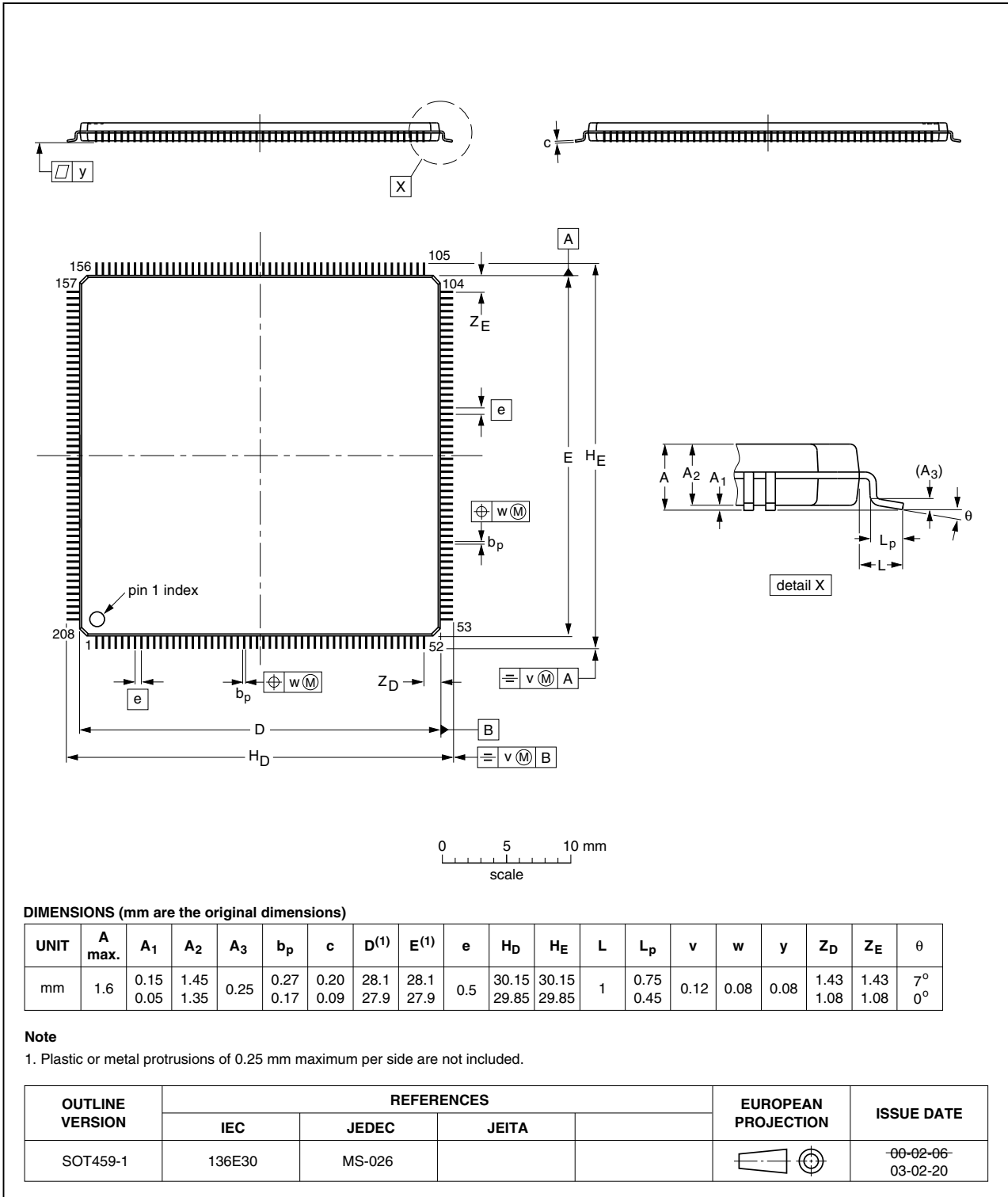

Fig 18. Package outline SOT459-1 (LQFP208)

TFBGA208: plastic thin fine-pitch ball grid array package; 208 balls; body 15 x 15 x 0.7 mm

SOT950-1

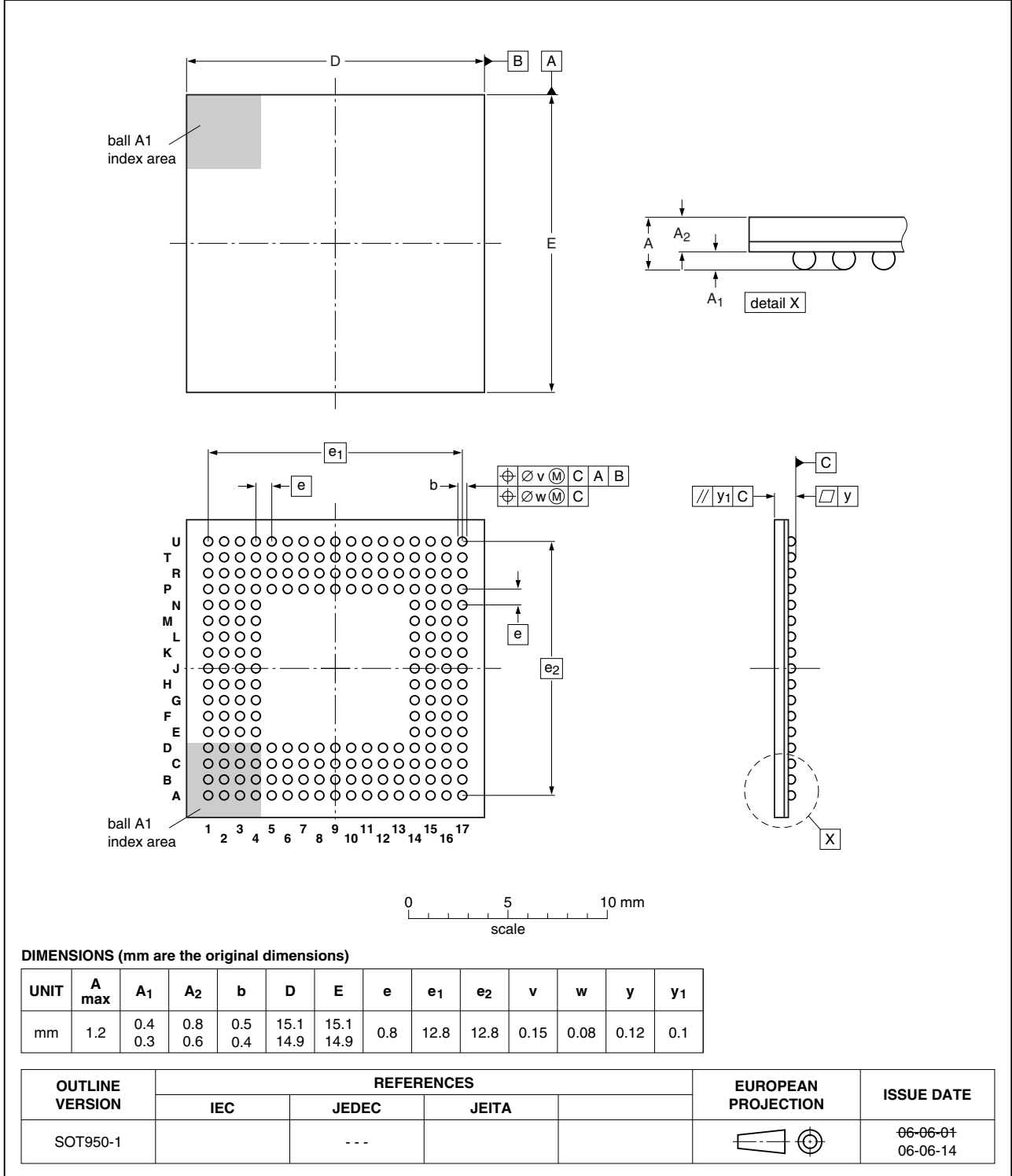

Fig 19. Package outline SOT950-1 (TFBGA208)

## 13. Abbreviations

**Table 11. Acronym list**

<b>Acronym</b>	<b>Description</b>
ADC	Analog-to-Digital Converter
AHB	Advanced High-performance Bus
AMBA	Advanced Microcontroller Bus Architecture
APB	Advanced Peripheral Bus
ATX	Analog Transceiver
BLS	Byte Lane Select
BOD	BrownOut Detection
CAN	Controller Area Network
DAC	Digital-to-Analog Converter
DCC	Debug Communication Channel
DMA	Direct Memory Access
DSP	Digital Signal Processing
EOP	End Of Packet
ETM	Embedded Trace Macrocell
GPIO	General Purpose Input/Output
IrDA	Infrared Data Association
JTAG	Joint Test Action Group
MII	Media Independent Interface
PHY	Physical Layer
PLL	Phase-Locked Loop
PWM	Pulse Width Modulator
RMII	Reduced Media Independent Interface
SD/MMC	Secure Digital/MultiMediaCard
SE0	Single Ended Zero
SPI	Serial Peripheral Interface
SSI	Synchronous Serial Interface
SSP	Synchronous Serial Port
TTL	Transistor-Transistor Logic
UART	Universal Asynchronous Receiver/Transmitter
USB	Universal Serial Bus

## 14. Revision history

Table 12. Revision history

Document ID	Release date	Data sheet status	Change notice	Supersedes
LPC2460_0.01	<td>	Preliminary		



## 15. Legal information

### 15.1 Data sheet status

Document status <sup>[1][2]</sup>	Product status <sup>[3]</sup>	Definition
Objective [short] data sheet	Development	This document contains data from the objective specification for product development.
Preliminary [short] data sheet	Qualification	This document contains data from the preliminary specification.
Product [short] data sheet	Production	This document contains the product specification.

[1] Please consult the most recently issued document before initiating or completing a design.

[2] The term 'short data sheet' is explained in section "Definitions".

[3] The product status of device(s) described in this document may have changed since this document was published and may differ in case of multiple devices. The latest product status information is available on the Internet at URL <http://www.nxp.com>.

### 15.2 Definitions

**Draft** — The document is a draft version only. The content is still under internal review and subject to formal approval, which may result in modifications or additions. NXP Semiconductors does not give any representations or warranties as to the accuracy or completeness of information included herein and shall have no liability for the consequences of use of such information.

**Short data sheet** — A short data sheet is an extract from a full data sheet with the same product type number(s) and title. A short data sheet is intended for quick reference only and should not be relied upon to contain detailed and full information. For detailed and full information see the relevant full data sheet, which is available on request via the local NXP Semiconductors sales office. In case of any inconsistency or conflict with the short data sheet, the full data sheet shall prevail.

### 15.3 Disclaimers

**General** — Information in this document is believed to be accurate and reliable. However, NXP Semiconductors does not give any representations or warranties, expressed or implied, as to the accuracy or completeness of such information and shall have no liability for the consequences of use of such information.

**Right to make changes** — NXP Semiconductors reserves the right to make changes to information published in this document, including without limitation specifications and product descriptions, at any time and without notice. This document supersedes and replaces all information supplied prior to the publication hereof.

**Suitability for use** — NXP Semiconductors products are not designed, authorized or warranted to be suitable for use in medical, military, aircraft, space or life support equipment, nor in applications where failure or malfunction of a NXP Semiconductors product can reasonably be expected to result in personal injury, death or severe property or environmental damage.

NXP Semiconductors accepts no liability for inclusion and/or use of NXP Semiconductors products in such equipment or applications and therefore such inclusion and/or use is at the customer's own risk.

**Applications** — Applications that are described herein for any of these products are for illustrative purposes only. NXP Semiconductors makes no representation or warranty that such applications will be suitable for the specified use without further testing or modification.

**Limiting values** — Stress above one or more limiting values (as defined in the Absolute Maximum Ratings System of IEC 60134) may cause permanent damage to the device. Limiting values are stress ratings only and operation of the device at these or any other conditions above those given in the Characteristics sections of this document is not implied. Exposure to limiting values for extended periods may affect device reliability.

**Terms and conditions of sale** — NXP Semiconductors products are sold subject to the general terms and conditions of commercial sale, as published at <http://www.nxp.com/profile/terms>, including those pertaining to warranty, intellectual property rights infringement and limitation of liability, unless explicitly otherwise agreed to in writing by NXP Semiconductors. In case of any inconsistency or conflict between information in this document and such terms and conditions, the latter will prevail.

**No offer to sell or license** — Nothing in this document may be interpreted or construed as an offer to sell products that is open for acceptance or the grant, conveyance or implication of any license under any copyrights, patents or other industrial or intellectual property rights.

### 15.4 Trademarks

Notice: All referenced brands, product names, service names and trademarks are the property of their respective owners.

**I<sup>2</sup>C-bus** — logo is a trademark of NXP B.V.

**SoftConnect** — is a trademark of NXP B.V.

**GoodLink** — is a trademark of NXP B.V.

## 16. Contact information

For additional information, please visit: <http://www.nxp.com>

For sales office addresses, send an email to: [salesaddresses@nxp.com](mailto:salesaddresses@nxp.com)

17. Contents

<b>1</b>	<b>General description</b> . . . . .	<b>1</b>	7.19	I <sup>2</sup> S-bus serial I/O controllers . . . . .	35
<b>2</b>	<b>Features</b> . . . . .	<b>1</b>	7.19.1	Features . . . . .	36
<b>3</b>	<b>Applications</b> . . . . .	<b>3</b>	7.20	General purpose 32-bit timers/external event counters . . . . .	36
<b>4</b>	<b>Ordering information</b> . . . . .	<b>3</b>	7.20.1	Features . . . . .	36
4.1	Ordering options . . . . .	3	7.21	Pulse width modulator . . . . .	37
<b>5</b>	<b>Block diagram</b> . . . . .	<b>4</b>	7.21.1	Features . . . . .	37
<b>6</b>	<b>Pinning information</b> . . . . .	<b>5</b>	7.22	Watchdog timer (WDT) . . . . .	38
6.1	Pinning . . . . .	5	7.22.1	Features . . . . .	38
6.2	Pin description . . . . .	8	7.23	RTC and battery RAM . . . . .	38
<b>7</b>	<b>Functional description</b> . . . . .	<b>23</b>	7.23.1	Features . . . . .	39
7.1	Architectural overview . . . . .	23	7.24	Clocking and power control . . . . .	39
7.2	On-chip SRAM . . . . .	24	7.24.1	Crystal oscillators . . . . .	39
7.3	Memory map . . . . .	25	7.24.1.1	Internal RC oscillator . . . . .	39
7.4	Interrupt controller . . . . .	26	7.24.1.2	Main oscillator . . . . .	39
7.4.1	Interrupt sources . . . . .	27	7.24.1.3	RTC oscillator . . . . .	40
7.5	Pin connect block . . . . .	27	7.24.2	PLL . . . . .	40
7.6	External memory controller . . . . .	27	7.24.3	Wake-up timer . . . . .	40
7.6.1	Features . . . . .	27	7.24.4	Power control . . . . .	40
7.7	General purpose DMA controller . . . . .	28	7.24.4.1	Idle mode . . . . .	41
7.7.1	Features . . . . .	28	7.24.4.2	Sleep mode . . . . .	41
7.8	Fast general purpose parallel I/O . . . . .	29	7.24.4.3	Power-down mode . . . . .	41
7.8.1	Features . . . . .	29	7.24.4.4	Power domains . . . . .	41
7.9	Ethernet . . . . .	30	7.25	System control . . . . .	42
7.9.1	Features . . . . .	30	7.25.1	Reset . . . . .	42
7.10	USB interface . . . . .	31	7.25.2	Bootling process . . . . .	42
7.10.1	USB device controller . . . . .	31	7.25.3	Brownout detection . . . . .	43
7.10.1.1	Features . . . . .	31	7.25.4	AHB bus . . . . .	43
7.10.2	USB Host Controller . . . . .	31	7.25.5	External interrupt inputs . . . . .	43
7.10.2.1	Features . . . . .	32	7.25.6	Memory mapping control . . . . .	43
7.10.3	USB OTG Controller . . . . .	32	7.26	Emulation and debugging . . . . .	43
7.10.3.1	Features . . . . .	32	7.26.1	EmbeddedICE . . . . .	44
7.11	CAN controller and acceptance filters . . . . .	32	7.26.2	Embedded trace . . . . .	44
7.11.1	Features . . . . .	32	7.26.3	RealMonitor . . . . .	44
7.12	10-bit ADC . . . . .	33	<b>8</b>	<b>Limiting values</b> . . . . .	<b>45</b>
7.12.1	Features . . . . .	33	<b>9</b>	<b>Static characteristics</b> . . . . .	<b>46</b>
7.13	10-bit DAC . . . . .	33	<b>10</b>	<b>Dynamic characteristics</b> . . . . .	<b>52</b>
7.13.1	Features . . . . .	33	10.1	Timing . . . . .	54
7.14	UARTs . . . . .	33	<b>11</b>	<b>Application information</b> . . . . .	<b>55</b>
7.14.1	Features . . . . .	33	11.1	Suggested USB interface solutions . . . . .	55
7.15	SPI serial I/O controller . . . . .	34	11.2	Suggested boot memory interface solutions . . . . .	59
7.15.1	Features . . . . .	34	<b>12</b>	<b>Package outline</b> . . . . .	<b>61</b>
7.16	SSP serial I/O controller . . . . .	34	<b>13</b>	<b>Abbreviations</b> . . . . .	<b>63</b>
7.16.1	Features . . . . .	34	<b>14</b>	<b>Revision history</b> . . . . .	<b>64</b>
7.17	SD/MMC card interface . . . . .	34	<b>15</b>	<b>Legal information</b> . . . . .	<b>65</b>
7.17.1	Features . . . . .	35	15.1	Data sheet status . . . . .	65
7.18	I <sup>2</sup> C-bus serial I/O controller . . . . .	35			
7.18.1	Features . . . . .	35			

continued >>

15.2 Definitions . . . . . 65  
15.3 Disclaimers . . . . . 65  
15.4 Trademarks . . . . . 65  
**16 Contact information . . . . . 65**  
**17 Contents . . . . . 66**

---

Please be aware that important notices concerning this document and the product(s) described herein, have been included in section 'Legal information'.

---



© NXP B.V. 2007.

All rights reserved.

For more information, please visit: <http://www.nxp.com>

For sales office addresses, please send an email to: [salesaddresses@nxp.com](mailto:salesaddresses@nxp.com)

Date of release: 5 October 2007

Document identifier: LPC2460\_0