

**2-CHANNEL HIGH DEFINITION AUDIO CODEC WITH****STAC9202****DESCRIPTION**

The STAC9202 is a high fidelity, 2-channel audio CODEC compliant with the High Definition Audio (HD Audio) specification defined by Intel. The STAC9202 implements direct interface to two digital microphones supporting advanced beam forming applications resulting in increased quality of applications requiring voice input.

**FEATURES**

- **High-integration HD Audio Product**
  - 2-channel PC Audio CODEC
  - Dual Digital Microphone interface
- **Two-Channel DACs and ADCs with 24-bit sample resolution**
  - High performance  $\Sigma\Delta$  technology
  - Sample rates up to 192 Hz
  - 100dB DAC SNR
- **Integrated Headphone Amps**
- **Stereo Analog Microphone**
  - Supports Stereo Microphone
  - Microphone Boost 0, 10, 20, 30, 40dB
- **Dual Digital Microphone Interface optimized for use with Akustica Digital Microphones**
- **S/PDIF In and Out**
- **Universal Jacks™ Functionality for jack retasking**
- **Adjustable VREF Out**
- **Digital PC Beep to all outputs**
- **+3.3 V, +4 V and +5 V analog power supply options**
- **48-pin LQFP Environmental Package**

**DESCRIPTION**

The STAC9202 is a high fidelity, 2-channel, audio CODEC compliant with the High Definition Audio (HD Audio) specification defined by Intel. The STAC9202 provides high quality, HD Audio capability to notebook and cost sensitive desktop PC applications.

The STAC9202 incorporates IDT's proprietary  $\Sigma\Delta$  technology to achieve a DAC SNR of 100 dB. The higher performance and quality of IDT's audio solutions brings consumer electronics level performance to the notebook, desktop and media center PC.

The STAC9202 provides stereo, 24-bit, full duplex resolution supporting sample rates up to 192 KHz by the DAC and ADC. The STAC9202 SPDIF In/Out support sample rates of 96 KHz, 48 KHz and 44.1 KHz plus SPDIF\_OUT supports 88.2 KHz. Additional sample rates are supported by the driver software.

The STAC9202 supports flexible configurations including switchable Headphone Out and Universal Jacks™ functionality for jack detection and re-tasking. The SPDIF interface provides connectivity to Consumer Electronic equipment like Dolby Digital decoders, powered speakers, mini disk drives or to a home entertainment system. All analog I/O pairs support LINE\_IN, LINE\_OUT and MIC.

## Table of Contents

|   |            |
|---|------------|
| <b>1. DESCRIPTION</b> .....                                 | <b>9</b>   |
| 1.1. Overview .....   | 9          |
| 1.2. Features .....   | 10         |
| <b>2. CHARACTERISTICS</b> .....                             | <b>11</b>  |
| 2.1. Audio Fidelity .....                                   | 11         |
| 2.2. Electrical Specifications .....                        | 11         |
| 2.3. STAC9202 5V Analog Performance Characteristics .....   | 13         |
| 2.4. STAC9202 4V Analog Performance Characteristics .....   | 14         |
| 2.5. STAC9202 3.3V Analog Performance Characteristics ..... | 14         |
| 2.6. Power Consumption .....                                | 15         |
| <b>3. DETAILED DESCRIPTION</b> .....                        | <b>16</b>  |
| 3.1. SPDIF Input .....                                      | 16         |
| 3.2. SPDIF Output .....                                     | 16         |
| 3.3. Digital Microphone Support .....                       | 16         |
| 3.4. Mono Out .....   | 16         |
| 3.5. Headphone Drivers Restrictions .....                   | 16         |
| 3.6. Universal Jacks .....                                  | 17         |
| <b>4. FUNCTIONAL BLOCK DIAGRAM</b> .....                    | <b>18</b>  |
| 4.1. STAC9202 .....   | 18         |
| <b>5. WIDGET DIAGRAM</b> .....                              | <b>19</b>  |
| 5.1. STAC9202 Widget Diagram .....                          | 19         |
| 5.2. STAC9202 Widget List .....                             | 20         |
| 5.3. Root Node (NID = 0x00) .....                           | 21         |
| 5.4. AFG Node (NID = 0x01) .....                            | 22         |
| 5.5. DAC0Cnvtr Node (NID = 0x02) .....                      | 37         |
| 5.6. ADC0Cnvtr Node (NID = 0x03) .....                      | 41         |
| 5.7. SPDIFinCnvtr Node (NID = 0x04) .....                   | 46         |
| 5.8. SPDIFoutCnvtr Node (NID = 0x05) .....                  | 52         |
| 5.9. DAC0Mux Node (NID = 0x06) .....                        | 57         |
| 5.10. DigInPin Node (NID = 0x07) .....                      | 60         |
| 5.11. DigOutPin Node (NID = 0x08) .....                     | 66         |
| 5.12. ADC0VolMux Node (NID = 0x09) .....                    | 71         |
| 5.13. MasterVol Node (NID = 0x0E) .....                     | 75         |
| 5.14. InPortMux Node (NID = 0x0F) .....                     | 78         |
| 5.15. PortAPin Node (NID = 0x0A) .....                      | 82         |
| 5.16. PortDPin Node (NID = 0x0D) .....                      | 88         |
| 5.17. PortCPin Node (NID = 0x0C) .....                      | 93         |
| 5.18. PortBPin Node (NID = 0x0B) .....                      | 99         |
| 5.19. MonoOutPin Node (NID = 0x10) .....                    | 105        |
| 5.20. CDPin Node (NID = 0x11) .....                         | 110        |
| 5.21. MonoOutMix Node (NID = 0x12) .....                    | 113        |
| 5.22. PCBeep Node (NID = 0x13) .....                        | 115        |
| 5.23. ADC0InMux Node (NID = 0x14) .....                     | 118        |
| 5.24. DigMicPin Node (NID = 0x15) .....                     | 123        |
| <b>6. ORDERING INFORMATION</b> .....                        | <b>127</b> |
| 6.1. STAC9202 Options and Part Numbers .....                | 127        |
| <b>7. PIN INFORMATION</b> .....                             | <b>128</b> |
| 7.1. STAC9202 Pin Diagram .....                             | 128        |
| 7.2. Pin Table for STAC9202 .....                           | 128        |
| <b>8. PACKAGE DRAWINGS</b> .....                            | <b>131</b> |
| 8.1. 48-Pin LQFP .....                                      | 131        |
| <b>9. SOLDER REFLOW PROFILE</b> .....                       | <b>132</b> |
| 9.1. Standard Reflow Profile Data .....                     | 132        |

|   |            |
|---|------------|
| 9.2. Pb Free Process - Package Classification Reflow Temperatures ..... | 133        |
| <b>10. REVISION HISTORY .....</b>                                       | <b>134</b> |

## List of Figures

|  |     |
|--|-----|
| Figure 1. STAC9202 Functional Block Diagram .....                  | 18  |
| Figure 2. STAC9202 Widget Diagram .....                            | 19  |
| Figure 3. STAC9202 Pin Diagram .....                               | 128 |
| Figure 4. 48-Pin LQFP Package Outline and Package Dimensions ..... | 131 |
| Figure 5. Solder Reflow Profile .....                              | 132 |

## List of Tables

|   |    |
|---|----|
| Table 1. Digital Power Consumption .....              | 15 |
| Table 2. 5 V Analog Power Consumption .....           | 15 |
| Table 3. High Definition Audio Widget .....           | 20 |
| Table 4. Root PnpID Command Verb Format .....         | 21 |
| Table 5. Root PnpID Command Response Format .....     | 21 |
| Table 6. Root RevID Command Verb Format .....         | 21 |
| Table 7. Root RevID Command Response Format .....     | 21 |
| Table 8. Root NodeInfo Command Verb Format .....      | 22 |
| Table 9. Root NodeInfo Command Response Format .....  | 22 |
| Table 10. AFG Reset Command Verb Format .....         | 22 |
| Table 11. AFG Reset Command Response Format .....     | 23 |
| Table 12. AFG NodeInfo Command Verb Format .....      | 23 |
| Table 13. AFG NodeInfo Command Response Format .....  | 23 |
| Table 14. AFG Type Command Verb Format .....          | 24 |
| Table 15. AFG Type Command Response Format .....      | 24 |
| Table 16. AFG GrpCap Command Verb Format .....        | 24 |
| Table 17. AFG GrpCap Command Response Format .....    | 24 |
| Table 18. AFG FrmtCap Command Verb Format .....       | 25 |
| Table 19. AFG FrmtCap Command Response Format .....   | 25 |
| Table 20. AFG StreamCap Command Verb Format .....     | 26 |
| Table 21. AFG StreamCap Command Response Format ..... | 26 |
| Table 22. AFG PwrCap Command Verb Format .....        | 26 |
| Table 23. AFG PwrCap Command Response Format .....    | 27 |
| Table 24. AFG GPIOCap Command Verb Format .....       | 27 |
| Table 25. AFG GPIOCap Command Response Format .....   | 28 |
| Table 26. AFG OutAmpCap Command Verb Format .....     | 28 |
| Table 27. AFG OutAmpCap Command Response Format ..... | 28 |
| Table 28. AFG PwrState Command Verb Format .....      | 29 |
| Table 29. AFG PwrState Command Response Format .....  | 29 |
| Table 30. AFG UnsolResp Command Verb Format .....     | 29 |
| Table 31. AFG UnsolResp Command Response Format ..... | 30 |
| Table 32. AFG GPIO Command Verb Format .....          | 30 |
| Table 33. AFG GPIO Command Response Format .....      | 30 |
| Table 34. AFG GPIOEn Command Verb Format .....        | 31 |
| Table 35. AFG GPIOEn Command Response Format .....    | 31 |
| Table 36. AFG GPIODir Command Verb Format .....       | 32 |
| Table 37. AFG GPIODir Command Response Format .....   | 32 |
| Table 38. AFG GPIOWake Command Verb Format .....      | 33 |
| Table 39. AFG GPIOWake Command Response Format .....  | 33 |

|   |    |
|---|----|
| Table 40. AFG GPIOUnsolEn Command Verb Format .....             | 33 |
| Table 41. AFG GPIOUnsolEn Command Response Format .....         | 34 |
| Table 42. AFG GPIOSticky Command Verb Format .....              | 34 |
| Table 43. AFG GPIOSticky Command Response Format .....          | 35 |
| Table 44. AFG SysID Command Verb Format .....                   | 35 |
| Table 45. AFG SysID Command Response Format .....               | 36 |
| Table 46. AFG DigMic Command Verb Format .....                  | 36 |
| Table 47. AFG DigMic Command Response Format .....              | 36 |
| Table 48. DAC0Cnvtr Frmt Command Verb Format .....              | 37 |
| Table 49. DAC0Cnvtr Frmt Command Response Format .....          | 37 |
| Table 50. DAC0Cnvtr WCap Command Verb Format .....              | 38 |
| Table 51. DAC0Cnvtr WCap Command Response Format .....          | 38 |
| Table 52. DAC0Cnvtr PwrState Command Verb Format .....          | 39 |
| Table 53. DAC0Cnvtr PwrState Command Response Format .....      | 39 |
| Table 54. DAC0Cnvtr Stream Command Verb Format .....            | 40 |
| Table 55. DAC0Cnvtr Stream Command Response Format .....        | 40 |
| Table 56. ADC0Cnvtr Frmt Command Verb Format .....              | 41 |
| Table 57. ADC0Cnvtr Frmt Command Response Format .....          | 41 |
| Table 58. ADC0Cnvtr WCap Command Verb Format .....              | 42 |
| Table 59. ADC0Cnvtr WCap Command Response Format .....          | 42 |
| Table 60. ADC0Cnvtr ConnLen Command Verb Format .....           | 43 |
| Table 61. ADC0Cnvtr ConnLen Command Response Format .....       | 43 |
| Table 62. ADC0Cnvtr ConnLst Command Verb Format .....           | 44 |
| Table 63. ADC0Cnvtr ConnLst Command Response Format .....       | 44 |
| Table 64. ADC0Cnvtr ProcState Command Verb Format .....         | 44 |
| Table 65. ADC0Cnvtr ProcState Command Response Format .....     | 44 |
| Table 66. ADC0Cnvtr PwrState Command Verb Format .....          | 45 |
| Table 67. ADC0Cnvtr PwrState Command Response Format .....      | 45 |
| Table 68. ADC0Cnvtr Stream Command Verb Format .....            | 45 |
| Table 69. ADC0Cnvtr Stream Command Response Format .....        | 45 |
| Table 70. SPDIFinCnvtr Frmt Command Verb Format .....           | 46 |
| Table 71. SPDIFinCnvtr Frmt Command Response Format .....       | 46 |
| Table 72. SPDIFinCnvtr WCap Command Verb Format .....           | 47 |
| Table 73. SPDIFinCnvtr WCap Command Response Format .....       | 47 |
| Table 74. SPDIFinCnvtr FrmtCap Command Verb Format .....        | 48 |
| Table 75. SPDIFinCnvtr FrmtCap Command Response Format .....    | 48 |
| Table 76. SPDIFinCnvtr StreamCap Command Verb Format .....      | 49 |
| Table 77. SPDIFinCnvtr StreamCap Command Response Format .....  | 50 |
| Table 78. SPDIFinCnvtr ConnLen Command Verb Format .....        | 50 |
| Table 79. SPDIFinCnvtr ConnLen Command Response Format .....    | 50 |
| Table 80. SPDIFinCnvtr ConnLst Command Verb Format .....        | 50 |
| Table 81. SPDIFinCnvtr ConnLst Command Response Format .....    | 51 |
| Table 82. SPDIFinCnvtr Stream Command Verb Format .....         | 51 |
| Table 83. SPDIFinCnvtr Stream Command Response Format .....     | 51 |
| Table 84. SPDIFinCnvtr DigCtl Command Verb Format .....         | 51 |
| Table 85. SPDIFinCnvtr DigCtl Command Response Format .....     | 52 |
| Table 86. SPDIFoutCnvtr Frmt Command Verb Format .....          | 52 |
| Table 87. SPDIFoutCnvtr Frmt Command Response Format .....      | 53 |
| Table 88. SPDIFoutCnvtr WCap Command Verb Format .....          | 54 |
| Table 89. SPDIFoutCnvtr WCap Command Response Format .....      | 54 |
| Table 90. SPDIFoutCnvtr FrmtCap Command Verb Format .....       | 55 |
| Table 91. SPDIFoutCnvtr FrmtCap Command Response Format .....   | 55 |
| Table 92. SPDIFoutCnvtr StreamCap Command Verb Format .....     | 56 |
| Table 93. SPDIFoutCnvtr StreamCap Command Response Format ..... | 56 |
| Table 94. SPDIFoutCnvtr Stream Command Verb Format .....        | 56 |

|   |    |
|---|----|
| Table 95. SPDIFoutCnvtr Stream Command Response Format .....  | 56 |
| Table 96. SPDIFoutCnvtr DigCtl Command Verb Format .....      | 57 |
| Table 97. SPDIFoutCnvtr DigCtl Command Response Format .....  | 57 |
| Table 98. DAC0Mux WCap Command Verb Format .....              | 57 |
| Table 99. DAC0Mux WCap Command Response Format .....          | 58 |
| Table 100. DAC0Mux ConnLen Command Verb Format .....          | 58 |
| Table 101. DAC0Mux ConnLen Command Response Format .....      | 59 |
| Table 102. DAC0Mux ConnSel Command Verb Format .....          | 59 |
| Table 103. DAC0Mux ConnSel Command Response Format .....      | 59 |
| Table 104. DAC0Mux ConnLst Command Verb Format .....          | 59 |
| Table 105. DAC0Mux ConnLst Command Response Format .....      | 59 |
| Table 106. DAC0Mux LR Command Verb Format .....               | 60 |
| Table 107. DAC0Mux LR Command Response Format .....           | 60 |
| Table 108. DigInPin WCap Command Verb Format .....            | 60 |
| Table 109. DigInPin WCap Command Response Format .....        | 61 |
| Table 110. DigInPin Cap Command Verb Format .....             | 61 |
| Table 111. DigInPin Cap Command Response Format .....         | 62 |
| Table 112. DigInPin PwrState Command Verb Format .....        | 62 |
| Table 113. DigInPin PwrState Command Response Format .....    | 62 |
| Table 114. DigInPin Ctl Command Verb Format .....             | 63 |
| Table 115. DigInPin Ctl Command Response Format .....         | 63 |
| Table 116. DigInPin UnsolResp Command Verb Format .....       | 63 |
| Table 117. DigInPin UnsolResp Command Response Format .....   | 64 |
| Table 118. DigInPin Sense Command Verb Format .....           | 64 |
| Table 119. DigInPin Sense Command Response Format .....       | 64 |
| Table 120. DigInPin EAPD Command Verb Format .....            | 65 |
| Table 121. DigInPin EAPD Command Response Format .....        | 65 |
| Table 122. DigInPin Config Command Verb Format .....          | 65 |
| Table 123. DigInPin Config Command Response Format .....      | 66 |
| Table 124. DigOutPin WCap Command Verb Format .....           | 66 |
| Table 125. DigOutPin WCap Command Response Format .....       | 66 |
| Table 126. DigOutPin Cap Command Verb Format .....            | 67 |
| Table 127. DigOutPin Cap Command Response Format .....        | 67 |
| Table 128. DigOutPin ConnLen Command Verb Format .....        | 68 |
| Table 129. DigOutPin ConnLen Command Response Format .....    | 68 |
| Table 130. DigOutPin ConnSel Command Verb Format .....        | 69 |
| Table 131. DigOutPin ConnSel Command Response Format .....    | 69 |
| Table 132. DigOutPin ConnLst Command Verb Format .....        | 69 |
| Table 133. DigOutPin ConnLst Command Response Format .....    | 69 |
| Table 134. DigOutPin Ctl Command Verb Format .....            | 70 |
| Table 135. DigOutPin Ctl Command Response Format .....        | 70 |
| Table 136. DigOutPin Config Command Verb Format .....         | 70 |
| Table 137. DigOutPin Config Command Response Format .....     | 70 |
| Table 138. ADC0VolMux VolRight Command Verb Format .....      | 71 |
| Table 139. ADC0VolMux VolRight Command Response Format .....  | 71 |
| Table 140. ADC0VolMux VolLeft Command Verb Format .....       | 72 |
| Table 141. ADC0VolMux VolLeft Command Response Format .....   | 72 |
| Table 142. ADC0VolMux WCap Command Verb Format .....          | 72 |
| Table 143. ADC0VolMux WCap Command Response Format .....      | 72 |
| Table 144. ADC0VolMux OutAmpCap Command Verb Format .....     | 73 |
| Table 145. ADC0VolMux OutAmpCap Command Response Format ..... | 73 |
| Table 146. ADC0VolMux ConnLen Command Verb Format .....       | 74 |
| Table 147. ADC0VolMux ConnLen Command Response Format .....   | 74 |
| Table 148. ADC0VolMux ConnLst Command Verb Format .....       | 74 |
| Table 149. ADC0VolMux ConnLst Command Response Format .....   | 74 |

|   |    |
|---|----|
| Table 150. MasterVol Right Command Verb Format .....        | 75 |
| Table 151. MasterVol Right Command Response Format .....    | 75 |
| Table 152. MasterVol Left Command Verb Format .....         | 75 |
| Table 153. MasterVol Left Command Response Format .....     | 75 |
| Table 154. MasterVol WCap Command Verb Format .....         | 76 |
| Table 155. MasterVol WCap Command Response Format .....     | 76 |
| Table 156. MasterVol ConnLen Command Verb Format .....      | 77 |
| Table 157. MasterVol ConnLen Command Response Format .....  | 77 |
| Table 158. MasterVol ConnLst Command Verb Format .....      | 77 |
| Table 159. MasterVol ConnLst Command Response Format .....  | 77 |
| Table 160. InPortMux VolRight Command Verb Format .....     | 78 |
| Table 161. InPortMux VolRight Command Response Format ..... | 78 |
| Table 162. InPortMux VolLeft Command Verb Format .....      | 78 |
| Table 163. InPortMux VolLeft Command Response Format .....  | 78 |
| Table 164. InPortMux WCap Command Verb Format .....         | 78 |
| Table 165. InPortMux WCap Command Response Format .....     | 79 |
| Table 166. InPortMux ConnLen Command Verb Format .....      | 79 |
| Table 167. InPortMux ConnLen Command Response Format .....  | 80 |
| Table 168. InPortMux AmpCap Command Verb Format .....       | 80 |
| Table 169. InPortMux AmpCap Command Response Format .....   | 80 |
| Table 170. InPortMux ConnSel Command Verb Format .....      | 81 |
| Table 171. InPortMux ConnSel Command Response Format .....  | 81 |
| Table 172. InPortMux ConnLst0 Command Verb Format .....     | 81 |
| Table 173. InPortMux ConnLst0 Command Response Format ..... | 81 |
| Table 174. InPortMux ConnLst4 Command Verb Format .....     | 81 |
| Table 175. InPortMux ConnLst4 Command Response Format ..... | 82 |
| Table 176. PortAPin WCap Command Verb Format .....          | 82 |
| Table 177. PortAPin WCap Command Response Format .....      | 82 |
| Table 178. PortAPin Cap Command Verb Format .....           | 83 |
| Table 179. PortAPin Cap Command Response Format .....       | 83 |
| Table 180. PortAPin ConnLen Command Verb Format .....       | 84 |
| Table 181. PortAPin ConnLen Command Response Format .....   | 84 |
| Table 182. PortAPin ConnLst Command Verb Format .....       | 84 |
| Table 183. PortAPin ConnLst Command Response Format .....   | 84 |
| Table 184. PortAPin Ctl Command Verb Format .....           | 85 |
| Table 185. PortAPin Ctl Command Response Format .....       | 85 |
| Table 186. PortAPin UnsolResp Command Verb Format .....     | 85 |
| Table 187. PortAPin UnsolResp Command Response Format ..... | 85 |
| Table 188. PortAPin Sense Command Verb Format .....         | 86 |
| Table 189. PortAPin Sense Command Response Format .....     | 86 |
| Table 190. PortAPin Config Command Verb Format .....        | 87 |
| Table 191. PortAPin Config Command Response Format .....    | 87 |
| Table 192. PortDPin WCap Command Verb Format .....          | 88 |
| Table 193. PortDPin WCap Command Response Format .....      | 88 |
| Table 194. PortDPin Cap Command Verb Format .....           | 89 |
| Table 195. PortDPin Cap Command Response Format .....       | 89 |
| Table 196. PortDPin ConnLen Command Verb Format .....       | 89 |
| Table 197. PortDPin ConnLen Command Response Format .....   | 90 |
| Table 198. PortDPin ConnLst Command Verb Format .....       | 90 |
| Table 199. PortDPin ConnLst Command Response Format .....   | 90 |
| Table 200. PortDPin Ctl Command Verb Format .....           | 90 |
| Table 201. PortDPin Ctl Command Response Format .....       | 91 |
| Table 202. PortDPin UnsolResp Command Verb Format .....     | 91 |
| Table 203. PortDPin UnsolResp Command Response Format ..... | 91 |
| Table 204. PortDPin Sense Command Verb Format .....         | 92 |

|   |     |
|---|-----|
| Table 205. PortDPin Sense Command Response Format .....     | 92  |
| Table 206. PortDPin Config Command Verb Format .....        | 92  |
| Table 207. PortDPin Config Command Response Format .....    | 93  |
| Table 208. PortCPin WCap Command Verb Format .....          | 93  |
| Table 209. PortCPin WCap Command Response Format .....      | 93  |
| Table 210. PortCPin Cap Command Verb Format .....           | 94  |
| Table 211. PortCPin Cap Command Response Format .....       | 94  |
| Table 212. PortCPin ConnLen Command Verb Format .....       | 95  |
| Table 213. PortCPin ConnLen Command Response Format .....   | 95  |
| Table 214. PortCPin ConnLst Command Verb Format .....       | 96  |
| Table 215. PortCPin ConnLst Command Response Format .....   | 96  |
| Table 216. PortCPin Ctl Command Verb Format .....           | 96  |
| Table 217. PortCPin Ctl Command Response Format .....       | 96  |
| Table 218. PortCPin UnsolResp Command Verb Format .....     | 97  |
| Table 219. PortCPin UnsolResp Command Response Format ..... | 97  |
| Table 220. PortCPin Sense Command Verb Format .....         | 98  |
| Table 221. PortCPin Sense Command Response Format .....     | 98  |
| Table 222. PortCPin Config Command Verb Format .....        | 98  |
| Table 223. PortCPin Config Command Response Format .....    | 99  |
| Table 224. PortBPin WCap Command Verb Format .....          | 99  |
| Table 225. PortBPin WCap Command Response Format .....      | 99  |
| Table 226. PortBPin Cap Command Verb Format .....           | 100 |
| Table 227. PortBPin Cap Command Response Format .....       | 100 |
| Table 228. PortBPin ConnLen Command Verb Format .....       | 101 |
| Table 229. PortBPin ConnLen Command Response Format .....   | 101 |
| Table 230. PortBPin ConnLst Command Verb Format .....       | 102 |
| Table 231. PortBPin ConnLst Command Response Format .....   | 102 |
| Table 232. PortBPin Ctl Command Verb Format .....           | 102 |
| Table 233. PortBPin Ctl Command Response Format .....       | 102 |
| Table 234. PortBPin UnsolResp Command Verb Format .....     | 103 |
| Table 235. PortBPin UnsolResp Command Response Format ..... | 103 |
| Table 236. PortBPin Sense Command Verb Format .....         | 104 |
| Table 237. PortBPin Sense Command Response Format .....     | 104 |
| Table 238. PortBPin Config Command Verb Format .....        | 104 |
| Table 239. PortBPin Config Command Response Format .....    | 105 |
| Table 240. MonoOutPin Vol Command Verb Format .....         | 105 |
| Table 241. MonoOutPin Vol Command Response Format .....     | 105 |
| Table 242. MonoOutPin WCap Command Verb Format .....        | 106 |
| Table 243. MonoOutPin WCap Command Response Format .....    | 106 |
| Table 244. MonoOutPin Cap Command Verb Format .....         | 107 |
| Table 245. MonoOutPin Cap Command Response Format .....     | 107 |
| Table 246. MonoOutPin ConnLen Command Verb Format .....     | 108 |
| Table 247. MonoOutPin ConnLen Command Response Format ..... | 108 |
| Table 248. MonoOutPin ConnLst Command Verb Format .....     | 108 |
| Table 249. MonoOutPin ConnLst Command Response Format ..... | 108 |
| Table 250. MonoOutPin Ctl Command Verb Format .....         | 109 |
| Table 251. MonoOutPin Ctl Command Response Format .....     | 109 |
| Table 252. MonoOutPin Config Command Verb Format .....      | 109 |
| Table 253. MonoOutPin Config Command Response Format .....  | 109 |
| Table 254. CDPin WCap Command Verb Format .....             | 110 |
| Table 255. CDPin WCap Command Response Format .....         | 110 |
| Table 256. CDPin Cap Command Verb Format .....              | 111 |
| Table 257. CDPin Cap Command Response Format .....          | 111 |
| Table 258. CDPin Ctl Command Verb Format .....              | 112 |
| Table 259. CDPin Ctl Command Response Format .....          | 112 |

|  |     |
|--|-----|
| Table 260. CDPin Config Command Verb Format .....            | 112 |
| Table 261. CDPin Config Command Response Format .....        | 113 |
| Table 262. MonoOutMix WCap Command Verb Format .....         | 113 |
| Table 263. MonoOutMix WCap Command Response Format .....     | 114 |
| Table 264. MonoOutMix ConnLen Command Verb Format .....      | 114 |
| Table 265. MonoOutMix ConnLen Command Response Format .....  | 115 |
| Table 266. MonoOutMix ConnLst Command Verb Format .....      | 115 |
| Table 267. MonoOutMix ConnLst Command Response Format .....  | 115 |
| Table 268. PCBeep Vol Command Verb Format .....              | 115 |
| Table 269. PCBeep Vol Command Response Format .....          | 116 |
| Table 270. PCBeep WCap Command Verb Format .....             | 116 |
| Table 271. PCBeep WCap Command Response Format .....         | 116 |
| Table 272. PCBeep OutAmpCap Command Verb Format .....        | 117 |
| Table 273. PCBeep OutAmpCap Command Response Format .....    | 117 |
| Table 274. PCBeep Gen Command Verb Format .....              | 117 |
| Table 275. PCBeep Gen Command Response Format .....          | 118 |
| Table 276. ADC0InMux WCap Command Verb Format .....          | 118 |
| Table 277. ADC0InMux WCap Command Response Format .....      | 118 |
| Table 278. ADC0InMux ConnLen Command Verb Format .....       | 119 |
| Table 279. ADC0InMux ConnLen Command Response Format .....   | 119 |
| Table 280. ADC0InMux ConnSel Command Verb Format .....       | 120 |
| Table 281. ADC0InMux ConnSel Command Response Format .....   | 120 |
| Table 282. ADC0InMux ConnLst Command Verb Format .....       | 120 |
| Table 283. ADC0InMux ConnLst Command Response Format .....   | 120 |
| Table 284. ADC0InMux LR Command Verb Format .....            | 121 |
| Table 285. ADC0InMux LR Command Response Format .....        | 121 |
| Table 286. ADC0InMux OutAmpCap Command Verb Format .....     | 121 |
| Table 287. ADC0InMux OutAmpCap Command Response Format ..... | 121 |
| Table 288. ADC0InMux VolRight Command Verb Format .....      | 122 |
| Table 289. ADC0InMux VolRight Command Response Format .....  | 122 |
| Table 290. ADC0InMux VolLeft Command Verb Format .....       | 122 |
| Table 291. ADC0InMux VolLeft Command Response Format .....   | 122 |
| Table 292. DigMicPin WCap Command Verb Format .....          | 123 |
| Table 293. DigMicPin WCap Command Response Format .....      | 123 |
| Table 294. DigMicPin Cap Command Verb Format .....           | 124 |
| Table 295. DigMicPin Cap Command Response Format .....       | 124 |
| Table 296. DigMicPin Ctl Command Verb Format .....           | 125 |
| Table 297. DigMicPin Ctl Command Response Format .....       | 125 |
| Table 298. DigMicPin Config Command Verb Format .....        | 125 |
| Table 299. DigMicPin Config Command Response Format .....    | 125 |



## 1. DESCRIPTION

### 1.1. Overview

The STAC9202 is a high fidelity, 2-channel, audio CODEC compliant with the High Definition Audio (HD Audio) specification defined by Intel. The STAC9202 provides high quality, HD Audio capability to notebook and cost sensitive desktop PC applications.

The STAC9202 incorporates IDT's proprietary  $\Sigma\Delta$  technology to achieve a DAC SNR of 100 dB. The higher performance and quality of IDT's audio solutions brings consumer electronics level performance to the notebook, desktop and media center PC.

The STAC9202 provides stereo, 24-bit, full duplex resolution supporting sample rates up to 192 KHz by the DAC and ADC. The STAC9202 SPDIF\_IN/SPDIF\_OUT support sample rates of 96 KHz, 48 KHz and 44.1 KHz plus SPDIF\_OUT supports 88.2 KHz. Additional sample rates are supported by the driver software.

The STAC9202 supports flexible configurations including switchable Headphone Out and Universal Jacks™ functionality for jack detection and re-tasking. The SPDIF interface provides connectivity to Consumer Electronic equipment like Dolby Digital decoders, powered speakers, mini disk drives or to a home entertainment system. All analog I/O pairs support LINE\_IN, LINE\_OUT and MIC.

MIC inputs can be programmed with 0/10/20/30/40dB boost. For more advanced configurations, the STAC9202 has four General Purpose I/O (GPIO) pins. The STAC9202 also provides a single ended CD input for compatibility with DRM solutions and to support legacy OS issues.

The STAC9202 integrates a headphone amplifier which is available on Ports A and D. The headphone amplifier is switchable between these two outputs for increased flexibility, enhanced user experience, and reduced implementation costs.

The Universal Jack capabilities allow the CODECs to detect when audio devices are connected to the CODEC, and allow the CODECs to be reconfigured to support these devices, regardless of which port they are plugged into. SPDIF input sensing is also supported. The fully parametric IDT SoftEQ can be initiated upon headphone jack insertion and removal for protection of notebook speakers.

*Note: The Jack Detect circuit and component selection are critical for accurate detection of audio jacks on individual ports. Please see the IDT STAC9202 reference design for circuit implementation details.*

The STAC9202 operates with a 3.3 V digital supply and a 3.3 V, 4 V and 5 V analog supply.

The STAC9202 is available in a 48-pin LQFP Environmental (ROHS) package.

The STAC9202 implements a direct interface to two digital microphones, supporting advanced beam forming applications resulting in increased quality of applications requiring voice input.

## 1.2. Features

- High-integration HD Audio Product
  - Two-channel PC Audio CODEC
  - Dual Digital Microphone interface
- Two-Channel DACs and ADCs with 24-bit sample resolution
  - High performance  $\Sigma\Delta$  technology
  - Sample rates up to 192 KHz
  - 100dB DAC SNR
- Integrated Headphone Amps
- Stereo Analog Microphone
  - Supports Stereo Mic
  - Microphone Boost 0, 10, 20, 30, 40dB
- Dual Digital Microphone Interface optimized for use with Akustica Digital Microphones
- S/PDIF In and Out
- Universal Jacks™ Functionality for jack retasking
- Adjustable VREF Out
- Digital PC Beep to all outputs
- +3.3 V, 4 V and +5 V analog power supply options
- 48-pin LQFP Environmental Package

## 2. CHARACTERISTICS

### 2.1. Audio Fidelity

|          |       |
|----------|-------|
| DAC SNR: | 100dB |
| ADC SNR: | 90dB  |

### 2.2. Electrical Specifications

#### 2.2.1. Absolute Maximum Ratings

Stresses above the ratings listed below can cause permanent damage to the STAC9202. These ratings, which are standard values for IDT commercially rated parts, are stress ratings only. Functional operation of the device at these or any other conditions above those indicated in the operational sections of the specifications is not implied. Exposure to absolute maximum rating conditions for extended periods can affect product reliability. Electrical parameters are guaranteed only over the recommended operating temperature range.

| Item                                  | Pin  | Maximum Rating  |
|---------------------------------------|------|---|
| Analog maximum supply voltage         | AVdd | 6 Volts   |
| Digital maximum supply voltage        | DVdd | 5.5 Volts   |
| VREFOUT output current                |      | 5 mA  |
| Voltage on any pin relative to ground |      | V <sub>ss</sub> - 0.3 V to V <sub>dd</sub> + 0.3 V  |
| Operating temperature                 |      | 0°C to +70°C  |
| Storage temperature                   |      | -55 °C to +125 °C   |
| Soldering temperature                 |      | 260 °C for 10 seconds *<br>Soldering temperature information for all available packages begins on page 132. |

#### 2.2.2. Recommended Operation Conditions

| Parameter   |                             | Min.  | Typ. | Max.  | Units |
|---|-----------------------------|-------|------|-------|-------|
| Power Supply Voltage  | Digital - 3.3 V             | 3.135 | 3.3  | 3.465 | V     |
|   | Analog - 3.3 V              | 3.135 | 3.3  | 3.465 | V     |
| (Note: The +4 V Analog voltage is supported by the +5 V version of the STAC9202.) | Analog - 4 V                | 3.8   | 4    | 4.2   | V     |
|   | Analog - 5 V                | 4.75  | 5    | 5.25  | V     |
| Ambient Operating Temperature   |                             | 0     |      | +70   | °C    |
| Case Temperature  | T <sub>case</sub> (48-LQFP) |       |      | +90   | °C    |

*ESD:* The STAC9202 is an ESD (electrostatic discharge) sensitive device. The human body and test equipment can accumulate and discharge electrostatic charges up to 4000 Volts without detection. Even though the STAC9202 implements internal ESD protection circuitry, proper ESD precautions should be followed to avoid damaging the functionality or performance.

### 2.3. STAC9202 5V Analog Performance Characteristics

( $T_{\text{ambient}} = 25\text{ }^{\circ}\text{C}$ ,  $AV_{\text{dd}} = 5.0\text{ V} \pm 5\%$ ,  $DV_{\text{dd}} = 3.3\text{ V} \pm 5\%$ ,  $AV_{\text{ss}} = DV_{\text{ss}} = 0\text{ V}$ ; 1 KHz input sine wave; Sample Frequency = 48 KHz; 0 dB = 1 VRMS, 10 K $\Omega$  / 50 pF load, Testbench Characterization BW: 20 Hz – 20 KHz, 0dB settings on all gain stages)

Min and Max performance targets are not included here. Specific system characteristics, such as layout, routing and external CODEC component selection influence the performance of the CODEC. To receive min/max levels for your system, please send us a unit and IDT will perform a full audio test suite and provide you with the results.

| Parameter   | Min    | Typ  | Max    | Unit |
|---|--------|------|--------|------|
| <b>Full Scale Input Voltage:</b>                            |        |      |        |      |
| All Analog Inputs with out boost                            | -      | 1.00 | -      | Vrms |
| All Analog Inputs with boost (Note 1)                       | -      | 0.03 | -      | Vrms |
| <b>Full Scale Output:</b>                                   |        |      |        |      |
| PCM (DAC) to All Analog Outputs                             | -      | 1.00 | -      | Vrms |
| HEADPHONE_OUT (32 $\Omega$ load) per channel                | -      | 50   | -      | mWpk |
| <b>Dynamic Range: -60dB signal level (Note 2)</b>           |        |      |        |      |
| PCM to All Analog Outputs                                   | -      | 99   | -      | dB   |
| All Analog Inputs to A/D (1 VRMS Input Referenced)          | -      | 88   | -      | dB   |
| Analog Frequency Response (Note 3)                          | 10     | -    | 30,000 | Hz   |
| <b>Total Harmonic Distortion + Noise (-3dB): (Note 4)</b>   |        |      |        |      |
| PCM to All Analog Outputs                                   | -      | -90  | -      | dB   |
| All Analog Inputs to A/D (-3dBV input Level)                | -      | -87  | -      | dB   |
| HEADPHONE_OUT (32 $\Omega$ load)                            | -      | -87  | -      | dB   |
| HEADPHONE_OUT (10 K $\Omega$ load)                          | -      | -90  | -      | dB   |
| <b>SNR (idle channel) (Note 5)</b>                          |        |      |        |      |
| DAC to All Analog Outputs                                   | -      | 100  | -      | dB   |
| All Analog Inputs to A/D with High Pass Filter enabled      | -      | 89   | -      | dB   |
| A/D & D/A Digital Filter Pass Band (Note 6)                 | 20     | -    | 19,200 | Hz   |
| A/D & D/A Digital Filter Transition Band                    | 19,200 | -    | 28,800 | Hz   |
| A/D & D/A Digital Filter Stop Band                          | 28,800 | -    | -      | Hz   |
| A/D & D/A Digital Filter Stop Band Rejcn (Note 7)           | -100   | -    | -      | dB   |
| DAC Out-of-Band Rejection (Note 8)                          | -55    | -    | -      | dB   |
| Group Delay (48 KHz sample rate)                            | -      | -    | 1      | ms   |
| Power Supply Rejection Ratio (1 KHz)                        | -      | -70  | -      | dB   |
| Power Supply Rejection Ratio (20 KHz)                       | -      | -40  | -      | dB   |
| Any Analog Input to ADC (10 KHz Signal Frequency) Crosstalk | -      | -90  | -      | dB   |
| Any Analog Input to ADC (1 KHz Signal Frequency) Crosstalk  | -      | -90  | -      | dB   |

| Parameter   | Min | Typ        | Max | Unit   |
|---|-----|------------|-----|--------|
| Spurious Tone Rejection                           | -   | -100       | -   | dB     |
| Attenuation, Gain Step Size ANALOG                | -   | 1.5        | -   | dB     |
| Attenuation, Gain Step Size DIGITAL               | -   | 0.75       | -   | dB     |
| Input Impedance                                   | -   | 50         | -   | KW     |
| Input Capacitance                                 | -   | 15         | -   | pF     |
| VREFout   | -   | 0.5 X AVdd | -   | V      |
| VREF  | -   | 0.45X AVdd | 0.5 | V      |
| Interchannel Gain Mismatch ADC                    | -   | -          | 0.5 | dB     |
| Interchannel Gain Mismatch DAC                    | -   | -          | -   | dB     |
| Gain Drift  | -   | 100        | -   | ppm/°C |
| DAC Offset Voltage                                | -   | 5          | 10  | mV     |
| Deviation from Linear Phase                       | -   | 10         | 1   | deg.   |
| All Analog Outputs Load Resistance                | -   | 10         | -   | KΩ     |
| All Analog Outputs Load Capacitance               | -   | -          | 50  | pF     |
| HEADPHONE_OUT Load Resistance                     | -   | 32         | -   | Ω      |
| HEADPHONE_OUT Load Capacitance                    | -   | 100        | -   | pF     |
| Mute Attenuation                                  | -   | -          | -   | dB     |
| PLL lock time                                     | -   | 96         | 200 | μsec   |
| PLL (or HD Audio Bit CLK) 24.576 MHz clock jitter | -   | 100        | 300 | psec   |

1. With +30 dB Boost on, 1.00 Vrms with Boost off.
2. Ratio of Full Scale signal to noise output with -60dB signal, measured "A weighted" over a 20 Hz to a 20 KHz bandwidth.
3. ± 1dB limits for Line Output & 0 dB gain, at -20dBV
4. Amplitude of THD+N, measured with A-weighting filter, over 20 Hz to 20 KHz bandwidth.
5. Ratio of Full Scale signal to idle channel noise output is measured "A weighted" over a 20 Hz to a 20 KHz bandwidth. (AES17-1991 Idle Channel Noise or EIAJ CP-307 Signal-to-noise Ratio).
6. Peak-to-Peak Ripple over Passband meets ± 0.25dB limits, 48 KHz Sample Frequency.
7. Stop Band rejection determines filter requirements. Out-of-Band rejection determines audible noise.
8. The integrated Out-of-Band noise generated by the DAC process, during normal PCM audio playback, over a bandwidth 28.8 to 100 KHz, with respect to a 1 Vrms DAC output.

#### 2.4. STAC9202 4V Analog Performance Characteristics

If you are interested in using the STAC9202 at 4V Analog, please contact IDT for more information.

#### 2.5. STAC9202 3.3V Analog Performance Characteristics

If you are interested in using the STAC9202 at 3.3V Analog, please contact IDT for more information.

## 2.6. Power Consumption

### 2.6.1. Digital

Table 1. Digital Power Consumption

| Power State | Typical | Max | units |
|-------------|---------|-----|-------|
| D0          | 20      | 25  | mA    |
| D1          | 14      | 17  | mA    |
| D2          | 14      | 17  | mA    |
| D3          | 14      | 17  | mA    |

### 2.6.2. 5V Analog

Table 2. 5 V Analog Power Consumption

| Power State | Typical | Max | units |
|-------------|---------|-----|-------|
| D0          | 30      | 36  | mA    |
| D1          | 12      | 26  | mA    |
| D2          | 12      | 26  | mA    |
| D3          | 11      | 26  | mA    |

### 3. DETAILED DESCRIPTION

#### 3.1. SPDIF Input

SPDIF\_IN can operate at 44.1 KHz, 48 KHz or 96 KHz and implements internal Jack Sensing. A sophisticated digital PLL allows automatic rate detection and accurate data recovery. The ability to accept consumer SPDIF voltage levels directly eliminates the need for costly external receiver ICs. Advanced features such as record slot select and SPDIF\_IN routing to the DAC allows for simultaneous record and play.

#### 3.2. SPDIF Output

SPDIF\_OUT can operate at 44.1 KHz, 48 KHz, 88.2 KHz and 96 KHz as defined in the Intel High Definition Audio Specification with resolutions up to 24 bits. This insures compatibility with all consumer audio gear and allows for convenient integration into home theater systems and media center PCs.

#### 3.3. Digital Microphone Support

The STAC9202 has a three-pin digital microphone interface that accepts high-rate, single-bit data streams from two digital microphones. Each microphone requires only one data line, and both microphones share a single clock line. This robust digital interface gives designers the flexibility to place the microphones in the optimum physical location on a system (such as along the top of the screen bezel) and use a simple, 3-wire ribbon cable to directly connect the microphones to the STAC9202 CODEC.

#### 3.4. Mono Out

The MONO Output is connected to pin 37 and has independent volume and mute control (see the Widget listing for details). The MONO Output derives its input from the output of the summing node that drives PORT A and PORT D. The following analog signals feed the summing amplifier that feeds the MONO Out summing amplifier:

- DAC Output: When enabled, both DAC Outputs are summed together.
- Analog PC BEEP: Source from Pin 12
- ADC Input: Stereo analog feed into the stereo ADC input.

The signals of the stereo channels from the DAC are combined into a single analog signal with a -6dB degradation in signal strength.

#### 3.5. Headphone Drivers Restrictions

It is not recommended that users operate both Port A and Port D as headphone drivers simultaneously. The operation of the two ports as headphone drivers degrades the signal quality of both outputs.<sup>1</sup>

*Note: 1) Headphone capabilities are on Port A (pins 39/41) and Port D (pins 35/36). Do NOT put headphone loads on both sets of pins at the same time.*



### 3.6. Universal Jacks

IDT's Universal Jacks technology allows for flexibility in board design and implementation.

On the STAC9202, only one function can be selected at a time. A set of pins cannot be set as input and output at the same time. However, the selected function can be changed at any time.

For the STAC9202 the Universal Jacks capabilities are as follows

- All of the STAC9202 ports support:
  - Line Out
  - Line In
  - Mic with 0/10/20/30/40<sup>2</sup> dB Mic Boost
- Ports A and D also support:
  - Headphone Out<sup>1</sup>

*Note: 1) Headphone capabilities are on Port A (pins 39/41) and Port D (pins 35/36). Do NOT put headphone loads on both sets of pins at the same time.*

*Note: 2) When the 40dB mic boost feature is enabled, additional gain increases greater than 6dB may result in significant audio quality degradation of the microphone audio input. In particular, when the 40dB MIC boost is active, the SNR, THD+N and DC offset will significantly degrade regardless of the input signal level.*

## 4. FUNCTIONAL BLOCK DIAGRAM

### 4.1. STAC9202

Figure 1. STAC9202 Functional Block Diagram

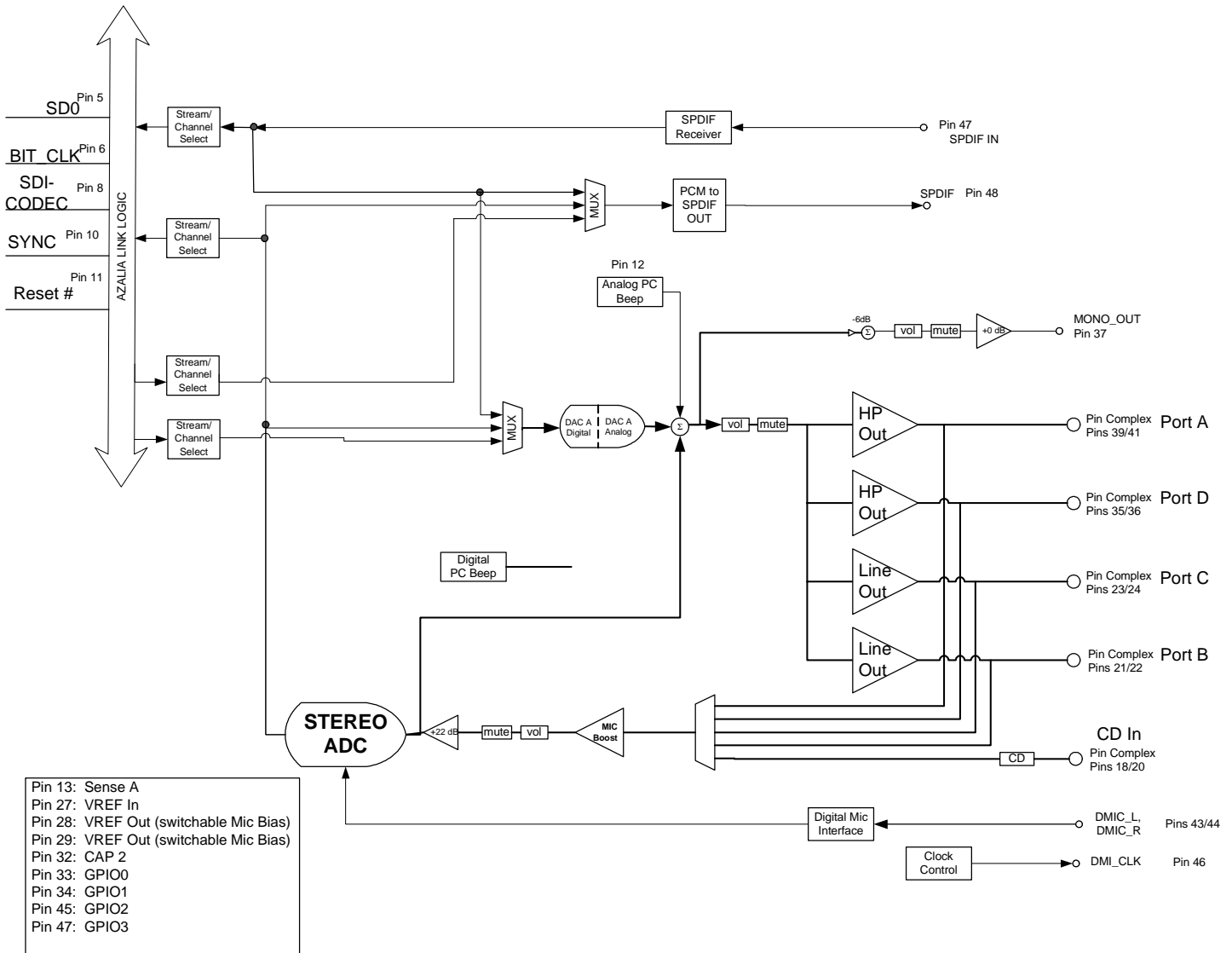

## 5. WIDGET DIAGRAM

### 5.1. STAC9202 Widget Diagram

Figure 2. STAC9202 Widget Diagram

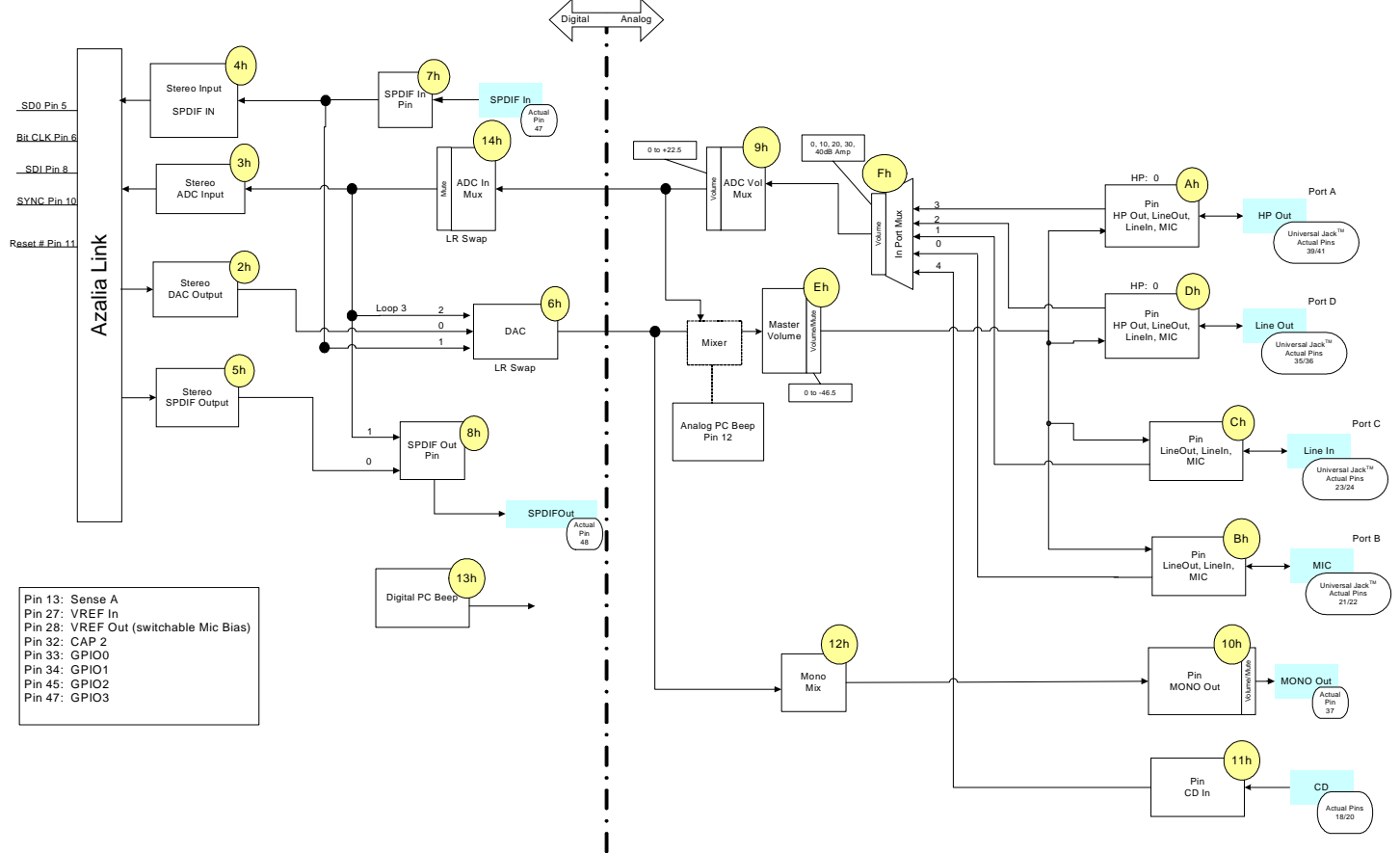

## 5.2. STAC9202 Widget List

Table 3. High Definition Audio Widget

| ID  | Widget Name          | Description  |
|-----|----------------------|--|
| 00h | Root                 | Root Node  |
| 01h | Audio Function Group | Audio Function Group   |
| 02h | DAC0                 | Stereo Output to DAC   |
| 03h | ADC0                 | Stereo Input from ADC  |
| 04h | SPDIF_IN             | Stereo Input for SPDIF_IN  |
| 05h | SPDIF_OUT            | Stereo Output for SPDIF_OUT  |
| 06h | DAC0Mux              | DAC Mux and Boost for outputs for DAC                                      |
| 07h | DigPin1              | Pin Widget for SPDIF_IN pin 47   |
| 08h | DigPin0              | Pin Widget for SPDIF_OUT pin 48  |
| 09h | ADC0VolMux           | ADC0 Volume  |
| 0Eh | MasterVolume         | Master Volume Controls   |
| 0Fh | InPortMux            | Port Mux for ADC0  |
| 0Ah | Port A               | Port A Pin Widget (Pins 39/41, configurable as HP, Line In, Line Out, Mic) |
| 0Dh | Port D               | Port D Pin Widget (Pins 35/36, configurable as HP, Line In, Line Out, Mic) |
| 0Ch | Port C               | Port C Pin Widget (Pins 23/24, configurable as Line Out, Mic)              |
| 0Bh | Port B               | Port B Pin Widget (Pins 21/22, configurable as Line Out, Mic)              |
| 10h | MonoOut              | Mono Output from DAC   |
| 11h | CD                   | CD Pin Widget pins 18/19/20  |
| 12h | MonoOutMix           | Mixer for Mono Output  |
| 13h | Digital PC Beep      | Digital PC Beep  |
| 14h | ADC0InMux            | Input Mux for ADC converter  |
| 15h | DigMicPin            | Pin Widget for Digital Microphone (Pins 43/44/46 configurable as a Mic)    |

### 5.3. Root Node (NID = 0x00)

#### 5.3.1. Root PnpID\_

Table 4. Root PnpID Command Verb Format

|     | Verb ID | Payload | Response           |
|-----|---------|---------|--------------------|
| Get | F00     | 00      | See bitfield table |

Table 5. Root PnpID Command Response Format

| Bit     | Bitfield Name | RW | Reset  | Description  |
|---------|---------------|----|--------|--|
| [31:16] | Vendor        | R  | 0x8384 | Vendor ID = 8384h  |
| [15:0]  | Device        | R  | 0x7630 | Device ID for:<br>STAC9202 = 7632<br>STAC9202 Dolby = 7633 |

#### 5.3.2. Root RevID

Table 6. Root RevID Command Verb Format

|     | Verb ID | Payload | Response           |
|-----|---------|---------|--------------------|
| Get | F00     | 02      | See bitfield table |

Table 7. Root RevID Command Response Format

| Bit     | Bitfield Name | RW | Reset | Description  |
|---------|---------------|----|-------|--|
| [31:24] | Rsvd          | R  | 0x00  | Reserved   |
| [23:20] | Major         | R  | 0x1   | Major rev number of compliant HD Audio specification |
| [19:16] | Minor         | R  | 0x0   | Minor rev number of compliant HD Audio specification |
| [15:8]  | Vendor        | R  | 0x01  | Vendor rev number for this device ID                 |
| [7:0]   | Stepping      | R  | 0x01  | Vendor stepping number within the given Vendor RevID |

### 5.3.3. Root NodeInfo

Table 8. Root NodeInfo Command Verb Format

|            | Verb ID | Payload | Response           |
|------------|---------|---------|--------------------|
| <b>Get</b> | F00     | 04      | See bitfield table |

Table 9. Root NodeInfo Command Response Format

| Bit     | Bitfield Name | RW | Reset | Description  |
|---------|---------------|----|-------|--|
| [31:24] | Rsvd2         | R  | 0x00  | Reserved   |
| [23:16] | StartNID      | R  | 0x01  | Starting node number (NID) of first function group |
| [15:8]  | Rsvd1         | R  | 0x00  | Reserved   |
| [7:0]   | TotalNodes    | R  | 0x01  | Total number of nodes                              |

## 5.4. AFG Node (NID = 0x01)

### 5.4.1. AFG Reset

Table 10. AFG Reset Command Verb Format

|             | Verb ID | Payload                          | Response           |
|-------------|---------|----------------------------------|--------------------|
| <b>Get</b>  | 7FF     | 00                               | See bitfield table |
| <b>Set1</b> | 7FF     | See bits [7:0] of bitfield table | 0000_0000h         |

Table 11. AFG Reset Command Response Format

| Bit    | Bitfield Name | RW | Reset | Description   |
|--------|---------------|----|-------|---|
| [31:0] | Response      | R  | 0x0   | Reserved. Overlaps Execute.   |
| [0]    | Execute       | W  | 0x0   | Function Reset. Function Group reset is executed when the Set verb 7FF is written with 8-bit payload of 00h. The CODEC should issue a response to acknowledge receipt of the verb, and then reset the affected Function Group and all associated widgets to their power-on reset values. Some controls such as Configuration Default controls should not be reset. Overlaps Response. |

#### 5.4.2. AFG NodeInfo

Table 12. AFG NodeInfo Command Verb Format

|     | Verb ID | Payload | Response           |
|-----|---------|---------|--------------------|
| Get | F00     | 04      | See bitfield table |

Table 13. AFG NodeInfo Command Response Format

| Bit     | Bitfield Name | RW | Reset | Description  |
|---------|---------------|----|-------|--|
| [31:24] | Rsvd2         | R  | 0x0   | Reserved   |
| [23:16] | StartNID      | R  | 0x02  | Starting node number for function group subordinate nodes. |
| [15:8]  | Rsvd1         | R  | 0x0   | Reserved   |
| [7:0]   | TotalNodes    | R  | 0x14  | Total number of nodes.<br>14h = STAC9202                   |

### 5.4.3. AFG Type

Table 14. AFG Type Command Verb Format

|     | Verb ID | Payload | Response           |
|-----|---------|---------|--------------------|
| Get | F00     | 05      | See bitfield table |

Table 15. AFG Type Command Response Format

| Bit    | Bitfield Name | RW | Reset | Description   |
|--------|---------------|----|-------|---|
| [31:9] | Rsvd          | R  | 0x0   | Reserved  |
| [8]    | Unsol         | R  | 0x1   | This node is capable of generating an unsolicited response, and will respond to the Unsolicited Response verb (Verb ID 708h). |
| [7:0]  | NodeType      | R  | 0x01  | Node type = Audio Function Group  |

### 5.4.4. AFG GrpCap

Table 16. AFG GrpCap Command Verb Format

|     | Verb ID | Payload | Response           |
|-----|---------|---------|--------------------|
| Get | F00     | 08      | See bitfield table |

Table 17. AFG GrpCap Command Response Format

| Bit     | Bitfield Name | RW | Reset | Description   |
|---------|---------------|----|-------|---|
| [31:17] | Rsvd3         | R  | 0x0   | Reserved  |
| [16]    | BeepGen       | R  | 0x1   | Optional Beep Generator is present  |
| [15:12] | Rsvd2         | R  | 0x0   | Reserved  |
| [11:8]  | InputDelay    | R  | 0xD   | Typical latency = 13 frames.<br>Number of samples between when the sample is received as an analog signal at the pin and when the digital representation is transmitted on the HD Audio link. |



Table 17. AFG GrpCap Command Response Format

| Bit   | Bitfield Name | RW | Reset | Description  |
|-------|---------------|----|-------|--|
| [7:4] | Rsvd1         | R  | 0x0   | Reserved   |
| [3:0] | OutputDelay   | R  | 0xD   | Typical latency = 13 frames.<br>Number of samples between when the signal is received from the HD Audio link and when it appears as an analog signal at the pin. |

#### 5.4.5. AFG FrmtCap

Table 18. AFG FrmtCap Command Verb Format

|     | Verb ID | Payload | Response           |
|-----|---------|---------|--------------------|
| Get | F00     | 0A      | See bitfield table |

Table 19. AFG FrmtCap Command Response Format

| Bit     | Bitfield Name | RW | Reset | Description                             |
|---------|---------------|----|-------|---|
| [31:21] | Rsvd2         | R  | 0x0   | Reserved                                |
| [20]    | B32           | R  | 0x0   | 32 bit audio formats are NOT supported  |
| [19]    | B24           | R  | 0x1   | 24 bit audio formats are supported      |
| [18]    | B20           | R  | 0x1   | 20 bit audio formats are supported      |
| [17]    | B16           | R  | 0x1   | 16 bit audio formats are supported      |
| [16]    | B8            | R  | 0x0   | 8 bit audio formats are NOT supported   |
| [15:12] | Rsvd1         | R  | 0x0   | Reserved                                |
| [11]    | R12           | R  | 0x0   | 384 KHz rate (8/1*48 KHz) NOT supported |
| [10]    | R11           | R  | 0x1   | 192.0 KHz rate (4/1*48 KHz) supported   |
| [9]     | R10           | R  | 0x1   | 176.4 KHz rate (4/1*44.1 KHz) supported |
| [8]     | R9            | R  | 0x1   | 96.0 KHz rate (2/1*48 KHz) supported    |
| [7]     | R8            | R  | 0x1   | 88.2 KHz rate (2/1*44.1 KHz) supported  |

Table 19. AFG FrmtCap Command Response Format

| Bit | Bitfield Name | RW | Reset | Description                                  |
|-----|---------------|----|-------|--|
| [6] | R7            | R  | 0x1   | 48.0 KHz rate supported (REQUIRED)           |
| [5] | R6            | R  | 0x1   | 44.1 KHz rate supported                      |
| [4] | R5            | R  | 0x0   | 32.0 KHz rate (2/3*48 KHz) NOT supported     |
| [3] | R4            | R  | 0x0   | 22.05 KHz rate (1/2*44.1 KHz) NOT supported  |
| [2] | R3            | R  | 0x0   | 16.0 KHz rate (1/3*48 KHz) NOT supported     |
| [1] | R2            | R  | 0x0   | 11.025 KHz rate (1/4*44.0 KHz) NOT supported |
| [0] | R1            | R  | 0x0   | 8.0 KHz rate (1/6*48 KHz) NOT supported      |

#### 5.4.6. AFG StreamCap

Table 20. AFG StreamCap Command Verb Format

|            | Verb ID | Payload | Response           |
|------------|---------|---------|--------------------|
| <b>Get</b> | F00     | 0B      | See bitfield table |

Table 21. AFG StreamCap Command Response Format

| Bit    | Bitfield Name | RW | Reset | Description  |
|--------|---------------|----|-------|--|
| [31:3] | Rsvd          | R  | 0x0   | Reserved   |
| [2]    | NonPCM        | R  | 0x0   | No support for non-PCM (AC3) data.                   |
| [1]    | Float32       | R  | 0x0   | No support for single-precision floating-point data. |
| [0]    | PCM           | R  | 0x1   | PCM-formatted data supported.                        |

#### 5.4.7. AFG PwrCap

Table 22. AFG PwrCap Command Verb Format

|            | Verb ID | Payload | Response           |
|------------|---------|---------|--------------------|
| <b>Get</b> | F00     | 0F      | See bitfield table |

Table 23. AFG PwrCap Command Response Format

| Bit    | Bitfield Name | RW | Reset | Description   |
|--------|---------------|----|-------|---|
| [31:4] | Rsvd          | R  | 0x0   | Reserved  |
| [3]    | D3            | R  | 0x1   | Power State D3 is supported. Allows for lowest possible power consuming state under software control (and still properly respond to a subsequent Power State command).                                    |
| [2]    | D2            | R  | 0x1   | Power State D2 is supported. Allows for lowest possible power consuming state from which it can return to fully on state within 10 ms.  |
| [1]    | D1            | R  | 0x1   | Power State D1 is supported. Allows for lowest possible power consuming state from which it can return to fully on state within 10 ms, excepting analog pass-through circuits which must remain fully on. |
| [0]    | D0            | R  | 0x1   | Power State D0 is supported. Node power state is fully on.  |

#### 5.4.8. AFG GPIOCap

Table 24. AFG GPIOCap Command Verb Format

|     | Verb ID | Payload | Response           |
|-----|---------|---------|--------------------|
| Get | F00     | 11      | See bitfield table |

Table 25. AFG GPIOCap Command Response Format

| Bit     | Bitfield Name | RW | Reset | Description   |
|---------|---------------|----|-------|---|
| [31]    | GPIWake       | R  | 0x1   | Wake capability. Assuming the Wake Enable Mask controls are enabled, GPIOs configured as inputs can cause a wake (generate a Status Change event on the link) when there is a change in level on the pin.           |
| [30]    | GPIUnsol      | R  | 0x1   | Unsolicited Response capability. Assuming the Unsolicited Enable Mask controls are enabled, GPIOs configured as inputs can generate an Unsolicited Response on the link when there is a change in level on the pin. |
| [29:24] | Rsvd          | R  | 0x0   | Reserved  |
| [23:16] | NumGPIs       | R  | 0x00  | Number of GPI pins supported  |
| [15:8]  | NumGPOs       | R  | 0x00  | Number of GPO pins supported  |
| [7:0]   | NumGPIOs      | R  | 0x04  | Number of GPIO pins supported   |

#### 5.4.9. AFG OutAmpCap

Table 26. AFG OutAmpCap Command Verb Format

|            | Verb ID | Payload | Response           |
|------------|---------|---------|--------------------|
| <b>Get</b> | F00     | 12      | See bitfield table |

Table 27. AFG OutAmpCap Command Response Format

| Bit     | Bitfield Name | RW | Reset | Description                                 |
|---------|---------------|----|-------|---|
| [31]    | Mute          | R  | 0x1   | Amplifier is capable of muting              |
| [30:23] | Rsvd3         | R  | 0x0   | Reserved                                    |
| [22:16] | StepSize      | R  | 0x05  | Size of each step in the gain range = 1.5dB |
| [15]    | Rsvd2         | R  | 0x0   | Reserved                                    |

Table 27. AFG OutAmpCap Command Response Format

| Bit    | Bitfield Name | RW | Reset | Description   |
|--------|---------------|----|-------|---|
| [14:8] | NumSteps      | R  | 0x1F  | Number of steps in the gain range = 31 (32 values, -46.5dB to +0dB) |
| [7]    | Rsvd1         | R  | 0x0   | Reserved  |
| [6:0]  | Offset        | R  | 0x1F  | 0dB-step is programmed with this offset                             |

#### 5.4.10. AFG PwrState

Table 28. AFG PwrState Command Verb Format

|             | Verb ID | Payload                          | Response           |
|-------------|---------|----------------------------------|--------------------|
| <b>Get</b>  | F05     | 00                               | See bitfield table |
| <b>Set1</b> | 705     | See bits [7:0] of bitfield table | 0000_0000h         |

Table 29. AFG PwrState Command Response Format

| Bit    | Bitfield Name | RW | Reset | Description  |
|--------|---------------|----|-------|--|
| [31:8] | Rsvd2         | R  | 0x0   | Reserved   |
| [7:4]  | Act           | R  | 0x2   | PS-Act: Actual power state of referenced node.   |
| [3:2]  | Rsvd1         | R  | 0x0   | Reserved   |
| [1:0]  | Set           | RW | 0x2   | PS-Set: Current power setting of referenced node.<br>0: All Powered-On<br>1: D1 => PR0, PR1<br>2: D2 => PR0, PR1, PR2, PR6, EAPD<br>3: D3 => PR6, PR5, PR3, PR2, PR1, PR0, EAPD<br>Note: PR4 is not mapped in HD Audio |

#### 5.4.11. AFG UnsolResp

Table 30. AFG UnsolResp Command Verb Format

|             | Verb ID | Payload                          | Response           |
|-------------|---------|----------------------------------|--------------------|
| <b>Get</b>  | F08     | 00                               | See bitfield table |
| <b>Set1</b> | 708     | See bits [7:0] of bitfield table | 0000_0000h         |

Table 31. AFG Unsolicited Command Response Format

| Bit    | Bitfield Name | RW | Reset | Description  |
|--------|---------------|----|-------|--|
| [31:8] | Rsvd2         | R  | 0x0   | Reserved   |
| [7]    | En            | RW | 0x0   | Allow generation of Unsolicited Responses.   |
| [6]    | Rsvd1         | R  | 0x0   | Reserved   |
| [5:0]  | Tag           | RW | 0x0   | Software programmable field returned in top six bits (31:26) of every Unsolicited Response generated by this node. |

#### 5.4.12. AFG GPIO

Table 32. AFG GPIO Command Verb Format

|             | Verb ID | Payload                          | Response           |
|-------------|---------|----------------------------------|--------------------|
| <b>Get</b>  | F15     | 00                               | See bitfield table |
| <b>Set1</b> | 715     | See bits [7:0] of bitfield table | 0000_0000h         |

Table 33. AFG GPIO Command Response Format

| Bit    | Bitfield Name | RW | Reset | Description  |
|--------|---------------|----|-------|--|
| [31:4] | Rsvd          | R  | 0x0   | Reserved   |
| [3]    | Data3         | RW | 0x0   | Data for GPIO3 (Pin 47/EAPD). If this GPIO bit is configured as Sticky (edge-sensitive) input, it can be cleared by writing zero (one) here when the corresponding Polarity Control bit is zero (one). |
| [2]    | Data2         | RW | 0x0   | Data for GPIO2 (Pin 45). If this GPIO bit is configured as Sticky (edge-sensitive) input, it can be cleared by writing zero (one) here when the corresponding Polarity Control bit is zero (one).      |

Table 33. AFG GPIO Command Response Format

| Bit | Bitfield Name | RW | Reset | Description   |
|-----|---------------|----|-------|---|
| [1] | Data1         | RW | 0x0   | Data for GPIO1 (Pin 34). If this GPIO bit is configured as Sticky (edge-sensitive) input, it can be cleared by writing zero (one) here when the corresponding Polarity Control bit is zero (one). |
| [0] | Data0         | RW | 0x0   | Data for GPIO0 (Pin 33). If this GPIO bit is configured as Sticky (edge-sensitive) input, it can be cleared by writing zero (one) here when the corresponding Polarity Control bit is zero (one). |

#### 5.4.13. AFG GPIOEn

Table 34. AFG GPIOEn Command Verb Format

|             | Verb ID | Payload                          | Response           |
|-------------|---------|----------------------------------|--------------------|
| <b>Get</b>  | F16     | 00                               | See bitfield table |
| <b>Set1</b> | 716     | See bits [7:0] of bitfield table | 0000_0000h         |

Table 35. AFG GPIOEn Command Response Format

| Bit    | Bitfield Name | RW | Reset | Description   |
|--------|---------------|----|-------|---|
| [31:4] | Rsvd          | R  | 0x0   | Reserved  |
| [3]    | Mask3         | RW | 0x0   | Enable for GPIO3:<br>0 = pin is disabled (Hi-Z state);<br>1 = pin is enabled; behavior determined by GPIO Direction control |
| [2]    | Mask2         | RW | 0x0   | Enable for GPIO2:<br>0 = pin is disabled (Hi-Z state);<br>1 = pin is enabled; behavior determined by GPIO Direction control |

Table 35. AFG GPIOEn Command Response Format

| Bit | Bitfield Name | RW | Reset | Description  |
|-----|---------------|----|-------|--|
| [1] | Mask1         | RW | 0x0   | Enable for GPIO1:<br>0 = pin is disabled (Hi-Z state);<br>1 = pin is enabled; behavior determined by<br>GPIO Direction control |
| [0] | Mask0         | RW | 0x0   | Enable for GPIO0:<br>0 = pin is disabled (Hi-Z state);<br>1 = pin is enabled; behavior determined by<br>GPIO Direction control |

#### 5.4.14. AFG GPIODir

Table 36. AFG GPIODir Command Verb Format

|             | Verb ID | Payload                          | Response           |
|-------------|---------|----------------------------------|--------------------|
| <b>Get</b>  | F17     | 00                               | See bitfield table |
| <b>Set1</b> | 717     | See bits [7:0] of bitfield table | 0000_0000h         |

Table 37. AFG GPIODir Command Response Format

| Bit    | Bitfield Name | RW | Reset | Description  |
|--------|---------------|----|-------|--|
| [31:4] | Rsvd          | R  | 0x0   | Reserved   |
| [3]    | Control3      | RW | 0x0   | Direction control for GPIO3<br>0 = GPIO signal is configured as input<br>1 = GPIO signal is configured as output |
| [2]    | Control2      | RW | 0x0   | Direction control for GPIO2<br>0 = GPIO signal is configured as input<br>1 = GPIO signal is configured as output |
| [1]    | Control1      | RW | 0x0   | Direction control for GPIO1<br>0 = GPIO signal is configured as input<br>1 = GPIO signal is configured as output |
| [0]    | Control0      | RW | 0x0   | Direction control for GPIO0<br>0 = GPIO signal is configured as input<br>1 = GPIO signal is configured as output |



## 5.4.15. AFG GPIOWake

Table 38. AFG GPIOWake Command Verb Format

|             | Verb ID | Payload                          | Response           |
|-------------|---------|----------------------------------|--------------------|
| <b>Get</b>  | F18     | 00                               | See bitfield table |
| <b>Set1</b> | 718     | See bits [7:0] of bitfield table | 0000_0000h         |

Table 39. AFG GPIOWake Command Response Format

| Bit    | Bitfield Name | RW | Reset | Description  |
|--------|---------------|----|-------|--|
| [31:4] | Rsvd          | R  | 0x0   | Reserved   |
| [3]    | En3           | RW | 0x0   | Wake enable for GPIO3:<br>0 = wake-up event is disabled;<br>1 = when HD Audio link is powered down (RST# is asserted), a wake-up event will trigger a Status Change Request event on the link. |
| [2]    | En2           | RW | 0x0   | Wake enable for GPIO2:<br>0 = wake-up event is disabled;<br>1 = when HD Audio link is powered down (RST# is asserted), a wake-up event will trigger a Status Change Request event on the link. |
| [1]    | En1           | RW | 0x0   | Wake enable for GPIO1:<br>0 = wake-up event is disabled;<br>1 = when HD Audio link is powered down (RST# is asserted), a wake-up event will trigger a Status Change Request event on the link. |
| [0]    | En0           | RW | 0x0   | Wake enable for GPIO0:<br>0 = wake-up event is disabled;<br>1 = when HD Audio link is powered down (RST# is asserted), a wake-up event will trigger a Status Change Request event on the link. |

## 5.4.16. AFG GPIOUnsolEn

Table 40. AFG GPIOUnsolEn Command Verb Format

|             | Verb ID | Payload                          | Response           |
|-------------|---------|----------------------------------|--------------------|
| <b>Get</b>  | F19     | 00                               | See bitfield table |
| <b>Set1</b> | 719     | See bits [7:0] of bitfield table | 0000_0000h         |

Table 41. AFG GPIOUnsolEn Command Response Format

| Bit    | Bitfield Name | RW | Reset | Description   |
|--------|---------------|----|-------|---|
| [31:4] | Rsvd          | R  | 0x0   | Reserved  |
| [3]    | Mask3         | RW | 0x0   | Unsolicited enable mask for GPIO3. If set, and the Unsolicited Response control for this widget has been enabled, an unsolicited response will be sent when GPIO3 is configured as input and changes state. |
| [2]    | Mask2         | RW | 0x0   | Unsolicited enable mask for GPIO2. If set, and the Unsolicited Response control for this widget has been enabled, an unsolicited response will be sent when GPIO2 is configured as input and changes state. |
| [1]    | Mask1         | RW | 0x0   | Unsolicited enable mask for GPIO1. If set, and the Unsolicited Response control for this widget has been enabled, an unsolicited response will be sent when GPIO1 is configured as input and changes state. |
| [0]    | Mask0         | RW | 0x0   | Unsolicited enable mask for GPIO0. If set, and the Unsolicited Response control for this widget has been enabled, an unsolicited response will be sent when GPIO0 is configured as input and changes state. |

#### 5.4.17. AFG GPIOSticky

Table 42. AFG GPIOSticky Command Verb Format

|             | Verb ID | Payload                          | Response           |
|-------------|---------|----------------------------------|--------------------|
| <b>Get</b>  | F1A     | 00                               | See bitfield table |
| <b>Set1</b> | 71A     | See bits [7:0] of bitfield table | 0000_0000h         |

Table 43. AFG GPIOSticky Command Response Format

| Bit    | Bitfield Name | RW | Reset | Description   |
|--------|---------------|----|-------|---|
| [31:4] | Rsvd          | R  | 0x0   | Reserved  |
| [3]    | Mask3         | RW | 0x0   | GPIO3 input type (when configured as input):<br>0 = Non-Sticky (level-sensitive)<br>1 = Sticky (edge-sensitive)<br>Sticky inputs are cleared by writing zero to corresponding bit of GPIO Data register. GPIO Polarity determines rising or falling edge sensitivity. |
| [2]    | Mask2         | RW | 0x0   | GPIO2 input type (when configured as input):<br>0 = Non-Sticky (level-sensitive)<br>1 = Sticky (edge-sensitive)<br>Sticky inputs are cleared by writing zero to corresponding bit of GPIO Data register. GPIO Polarity determines rising or falling edge sensitivity. |
| [1]    | Mask1         | RW | 0x0   | GPIO1 input type (when configured as input):<br>0 = Non-Sticky (level-sensitive)<br>1 = Sticky (edge-sensitive)<br>Sticky inputs are cleared by writing zero to corresponding bit of GPIO Data register. GPIO Polarity determines rising or falling edge sensitivity. |
| [0]    | Mask0         | RW | 0x0   | GPIO0 input type (when configured as input):<br>0 = Non-Sticky (level-sensitive)<br>1 = Sticky (edge-sensitive)<br>Sticky inputs are cleared by writing zero to corresponding bit of GPIO Data register. GPIO Polarity determines rising or falling edge sensitivity. |

#### 5.4.18. AFG SysID

Table 44. AFG SysID Command Verb Format

|             | Verb ID | Payload                            | Response           |
|-------------|---------|------------------------------------|--------------------|
| <b>Get</b>  | F20     | 00                                 | See bitfield table |
| <b>Set1</b> | 720     | See bits [7:0] of bitfield table   | 0000_0000h         |
| <b>Set2</b> | 721     | See bits [15:8] of bitfield table  | 0000_0000h         |
| <b>Set3</b> | 722     | See bits [23:16] of bitfield table | 0000_0000h         |
| <b>Set4</b> | 723     | See bits [31:24] of bitfield table | 0000_0000h         |

Table 45. AFG SysID Command Response Format

| Bit     | Bitfield Name | RW | Reset | Description                                       |
|---------|---------------|----|-------|---|
| [31:24] | Subsystem3    | RW | 0x00  | Subsystem ID. (Any non-zero value)                |
| [23:16] | Subsystem2    | RW | 0x00  | Subsystem ID. (Any non-zero value)                |
| [15:8]  | Subsystem1    | RW | 0x01  | Subsystem ID. (Any non-zero value)                |
| [7:0]   | Assembly      | RW | 0x00  | Assembly ID.<br>(Not applicable to CODEC vendors) |

#### 5.4.19. AFG DigMic

Table 46. AFG DigMic Command Verb Format

|             | Verb ID | Payload                          | Response           |
|-------------|---------|----------------------------------|--------------------|
| <b>Get</b>  | FEA     | 00                               | See bitfield table |
| <b>Set1</b> | 7EA     | See bits [7:0] of bitfield table | 0000_0000h         |

Table 47. AFG DigMic Command Response Format

| Bit    | Bitfield Name | RW | Reset | Description  |
|--------|---------------|----|-------|--|
| [31:8] | Rsvd          | R  | 0x0   | Reserved   |
| [7:6]  | PhAdj         | RW | 0x0   | Selects what phase of the DigMic clock the data should be latched:<br>0 = rising edge<br>1 = center of high<br>2 = falling edge<br>3 = center of low |
| [5:4]  | Rate          | RW | 0x2   | Selects the DigMic rate:<br>0 = 4 MHz<br>1 = 3 MHz<br>2 = 2 MHz<br>3 = 1 MHz   |

Table 47. AFG DigMic Command Response Format

| Bit   | Bitfield Name | RW | Reset | Description   |
|-------|---------------|----|-------|---|
| [3:2] | Rsvd2         | R  | 0x0   | Reserved  |
| [1:0] | Mode          | RW | 0x1   | Selects the DigMic mode:<br>0 = disabled<br>1 = dual mono<br>2 = single stereo 0<br>3 = single stereo 1 |

## 5.5. DAC0Cnvtr Node (NID = 0x02)

### 5.5.1. DAC0Cnvtr Frmt

Table 48. DAC0Cnvtr Frmt Command Verb Format

|             | Verb ID | Payload                           | Response           |
|-------------|---------|-----------------------------------|--------------------|
| <b>Get</b>  | A       | 0000                              | See bitfield table |
| <b>Set1</b> | 2       | See bits [15:0] of bitfield table | 0000_0000h         |

Table 49. DAC0Cnvtr Frmt Command Response Format

| Bit     | Bitfield Name | RW | Reset | Description   |
|---------|---------------|----|-------|---|
| [31:16] | Rsvd2         | R  | 0x0   | Reserved  |
| [15]    | StrmType      | R  | 0x0   | Stream Type: only PCM streams are supported by this widget.   |
| [14]    | RateBase      | RW | 0x0   | Sample Base Rate<br>0 = 48 KHz<br>1 = 44.1 KHz  |
| [13:11] | RateMult      | RW | 0x0   | Sample Base Rate Multiple<br>000 = 48 KHz / 44.1 KHz or less<br>001 = x2<br>010 = Reserved (x3)<br>011 = x4<br>100-111 = Reserved |

Table 49. DAC0Cnvtr Frmt Command Response Format

| Bit    | Bitfield Name | RW | Reset | Description  |
|--------|---------------|----|-------|--|
| [10:8] | RateDiv       | RW | 0x0   | Sample Base Rate Divisor<br>000 = Divide by 1<br>001 = Divide by 2<br>010 = Divide by 3<br>011 = Divide by 4<br>100 = Divide by 5<br>101 = Divide by 6<br>110 = Divide by 7<br>111 = Divide by 8 |
| [7]    | Rsvd1         | R  | 0x0   | Reserved   |
| [6:4]  | NumBits       | RW | 0x3   | Bits per Sample:<br>000 = 8 bits<br>001 = 16 bits<br>010 = 20 bits<br>011 = 24 bits<br>100-111 = Reserved  |
| [3:0]  | NumChan       | RW | 0x1   | Number of Channels in each frame of the stream.<br>0000 = 1 channel<br>0001 = 2 channels<br>...<br>1111 = 16 channels  |

### 5.5.2. DAC0Cnvtr WCap

Table 50. DAC0Cnvtr WCap Command Verb Format

|            | Verb ID | Payload | Response           |
|------------|---------|---------|--------------------|
| <b>Get</b> | F00     | 09      | See bitfield table |

Table 51. DAC0Cnvtr WCap Command Response Format

| Bit     | Bitfield Name | RW | Reset | Description                            |
|---------|---------------|----|-------|--|
| [31:24] | Rsvd2         | R  | 0x0   | Reserved                               |
| [23:20] | Type          | R  | 0x0   | Widget type = Audio Output             |
| [19:16] | Delay         | R  | 0xD   | Number of sample delays through widget |
| [15:12] | Rsvd1         | R  | 0x0   | Reserved                               |

Table 51. DAC0Cnvtr WCap Command Response Format

| Bit  | Bitfield Name | RW | Reset | Description  |
|------|---------------|----|-------|--|
| [11] | SwapCap       | R  | 0x0   | No left/right channel swap capability  |
| [10] | PwrCntrl      | R  | 0x1   | Power State control is supported   |
| [9]  | DigitalStrm   | R  | 0x0   | Widget supports an Analog stream   |
| [8]  | ConnList      | R  | 0x0   | No connection list is present  |
| [7]  | UnsolCap      | R  | 0x0   | No support for Unsolicited Response  |
| [6]  | ProcWidget    | R  | 0x0   | No Processing Controls parameter   |
| [5]  | Stripe        | R  | 0x0   | No support for striping  |
| [4]  | FormatOvrd    | R  | 0x0   | No format info; use default format parameters from Audio Function node instead       |
| [3]  | AmpParamOvrd  | R  | 0x0   | No amplifier info; use default amplifier parameters from Audio Function node instead |
| [2]  | OutAmpPrsnt   | R  | 0x0   | No output amp  |
| [1]  | InAmpPrsnt    | R  | 0x0   | No input amp   |
| [0]  | Stereo        | R  | 0x1   | Stereo widget  |

### 5.5.3. DAC0Cnvtr PwrState

Table 52. DAC0Cnvtr PwrState Command Verb Format

|             | Verb ID | Payload                          | Response           |
|-------------|---------|----------------------------------|--------------------|
| <b>Get</b>  | F05     | 00                               | See bitfield table |
| <b>Set1</b> | 705     | See bits [7:0] of bitfield table | 0000_0000h         |

Table 53. DAC0Cnvtr PwrState Command Response Format

| Bit    | Bitfield Name | RW | Reset | Description                                    |
|--------|---------------|----|-------|--|
| [31:8] | Rsvd2         | R  | 0x0   | Reserved                                       |
| [7:4]  | Act           | R  | 0x3   | PS-Act: Actual power state of referenced node. |

Table 53. DAC0Cnvtr PwrState Command Response Format

| Bit   | Bitfield Name | RW | Reset | Description   |
|-------|---------------|----|-------|---|
| [3:2] | Rsvd1         | R  | 0x0   | Reserved  |
| [1:0] | Set           | RW | 0x3   | PS-Set: Current power setting of referenced node.<br>00 - Fully on.<br>01 - Fully on.<br>10 - Fully on.<br>11 - Powered down. |

#### 5.5.4. DAC0Cnvtr Stream

Table 54. DAC0Cnvtr Stream Command Verb Format

|             | Verb ID | Payload                          | Response           |
|-------------|---------|----------------------------------|--------------------|
| <b>Get</b>  | F06     | 00                               | See bitfield table |
| <b>Set1</b> | 706     | See bits [7:0] of bitfield table | 0000_0000h         |

Table 55. DAC0Cnvtr Stream Command Response Format

| Bit    | Bitfield Name | RW | Reset | Description   |
|--------|---------------|----|-------|---|
| [31:8] | Rsvd          | R  | 0x0   | Reserved  |
| [7:4]  | ID            | RW | 0x0   | Software-programmable integer representing link stream ID used by the converter widget. By convention stream 0 is reserved as unused. |
| [3:0]  | Ch            | RW | 0x0   | Integer representing lowest channel used by converter.  |



## 5.6. ADC0Cnvtr Node (NID = 0x03)

### 5.6.1. ADC0Cnvtr Frmt

Table 56. ADC0Cnvtr Frmt Command Verb Format

|             | Verb ID | Payload                           | Response           |
|-------------|---------|-----------------------------------|--------------------|
| <b>Get</b>  | A       | 0000                              | See bitfield table |
| <b>Set1</b> | 2       | See bits [15:0] of bitfield table | 0000_0000h         |

Table 57. ADC0Cnvtr Frmt Command Response Format

| Bit     | Bitfield Name | RW | Reset | Description  |
|---------|---------------|----|-------|--|
| [31:16] | Rsvd2         | R  | 0x0   | Reserved   |
| [15]    | StrmType      | RW | 0x0   | Stream Type<br>0 = PCM<br>1 = Non-PCM (remaining bits in this verb have other meanings)  |
| [14]    | RateBase      | RW | 0x0   | Sample Base Rate<br>0 = 48 KHz<br>1 = 44.1 KHz   |
| [13:11] | RateMult      | RW | 0x0   | Sample Base Rate Multiple<br>000 = 48 KHz / 44.1 KHz or less<br>001 = x2<br>010 = Reserved (x3)<br>011 = x4<br>100-111 = Reserved  |
| [10:8]  | RateDiv       | RW | 0x0   | Sample Base Rate Divisor<br>000 = Divide by 1<br>001 = Divide by 2<br>010 = Divide by 3<br>011 = Divide by 4<br>100 = Divide by 5<br>101 = Divide by 6<br>110 = Divide by 7<br>111 = Divide by 8 |
| [7]     | Rsvd1         | R  | 0x0   | Reserved   |

Table 57. ADC0Cnvtr Frmt Command Response Format

| Bit   | Bitfield Name | RW | Reset | Description   |
|-------|---------------|----|-------|---|
| [6:4] | NumBits       | RW | 0x3   | Bits per Sample<br>000 = 8 bits<br>001 = 16 bits<br>010 = 20 bits<br>011 = 24 bits<br>100-111 = Reserved              |
| [3:0] | NumChan       | RW | 0x1   | Number of Channels in each frame of the stream.<br>0000 = 1 channel<br>0001 = 2 channels<br>...<br>1111 = 16 channels |

### 5.6.2. ADC0Cnvtr WCap

Table 58. ADC0Cnvtr WCap Command Verb Format

|     | Verb ID | Payload | Response           |
|-----|---------|---------|--------------------|
| Get | F00     | 09      | See bitfield table |

Table 59. ADC0Cnvtr WCap Command Response Format

| Bit     | Bitfield Name | RW | Reset | Description                            |
|---------|---------------|----|-------|--|
| [31:24] | Rsvd2         | R  | 0x0   | Reserved                               |
| [23:20] | Type          | R  | 0x1   | Widget type = Audio Input              |
| [19:16] | Delay         | R  | 0xD   | Number of sample delays through widget |
| [15:12] | Rsvd1         | R  | 0x0   | Reserved                               |
| [11]    | SwapCap       | R  | 0x0   | No left/right channel swap capability  |
| [10]    | PwrCntrl      | R  | 0x1   | Power State control is supported       |
| [9]     | DigitalStrm   | R  | 0x0   | Widget supports an Analog stream       |
| [8]     | ConnList      | R  | 0x1   | Connection list is present             |
| [7]     | UnsolCap      | R  | 0x0   | No support for Unsolicited Response    |

Table 59. ADC0Cnvtr WCap Command Response Format

| Bit | Bitfield Name | RW | Reset | Description  |
|-----|---------------|----|-------|--|
| [6] | ProcWidget    | R  | 0x1   | Software should query the Processing Controls parameter for this widget.             |
| [5] | Stripe        | R  | 0x0   | No support for striping  |
| [4] | FormatOvrd    | R  | 0x0   | No format info; use default format parameters from Audio Function node instead       |
| [3] | AmpParamOvrd  | R  | 0x0   | No amplifier info; use default amplifier parameters from Audio Function node instead |
| [2] | OutAmpPrsnt   | R  | 0x0   | No output amp  |
| [1] | InAmpPrsnt    | R  | 0x0   | No input amp   |
| [0] | Stereo        | R  | 0x1   | Stereo widget  |

### 5.6.3. ADC0Cnvtr ConnLen

Table 60. ADC0Cnvtr ConnLen Command Verb Format

|            | Verb ID | Payload | Response           |
|------------|---------|---------|--------------------|
| <b>Get</b> | F00     | 0E      | See bitfield table |

Table 61. ADC0Cnvtr ConnLen Command Response Format

| Bit    | Bitfield Name | RW | Reset | Description  |
|--------|---------------|----|-------|--|
| [31:8] | Rsvd          | R  | 0x0   | Reserved.  |
| [7]    | LongForm      | R  | 0x0   | Connection list uses short-form (7-bit) NID entries. |
| [6:0]  | N             | R  | 0x01  | Number of NID entries in connection list.            |

5.6.4. *ADC0Cnvtr ConnLst*

Table 62. ADC0Cnvtr ConnLst Command Verb Format

|            | Verb ID | Payload | Response           |
|------------|---------|---------|--------------------|
| <b>Get</b> | F02     | 00      | See bitfield table |

Table 63. ADC0Cnvtr ConnLst Command Response Format

| Bit     | Bitfield Name | RW | Reset | Description        |
|---------|---------------|----|-------|--------------------|
| [31:24] | Entry3        | R  | 0x00  | Unused list entry. |
| [23:16] | Entry2        | R  | 0x00  | Unused list entry. |
| [15:8]  | Entry1        | R  | 0x00  | Unused list entry. |
| [7:0]   | Entry0        | R  | 0x14  | ADC0InMux          |

5.6.5. *ADC0Cnvtr ProcState*

Table 64. ADC0Cnvtr ProcState Command Verb Format

|             | Verb ID | Payload                          | Response           |
|-------------|---------|----------------------------------|--------------------|
| <b>Get</b>  | F03     | 00                               | See bitfield table |
| <b>Set1</b> | 703     | See bits [7:0] of bitfield table | 0000_0000h         |

Table 65. ADC0Cnvtr ProcState Command Response Format

| Bit    | Bitfield Name | RW | Reset | Description   |
|--------|---------------|----|-------|---|
| [31:8] | Rsvd2         | R  | 0x0   | Reserved  |
| [7]    | HPFOffsetDis  | RW | 0x0   | High Pass Filter Offset Calculation Disable<br>0 = Calculation enabled.<br>1 = Calculation disabled.  |
| [6:2]  | Rsvd1         | R  | 0x0   | Reserved  |
| [1:0]  | HPFByp        | RW | 0x1   | Processing State = 00 (OFF): bypass the ADC high pass filter;<br>Processing State = 01, 10, 11 (ON or BENIGN): ADC high pass filter is enabled. |

5.6.6. *ADC0Cnvtr PwrState*

Table 66. ADC0Cnvtr PwrState Command Verb Format

|             | Verb ID | Payload                          | Response           |
|-------------|---------|----------------------------------|--------------------|
| <b>Get</b>  | F05     | 00                               | See bitfield table |
| <b>Set1</b> | 705     | See bits [7:0] of bitfield table | 0000_0000h         |

Table 67. ADC0Cnvtr PwrState Command Response Format

| Bit    | Bitfield Name | RW | Reset | Description   |
|--------|---------------|----|-------|---|
| [31:8] | Rsvd2         | R  | 0x0   | Reserved  |
| [7:4]  | Act           | R  | 0x3   | PS-Act: Actual power state of referenced node.  |
| [3:2]  | Rsvd1         | R  | 0x0   | Reserved  |
| [1:0]  | Set           | RW | 0x3   | PS-Set: Current power setting of referenced node.<br>00 - Fully on.<br>01 - Fully on.<br>10 - Fully on.<br>11 - Powered down (default powered down) |

5.6.7. *ADC0Cnvtr Stream*

Table 68. ADC0Cnvtr Stream Command Verb Format

|             | Verb ID | Payload                          | Response           |
|-------------|---------|----------------------------------|--------------------|
| <b>Get</b>  | F06     | 00                               | See bitfield table |
| <b>Set1</b> | 706     | See bits [7:0] of bitfield table | 0000_0000h         |

Table 69. ADC0Cnvtr Stream Command Response Format

| Bit    | Bitfield Name | RW | Reset | Description |
|--------|---------------|----|-------|-------------|
| [31:8] | Rsvd          | R  | 0x0   | Reserved    |

Table 69. ADC0Cnvtr Stream Command Response Format

| Bit   | Bitfield Name | RW | Reset | Description   |
|-------|---------------|----|-------|---|
| [7:4] | ID            | RW | 0x0   | Software-programmable integer representing link stream ID used by the converter widget. By convention stream 0 is reserved as unused. |
| [3:0] | Ch            | RW | 0x0   | Integer representing lowest channel used by converter   |

## 5.7. SPDIFinCnvtr Node (NID = 0x04)

### 5.7.1. SPDIFinCnvtr Frmt

Table 70. SPDIFinCnvtr Frmt Command Verb Format

|             | Verb ID | Payload                           | Response           |
|-------------|---------|-----------------------------------|--------------------|
| <b>Get</b>  | A       | 0000                              | See bitfield table |
| <b>Set1</b> | 2       | See bits [15:0] of bitfield table | 0000_0000h         |

Table 71. SPDIFinCnvtr Frmt Command Response Format

| Bit     | Bitfield Name | RW | Reset | Description   |
|---------|---------------|----|-------|---|
| [31:16] | Rsvd2         | R  | 0x0   | Reserved  |
| [15]    | StrmType      | RW | 0x0   | N/A.<br>(Stream Type<br>0 = PCM<br>1 = Non-PCM)   |
| [14]    | RateBase      | RW | 0x0   | Sample Base Rate<br>0 = 48 KHz<br>1 = 44.1 KHz  |
| [13:11] | RateMult      | RW | 0x0   | Sample Base Rate Multiple<br>000 = 48 KHz / 44.1 KHz or less<br>001 = x2<br>010 = Reserved (x3)<br>011 = x4<br>100-111 = Reserved |

Table 71. SPDIFinCnvtr Frmt Command Response Format

| Bit    | Bitfield Name | RW | Reset | Description  |
|--------|---------------|----|-------|--|
| [10:8] | RateDiv       | RW | 0x0   | Sample Base Rate Divisor<br>000 = Divide by 1<br>001 = Divide by 2<br>010 = Divide by 3<br>011 = Divide by 4<br>100 = Divide by 5<br>101 = Divide by 6<br>110 = Divide by 7<br>111 = Divide by 8 |
| [7]    | Rsvd1         | R  | 0x0   | Reserved   |
| [6:4]  | NumBits       | RW | 0x3   | Bits per Sample<br>000 = 8 bits<br>001 = 16 bits<br>010 = 20 bits<br>011 = 24 bits<br>100-111 = Reserved   |
| [3:0]  | NumChan       | RW | 0x1   | Number of Channels in each frame of the stream.<br>0000 = 1 channel<br>0001 = 2 channels<br>...<br>1111 = 16 channels  |

### 5.7.2. SPDIFinCnvtr WCap

Table 72. SPDIFinCnvtr WCap Command Verb Format

|            | Verb ID | Payload | Response           |
|------------|---------|---------|--------------------|
| <b>Get</b> | F00     | 09      | See bitfield table |

Table 73. SPDIFinCnvtr WCap Command Response Format

| Bit     | Bitfield Name | RW | Reset | Description                            |
|---------|---------------|----|-------|--|
| [31:24] | Rsvd2         | R  | 0x0   | Reserved                               |
| [23:20] | Type          | R  | 0x1   | Widget type = Audio Input              |
| [19:16] | Delay         | R  | 0x4   | Number of sample delays through widget |
| [15:12] | Rsvd1         | R  | 0x0   | Reserved                               |

Table 73. SPDIFinCnvtr WCap Command Response Format

| Bit  | Bitfield Name | RW | Reset | Description  |
|------|---------------|----|-------|--|
| [11] | SwapCap       | R  | 0x0   | No left/right channel swap capability  |
| [10] | PwrCntrl      | R  | 0x0   | No support for Power State control   |
| [9]  | DigitalStrm   | R  | 0x1   | Widget supports a Digital stream   |
| [8]  | ConnList      | R  | 0x1   | Connection list is present   |
| [7]  | UnsolCap      | R  | 0x0   | No support for Unsolicited Response  |
| [6]  | ProcWidget    | R  | 0x0   | No Processing Controls parameter   |
| [5]  | Stripe        | R  | 0x0   | No support for striping  |
| [4]  | FormatOvrd    | R  | 0x1   | Widget contains format info; software should query                                   |
| [3]  | AmpParamOvrd  | R  | 0x0   | No amplifier info; use default amplifier parameters from Audio Function node instead |
| [2]  | OutAmpPrsnt   | R  | 0x0   | No output amp  |
| [1]  | InAmpPrsnt    | R  | 0x0   | No input amp   |
| [0]  | Stereo        | R  | 0x1   | Stereo widget  |

### 5.7.3. SPDIFinCnvtr FrmtCap

Table 74. SPDIFinCnvtr FrmtCap Command Verb Format

|            | Verb ID | Payload | Response           |
|------------|---------|---------|--------------------|
| <b>Get</b> | F00     | 0A      | See bitfield table |

Table 75. SPDIFinCnvtr FrmtCap Command Response Format

| Bit     | Bitfield Name | RW | Reset | Description                            |
|---------|---------------|----|-------|--|
| [31:21] | Rsvd2         | R  | 0x0   | Reserved                               |
| [20]    | B32           | R  | 0x0   | 32 bit audio formats are NOT supported |
| [19]    | B24           | R  | 0x1   | 24 bit audio formats are supported     |



Table 75. SPDIFinCnvtr FrmtCap Command Response Format

| Bit     | Bitfield Name | RW | Reset | Description                                  |
|---------|---------------|----|-------|--|
| [18]    | B20           | R  | 0x1   | 20 bit audio formats are supported           |
| [17]    | B16           | R  | 0x1   | 16 bit audio formats are supported           |
| [16]    | B8            | R  | 0x0   | 8 bit audio formats are NOT supported        |
| [15:12] | Rsvd1         | R  | 0x0   | Reserved                                     |
| [11]    | R12           | R  | 0x0   | 384 KHz rate (8/1*48 KHz) NOT supported      |
| [10]    | R11           | R  | 0x0   | 192.0 KHz rate (4/1*48 KHz) NOT supported    |
| [9]     | R10           | R  | 0x0   | 176.4 KHz rate (4/1*44.1 KHz) NOT supported  |
| [8]     | R9            | R  | 0x1   | 96.0 KHz rate (2/1*48 KHz) supported         |
| [7]     | R8            | R  | 0x0   | 88.2 KHz rate (2/1*44.1 KHz) NOT supported   |
| [6]     | R7            | R  | 0x1   | 48.0 KHz rate supported (REQUIRED)           |
| [5]     | R6            | R  | 0x1   | 44.1 KHz rate supported                      |
| [4]     | R5            | R  | 0x0   | 32.0 KHz rate (2/3*48 KHz) NOT supported     |
| [3]     | R4            | R  | 0x0   | 22.05 KHz rate (1/2*44.1 KHz) NOT supported  |
| [2]     | R3            | R  | 0x0   | 16.0 KHz rate (1/3*48 KHz) NOT supported     |
| [1]     | R2            | R  | 0x0   | 11.025 KHz rate (1/4*44.0 KHz) NOT supported |
| [0]     | R1            | R  | 0x0   | 8.0 KHz rate (1/6*48 KHz) NOT supported      |

#### 5.7.4. SPDIFinCnvtr StreamCap

Table 76. SPDIFinCnvtr StreamCap Command Verb Format

|            | Verb ID | Payload | Response           |
|------------|---------|---------|--------------------|
| <b>Get</b> | F00     | 0B      | See bitfield table |

Table 77. SPDIFinCnvtr StreamCap Command Response Format

| Bit    | Bitfield Name | RW | Reset | Description                   |
|--------|---------------|----|-------|-------------------------------|
| [31:3] | Rsvd          | R  | 0x0   | Reserved                      |
| [2]    | NonPCM        | R  | 0x1   | Non-PCM data supported.       |
| [1]    | Float32       | R  | 0x0   | No support for Float32 data.  |
| [0]    | PCM           | R  | 0x1   | PCM-formatted data supported. |

### 5.7.5. SPDIFinCnvtr ConnLen

Table 78. SPDIFinCnvtr ConnLen Command Verb Format

|     | Verb ID | Payload | Response           |
|-----|---------|---------|--------------------|
| Get | F00     | 0E      | See bitfield table |

Table 79. SPDIFinCnvtr ConnLen Command Response Format

| Bit    | Bitfield Name | RW | Reset | Description  |
|--------|---------------|----|-------|--|
| [31:8] | Rsvd          | R  | 0x0   | Reserved.  |
| [7]    | LongForm      | R  | 0x0   | Connection list uses short-form (7-bit) NID entries. |
| [6:0]  | N             | R  | 0x01  | Number of NID entries in connection list.            |

### 5.7.6. SPDIFinCnvtr ConnLst

Table 80. SPDIFinCnvtr ConnLst Command Verb Format

|     | Verb ID | Payload | Response           |
|-----|---------|---------|--------------------|
| Get | F02     | 00      | See bitfield table |

Table 81. SPDIFinCnvtr ConnLst Command Response Format

| Bit     | Bitfield Name | RW | Reset | Description        |
|---------|---------------|----|-------|--------------------|
| [31:24] | Entry3        | R  | 0x00  | Unused list entry. |
| [23:16] | Entry2        | R  | 0x00  | Unused list entry. |
| [15:8]  | Entry1        | R  | 0x00  | Unused list entry. |
| [7:0]   | Entry0        | R  | 0x07  | DigIn Pin widget   |

### 5.7.7. SPDIFinCnvtr Stream

Table 82. SPDIFinCnvtr Stream Command Verb Format

|             | Verb ID | Payload                          | Response           |
|-------------|---------|----------------------------------|--------------------|
| <b>Get</b>  | F06     | 00                               | See bitfield table |
| <b>Set1</b> | 706     | See bits [7:0] of bitfield table | 0000_0000h         |

Table 83. SPDIFinCnvtr Stream Command Response Format

| Bit    | Bitfield Name | RW | Reset | Description   |
|--------|---------------|----|-------|---|
| [31:8] | Rsvd          | R  | 0x0   | Reserved  |
| [7:4]  | ID            | RW | 0x0   | Software-programmable integer representing link stream ID used by the converter widget. By convention stream 0 is reserved as unused. |
| [3:0]  | Ch            | RW | 0x0   | Integer representing lowest channel used by converter   |

### 5.7.8. SPDIFinCnvtr DigCtl

Table 84. SPDIFinCnvtr DigCtl Command Verb Format

|            | Verb ID | Payload | Response           |
|------------|---------|---------|--------------------|
| <b>Get</b> | F0D     | 00      | See bitfield table |

Table 84. SPDIFinCnvtr DigCtl Command Verb Format

|             | Verb ID | Payload                           | Response   |
|-------------|---------|-----------------------------------|------------|
| <b>Set1</b> | 70D     | See bits [7:0] of bitfield table  | 0000_0000h |
| <b>Set2</b> | 70E     | See bits [15:8] of bitfield table | 0000_0000h |

Table 85. SPDIFinCnvtr DigCtl Command Response Format

| Bit     | Bitfield Name | RW | Reset | Description  |
|---------|---------------|----|-------|--|
| [31:15] | Rsvd2         | R  | 0x0   | Reserved   |
| [14:8]  | CC            | R  | 0x00  | CC[6:0] - Category Code                            |
| [7]     | L             | R  | 0x0   | L - Generation Level                               |
| [6]     | PRO           | R  | 0x0   | PRO - Professional                                 |
| [5]     | AUDIO         | R  | 0x0   | /AUDIO - Non-Audio                                 |
| [4]     | COPY          | R  | 0x0   | COPY - Copyright                                   |
| [3]     | PRE           | R  | 0x0   | PRE - Preemphasis                                  |
| [2]     | Rsvd1         | R  | 0x0   | Reserved (VCFG bit applies only to output streams) |
| [1]     | V             | R  | 0x0   | V - Validity                                       |
| [0]     | DigEn         | RW | 0x0   | DigEn - Digital Enable                             |

## 5.8. SPDIFoutCnvtr Node (NID = 0x05)

### 5.8.1. SPDIFoutCnvtr Frmt

Table 86. SPDIFoutCnvtr Frmt Command Verb Format

|             | Verb ID | Payload                           | Response           |
|-------------|---------|-----------------------------------|--------------------|
| <b>Get</b>  | A       | 0000                              | See bitfield table |
| <b>Set1</b> | 2       | See bits [15:0] of bitfield table | 0000_0000h         |

Table 87. SPDIFoutCnvtr Frmt Command Response Format

| Bit     | Bitfield Name | RW | Reset | Description  |
|---------|---------------|----|-------|--|
| [31:16] | Rsvd2         | R  | 0x0   | Reserved   |
| [15]    | StrmType      | RW | 0x0   | Stream Type<br>0 = PCM<br>1 = Non-PCM<br>(remaining bits in this verb have other meanings)   |
| [14]    | RateBase      | RW | 0x0   | Sample Base Rate<br>0 = 48 KHz<br>1 = 44.1 KHz   |
| [13:11] | RateMult      | RW | 0x0   | Sample Base Rate Multiple:<br>000 = 48 KHz / 44.1 KHz or less;<br>001 = x2;<br>010 = Reserved (x3);<br>011 = x4;<br>100-111 = Reserved   |
| [10:8]  | RateDiv       | RW | 0x0   | Sample Base Rate Divisor<br>000 = Divide by 1<br>001 = Divide by 2<br>010 = Divide by 3<br>011 = Divide by 4<br>100 = Divide by 5<br>101 = Divide by 6<br>110 = Divide by 7<br>111 = Divide by 8 |
| [7]     | Rsvd1         | R  | 0x0   | Reserved   |
| [6:4]   | NumBits       | RW | 0x3   | Bits per Sample<br>000 = 8 bits<br>001 = 16 bits<br>010 = 20 bits<br>011 = 24 bits<br>100-111 = Reserved   |
| [3:0]   | NumChan       | RW | 0x1   | Number of Channels in each frame of the stream.<br>0000 = 1 channel<br>0001 = 2 channels<br>...<br>1111 = 16 channels  |

## 5.8.2. SPDIFoutCnvtr WCap

Table 88. SPDIFoutCnvtr WCap Command Verb Format

|     | Verb ID | Payload | Response           |
|-----|---------|---------|--------------------|
| Get | F00     | 09      | See bitfield table |

Table 89. SPDIFoutCnvtr WCap Command Response Format

| Bit     | Bitfield Name | RW | Reset | Description  |
|---------|---------------|----|-------|--|
| [31:24] | Rsvd2         | R  | 0x0   | Reserved   |
| [23:20] | Type          | R  | 0x0   | Widget type = Audio Output   |
| [19:16] | Delay         | R  | 0x4   | Number of sample delays through widget   |
| [15:12] | Rsvd1         | R  | 0x0   | Reserved   |
| [11]    | SwapCap       | R  | 0x0   | No left/right channel swap capability  |
| [10]    | PwrCntrl      | R  | 0x0   | No support for Power State control   |
| [9]     | DigitalStrm   | R  | 0x1   | Widget supports a Digital stream   |
| [8]     | ConnList      | R  | 0x0   | No connection list is present  |
| [7]     | UnsolCap      | R  | 0x0   | No support for Unsolicited Response  |
| [6]     | ProcWidget    | R  | 0x0   | No Processing Controls parameter   |
| [5]     | Stripe        | R  | 0x0   | No support for striping  |
| [4]     | FormatOvrd    | R  | 0x1   | Widget contains format info; software should query                                   |
| [3]     | AmpParamOvrd  | R  | 0x0   | No amplifier info; use default amplifier parameters from Audio Function node instead |
| [2]     | OutAmpPrsnt   | R  | 0x0   | No output amp  |
| [1]     | InAmpPrsnt    | R  | 0x0   | No input amp   |
| [0]     | Stereo        | R  | 0x1   | Stereo widget  |

## 5.8.3. SPDIFoutCnvtr FrmtCap

Table 90. SPDIFoutCnvtr FrmtCap Command Verb Format

|     | Verb ID | Payload | Response           |
|-----|---------|---------|--------------------|
| Get | F00     | 0A      | See bitfield table |

Table 91. SPDIFoutCnvtr FrmtCap Command Response Format

| Bit     | Bitfield Name | RW | Reset | Description                                  |
|---------|---------------|----|-------|--|
| [31:21] | Rsvd2         | R  | 0x0   | Reserved                                     |
| [20]    | B32           | R  | 0x0   | 32 bit audio formats are NOT supported       |
| [19]    | B24           | R  | 0x1   | 24 bit audio formats are supported           |
| [18]    | B20           | R  | 0x1   | 20 bit audio formats are supported           |
| [17]    | B16           | R  | 0x1   | 16 bit audio formats are supported           |
| [16]    | B8            | R  | 0x0   | 8 bit audio formats are NOT supported        |
| [15:12] | Rsvd1         | R  | 0x0   | Reserved                                     |
| [11]    | R12           | R  | 0x0   | 384 KHz rate (8/1*48 KHz) NOT supported      |
| [10]    | R11           | R  | 0x0   | 192.0 KHz rate (4/1*48 KHz) NOT supported    |
| [9]     | R10           | R  | 0x0   | 176.4 KHz rate (4/1*44.1 KHz) NOT supported  |
| [8]     | R9            | R  | 0x1   | 96.0 KHz rate (2/1*48 KHz) supported         |
| [7]     | R8            | R  | 0x1   | 88.2 KHz rate (2/1*44.1 KHz) supported       |
| [6]     | R7            | R  | 0x1   | 48.0 KHz rate supported (REQUIRED)           |
| [5]     | R6            | R  | 0x1   | 44.1 KHz rate supported                      |
| [4]     | R5            | R  | 0x0   | 32.0 KHz rate (2/3*48 KHz) NOT supported     |
| [3]     | R4            | R  | 0x0   | 22.05 KHz rate (1/2*44.1 KHz) NOT supported  |
| [2]     | R3            | R  | 0x0   | 16.0 KHz rate (1/3*48 KHz) NOT supported     |
| [1]     | R2            | R  | 0x0   | 11.025 KHz rate (1/4*44.0 KHz) NOT supported |
| [0]     | R1            | R  | 0x0   | 8.0 KHz rate (1/6*48 KHz) NOT supported      |

#### 5.8.4. SPDIFoutCnvtr StreamCap

Table 92. SPDIFoutCnvtr StreamCap Command Verb Format

|     | Verb ID | Payload | Response           |
|-----|---------|---------|--------------------|
| Get | F00     | 0B      | See bitfield table |

Table 93. SPDIFoutCnvtr StreamCap Command Response Format

| Bit    | Bitfield Name | RW | Reset | Description                   |
|--------|---------------|----|-------|-------------------------------|
| [31:3] | Rsvd          | R  | 0x0   | Reserved                      |
| [2]    | NonPCM        | R  | 0x1   | Non-PCM data supported.       |
| [1]    | Float32       | R  | 0x0   | No support for Float32 data.  |
| [0]    | PCM           | R  | 0x1   | PCM-formatted data supported. |

#### 5.8.5. SPDIFoutCnvtr Stream

Table 94. SPDIFoutCnvtr Stream Command Verb Format

|      | Verb ID | Payload                          | Response           |
|------|---------|----------------------------------|--------------------|
| Get  | F06     | 00                               | See bitfield table |
| Set1 | 706     | See bits [7:0] of bitfield table | 0000_0000h         |

Table 95. SPDIFoutCnvtr Stream Command Response Format

| Bit    | Bitfield Name | RW | Reset | Description   |
|--------|---------------|----|-------|---|
| [31:8] | Rsvd          | R  | 0x0   | Reserved  |
| [7:4]  | ID            | RW | 0x0   | Software-programmable integer representing link stream ID used by the converter widget. By convention stream 0 is reserved as unused. |
| [3:0]  | Ch            | RW | 0x0   | Integer representing lowest channel used by converter   |



### 5.8.6. SPDIFoutCnvtr DigCtl

Table 96. SPDIFoutCnvtr DigCtl Command Verb Format

|             | Verb ID | Payload                           | Response           |
|-------------|---------|-----------------------------------|--------------------|
| <b>Get</b>  | F0D     | 00                                | See bitfield table |
| <b>Set1</b> | 70D     | See bits [7:0] of bitfield table  | 0000_0000h         |
| <b>Set2</b> | 70E     | See bits [15:8] of bitfield table | 0000_0000h         |

Table 97. SPDIFoutCnvtr DigCtl Command Response Format

| Bit     | Bitfield Name | RW | Reset | Description             |
|---------|---------------|----|-------|-------------------------|
| [31:16] | Rsvd2         | R  | 0x0   | Reserved                |
| [15]    | Rsvd1         | R  | 0x0   | Rsvd                    |
| [14:8]  | CC            | RW | 0x00  | CC[6:0] - Category Code |
| [7]     | L             | RW | 0x0   | L - Generation Level    |
| [6]     | PRO           | RW | 0x0   | PRO - Professional      |
| [5]     | AUDIO         | RW | 0x0   | /AUDIO - Non-Audio      |
| [4]     | COPY          | RW | 0x0   | COPY - Copyright        |
| [3]     | PRE           | RW | 0x0   | PRE - Preemphasis       |
| [2]     | VCFG          | RW | 0x0   | VCFG - Validity Config  |
| [1]     | V             | RW | 0x0   | V - Validity            |
| [0]     | DigEn         | RW | 0x0   | DigEn - Digital Enable  |

## 5.9. DAC0Mux Node (NID = 0x06)

### 5.9.1. DAC0Mux WCap

Table 98. DAC0Mux WCap Command Verb Format

|            | Verb ID | Payload | Response           |
|------------|---------|---------|--------------------|
| <b>Get</b> | F00     | 09      | See bitfield table |

Table 99. DAC0Mux WCap Command Response Format

| Bit     | Bitfield Name | RW | Reset | Description  |
|---------|---------------|----|-------|--|
| [31:24] | Rsvd2         | R  | 0x0   | Reserved   |
| [23:20] | Type          | R  | 0x3   | Widget type = Audio Selector   |
| [19:16] | Delay         | R  | 0x0   | Number of sample delays through widget   |
| [15:12] | Rsvd1         | R  | 0x0   | Reserved   |
| [11]    | SwapCap       | R  | 0x1   | Left and right channels can be swapped   |
| [10]    | PwrCntrl      | R  | 0x0   | No support for Power State control   |
| [9]     | DigitalStrm   | R  | 0x0   | Widget supports an Analog stream   |
| [8]     | ConnList      | R  | 0x1   | Connection list is present   |
| [7]     | UnsolCap      | R  | 0x0   | No support for Unsolicited Response  |
| [6]     | ProcWidget    | R  | 0x0   | No Processing Controls parameter.  |
| [5]     | Stripe        | R  | 0x0   | No support for striping  |
| [4]     | FormatOvr     | R  | 0x0   | No format info; use default format parameters from Audio Function node instead       |
| [3]     | AmpParamOvr   | R  | 0x0   | No amplifier info; use default amplifier parameters from Audio Function node instead |
| [2]     | OutAmpPrsnt   | R  | 0x0   | No output amp  |
| [1]     | InAmpPrsnt    | R  | 0x0   | No input amp   |
| [0]     | Stereo        | R  | 0x1   | Stereo widget  |

### 5.9.2. DAC0Mux ConnLen

Table 100. DAC0Mux ConnLen Command Verb Format

|            | Verb ID | Payload | Response           |
|------------|---------|---------|--------------------|
| <b>Get</b> | F00     | 0E      | See bitfield table |

Table 101. DAC0Mux ConnLen Command Response Format

| Bit    | Bitfield Name | RW | Reset | Description  |
|--------|---------------|----|-------|--|
| [31:8] | Rsvd          | R  | 0x0   | Reserved.  |
| [7]    | LongForm      | R  | 0x0   | Connection list uses short-form (7-bit) NID entries. |
| [6:0]  | N             | R  | 0x03  | Number of NID entries in connection list.            |

### 5.9.3. DAC0Mux ConnSel

Table 102. DAC0Mux ConnSel Command Verb Format

|             | Verb ID | Payload                          | Response           |
|-------------|---------|----------------------------------|--------------------|
| <b>Get</b>  | F01     | 00                               | See bitfield table |
| <b>Set1</b> | 701     | See bits [7:0] of bitfield table | 0000_0000h         |

Table 103. DAC0Mux ConnSel Command Response Format

| Bit    | Bitfield Name | RW | Reset | Description                      |
|--------|---------------|----|-------|----------------------------------|
| [31:2] | Rsvd          | R  | 0x0   | Reserved                         |
| [1:0]  | Index         | RW | 0x0   | Connection select control index. |

### 5.9.4. DAC0Mux ConnLst

Table 104. DAC0Mux ConnLst Command Verb Format

|            | Verb ID | Payload | Response           |
|------------|---------|---------|--------------------|
| <b>Get</b> | F02     | 00      | See bitfield table |

Table 105. DAC0Mux ConnLst Command Response Format

| Bit     | Bitfield Name | RW | Reset | Description        |
|---------|---------------|----|-------|--------------------|
| [31:24] | Entry3        | R  | 0x00  | Unused list entry. |
| [23:16] | Entry2        | R  | 0x14  | ADC0InMux widget.  |

Table 105. DAC0Mux ConnLst Command Response Format

| Bit    | Bitfield Name | RW | Reset | Description                  |
|--------|---------------|----|-------|------------------------------|
| [15:8] | Entry1        | R  | 0x07  | DigIn Pin widget.            |
| [7:0]  | Entry0        | R  | 0x02  | DAC Analog converter widget. |

### 5.9.5. DAC0Mux LR

Table 106. DAC0Mux LR Command Verb Format

|             | Verb ID | Payload                          | Response           |
|-------------|---------|----------------------------------|--------------------|
| <b>Get</b>  | F0C     | 00                               | See bitfield table |
| <b>Set1</b> | 70C     | See bits [7:0] of bitfield table | 0000_0000h         |

Table 107. DAC0Mux LR Command Response Format

| Bit    | Bitfield Name | RW | Reset | Description                                      |
|--------|---------------|----|-------|--|
| [31:3] | Rsvd2         | R  | 0x0   | Reserved   |
| [2]    | SwapEn        | RW | 0x0   | 1 = swap left and right channels of this Widget. |
| [1:0]  | Rsvd1         | R  | 0x0   | Reserved   |

## 5.10. DigInPin Node (NID = 0x07)

### 5.10.1. DigInPin WCap

Table 108. DigInPin WCap Command Verb Format

|            | Verb ID | Payload | Response           |
|------------|---------|---------|--------------------|
| <b>Get</b> | F00     | 09      | See bitfield table |

Table 109. DigInPin WCap Command Response Format

| Bit     | Bitfield Name | RW | Reset | Description  |
|---------|---------------|----|-------|--|
| [31:24] | Rsvd2         | R  | 0x0   | Reserved   |
| [23:20] | Type          | R  | 0x4   | Widget type = Pin Complex  |
| [19:16] | Delay         | R  | 0x3   | Number of sample delays through widget   |
| [15:12] | Rsvd1         | R  | 0x0   | Reserved   |
| [11]    | SwapCap       | R  | 0x0   | No left/right channel swap capability  |
| [10]    | PwrCntrl      | R  | 0x1   | Power State control is supported   |
| [9]     | DigitalStrm   | R  | 0x1   | Widget supports a Digital stream   |
| [8]     | ConnList      | R  | 0x0   | No connection list is present  |
| [7]     | UnsolCap      | R  | 0x1   | Unsolicited Response is supported  |
| [6]     | ProcWidget    | R  | 0x0   | No Processing Controls parameter   |
| [5]     | Stripe        | R  | 0x0   | No support for striping  |
| [4]     | FormatOvrd    | R  | 0x0   | N/A for pin complex  |
| [3]     | AmpParamOvrd  | R  | 0x0   | No amplifier info; use default amplifier parameters from Audio Function node instead |
| [2]     | OutAmpPrsnt   | R  | 0x0   | No output amp  |
| [1]     | InAmpPrsnt    | R  | 0x0   | No input amp   |
| [0]     | Stereo        | R  | 0x1   | Stereo widget  |

### 5.10.2. DigInPin Cap

Table 110. DigInPin Cap Command Verb Format

|            | Verb ID | Payload | Response           |
|------------|---------|---------|--------------------|
| <b>Get</b> | F00     | 0C      | See bitfield table |

Table 111. DigInPin Cap Command Response Format

| Bit     | Bitfield Name | RW | Reset | Description   |
|---------|---------------|----|-------|---|
| [31:17] | Rsvd2         | R  | 0x0   | Reserved  |
| [16]    | EapdCap       | R  | 0x1   | This widget controls EAPD pin   |
| [15:8]  | VRefCntrl     | R  | 0x00  | VRef generation not supported by this pin complex.                            |
| [7]     | Rsvd1         | R  | 0x0   | Reserved  |
| [6]     | BalancedIO    | R  | 0x0   | Pin complex does not have balanced pins.                                      |
| [5]     | InCap         | R  | 0x1   | Pin complex is input capable.   |
| [4]     | OutCap        | R  | 0x0   | Pin complex is not output capable.<br>(EAPD does not equal the output stream) |
| [3]     | HPhnDrvCap    | R  | 0x0   | Pin does not have a headphone amplifier.                                      |
| [2]     | PresDtctCap   | R  | 0x1   | Pin complex can perform Presence Detect.                                      |
| [1]     | TrigRqd       | R  | 0x0   | N/A   |
| [0]     | ImpSenseCap   | R  | 0x0   | Pin complex does not support impedance sense.                                 |

### 5.10.3. DigInPin PwrState

Table 112. DigInPin PwrState Command Verb Format

|             | Verb ID | Payload                          | Response           |
|-------------|---------|----------------------------------|--------------------|
| <b>Get</b>  | F05     | 00                               | See bitfield table |
| <b>Set1</b> | 705     | See bits [7:0] of bitfield table | 0000_0000h         |

Table 113. DigInPin PwrState Command Response Format

| Bit    | Bitfield Name | RW | Reset | Description                                    |
|--------|---------------|----|-------|--|
| [31:8] | Rsvd2         | R  | 0x0   | Reserved                                       |
| [7:4]  | Act           | R  | 0x3   | PS-Act: Actual power state of referenced node. |

Table 113. DigInPin PwrState Command Response Format

| Bit   | Bitfield Name | RW | Reset | Description   |
|-------|---------------|----|-------|---|
| [3:2] | Rsvd1         | R  | 0x0   | Reserved  |
| [1:0] | Set           | RW | 0x3   | PS-Set: Current power setting of referenced node.<br>00 - Fully on.<br>01 - Fully on.<br>10 - Fully on.<br>11 - Powered down (default powered down) |

#### 5.10.4. DigInPin Ctl

Table 114. DigInPin Ctl Command Verb Format

|             | Verb ID | Payload                          | Response           |
|-------------|---------|----------------------------------|--------------------|
| <b>Get</b>  | F07     | 00                               | See bitfield table |
| <b>Set1</b> | 707     | See bits [7:0] of bitfield table | 0000_0000h         |

Table 115. DigInPin Ctl Command Response Format

| Bit    | Bitfield Name | RW | Reset | Description                                     |
|--------|---------------|----|-------|---|
| [31:6] | Rsvd2         | R  | 0x0   | Reserved  |
| [5]    | InEn          | RW | 0x0   | 1 = (CODEC) input path of Pin Widget is enabled |
| [4:0]  | Rsvd1         | R  | 0x0   | Reserved  |

#### 5.10.5. DigInPin UnsolResp

Table 116. DigInPin UnsolResp Command Verb Format

|             | Verb ID | Payload                          | Response           |
|-------------|---------|----------------------------------|--------------------|
| <b>Get</b>  | F08     | 00                               | See bitfield table |
| <b>Set1</b> | 708     | See bits [7:0] of bitfield table | 0000_0000h         |

Table 117. DigInPin UnsolResp Command Response Format

| Bit    | Bitfield Name | RW | Reset | Description  |
|--------|---------------|----|-------|--|
| [31:8] | Rsvd2         | R  | 0x00  | Reserved   |
| [7]    | En            | RW | 0x0   | Allow generation of Unsolicited Responses. Unsolicited response events occur upon lock or loss-of-lock by SPDIF-in clock recovery circuit. |
| [6]    | Rsvd1         | R  | 0x0   | Reserved.  |
| [5:0]  | Tag           | RW | 0x00  | Software programmable field returned in top six bits (31:26) of every Unsolicited Response generated by this node.                         |

### 5.10.6. DigInPin Sense

Table 118. DigInPin Sense Command Verb Format

|             | Verb ID | Payload                          | Response           |
|-------------|---------|----------------------------------|--------------------|
| <b>Get</b>  | F09     | 00                               | See bitfield table |
| <b>Set1</b> | 709     | See bits [7:0] of bitfield table | 0000_0000h         |
| <b>Set2</b> | 709     | See bits [7:0] of bitfield table | 0000_0000h         |

Table 119. DigInPin Sense Command Response Format

| Bit    | Bitfield Name | RW | Reset | Description  |
|--------|---------------|----|-------|--|
| [31]   | Present       | R  | 0x0   | 1 = something is plugged into jack associated with Pin Complex. For this widget, Presence Detect indicates that the SPDIF-in clock recovery circuit has locked onto a valid SPDIF-in sampling frequency. Any change in status will generate an Unsolicited Response, if enabled with verb 708. |
| [30:0] | Rsvd          | R  | 0x0   | Reserved. Impedance sense not supported for this Pin Complex.  |



### 5.10.7. DigInPin EAPD

Table 120. DigInPin EAPD Command Verb Format

|             | Verb ID | Payload                          | Response           |
|-------------|---------|----------------------------------|--------------------|
| <b>Get</b>  | F0C     | 00                               | See bitfield table |
| <b>Set1</b> | 70C     | See bits [7:0] of bitfield table | 0000_0000h         |

Table 121. DigInPin EAPD Command Response Format

| Bit    | Bitfield Name | RW | Reset | Description   |
|--------|---------------|----|-------|---|
| [31:2] | Rsvd2         | R  | 0x0   | Reserved  |
| [1]    | Data          | RW | 0x0   | EAPD value reflected on the EAPD pin.<br>0 = power down external amp;<br>1 = power up external amp if PwrState < 0x2. If PwrState > = 0x2, Pin47 is Hi-Z.<br>An external pull-down is required if EAPD must be low when Pin Widget is powered down. |
| [0]    | Rsvd1         | R  | 0x0   | Reserved  |

### 5.10.8. DigInPin Config

Table 122. DigInPin Config Command Verb Format

|             | Verb ID | Payload                            | Response           |
|-------------|---------|------------------------------------|--------------------|
| <b>Get</b>  | F1C     | 00                                 | See bitfield table |
| <b>Set1</b> | 71C     | See bits [7:0] of bitfield table   | 0000_0000h         |
| <b>Set2</b> | 71D     | See bits [15:8] of bitfield table  | 0000_0000h         |
| <b>Set3</b> | 71E     | See bits [23:16] of bitfield table | 0000_0000h         |
| <b>Set4</b> | 71F     | See bits [31:24] of bitfield table | 0000_0000h         |

Table 123. DigInPin Config Command Response Format

| Bit     | Bitfield Name | RW | Reset | Description   |
|---------|---------------|----|-------|---|
| [31:30] | Port          | RW | 0x0   | External Port Connectivity of the Pin Complex.<br>0 = Port Complex is connected to a jack                                   |
| [29:24] | Location      | RW | 0x01  | Physical location of the jack. Optical jack at mainboard rear.  |
| [23:20] | Device        | RW | 0xC   | Default Device, indicating intended use of jack. C = SPDIF In   |
| [19:16] | Connection    | RW | 0x5   | Connection Type. 5 = optical  |
| [15:12] | Color         | RW | 0xE   | Color of physical jack. E = White   |
| [11:8]  | Misc          | RW | 0x1   | Misc[0] = Jack Detect override.   |
| [7:4]   | Assoc         | RW | 0x5   | Default Association for Pin Complex groups. Reserved value 0000b should not be used. Value 1111b indicates lowest priority. |
| [3:0]   | Sequence      | RW | 0x0   | All Widgets in an association must have unique sequence number.   |

## 5.11. DigOutPin Node (NID = 0x08)

### 5.11.1. DigOutPin WCap

Table 124. DigOutPin WCap Command Verb Format

|            | Verb ID | Payload | Response           |
|------------|---------|---------|--------------------|
| <b>Get</b> | F00     | 09      | See bitfield table |

Table 125. DigOutPin WCap Command Response Format

| Bit     | Bitfield Name | RW | Reset | Description               |
|---------|---------------|----|-------|---------------------------|
| [31:24] | Rsvd2         | R  | 0x0   | Reserved                  |
| [23:20] | Type          | R  | 0x4   | Widget type = Pin Complex |

Table 125. DigOutPin WCap Command Response Format

| Bit     | Bitfield Name | RW | Reset | Description  |
|---------|---------------|----|-------|--|
| [19:16] | Delay         | R  | 0x0   | Number of sample delays through widget   |
| [15:12] | Rsvd1         | R  | 0x0   | Reserved   |
| [11]    | SwapCap       | R  | 0x0   | No left/right channel swap capability  |
| [10]    | PwrCntrl      | R  | 0x0   | No support for Power State control   |
| [9]     | DigitalStrm   | R  | 0x1   | Widget supports a Digital stream   |
| [8]     | ConnList      | R  | 0x1   | Connection list is present   |
| [7]     | UnsolCap      | R  | 0x0   | No support for Unsolicited Response  |
| [6]     | ProcWidget    | R  | 0x0   | No Processing Controls parameter   |
| [5]     | Stripe        | R  | 0x0   | No support for striping  |
| [4]     | FormatOvrđ    | R  | 0x0   | N/A for pin complex  |
| [3]     | AmpParamOvrđ  | R  | 0x0   | No amplifier info; use default amplifier parameters from Audio Function node instead |
| [2]     | OutAmpPrsnt   | R  | 0x0   | No output amp  |
| [1]     | InAmpPrsnt    | R  | 0x0   | No input amp   |
| [0]     | Stereo        | R  | 0x1   | Stereo widget  |

### 5.11.2. DigOutPin Cap

Table 126. DigOutPin Cap Command Verb Format

|     | Verb ID | Payload | Response           |
|-----|---------|---------|--------------------|
| Get | F00     | 0C      | See bitfield table |

Table 127. DigOutPin Cap Command Response Format

| Bit     | Bitfield Name | RW | Reset | Description                           |
|---------|---------------|----|-------|---------------------------------------|
| [31:17] | Rsvd2         | R  | 0x0   | Reserved                              |
| [16]    | EapđCap       | R  | 0x0   | This widget does not control EAPD pin |

Table 127. DigOutPin Cap Command Response Format

| Bit    | Bitfield Name | RW | Reset | Description   |
|--------|---------------|----|-------|---|
| [15:8] | VRefCntrl     | R  | 0x00  | VRef generation N/A since pin complex is not input capable. |
| [7]    | Rsvd1         | R  | 0x0   | Reserved  |
| [6]    | BalancedIO    | R  | 0x0   | Pin complex does not have balanced pins.                    |
| [5]    | InCap         | R  | 0x0   | Pin complex is not input capable.                           |
| [4]    | OutCap        | R  | 0x1   | Pin complex is output capable.                              |
| [3]    | HPhnDrvCap    | R  | 0x0   | Pin does not have a headphone amplifier.                    |
| [2]    | PresDtctCap   | R  | 0x0   | Pin complex cannot perform Presence Detect.                 |
| [1]    | TrigRqd       | R  | 0x0   | N/A   |
| [0]    | ImpSenseCap   | R  | 0x0   | Pin complex does not support impedance sense.               |

### 5.11.3. DigOutPin ConnLen

Table 128. DigOutPin ConnLen Command Verb Format

|            | Verb ID | Payload | Response           |
|------------|---------|---------|--------------------|
| <b>Get</b> | F00     | 0E      | See bitfield table |

Table 129. DigOutPin ConnLen Command Response Format

| Bit    | Bitfield Name | RW | Reset | Description  |
|--------|---------------|----|-------|--|
| [31:8] | Rsvd          | R  | 0x0   | Reserved.  |
| [7]    | LongForm      | R  | 0x0   | Connection list uses short-form (7-bit) NID entries. |
| [6:0]  | N             | R  | 0x02  | Number of NID entries in connection list.            |

5.11.4. *DigOutPin ConnSel*

Table 130. DigOutPin ConnSel Command Verb Format

|             | Verb ID | Payload                          | Response           |
|-------------|---------|----------------------------------|--------------------|
| <b>Get</b>  | F01     | 00                               | See bitfield table |
| <b>Set1</b> | 701     | See bits [7:0] of bitfield table | 0000_0000h         |

Table 131. DigOutPin ConnSel Command Response Format

| Bit    | Bitfield Name | RW | Reset | Description                      |
|--------|---------------|----|-------|----------------------------------|
| [31:2] | Rsvd          | R  | 0x0   | Reserved                         |
| [1:0]  | Index         | RW | 0x0   | Connection select control index. |

5.11.5. *DigOutPin ConnLst*

Table 132. DigOutPin ConnLst Command Verb Format

|            | Verb ID | Payload | Response           |
|------------|---------|---------|--------------------|
| <b>Get</b> | F02     | 00      | See bitfield table |

Table 133. DigOutPin ConnLst Command Response Format

| Bit     | Bitfield Name | RW | Reset | Description                 |
|---------|---------------|----|-------|-----------------------------|
| [31:24] | Entry3        | R  | 0x00  | Unused list entry.          |
| [23:16] | Entry2        | R  | 0x00  | Unused list entry.          |
| [15:8]  | Entry1        | R  | 0x14  | ADC0InMux widget.           |
| [7:0]   | Entry0        | R  | 0x05  | SPDIF Out converter widget. |

5.11.6. *DigOutPin Ctl*

Table 134. DigOutPin Ctl Command Verb Format

|             | Verb ID | Payload                          | Response           |
|-------------|---------|----------------------------------|--------------------|
| <b>Get</b>  | F07     | 00                               | See bitfield table |
| <b>Set1</b> | 707     | See bits [7:0] of bitfield table | 0000_0000h         |

Table 135. DigOutPin Ctl Command Response Format

| Bit    | Bitfield Name | RW | Reset | Description                                      |
|--------|---------------|----|-------|--|
| [31:7] | Rsvd2         | R  | 0x0   | Reserved   |
| [6]    | OutEn         | RW | 0x0   | 1 = (CODEC) output path of Pin Widget is enabled |
| [5:0]  | Rsvd1         | R  | 0x0   | Reserved   |

5.11.7. *DigOutPin Config*

Table 136. DigOutPin Config Command Verb Format

|             | Verb ID | Payload                            | Response           |
|-------------|---------|------------------------------------|--------------------|
| <b>Get</b>  | F1C     | 00                                 | See bitfield table |
| <b>Set1</b> | 71C     | See bits [7:0] of bitfield table   | 0000_0000h         |
| <b>Set2</b> | 71D     | See bits [15:8] of bitfield table  | 0000_0000h         |
| <b>Set3</b> | 71E     | See bits [23:16] of bitfield table | 0000_0000h         |
| <b>Set4</b> | 71F     | See bits [31:24] of bitfield table | 0000_0000h         |

Table 137. DigOutPin Config Command Response Format

| Bit     | Bitfield Name | RW | Reset | Description   |
|---------|---------------|----|-------|---|
| [31:30] | Port          | RW | 0x0   | External Port Connectivity of the Pin Complex.<br>0 = Port Complex is connected to a jack |
| [29:24] | Location      | RW | 0x01  | Physical location of the jack. Optical jack at mainboard rear.                            |

Table 137. DigOutPin Config Command Response Format

| Bit     | Bitfield Name | RW | Reset | Description   |
|---------|---------------|----|-------|---|
| [23:20] | Device        | RW | 0x4   | Default Device, indicating intended use of jack. 4 = SPDIF Out  |
| [19:16] | Connection    | RW | 0x5   | Connection Type. 5 = optical  |
| [15:12] | Color         | RW | 0x1   | Color of physical jack. 1 = Black   |
| [11:8]  | Misc          | RW | 0x1   | Misc[0] = Jack Detect override.   |
| [7:4]   | Assoc         | RW | 0x3   | Default Association for Pin Complex groups. Reserved value 0000b should not be used. Value 1111b indicates lowest priority. |
| [3:0]   | Sequence      | RW | 0x0   | All Widgets in an association must have unique sequence number.   |

## 5.12. ADC0VolMux Node (NID = 0x09)

### 5.12.1. ADC0VolMux VolRight

Table 138. ADC0VolMux VolRight Command Verb Format

|             | Verb ID | Payload                          | Response           |
|-------------|---------|----------------------------------|--------------------|
| <b>Get</b>  | B80     | 00                               | See bitfield table |
| <b>Set1</b> | 390     | See bits [7:0] of bitfield table | 0000_0000h         |

Table 139. ADC0VolMux VolRight Command Response Format

| Bit    | Bitfield Name | RW | Reset | Description                |
|--------|---------------|----|-------|----------------------------|
| [31:4] | Rsvd1         | R  | 0x0   | Reserved                   |
| [3:0]  | Gain          | RW | 0x0   | Amplifier gain step number |

### 5.12.2. ADC0VolMux VolLeft

Table 140. ADC0VolMux VolLeft Command Verb Format

|             | Verb ID | Payload                          | Response           |
|-------------|---------|----------------------------------|--------------------|
| <b>Get</b>  | BA0     | 00                               | See bitfield table |
| <b>Set1</b> | 3A0     | See bits [7:0] of bitfield table | 0000_0000h         |

Table 141. ADC0VolMux VolLeft Command Response Format

| Bit    | Bitfield Name | RW | Reset | Description                |
|--------|---------------|----|-------|----------------------------|
| [31:4] | Rsvd1         | R  | 0x0   | Reserved                   |
| [3:0]  | Gain          | RW | 0x0   | Amplifier gain step number |

### 5.12.3. ADC0VolMux WCap

Table 142. ADC0VolMux WCap Command Verb Format

|            | Verb ID | Payload | Response           |
|------------|---------|---------|--------------------|
| <b>Get</b> | F00     | 09      | See bitfield table |

Table 143. ADC0VolMux WCap Command Response Format

| Bit     | Bitfield Name | RW | Reset | Description                            |
|---------|---------------|----|-------|--|
| [31:24] | Rsvd2         | R  | 0x0   | Reserved                               |
| [23:20] | Type          | R  | 0x3   | Widget type = Audio Selector           |
| [19:16] | Delay         | R  | 0x0   | Number of sample delays through widget |
| [15:12] | Rsvd1         | R  | 0x0   | Reserved                               |
| [11]    | SwapCap       | R  | 0x0   | No left/right swap capability          |
| [10]    | PwrCntrl      | R  | 0x0   | No support for Power State control     |
| [9]     | DigitalStrm   | R  | 0x0   | Widget supports an Analog stream       |
| [8]     | ConnList      | R  | 0x1   | Connection list is present             |



Table 143. ADC0VolMux WCap Command Response Format

| Bit | Bitfield Name | RW | Reset | Description  |
|-----|---------------|----|-------|--|
| [7] | UnsolCap      | R  | 0x0   | No support for Unsolicited Response  |
| [6] | ProcWidget    | R  | 0x0   | No Processing Controls parameter.  |
| [5] | Stripe        | R  | 0x0   | No support for striping  |
| [4] | FormatOvrd    | R  | 0x0   | No format info; use default format parameters from Audio Function node instead |
| [3] | AmpParamOvrd  | R  | 0x1   | This widget contains its own amplifier parameters.                             |
| [2] | OutAmpPrsnt   | R  | 0x1   | Output amp is present  |
| [1] | InAmpPrsnt    | R  | 0x0   | No input amp   |
| [0] | Stereo        | R  | 0x1   | Stereo widget  |

#### 5.12.4. ADC0VolMux OutAmpCap

Table 144. ADC0VolMux OutAmpCap Command Verb Format

|            | Verb ID | Payload | Response           |
|------------|---------|---------|--------------------|
| <b>Get</b> | F00     | 12      | See bitfield table |

Table 145. ADC0VolMux OutAmpCap Command Response Format

| Bit     | Bitfield Name | RW | Reset | Description  |
|---------|---------------|----|-------|--|
| [31]    | Mute          | R  | 0x0   | Amplifier is not capable of muting                                 |
| [30:23] | Rsvd3         | R  | 0x0   | Reserved   |
| [22:16] | StepSize      | R  | 0x05  | Size of each step in the gain range = 1.5dB                        |
| [15]    | Rsvd2         | R  | 0x0   | Reserved   |
| [14:8]  | NumSteps      | R  | 0x0F  | Number of steps in the gain range = 15 (16 values, 0dB to +22.5dB) |
| [7]     | Rsvd1         | R  | 0x0   | Reserved   |
| [6:0]   | Offset        | R  | 0x00  | 0dB-step is programmed with this offset                            |

5.12.5. *ADC0VolMux ConnLen*

Table 146. ADC0VolMux ConnLen Command Verb Format

|     | Verb ID | Payload | Response           |
|-----|---------|---------|--------------------|
| Get | F00     | 0E      | See bitfield table |

Table 147. ADC0VolMux ConnLen Command Response Format

| Bit    | Bitfield Name | RW | Reset | Description  |
|--------|---------------|----|-------|--|
| [31:8] | Rsvd          | R  | 0x0   | Reserved   |
| [7]    | LongForm      | R  | 0x0   | Connection list uses short-form (7-bit) NID entries. |
| [6:0]  | N             | R  | 0x01  | Number of NID entries in connection list.            |

5.12.6. *ADC0VolMux ConnLst*

Table 148. ADC0VolMux ConnLst Command Verb Format

|     | Verb ID | Payload | Response           |
|-----|---------|---------|--------------------|
| Get | F02     | 00      | See bitfield table |

Table 149. ADC0VolMux ConnLst Command Response Format

| Bit     | Bitfield Name | RW | Reset | Description                       |
|---------|---------------|----|-------|-----------------------------------|
| [31:24] | Entry3        | R  | 0x00  | Unused list entry.                |
| [23:16] | Entry2        | R  | 0x00  | Unused list entry.                |
| [15:8]  | Entry1        | R  | 0x00  | Unused list entry.                |
| [7:0]   | Entry0        | R  | 0x0F  | Input Port (UnivJack) Mux widget. |

## 5.13. MasterVol Node (NID = 0x0E)

### 5.13.1. MasterVol Right

Table 150. MasterVol Right Command Verb Format

|             | Verb ID | Payload                          | Response           |
|-------------|---------|----------------------------------|--------------------|
| <b>Get</b>  | B80     | 00                               | See bitfield table |
| <b>Set1</b> | 390     | See bits [7:0] of bitfield table | 0000_0000h         |

Table 151. MasterVol Right Command Response Format

| Bit    | Bitfield Name | RW | Reset | Description                |
|--------|---------------|----|-------|----------------------------|
| [31:8] | Rsvd2         | R  | 0x0   | Reserved                   |
| [7]    | Mute          | RW | 0x1   | 1 = mute is active         |
| [6:5]  | Rsvd1         | R  | 0x0   | Reserved                   |
| [4:0]  | Gain          | RW | 0x1F  | Amplifier gain step number |

### 5.13.2. MasterVol Left

Table 152. MasterVol Left Command Verb Format

|             | Verb ID | Payload                          | Response           |
|-------------|---------|----------------------------------|--------------------|
| <b>Get</b>  | BA0     | 00                               | See bitfield table |
| <b>Set1</b> | 3A0     | See bits [7:0] of bitfield table | 0000_0000h         |

Table 153. MasterVol Left Command Response Format

| Bit    | Bitfield Name | RW | Reset | Description                |
|--------|---------------|----|-------|----------------------------|
| [31:8] | Rsvd2         | R  | 0x0   | Reserved                   |
| [7]    | Mute          | RW | 0x1   | 1 = mute is active         |
| [6:5]  | Rsvd1         | R  | 0x0   | Reserved                   |
| [4:0]  | Gain          | RW | 0x1F  | Amplifier gain step number |

5.13.3. *MasterVol WCap*

Table 154. MasterVol WCap Command Verb Format

|     | Verb ID | Payload | Response           |
|-----|---------|---------|--------------------|
| Get | F00     | 09      | See bitfield table |

Table 155. MasterVol WCap Command Response Format

| Bit     | Bitfield Name | RW | Reset | Description  |
|---------|---------------|----|-------|--|
| [31:24] | Rsvd2         | R  | 0x0   | Reserved   |
| [23:20] | Type          | R  | 0x3   | Widget type = Audio Selector   |
| [19:16] | Delay         | R  | 0x0   | Number of sample delays through widget   |
| [15:12] | Rsvd1         | R  | 0x0   | Reserved   |
| [11]    | SwapCap       | R  | 0x0   | No left/right channel swap capability  |
| [10]    | PwrCntrl      | R  | 0x0   | No support for Power State control   |
| [9]     | DigitalStrm   | R  | 0x0   | Widget supports an Analog stream   |
| [8]     | ConnList      | R  | 0x1   | Connection list is present   |
| [7]     | UnsolCap      | R  | 0x0   | No support for Unsolicited Response  |
| [6]     | ProcWidget    | R  | 0x0   | No Processing Controls parameter.  |
| [5]     | Stripe        | R  | 0x0   | No support for striping  |
| [4]     | FormatOvrd    | R  | 0x0   | No format info; use default format parameters from Audio Function node instead       |
| [3]     | AmpParamOvrd  | R  | 0x0   | No amplifier info; use default amplifier parameters from Audio Function node instead |
| [2]     | OutAmpPrsnt   | R  | 0x1   | Output amp is present  |
| [1]     | InAmpPrsnt    | R  | 0x0   | No input amp   |
| [0]     | Stereo        | R  | 0x1   | Stereo widget  |

### 5.13.4. MasterVol ConnLen

Table 156. MasterVol ConnLen Command Verb Format

|     | Verb ID | Payload | Response           |
|-----|---------|---------|--------------------|
| Get | F00     | 0E      | See bitfield table |

Table 157. MasterVol ConnLen Command Response Format

| Bit    | Bitfield Name | RW | Reset | Description  |
|--------|---------------|----|-------|--|
| [31:8] | Rsvd          | R  | 0x0   | Reserved   |
| [7]    | LongForm      | R  | 0x0   | Connection list uses short-form (7-bit) NID entries. |
| [6:0]  | N             | R  | 0x01  | Number of NID entries in connection list.            |

### 5.13.5. MasterVol ConnLst

Table 158. MasterVol ConnLst Command Verb Format

|     | Verb ID | Payload | Response           |
|-----|---------|---------|--------------------|
| Get | F02     | 00      | See bitfield table |

Table 159. MasterVol ConnLst Command Response Format

| Bit     | Bitfield Name | RW | Reset | Description        |
|---------|---------------|----|-------|--------------------|
| [31:24] | Entry3        | R  | 0x00  | Unused list entry. |
| [23:16] | Entry2        | R  | 0x00  | Unused list entry. |
| [15:8]  | Entry1        | R  | 0x00  | Unused list entry. |
| [7:0]   | Entry0        | R  | 0x06  | DAC Mux widget.    |

## 5.14. InPortMux Node (NID = 0x0F)

### 5.14.1. InPortMux VolRight

Table 160. InPortMux VolRight Command Verb Format

|             | Verb ID | Payload                          | Response           |
|-------------|---------|----------------------------------|--------------------|
| <b>Get</b>  | B80     | 00                               | See bitfield table |
| <b>Set1</b> | 390     | See bits [7:0] of bitfield table | 0000_0000h         |

Table 161. InPortMux VolRight Command Response Format

| Bit    | Bitfield Name | RW | Reset | Description                |
|--------|---------------|----|-------|----------------------------|
| [31:3] | Rsvd          | R  | 0x0   | Reserved                   |
| [2:0]  | Gain          | RW | 0x0   | Amplifier gain step number |

### 5.14.2. InPortMux VolLeft

Table 162. InPortMux VolLeft Command Verb Format

|             | Verb ID | Payload                          | Response           |
|-------------|---------|----------------------------------|--------------------|
| <b>Get</b>  | BA0     | 00                               | See bitfield table |
| <b>Set1</b> | 3A0     | See bits [7:0] of bitfield table | 0000_0000h         |

Table 163. InPortMux VolLeft Command Response Format

| Bit    | Bitfield Name | RW | Reset | Description                |
|--------|---------------|----|-------|----------------------------|
| [31:3] | Rsvd          | R  | 0x0   | Reserved                   |
| [2:0]  | Gain          | RW | 0x0   | Amplifier gain step number |

### 5.14.3. InPortMux WCap

Table 164. InPortMux WCap Command Verb Format

|            | Verb ID | Payload | Response           |
|------------|---------|---------|--------------------|
| <b>Get</b> | F00     | 09      | See bitfield table |

Table 165. InPortMux WCap Command Response Format

| Bit     | Bitfield Name | RW | Reset | Description  |
|---------|---------------|----|-------|--|
| [31:24] | Rsvd2         | R  | 0x0   | Reserved   |
| [23:20] | Type          | R  | 0x3   | Widget type = Audio Selector   |
| [19:16] | Delay         | R  | 0x0   | Number of sample delays through widget   |
| [15:12] | Rsvd1         | R  | 0x0   | Reserved   |
| [11]    | SwapCap       | R  | 0x0   | No left/right channel swap capability  |
| [10]    | PwrCntrl      | R  | 0x0   | No support for Power State control   |
| [9]     | DigitalStrm   | R  | 0x0   | Widget supports an Analog stream   |
| [8]     | ConnList      | R  | 0x1   | Connection list is present   |
| [7]     | UnsolCap      | R  | 0x0   | No support for Unsolicited Response  |
| [6]     | ProcWidget    | R  | 0x0   | No Processing Controls parameter.  |
| [5]     | Stripe        | R  | 0x0   | No support for striping  |
| [4]     | FormatOvrd    | R  | 0x0   | No format info; use default format parameters from Audio Function node instead |
| [3]     | AmpParamOvrd  | R  | 0x1   | This widget contains its own amplifier parameters.                             |
| [2]     | OutAmpPrsnt   | R  | 0x1   | Output amp is present  |
| [1]     | InAmpPrsnt    | R  | 0x0   | No input amp   |
| [0]     | Stereo        | R  | 0x1   | Stereo widget  |

#### 5.14.4. InPortMux ConnLen

Table 166. InPortMux ConnLen Command Verb Format

|            | Verb ID | Payload | Response           |
|------------|---------|---------|--------------------|
| <b>Get</b> | F00     | 0E      | See bitfield table |

Table 167. InPortMux ConnLen Command Response Format

| Bit    | Bitfield Name | RW | Reset | Description  |
|--------|---------------|----|-------|--|
| [31:8] | Rsvd          | R  | 0x0   | Reserved   |
| [7]    | LongForm      | R  | 0x0   | Connection list uses short-form (7-bit) NID entries. |
| [6:0]  | N             | R  | 0x05  | Number of NID entries in connection list.            |

#### 5.14.5. InPortMux AmpCap

Table 168. InPortMux AmpCap Command Verb Format

|     | Verb ID | Payload | Response           |
|-----|---------|---------|--------------------|
| Get | F00     | 12      | See bitfield table |

Table 169. InPortMux AmpCap Command Response Format

| Bit     | Bitfield Name | RW | Reset | Description   |
|---------|---------------|----|-------|---|
| [31]    | Mute          | R  | 0x0   | No mute capability  |
| [30:23] | Rsvd3         | R  | 0x0   | Reserved  |
| [22:16] | StepSize      | R  | 0x27  | Size of each step in the gain range = 10dB                        |
| [15]    | Rsvd2         | R  | 0x0   | Reserved  |
| [14:8]  | NumSteps      | R  | 0x04  | Number of steps in the gain range = 4<br>(5 values, 0dB to +40dB) |
| [7]     | Rsvd1         | R  | 0x0   | Reserved  |
| [6:0]   | Offset        | R  | 0x00  | 0dB-step is programmed with this offset                           |



### 5.14.6. InPortMux ConnSel

Table 170. InPortMux ConnSel Command Verb Format

|             | Verb ID | Payload                          | Response           |
|-------------|---------|----------------------------------|--------------------|
| <b>Get</b>  | F01     | 00                               | See bitfield table |
| <b>Set1</b> | 701     | See bits [7:0] of bitfield table | 0000_0000h         |

Table 171. InPortMux ConnSel Command Response Format

| Bit    | Bitfield Name | RW | Reset | Description                      |
|--------|---------------|----|-------|----------------------------------|
| [31:3] | Rsvd          | R  | 0x0   | Reserved                         |
| [2:0]  | Index         | RW | 0x0   | Connection select control index. |

### 5.14.7. InPortMux ConnLst0

Table 172. InPortMux ConnLst0 Command Verb Format

|            | Verb ID | Payload | Response           |
|------------|---------|---------|--------------------|
| <b>Get</b> | F02     | 00      | See bitfield table |

Table 173. InPortMux ConnLst0 Command Response Format

| Bit     | Bitfield Name | RW | Reset | Description        |
|---------|---------------|----|-------|--------------------|
| [31:24] | Entry3        | R  | 0x0A  | Port A pin widget. |
| [23:16] | Entry2        | R  | 0x0D  | Port D pin widget. |
| [15:8]  | Entry1        | R  | 0x0C  | Port C pin widget. |
| [7:0]   | Entry0        | R  | 0x0B  | Port B pin widget. |

### 5.14.8. InPortMux ConnLst4

Table 174. InPortMux ConnLst4 Command Verb Format

|            | Verb ID | Payload | Response           |
|------------|---------|---------|--------------------|
| <b>Get</b> | F02     | 04      | See bitfield table |

Table 175. InPortMux ConnLst4 Command Response Format

| Bit     | Bitfield Name | RW | Reset | Description        |
|---------|---------------|----|-------|--------------------|
| [31:24] | Entry3        | R  | 0x00  | Unused list entry. |
| [23:16] | Entry2        | R  | 0x00  | Unused list entry. |
| [15:8]  | Entry1        | R  | 0x00  | Unused list entry. |
| [7:0]   | Entry0        | R  | 0x11  | CDin pin widget.   |

## 5.15. PortAPin Node (NID = 0x0A)

### 5.15.1. PortAPin WCap

Table 176. PortAPin WCap Command Verb Format

|            | Verb ID | Payload | Response           |
|------------|---------|---------|--------------------|
| <b>Get</b> | F00     | 09      | See bitfield table |

Table 177. PortAPin WCap Command Response Format

| Bit     | Bitfield Name | RW | Reset | Description                            |
|---------|---------------|----|-------|--|
| [31:24] | Rsvd2         | R  | 0x0   | Reserved                               |
| [23:20] | Type          | R  | 0x4   | Widget type = Pin Complex              |
| [19:16] | Delay         | R  | 0x0   | Number of sample delays through widget |
| [15:12] | Rsvd1         | R  | 0x0   | Reserved                               |
| [11]    | SwapCap       | R  | 0x0   | No left/right channel swap capability  |
| [10]    | PwrCntrl      | R  | 0x0   | No support for Power State control     |
| [9]     | DigitalStrm   | R  | 0x0   | Widget supports an Analog stream       |
| [8]     | ConnList      | R  | 0x1   | Connection list is present             |
| [7]     | UnsolCap      | R  | 0x1   | Unsolicited Response is supported      |
| [6]     | ProcWidget    | R  | 0x0   | No Processing Controls parameter       |

Table 177. PortAPin WCap Command Response Format

| Bit | Bitfield Name | RW | Reset | Description   |
|-----|---------------|----|-------|---|
| [5] | Stripe        | R  | 0x0   | No support for striping   |
| [4] | FormatOvrd    | R  | 0x0   | N/A for pin complex   |
| [3] | AmpParamOvrd  | R  | 0x0   | No amplifier info; use default amplifier parameters from Audio Function node instead. |
| [2] | OutAmpPrsnt   | R  | 0x0   | No output amp   |
| [1] | InAmpPrsnt    | R  | 0x0   | No input amp  |
| [0] | Stereo        | R  | 0x1   | Stereo widget   |

### 5.15.2. PortAPin Cap

Table 178. PortAPin Cap Command Verb Format

|            | Verb ID | Payload | Response           |
|------------|---------|---------|--------------------|
| <b>Get</b> | F00     | 0C      | See bitfield table |

Table 179. PortAPin Cap Command Response Format

| Bit     | Bitfield Name | RW | Reset | Description  |
|---------|---------------|----|-------|--|
| [31:17] | Rsvd2         | R  | 0x0   | Reserved   |
| [16]    | EapdCap       | R  | 0x0   | This widget does not control EAPD pin              |
| [15:8]  | VRefCntrl     | R  | 0x00  | VRef generation not supported by this pin complex. |
| [7]     | Rsvd1         | R  | 0x0   | Reserved   |
| [6]     | BalancedIO    | R  | 0x0   | Pin complex does not have balanced pins.           |
| [5]     | InCap         | R  | 0x1   | Pin complex is input capable.                      |
| [4]     | OutCap        | R  | 0x1   | Pin complex is output capable.                     |
| [3]     | HPhnDrvCap    | R  | 0x1   | Pin complex has headphone amplifier.               |
| [2]     | PresDtctCap   | R  | 0x1   | Pin complex can perform Presence Detect.           |

Table 179. PortAPin Cap Command Response Format

| Bit | Bitfield Name | RW | Reset | Description                                   |
|-----|---------------|----|-------|---|
| [1] | TrigRqd       | R  | 0x1   | Trigger is required for impedance measurement |
| [0] | ImpSenseCap   | R  | 0x1   | Pin complex supports impedance sense.         |

### 5.15.3. PortAPin ConnLen

Table 180. PortAPin ConnLen Command Verb Format

|     | Verb ID | Payload | Response           |
|-----|---------|---------|--------------------|
| Get | F00     | 0E      | See bitfield table |

Table 181. PortAPin ConnLen Command Response Format

| Bit    | Bitfield Name | RW | Reset | Description  |
|--------|---------------|----|-------|--|
| [31:8] | Rsvd          | R  | 0x0   | Reserved.  |
| [7]    | LongForm      | R  | 0x0   | Connection list uses short-form (7-bit) NID entries. |
| [6:0]  | N             | R  | 0x01  | Number of NID entries in connection list.            |

### 5.15.4. PortAPin ConnLst

Table 182. PortAPin ConnLst Command Verb Format

|     | Verb ID | Payload | Response           |
|-----|---------|---------|--------------------|
| Get | F02     | 00      | See bitfield table |

Table 183. PortAPin ConnLst Command Response Format

| Bit     | Bitfield Name | RW | Reset | Description           |
|---------|---------------|----|-------|-----------------------|
| [31:24] | Entry3        | R  | 0x00  | Unused list entry.    |
| [23:16] | Entry2        | R  | 0x00  | Unused list entry.    |
| [15:8]  | Entry1        | R  | 0x00  | Unused list entry.    |
| [7:0]   | Entry0        | R  | 0x0E  | Master Volume widget. |

5.15.5. *PortAPin Ctl*

Table 184. PortAPin Ctl Command Verb Format

|             | Verb ID | Payload                          | Response           |
|-------------|---------|----------------------------------|--------------------|
| <b>Get</b>  | F07     | 00                               | See bitfield table |
| <b>Set1</b> | 707     | See bits [7:0] of bitfield table | 0000_0000h         |

Table 185. PortAPin Ctl Command Response Format

| Bit    | Bitfield Name | RW | Reset | Description   |
|--------|---------------|----|-------|---|
| [31:8] | Rsvd2         | R  | 0x0   | Reserved  |
| [7]    | HPhnEn        | RW | 0x0   | 1 = enable the low impedance amplifier associated with the output |
| [6]    | OutEn         | RW | 0x0   | 1 = (CODEC) output path of Pin Widget is enabled                  |
| [5]    | InEn          | RW | 0x0   | 1 = (CODEC) input path of Pin Widget is enabled                   |
| [4:0]  | Rsvd1         | R  | 0x0   | Reserved  |

5.15.6. *PortAPin UnsolicitedResp*

Table 186. PortAPin UnsolicitedResp Command Verb Format

|             | Verb ID | Payload                          | Response           |
|-------------|---------|----------------------------------|--------------------|
| <b>Get</b>  | F08     | 00                               | See bitfield table |
| <b>Set1</b> | 708     | See bits [7:0] of bitfield table | 0000_0000h         |

Table 187. PortAPin UnsolicitedResp Command Response Format

| Bit    | Bitfield Name | RW | Reset | Description   |
|--------|---------------|----|-------|---|
| [31:8] | Rsvd2         | R  | 0x00  | Reserved  |
| [7]    | En            | RW | 0x0   | Allow generation of Unsolicited Responses. Unsolicited response events occur upon jack-insertion OR completion of a Jack-Sense cycle. |

Table 187. PortAPin Unsolicited Command Response Format

| Bit   | Bitfield Name | RW | Reset | Description  |
|-------|---------------|----|-------|--|
| [6]   | Rsvd1         | R  | 0x0   | Reserved   |
| [5:0] | Tag           | RW | 0x00  | Software programmable field returned in top six bits (31:26) of every Unsolicited Response generated by this node. |

### 5.15.7. PortAPin Sense

Table 188. PortAPin Sense Command Verb Format

|             | Verb ID | Payload                          | Response           |
|-------------|---------|----------------------------------|--------------------|
| <b>Get</b>  | F09     | 00                               | See bitfield table |
| <b>Set1</b> | 709     | See bits [7:0] of bitfield table | 0000_0000h         |
| <b>Set2</b> | 709     | See bits [7:0] of bitfield table | 0000_0000h         |

Table 189. PortAPin Sense Command Response Format

| Bit    | Bitfield Name | RW | Reset       | Description   |
|--------|---------------|----|-------------|---|
| [31]   | Present       | R  | 0x0         | 1 = something is plugged into jack associated with Pin Complex.   |
| [30:0] | Impedance     | R  | 0x7FFF_FFFF | Measured impedance of the widget. A value of all 1's indicates that a valid sense reading is not available, or the sense measurement is busy if it has been recently triggered. Overlaps RightCh. |
| [0]    | RightCh       | W  | 0x0         | Set 1 = perform impedance sensing on right channel or ring of the connector   |
| [0]    | LeftCh        | W  | 0x0         | Set 0 = perform impedance sensing on left channel or tip of the connector   |

## 5.15.8. PortAPin Config

Table 190. PortAPin Config Command Verb Format

|             | Verb ID | Payload                            | Response           |
|-------------|---------|------------------------------------|--------------------|
| <b>Get</b>  | F1C     | 00                                 | See bitfield table |
| <b>Set1</b> | 71C     | See bits [7:0] of bitfield table   | 0000_0000h         |
| <b>Set2</b> | 71D     | See bits [15:8] of bitfield table  | 0000_0000h         |
| <b>Set3</b> | 71E     | See bits [23:16] of bitfield table | 0000_0000h         |
| <b>Set4</b> | 71F     | See bits [31:24] of bitfield table | 0000_0000h         |

Table 191. PortAPin Config Command Response Format

| Bit     | Bitfield Name | RW | Reset | Description   |
|---------|---------------|----|-------|---|
| [31:30] | Port          | RW | 0x0   | External Port Connectivity of the Pin Complex.<br>0 = Port Complex is connected to a jack   |
| [29:24] | Location      | RW | 0x02  | Physical location of the jack.<br>02h = Mainboard, Front  |
| [23:20] | Device        | RW | 0x2   | Default Device, indicating intended use of jack. 2 = HP Out   |
| [19:16] | Connection    | RW | 0x1   | Connection Type. 1 = 1/8 inch jack  |
| [15:12] | Color         | RW | 0x4   | Color of physical jack. 4 = Green   |
| [11:8]  | Misc          | RW | 0x0   | Misc[0] = Jack Detect override.   |
| [7:4]   | Assoc         | RW | 0x1   | Default Association for Pin Complex groups.<br>Reserved value 0000b should not be used.<br>Value 1111b indicates lowest priority. |
| [3:0]   | Sequence      | RW | 0xF   | All Widgets in an association must have unique sequence number.   |

## 5.16. PortDPin Node (NID = 0x0D)

### 5.16.1. PortDPin WCap

Table 192. PortDPin WCap Command Verb Format

|     | Verb ID | Payload | Response           |
|-----|---------|---------|--------------------|
| Get | F00     | 09      | See bitfield table |

Table 193. PortDPin WCap Command Response Format

| Bit     | Bitfield Name | RW | Reset | Description   |
|---------|---------------|----|-------|---|
| [31:24] | Rsvd2         | R  | 0x0   | Reserved  |
| [23:20] | Type          | R  | 0x4   | Widget type = Pin Complex   |
| [19:16] | Delay         | R  | 0x0   | Number of sample delays through widget  |
| [15:12] | Rsvd1         | R  | 0x0   | Reserved  |
| [11]    | SwapCap       | R  | 0x0   | No left/right channel swap capability   |
| [10]    | PwrCntrl      | R  | 0x0   | No support for Power State control  |
| [9]     | DigitalStrm   | R  | 0x0   | Widget supports an Analog stream  |
| [8]     | ConnList      | R  | 0x1   | Connection list is present  |
| [7]     | UnsolCap      | R  | 0x1   | Unsolicited Response is supported   |
| [6]     | ProcWidget    | R  | 0x0   | No Processing Controls parameter  |
| [5]     | Stripe        | R  | 0x0   | No support for striping   |
| [4]     | FormatOvrd    | R  | 0x0   | N/A for pin complex   |
| [3]     | AmpParamOvrd  | R  | 0x0   | No amplifier info; use default amplifier parameters from Audio Function node instead. |
| [2]     | OutAmpPrsnt   | R  | 0x0   | No output amp   |
| [1]     | InAmpPrsnt    | R  | 0x0   | No input amp  |
| [0]     | Stereo        | R  | 0x1   | Stereo widget   |



### 5.16.2. PortDPin Cap

Table 194. PortDPin Cap Command Verb Format

|     | Verb ID | Payload | Response           |
|-----|---------|---------|--------------------|
| Get | F00     | 0C      | See bitfield table |

Table 195. PortDPin Cap Command Response Format

| Bit     | Bitfield Name | RW | Reset | Description  |
|---------|---------------|----|-------|--|
| [31:17] | Rsvd2         | R  | 0x0   | Reserved2  |
| [16]    | EapdCap       | R  | 0x0   | This widget does not control EAPD pin              |
| [15:8]  | VRefCntrl     | R  | 0x00  | VRef generation not supported by this pin complex. |
| [7]     | Rsvd1         | R  | 0x0   | Reserved   |
| [6]     | BalancedIO    | R  | 0x0   | Pin complex does not have balanced pins.           |
| [5]     | InCap         | R  | 0x1   | Pin complex is input capable.                      |
| [4]     | OutCap        | R  | 0x1   | Pin complex is output capable.                     |
| [3]     | HPhnDrvCap    | R  | 0x1   | Pin complex has headphone amplifier.               |
| [2]     | PresDtctCap   | R  | 0x1   | Pin complex can perform Presence Detect.           |
| [1]     | TrigRqd       | R  | 0x1   | Trigger is required for impedance measurement      |
| [0]     | ImpSenseCap   | R  | 0x1   | Pin complex supports impedance sense.              |

### 5.16.3. PortDPin ConnLen

Table 196. PortDPin ConnLen Command Verb Format

|     | Verb ID | Payload | Response           |
|-----|---------|---------|--------------------|
| Get | F00     | 0E      | See bitfield table |

Table 197. PortDPin ConnLen Command Response Format

| Bit    | Bitfield Name | RW | Reset | Description  |
|--------|---------------|----|-------|--|
| [31:8] | Rsvd          | R  | 0x0   | Reserved.  |
| [7]    | LongForm      | R  | 0x0   | Connection list uses short-form (7-bit) NID entries. |
| [6:0]  | N             | R  | 0x01  | Number of NID entries in connection list.            |

#### 5.16.4. PortDPin ConnLst

Table 198. PortDPin ConnLst Command Verb Format

|     | Verb ID | Payload | Response           |
|-----|---------|---------|--------------------|
| Get | F02     | 00      | See bitfield table |

Table 199. PortDPin ConnLst Command Response Format

| Bit     | Bitfield Name | RW | Reset | Description           |
|---------|---------------|----|-------|-----------------------|
| [31:24] | Entry3        | R  | 0x00  | Unused list entry.    |
| [23:16] | Entry2        | R  | 0x00  | Unused list entry.    |
| [15:8]  | Entry1        | R  | 0x00  | Unused list entry.    |
| [7:0]   | Entry0        | R  | 0x0E  | Master Volume widget. |

#### 5.16.5. PortDPin Ctl

Table 200. PortDPin Ctl Command Verb Format

|      | Verb ID | Payload                          | Response           |
|------|---------|----------------------------------|--------------------|
| Get  | F07     | 00                               | See bitfield table |
| Set1 | 707     | See bits [7:0] of bitfield table | 0000_0000h         |

Table 201. PortDPin Ctl Command Response Format

| Bit    | Bitfield Name | RW | Reset | Description   |
|--------|---------------|----|-------|---|
| [31:8] | Rsvd2         | R  | 0x0   | Reserved  |
| [7]    | HPhnEn        | RW | 0x0   | 1 = enable the low impedance amplifier associated with the output |
| [6]    | OutEn         | RW | 0x0   | 1 = (CODEC) output path of Pin Widget is enabled                  |
| [5]    | InEn          | RW | 0x0   | 1 = (CODEC) input path of Pin Widget is enabled                   |
| [4:0]  | Rsvd1         | R  | 0x0   | Reserved  |

### 5.16.6. PortDPin Unsolicited Response

Table 202. PortDPin Unsolicited Response Command Verb Format

|             | Verb ID | Payload                          | Response           |
|-------------|---------|----------------------------------|--------------------|
| <b>Get</b>  | F08     | 00                               | See bitfield table |
| <b>Set1</b> | 708     | See bits [7:0] of bitfield table | 0000_0000h         |

Table 203. PortDPin Unsolicited Response Command Response Format

| Bit    | Bitfield Name | RW | Reset | Description   |
|--------|---------------|----|-------|---|
| [31:8] | Rsvd2         | R  | 0x00  | Reserved  |
| [7]    | En            | RW | 0x0   | Allow generation of Unsolicited Responses. Unsolicited response events occur upon jack-insertion OR completion of a Jack-Sense cycle. |
| [6]    | Rsvd1         | R  | 0x0   | Reserved  |
| [5:0]  | Tag           | RW | 0x00  | Software programmable field returned in top six bits (31:26) of every Unsolicited Response generated by this node.                    |

### 5.16.7. PortDPin Sense

Table 204. PortDPin Sense Command Verb Format

|             | Verb ID | Payload                          | Response           |
|-------------|---------|----------------------------------|--------------------|
| <b>Get</b>  | F09     | 00                               | See bitfield table |
| <b>Set1</b> | 709     | See bits [7:0] of bitfield table | 0000_0000h         |
| <b>Set2</b> | 709     | See bits [7:0] of bitfield table | 0000_0000h         |

Table 205. PortDPin Sense Command Response Format

| Bit    | Bitfield Name | RW | Reset       | Description   |
|--------|---------------|----|-------------|---|
| [31]   | Present       | R  | 0x0         | 1 = something is plugged into jack associated with Pin Complex.   |
| [30:0] | Impedance     | R  | 0x7FFF_FFFF | Measured impedance of the widget. A value of all 1's indicates that a valid sense reading is not available, or the sense measurement is busy if it has been recently triggered. Overlaps RightCh. |
| [0]    | RightCh       | W  | 0x0         | Set 1 = perform impedance sensing on right channel or ring of the connector   |
| [0]    | LeftCh        | W  | 0x0         | Set 0 = perform impedance sensing on left channel or tip of the connector   |

### 5.16.8. PortDPin Config

Table 206. PortDPin Config Command Verb Format

|             | Verb ID | Payload                            | Response           |
|-------------|---------|------------------------------------|--------------------|
| <b>Get</b>  | F1C     | 00                                 | See bitfield table |
| <b>Set1</b> | 71C     | See bits [7:0] of bitfield table   | 0000_0000h         |
| <b>Set2</b> | 71D     | See bits [15:8] of bitfield table  | 0000_0000h         |
| <b>Set3</b> | 71E     | See bits [23:16] of bitfield table | 0000_0000h         |
| <b>Set4</b> | 71F     | See bits [31:24] of bitfield table | 0000_0000h         |

Table 207. PortDPin Config Command Response Format

| Bit     | Bitfield Name | RW | Reset | Description   |
|---------|---------------|----|-------|---|
| [31:30] | Port          | RW | 0x0   | External Port Connectivity of the Pin Complex.<br>0 = Port Complex is connected to a jack   |
| [29:24] | Location      | RW | 0x01  | Physical location of the jack.<br>01h = Mainboard, Rear   |
| [23:20] | Device        | RW | 0x0   | Default Device, indicating intended use of jack. 0 = Line Out   |
| [19:16] | Connection    | RW | 0x1   | Connection Type. 1 = 1/8 inch jack  |
| [15:12] | Color         | RW | 0x4   | Color of physical jack. 4 = Green   |
| [11:8]  | Misc          | RW | 0x0   | Misc[0] = Jack Detect override.   |
| [7:4]   | Assoc         | RW | 0x1   | Default Association for Pin Complex groups.<br>Reserved value 0000b should not be used.<br>Value 1111b indicates lowest priority. |
| [3:0]   | Sequence      | RW | 0x0   | All Widgets in an association must have unique sequence number.   |

## 5.17. PortCPin Node (NID = 0x0C)

### 5.17.1. PortCPin WCap

Table 208. PortCPin WCap Command Verb Format

|            | Verb ID | Payload | Response           |
|------------|---------|---------|--------------------|
| <b>Get</b> | F00     | 09      | See bitfield table |

Table 209. PortCPin WCap Command Response Format

| Bit     | Bitfield Name | RW | Reset | Description               |
|---------|---------------|----|-------|---------------------------|
| [31:24] | Rsvd2         | R  | 0x0   | Reserved                  |
| [23:20] | Type          | R  | 0x4   | Widget type = Pin Complex |

Table 209. PortCPin WCap Command Response Format

| Bit     | Bitfield Name | RW | Reset | Description   |
|---------|---------------|----|-------|---|
| [19:16] | Delay         | R  | 0x0   | Number of sample delays through widget  |
| [15:12] | Rsvd1         | R  | 0x0   | Reserved  |
| [11]    | SwapCap       | R  | 0x0   | No left/right channel swap capability   |
| [10]    | PwrCntrl      | R  | 0x0   | No support for Power State control  |
| [9]     | DigitalStrm   | R  | 0x0   | Widget supports an Analog stream  |
| [8]     | ConnList      | R  | 0x1   | Connection list is present  |
| [7]     | UnsolCap      | R  | 0x1   | Unsolicited Response is supported   |
| [6]     | ProcWidget    | R  | 0x0   | No Processing Controls parameter  |
| [5]     | Stripe        | R  | 0x0   | No support for striping   |
| [4]     | FormatOvrd    | R  | 0x0   | N/A for pin complex   |
| [3]     | AmpParamOvrd  | R  | 0x0   | No amplifier info; use default amplifier parameters from Audio Function node instead. |
| [2]     | OutAmpPrsnt   | R  | 0x0   | No output amp   |
| [1]     | InAmpPrsnt    | R  | 0x0   | No input amp  |
| [0]     | Stereo        | R  | 0x1   | Stereo widget   |

### 5.17.2. PortCPin Cap

Table 210. PortCPin Cap Command Verb Format

|     | Verb ID | Payload | Response           |
|-----|---------|---------|--------------------|
| Get | F00     | 0C      | See bitfield table |

Table 211. PortCPin Cap Command Response Format

| Bit     | Bitfield Name | RW | Reset | Description                           |
|---------|---------------|----|-------|---------------------------------------|
| [31:17] | Rsvd2         | R  | 0x0   | Reserved2                             |
| [16]    | EapdCap       | R  | 0x0   | This widget does not control EAPD pin |

Table 211. PortCPin Cap Command Response Format

| Bit    | Bitfield Name | RW | Reset | Description   |
|--------|---------------|----|-------|---|
| [15:8] | VRefCntrl     | R  | 0x17  | VRef generation is supported by this pin complex, and the following voltages can be produced on the associated VRef pin: 80% Avdd; 50% Avdd; GND; Hi-Z (required since pin complex is output capable) |
| [7]    | Rsvd1         | R  | 0x0   | Reserved  |
| [6]    | BalancedIO    | R  | 0x0   | Pin complex does not have balanced pins.  |
| [5]    | InCap         | R  | 0x1   | Pin complex is input capable.   |
| [4]    | OutCap        | R  | 0x1   | Pin complex is output capable.  |
| [3]    | HPhnDrvCap    | R  | 0x0   | Pin does not have a headphone amplifier.  |
| [2]    | PresDtctCap   | R  | 0x1   | Pin complex can perform Presence Detect.  |
| [1]    | TrigRqd       | R  | 0x1   | Trigger is required for impedance measurement   |
| [0]    | ImpSenseCap   | R  | 0x1   | Pin complex supports impedance sense.   |

### 5.17.3. PortCPin ConnLen

Table 212. PortCPin ConnLen Command Verb Format

|            | Verb ID | Payload | Response           |
|------------|---------|---------|--------------------|
| <b>Get</b> | F00     | 0E      | See bitfield table |

Table 213. PortCPin ConnLen Command Response Format

| Bit    | Bitfield Name | RW | Reset | Description  |
|--------|---------------|----|-------|--|
| [31:8] | Rsvd          | R  | 0x0   | Reserved   |
| [7]    | LongForm      | R  | 0x0   | Connection list uses short-form (7-bit) NID entries. |
| [6:0]  | N             | R  | 0x01  | Number of NID entries in connection list.            |

5.17.4. *PortCPin ConnLst*

Table 214. PortCPin ConnLst Command Verb Format

|            | Verb ID | Payload | Response           |
|------------|---------|---------|--------------------|
| <b>Get</b> | F02     | 00      | See bitfield table |

Table 215. PortCPin ConnLst Command Response Format

| Bit     | Bitfield Name | RW | Reset | Description           |
|---------|---------------|----|-------|-----------------------|
| [31:24] | Entry3        | R  | 0x00  | Unused list entry.    |
| [23:16] | Entry2        | R  | 0x00  | Unused list entry.    |
| [15:8]  | Entry1        | R  | 0x00  | Unused list entry.    |
| [7:0]   | Entry0        | R  | 0x0E  | Master Volume widget. |

5.17.5. *PortCPin Ctl*

Table 216. PortCPin Ctl Command Verb Format

|             | Verb ID | Payload                          | Response           |
|-------------|---------|----------------------------------|--------------------|
| <b>Get</b>  | F07     | 00                               | See bitfield table |
| <b>Set1</b> | 707     | See bits [7:0] of bitfield table | 0000_0000h         |

Table 217. PortCPin Ctl Command Response Format

| Bit    | Bitfield Name | RW | Reset | Description                                      |
|--------|---------------|----|-------|--|
| [31:7] | Rsvd2         | R  | 0x0   | Reserved   |
| [6]    | OutEn         | RW | 0x0   | 1 = (CODEC) output path of Pin Widget is enabled |
| [5]    | InEn          | RW | 0x1   | 1 = (CODEC) input path of Pin Widget is enabled  |



Table 217. PortCPin Ctl Command Response Format

| Bit   | Bitfield Name | RW | Reset | Description   |
|-------|---------------|----|-------|---|
| [4:3] | Rsvd1         | R  | 0x0   | Reserved  |
| [2:0] | VRefSelect    | RW | 0x0   | VRefEn: Selects one of the possible states for the VRef signal associated with the Pin Widget. If the value written to this control does not correspond to a supported value defined in the VRefCntrl field of the Pin Capabilities parameter (0C), then this control will take the value of 000b (Hi-Z). |

### 5.17.6. PortCPin Unsolicited Response

Table 218. PortCPin Unsolicited Response Command Verb Format

|             | Verb ID | Payload                          | Response           |
|-------------|---------|----------------------------------|--------------------|
| <b>Get</b>  | F08     | 00                               | See bitfield table |
| <b>Set1</b> | 708     | See bits [7:0] of bitfield table | 0000_0000h         |

Table 219. PortCPin Unsolicited Response Command Response Format

| Bit    | Bitfield Name | RW | Reset | Description   |
|--------|---------------|----|-------|---|
| [31:8] | Rsvd2         | R  | 0x00  | Reserved  |
| [7]    | En            | RW | 0x0   | Allow generation of Unsolicited Responses. Unsolicited response events occur upon jack-insertion OR completion of a Jack-Sense cycle. |
| [6]    | Rsvd1         | R  | 0x0   | Reserved  |
| [5:0]  | Tag           | RW | 0x00  | Software programmable field returned in top six bits (31:26) of every Unsolicited Response generated by this node.                    |

### 5.17.7. PortCPin Sense

Table 220. PortCPin Sense Command Verb Format

|             | Verb ID | Payload                          | Response           |
|-------------|---------|----------------------------------|--------------------|
| <b>Get</b>  | F09     | 00                               | See bitfield table |
| <b>Set1</b> | 709     | See bits [7:0] of bitfield table | 0000_0000h         |
| <b>Set2</b> | 709     | See bits [7:0] of bitfield table | 0000_0000h         |

Table 221. PortCPin Sense Command Response Format

| Bit    | Bitfield Name | RW | Reset       | Description   |
|--------|---------------|----|-------------|---|
| [31]   | Present       | R  | 0x0         | 1 = something is plugged into jack associated with Pin Complex.   |
| [30:0] | Impedance     | R  | 0x7FFF_FFFF | Measured impedance of the widget. A value of all 1's indicates that a valid sense reading is not available, or the sense measurement is busy if it has been recently triggered. Overlaps RightCh. |
| [0]    | RightCh       | W  | 0x0         | Set 1 = perform impedance sensing on right channel or ring of the connector   |
| [0]    | LeftCh        | W  | 0x0         | Set 0 = perform impedance sensing on left channel or tip of the connector   |

### 5.17.8. PortCPin Config

Table 222. PortCPin Config Command Verb Format

|             | Verb ID | Payload                            | Response           |
|-------------|---------|------------------------------------|--------------------|
| <b>Get</b>  | F1C     | 00                                 | See bitfield table |
| <b>Set1</b> | 71C     | See bits [7:0] of bitfield table   | 0000_0000h         |
| <b>Set2</b> | 71D     | See bits [15:8] of bitfield table  | 0000_0000h         |
| <b>Set3</b> | 71E     | See bits [23:16] of bitfield table | 0000_0000h         |
| <b>Set4</b> | 71F     | See bits [31:24] of bitfield table | 0000_0000h         |

Table 223. PortCPin Config Command Response Format

| Bit     | Bitfield Name | RW | Reset | Description   |
|---------|---------------|----|-------|---|
| [31:30] | Port          | RW | 0x0   | External Port Connectivity of the Pin Complex.<br>0 = Port Complex is connected to a jack   |
| [29:24] | Location      | RW | 0x01  | Physical location of the jack.<br>03h = Mainboard, Rear   |
| [23:20] | Device        | RW | 0x8   | Default Device, indicating intended use of jack.<br>8 = Line In   |
| [19:16] | Connection    | RW | 0x1   | Connection Type. 1 = 1/8 inch jack  |
| [15:12] | Color         | RW | 0x3   | Color of physical jack. 3 = Blue  |
| [11:8]  | Misc          | RW | 0x0   | Misc[0] = Jack Detect override.   |
| [7:4]   | Assoc         | RW | 0x2   | Default Association for Pin Complex groups.<br>Reserved value 0000b should not be used. Value<br>1111b indicates lowest priority. |
| [3:0]   | Sequence      | RW | 0x1   | All Widgets in an association must have unique<br>sequence number.  |

## 5.18. PortBPin Node (NID = 0x0B)

### 5.18.1. PortBPin WCap

Table 224. PortBPin WCap Command Verb Format

|     | Verb ID | Payload | Response           |
|-----|---------|---------|--------------------|
| Get | F00     | 09      | See bitfield table |

Table 225. PortBPin WCap Command Response Format

| Bit     | Bitfield Name | RW | Reset | Description                            |
|---------|---------------|----|-------|--|
| [31:24] | Rsvd2         | R  | 0x0   | Reserved                               |
| [23:20] | Type          | R  | 0x4   | Widget type = Pin Complex              |
| [19:16] | Delay         | R  | 0x0   | Number of sample delays through widget |

Table 225. PortBPin WCap Command Response Format

| Bit     | Bitfield Name | RW | Reset | Description   |
|---------|---------------|----|-------|---|
| [15:12] | Rsvd1         | R  | 0x0   | Reserved  |
| [11]    | SwapCap       | R  | 0x0   | No left/right channel swap capability   |
| [10]    | PwrCntrl      | R  | 0x0   | No support for Power State control  |
| [9]     | DigitalStrm   | R  | 0x0   | Widget supports an Analog stream  |
| [8]     | ConnList      | R  | 0x1   | Connection list is present  |
| [7]     | UnsolCap      | R  | 0x1   | Unsolicited Response is supported   |
| [6]     | ProcWidget    | R  | 0x0   | No Processing Controls parameter  |
| [5]     | Stripe        | R  | 0x0   | No support for striping   |
| [4]     | FormatOvr     | R  | 0x0   | N/A for pin complex   |
| [3]     | AmpParamOvr   | R  | 0x0   | No amplifier info; use default amplifier parameters from Audio Function node instead. |
| [2]     | OutAmpPrsnt   | R  | 0x0   | No output amp   |
| [1]     | InAmpPrsnt    | R  | 0x0   | No input amp  |
| [0]     | Stereo        | R  | 0x1   | Stereo widget   |

### 5.18.2. PortBPin Cap

Table 226. PortBPin Cap Command Verb Format

|            | Verb ID | Payload | Response           |
|------------|---------|---------|--------------------|
| <b>Get</b> | F00     | 0C      | See bitfield table |

Table 227. PortBPin Cap Command Response Format

| Bit     | Bitfield Name | RW | Reset | Description                           |
|---------|---------------|----|-------|---------------------------------------|
| [31:17] | Rsvd2         | R  | 0x0   | Reserved                              |
| [16]    | EapdCap       | R  | 0x0   | This widget does not control EAPD pin |

Table 227. PortBPin Cap Command Response Format

| Bit    | Bitfield Name | RW | Reset | Description   |
|--------|---------------|----|-------|---|
| [15:8] | VRefCntrl     | R  | 0x17  | VRef generation is supported by this pin complex, and the following voltages can be produced on the associated VRef pin: 80% Avdd; 50% Avdd; GND; Hi-Z (required since pin complex is output capable) |
| [7]    | Rsvd1         | R  | 0x0   | Reserved  |
| [6]    | BalancedIO    | R  | 0x0   | Pin complex does not have balanced pins.  |
| [5]    | InCap         | R  | 0x1   | Pin complex is input capable.   |
| [4]    | OutCap        | R  | 0x1   | Pin complex is output capable.  |
| [3]    | HPhnDrvCap    | R  | 0x0   | Pin does not have a headphone amplifier.  |
| [2]    | PresDtctCap   | R  | 0x1   | Pin complex can perform Presence Detect.  |
| [1]    | TrigRqd       | R  | 0x1   | Trigger is required for impedance measurement   |
| [0]    | ImpSenseCap   | R  | 0x1   | Pin complex supports impedance sense.   |

### 5.18.3. PortBPin ConnLen

Table 228. PortBPin ConnLen Command Verb Format

|            | Verb ID | Payload | Response           |
|------------|---------|---------|--------------------|
| <b>Get</b> | F00     | 0E      | See bitfield table |

Table 229. PortBPin ConnLen Command Response Format

| Bit    | Bitfield Name | RW | Reset | Description  |
|--------|---------------|----|-------|--|
| [31:8] | Rsvd          | R  | 0x0   | Reserved.  |
| [7]    | LongForm      | R  | 0x0   | Connection list uses short-form (7-bit) NID entries. |
| [6:0]  | N             | R  | 0x01  | Number of NID entries in connection list.            |

5.18.4. *PortBPin ConnLst*

Table 230. PortBPin ConnLst Command Verb Format

|            | Verb ID | Payload | Response           |
|------------|---------|---------|--------------------|
| <b>Get</b> | F02     | 00      | See bitfield table |

Table 231. PortBPin ConnLst Command Response Format

| Bit     | Bitfield Name | RW | Reset | Description           |
|---------|---------------|----|-------|-----------------------|
| [31:24] | Entry3        | R  | 0x00  | Unused list entry.    |
| [23:16] | Entry2        | R  | 0x00  | Unused list entry.    |
| [15:8]  | Entry1        | R  | 0x00  | Unused list entry.    |
| [7:0]   | Entry0        | R  | 0x0E  | Master Volume widget. |

5.18.5. *PortBPin Ctl*

Table 232. PortBPin Ctl Command Verb Format

|             | Verb ID | Payload                          | Response           |
|-------------|---------|----------------------------------|--------------------|
| <b>Get</b>  | F07     | 00                               | See bitfield table |
| <b>Set1</b> | 707     | See bits [7:0] of bitfield table | 0000_0000h         |

Table 233. PortBPin Ctl Command Response Format

| Bit    | Bitfield Name | RW | Reset | Description                                      |
|--------|---------------|----|-------|--|
| [31:7] | Rsvd2         | R  | 0x0   | Reserved   |
| [6]    | OutEn         | RW | 0x0   | 1 = (CODEC) output path of Pin Widget is enabled |
| [5]    | InEn          | RW | 0x1   | 1 = (CODEC) input path of Pin Widget is enabled  |

Table 233. PortBPin Ctl Command Response Format

| Bit   | Bitfield Name | RW | Reset | Description   |
|-------|---------------|----|-------|---|
| [4:3] | Rsvd1         | R  | 0x0   | Reserved  |
| [2:0] | VRefSelect    | RW | 0x0   | VRefEn: Selects one of the possible states for the VRef signal associated with the Pin Widget. If the value written to this control does not correspond to a supported value defined in the VRefCntrl field of the Pin Capabilities parameter (0C), then this control will take the value of 000b (Hi-Z). |

### 5.18.6. PortBPin UnsolResp

Table 234. PortBPin UnsolResp Command Verb Format

|             | Verb ID | Payload                          | Response           |
|-------------|---------|----------------------------------|--------------------|
| <b>Get</b>  | F08     | 00                               | See bitfield table |
| <b>Set1</b> | 708     | See bits [7:0] of bitfield table | 0000_0000h         |

Table 235. PortBPin UnsolResp Command Response Format

| Bit    | Bitfield Name | RW | Reset | Description   |
|--------|---------------|----|-------|---|
| [31:8] | Rsvd2         | R  | 0x00  | Reserved  |
| [7]    | En            | RW | 0x0   | Allow generation of Unsolicited Responses. Unsolicited response events occur upon jack-insertion OR completion of a Jack-Sense cycle. |
| [6]    | Rsvd1         | R  | 0x0   | Reserved  |
| [5:0]  | Tag           | RW | 0x00  | Software programmable field returned in top six bits (31:26) of every Unsolicited Response generated by this node.                    |

### 5.18.7. PortBPin Sense

Table 236. PortBPin Sense Command Verb Format

|             | Verb ID | Payload                          | Response           |
|-------------|---------|----------------------------------|--------------------|
| <b>Get</b>  | F09     | 00                               | See bitfield table |
| <b>Set1</b> | 709     | See bits [7:0] of bitfield table | 0000_0000h         |
| <b>Set2</b> | 709     | See bits [7:0] of bitfield table | 0000_0000h         |

Table 237. PortBPin Sense Command Response Format

| Bit    | Bitfield Name | RW | Reset       | Description   |
|--------|---------------|----|-------------|---|
| [31]   | Present       | R  | 0x0         | 1 = something is plugged into jack associated with Pin Complex.   |
| [30:0] | Impedance     | R  | 0x7FFF_FFFF | Measured impedance of the widget. A value of all 1's indicates that a valid sense reading is not available, or the sense measurement is busy if it has been recently triggered. Overlaps RightCh. |
| [0]    | RightCh       | W  | 0x0         | Set 1 = perform impedance sensing on right channel or ring of the connector   |
| [0]    | LeftCh        | W  | 0x0         | Set 0 = perform impedance sensing on left channel or tip of the connector   |

### 5.18.8. PortBPin Config

Table 238. PortBPin Config Command Verb Format

|             | Verb ID | Payload                            | Response           |
|-------------|---------|------------------------------------|--------------------|
| <b>Get</b>  | F1C     | 00                                 | See bitfield table |
| <b>Set1</b> | 71C     | See bits [7:0] of bitfield table   | 0000_0000h         |
| <b>Set2</b> | 71D     | See bits [15:8] of bitfield table  | 0000_0000h         |
| <b>Set3</b> | 71E     | See bits [23:16] of bitfield table | 0000_0000h         |
| <b>Set4</b> | 71F     | See bits [31:24] of bitfield table | 0000_0000h         |



Table 239. PortBPin Config Command Response Format

| Bit     | Bitfield Name | RW | Reset | Description   |
|---------|---------------|----|-------|---|
| [31:30] | Port          | RW | 0x0   | External Port Connectivity of the Pin Complex.<br>0 = Port Complex is connected to a jack   |
| [29:24] | Location      | RW | 0x02  | Physical location of the jack.<br>02h = Mainboard, Front  |
| [23:20] | Device        | RW | 0xA   | Default Device, indicating intended use of jack.<br>A = Mic In  |
| [19:16] | Connection    | RW | 0x1   | Connection Type. 1 = 1/8 inch jack  |
| [15:12] | Color         | RW | 0x9   | Color of physical jack. 9 = Pink  |
| [11:8]  | Misc          | RW | 0x0   | Misc[0] = Jack Detect override.   |
| [7:4]   | Assoc         | RW | 0x2   | Default Association for Pin Complex groups.<br>Reserved value 0000b should not be used. Value<br>1111b indicates lowest priority. |
| [3:0]   | Sequence      | RW | 0x0   | All Widgets in an association must have unique<br>sequence number.  |

## 5.19. MonoOutPin Node (NID = 0x10)

### 5.19.1. MonoOutPin Vol

Table 240. MonoOutPin Vol Command Verb Format

|             | Verb ID | Payload                          | Response           |
|-------------|---------|----------------------------------|--------------------|
| <b>Get</b>  | BA0     | 00                               | See bitfield table |
| <b>Set1</b> | 3A0     | See bits [7:0] of bitfield table | 0000_0000h         |

Table 241. MonoOutPin Vol Command Response Format

| Bit    | Bitfield Name | RW | Reset | Description        |
|--------|---------------|----|-------|--------------------|
| [31:8] | Rsvd2         | R  | 0x0   | Reserved           |
| [7]    | Mute          | RW | 0x1   | 1 = mute is active |

Table 241. MonoOutPin Vol Command Response Format

| Bit   | Bitfield Name | RW | Reset | Description                            |
|-------|---------------|----|-------|--|
| [6:5] | Rsvd1         | R  | 0x0   | Reserved                               |
| [4:0] | Gain          | RW | 0x1F  | Mono (left) amplifier gain step number |

### 5.19.2. MonoOutPin WCap

Table 242. MonoOutPin WCap Command Verb Format

|            | Verb ID | Payload | Response           |
|------------|---------|---------|--------------------|
| <b>Get</b> | F00     | 09      | See bitfield table |

Table 243. MonoOutPin WCap Command Response Format

| Bit     | Bitfield Name | RW | Reset | Description   |
|---------|---------------|----|-------|---|
| [31:24] | Rsvd2         | R  | 0x0   | Reserved  |
| [23:20] | Type          | R  | 0x4   | Widget type = Pin Complex   |
| [19:16] | Delay         | R  | 0x0   | Number of sample delays through widget  |
| [15:12] | Rsvd1         | R  | 0x0   | Reserved  |
| [11]    | SwapCap       | R  | 0x0   | No left/right channel swap capability   |
| [10]    | PwrCntrl      | R  | 0x0   | No support for Power State control  |
| [9]     | DigitalStrm   | R  | 0x0   | Widget supports an Analog stream  |
| [8]     | ConnList      | R  | 0x1   | Connection list is present  |
| [7]     | UnsolCap      | R  | 0x0   | No support for Unsolicited Response   |
| [6]     | ProcWidget    | R  | 0x0   | No Processing Controls parameter  |
| [5]     | Stripe        | R  | 0x0   | No support for striping   |
| [4]     | FormatOvrd    | R  | 0x0   | N/A for pin complex   |
| [3]     | AmpParamOvrd  | R  | 0x0   | No amplifier info; use default amplifier parameters from Audio Function node instead. |
| [2]     | OutAmpPrsnt   | R  | 0x1   | Output amp is present   |

Table 243. MonoOutPin WCap Command Response Format

| Bit | Bitfield Name | RW | Reset | Description  |
|-----|---------------|----|-------|--------------|
| [1] | InAmpPrsnt    | R  | 0x0   | No input amp |
| [0] | Stereo        | R  | 0x0   | Mono widget  |

### 5.19.3. MonoOutPin Cap

Table 244. MonoOutPin Cap Command Verb Format

|     | Verb ID | Payload | Response           |
|-----|---------|---------|--------------------|
| Get | F00     | 0C      | See bitfield table |

Table 245. MonoOutPin Cap Command Response Format

| Bit     | Bitfield Name | RW | Reset | Description   |
|---------|---------------|----|-------|---|
| [31:17] | Rsvd2         | R  | 0x0   | Reserved  |
| [16]    | EapdCap       | R  | 0x0   | This widget does not control EAPD pin                       |
| [15:8]  | VRefCntrl     | R  | 0x00  | VRef generation N/A since pin complex is not input capable. |
| [7]     | Rsvd1         | R  | 0x0   | Reserved  |
| [6]     | BalancedIO    | R  | 0x0   | Pin complex does not have balanced pins.                    |
| [5]     | InCap         | R  | 0x0   | Pin complex is not input capable.                           |
| [4]     | OutCap        | R  | 0x1   | Pin complex is output capable.                              |
| [3]     | HPhnDrvCap    | R  | 0x0   | Pin does not have a headphone amplifier.                    |
| [2]     | PresDtctCap   | R  | 0x0   | Pin complex cannot perform Presence Detect.                 |
| [1]     | TrigRqd       | R  | 0x0   | N/A   |
| [0]     | ImpSenseCap   | R  | 0x0   | Pin complex does not support impedance sense.               |

#### 5.19.4. MonoOutPin ConnLen

Table 246. MonoOutPin ConnLen Command Verb Format

|     | Verb ID | Payload | Response           |
|-----|---------|---------|--------------------|
| Get | F00     | 0E      | See bitfield table |

Table 247. MonoOutPin ConnLen Command Response Format

| Bit    | Bitfield Name | RW | Reset | Description  |
|--------|---------------|----|-------|--|
| [31:8] | Rsvd          | R  | 0x0   | Reserved   |
| [7]    | LongForm      | R  | 0x0   | Connection list uses short-form (7-bit) NID entries. |
| [6:0]  | N             | R  | 0x01  | Number of NID entries in connection list.            |

#### 5.19.5. MonoOutPin ConnLst

Table 248. MonoOutPin ConnLst Command Verb Format

|     | Verb ID | Payload | Response           |
|-----|---------|---------|--------------------|
| Get | F02     | 00      | See bitfield table |

Table 249. MonoOutPin ConnLst Command Response Format

| Bit     | Bitfield Name | RW | Reset | Description         |
|---------|---------------|----|-------|---------------------|
| [31:24] | Entry3        | R  | 0x00  | Unused list entry.  |
| [23:16] | Entry2        | R  | 0x00  | Unused list entry.  |
| [15:8]  | Entry1        | R  | 0x00  | Unused list entry.  |
| [7:0]   | Entry0        | R  | 0x12  | MonoOut Mix widget. |

### 5.19.6. MonoOutPin Ctl

Table 250. MonoOutPin Ctl Command Verb Format

|             | Verb ID | Payload                          | Response           |
|-------------|---------|----------------------------------|--------------------|
| <b>Get</b>  | F07     | 00                               | See bitfield table |
| <b>Set1</b> | 707     | See bits [7:0] of bitfield table | 0000_0000h         |

Table 251. MonoOutPin Ctl Command Response Format

| Bit    | Bitfield Name | RW | Reset | Description                                      |
|--------|---------------|----|-------|--|
| [31:7] | Rsvd2         | R  | 0x0   | Reserved   |
| [6]    | OutEn         | RW | 0x0   | 1 = (CODEC) output path of Pin Widget is enabled |
| [5:0]  | Rsvd1         | R  | 0x0   | Reserved   |

### 5.19.7. MonoOutPin Config

Table 252. MonoOutPin Config Command Verb Format

|             | Verb ID | Payload                            | Response           |
|-------------|---------|------------------------------------|--------------------|
| <b>Get</b>  | F1C     | 00                                 | See bitfield table |
| <b>Set1</b> | 71C     | See bits [7:0] of bitfield table   | 0000_0000h         |
| <b>Set2</b> | 71D     | See bits [15:8] of bitfield table  | 0000_0000h         |
| <b>Set3</b> | 71E     | See bits [23:16] of bitfield table | 0000_0000h         |
| <b>Set4</b> | 71F     | See bits [31:24] of bitfield table | 0000_0000h         |

Table 253. MonoOutPin Config Command Response Format

| Bit     | Bitfield Name | RW | Reset | Description  |
|---------|---------------|----|-------|--|
| [31:30] | Port          | RW | 0x1   | External Port Connectivity of the Pin Complex.<br>1 = no physical connection |
| [29:24] | Location      | RW | 0x10  | Physical location of the jack. 10h = Internal, N/A                           |

Table 253. MonoOutPin Config Command Response Format

| Bit     | Bitfield Name | RW | Reset | Description   |
|---------|---------------|----|-------|---|
| [23:20] | Device        | RW | 0x0   | Default Device, indicating intended use of jack. 0 = Line Out   |
| [19:16] | Connection    | RW | 0x7   | Connection Type. 7 = Other Analog   |
| [15:12] | Color         | RW | 0x0   | Color of physical jack. 0 = Unknown   |
| [11:8]  | Misc          | RW | 0x1   | Misc[0] = Jack Detect override.   |
| [7:4]   | Assoc         | RW | 0xF   | Default Association for Pin Complex groups. Reserved value 0000b should not be used. Value 1111b indicates lowest priority. |
| [3:0]   | Sequence      | RW | 0x0   | All Widgets in an association must have unique sequence number.   |

## 5.20. CDPin Node (NID = 0x11)

### 5.20.1. CDPin WCap

Table 254. CDPin WCap Command Verb Format

|     | Verb ID | Payload | Response           |
|-----|---------|---------|--------------------|
| Get | F00     | 09      | See bitfield table |

Table 255. CDPin WCap Command Response Format

| Bit     | Bitfield Name | RW | Reset | Description                            |
|---------|---------------|----|-------|--|
| [31:24] | Rsvd2         | R  | 0x0   | Reserved                               |
| [23:20] | Type          | R  | 0x4   | Widget type = Pin Complex              |
| [19:16] | Delay         | R  | 0x0   | Number of sample delays through widget |
| [15:12] | Rsvd1         | R  | 0x0   | Reserved                               |
| [11]    | SwapCap       | R  | 0x0   | No left/right channel swap capability  |
| [10]    | PwrCntrl      | R  | 0x0   | No support for Power State control     |
| [9]     | DigitalStrm   | R  | 0x0   | Widget supports an Analog stream       |

Table 255. CDPin WCap Command Response Format

| Bit | Bitfield Name | RW | Reset | Description   |
|-----|---------------|----|-------|---|
| [8] | ConnList      | R  | 0x0   | No connection list is present   |
| [7] | UnsolCap      | R  | 0x0   | No support for Unsolicited Response   |
| [6] | ProcWidget    | R  | 0x0   | No Processing Controls parameter  |
| [5] | Stripe        | R  | 0x0   | No support for striping   |
| [4] | FormatOvrd    | R  | 0x0   | N/A for pin complex   |
| [3] | AmpParamOvrd  | R  | 0x0   | No amplifier info; use default amplifier parameters from Audio Function node instead. |
| [2] | OutAmpPrsnt   | R  | 0x0   | No output amp   |
| [1] | InAmpPrsnt    | R  | 0x0   | No input amp  |
| [0] | Stereo        | R  | 0x1   | Stereo widget   |

### 5.20.2. CDPin Cap

Table 256. CDPin Cap Command Verb Format

|            | Verb ID | Payload | Response           |
|------------|---------|---------|--------------------|
| <b>Get</b> | F00     | 0C      | See bitfield table |

Table 257. CDPin Cap Command Response Format

| Bit     | Bitfield Name | RW | Reset | Description  |
|---------|---------------|----|-------|--|
| [31:17] | Rsvd2         | R  | 0x0   | Reserved   |
| [16]    | EapdCap       | R  | 0x0   | This widget does not control EAPD pin              |
| [15:8]  | VRefCntrl     | R  | 0x00  | VRef generation not supported by this pin complex. |
| [7]     | Rsvd1         | R  | 0x0   | Reserved   |
| [6]     | BalancedIO    | R  | 0x0   | Pin complex does not have balanced pins.           |
| [5]     | InCap         | R  | 0x1   | Pin complex is input capable.                      |

Table 257. CDPin Cap Command Response Format

| Bit | Bitfield Name | RW | Reset | Description                                   |
|-----|---------------|----|-------|---|
| [4] | OutCap        | R  | 0x0   | Pin complex is not output capable.            |
| [3] | HPhnDrvCap    | R  | 0x0   | Pin does not have a headphone amplifier.      |
| [2] | PresDtctCap   | R  | 0x0   | Pin complex cannot perform Presence Detect.   |
| [1] | TrigRqd       | R  | 0x0   | N/A   |
| [0] | ImpSenseCap   | R  | 0x0   | Pin complex does not support impedance sense. |

### 5.20.3. CDPin Ctl

Table 258. CDPin Ctl Command Verb Format

|             | Verb ID | Payload                          | Response           |
|-------------|---------|----------------------------------|--------------------|
| <b>Get</b>  | F07     | 00                               | See bitfield table |
| <b>Set1</b> | 707     | See bits [7:0] of bitfield table | 0000_0000h         |

Table 259. CDPin Ctl Command Response Format

| Bit    | Bitfield Name | RW | Reset | Description  |
|--------|---------------|----|-------|--|
| [31:6] | Rsvd2         | R  | 0x0   | Reserved   |
| [5]    | InEn          | RW | 0x1   | 1 = (CODEC) input path of Pin Widget is enabled (un-muted) |
| [4:0]  | Rsvd1         | R  | 0x0   | Reserved   |

### 5.20.4. CDPin Config

Table 260. CDPin Config Command Verb Format

|             | Verb ID | Payload                          | Response           |
|-------------|---------|----------------------------------|--------------------|
| <b>Get</b>  | F1C     | 00                               | See bitfield table |
| <b>Set1</b> | 71C     | See bits [7:0] of bitfield table | 0000_0000h         |



Table 260. CDPin Config Command Verb Format

|             | Verb ID | Payload                            | Response   |
|-------------|---------|------------------------------------|------------|
| <b>Set2</b> | 71D     | See bits [15:8] of bitfield table  | 0000_0000h |
| <b>Set3</b> | 71E     | See bits [23:16] of bitfield table | 0000_0000h |
| <b>Set4</b> | 71F     | See bits [31:24] of bitfield table | 0000_0000h |

Table 261. CDPin Config Command Response Format

| Bit     | Bitfield Name | RW | Reset | Description   |
|---------|---------------|----|-------|---|
| [31:30] | Port          | RW | 0x2   | External Port Connectivity of the Pin Complex.<br>2 = fixed function device   |
| [29:24] | Location      | RW | 0x10  | Physical location of the jack. 10h = Internal, N/A  |
| [23:20] | Device        | RW | 0x3   | Default Device, indicating intended use of jack.<br>3 = CD  |
| [19:16] | Connection    | RW | 0x3   | Connection Type. 3 = ATAPI internal   |
| [15:12] | Color         | RW | 0x0   | Color of physical jack. 0 = Unknown   |
| [11:8]  | Misc          | RW | 0x1   | Misc[0] = Jack Detect override.   |
| [7:4]   | Assoc         | RW | 0x2   | Default Association for Pin Complex groups.<br>Reserved value 0000b should not be used.<br>Value 1111b indicates lowest priority. |
| [3:0]   | Sequence      | RW | 0x2   | All Widgets in an association must have unique<br>sequence number.  |

## 5.21. MonoOutMix Node (NID = 0x12)

### 5.21.1. MonoOutMix WCap

Table 262. MonoOutMix WCap Command Verb Format

|            | Verb ID | Payload | Response           |
|------------|---------|---------|--------------------|
| <b>Get</b> | F00     | 09      | See bitfield table |

Table 263. MonoOutMix WCap Command Response Format

| Bit     | Bitfield Name | RW | Reset | Description  |
|---------|---------------|----|-------|--|
| [31:24] | Rsvd2         | R  | 0x0   | Reserved   |
| [23:20] | Type          | R  | 0x2   | Widget type = Audio Mixer  |
| [19:16] | Delay         | R  | 0x0   | Number of sample delays through widget   |
| [15:12] | Rsvd1         | R  | 0x0   | Reserved   |
| [11]    | SwapCap       | R  | 0x0   | Swapping of left and right channels not supported                                    |
| [10]    | PwrCntrl      | R  | 0x0   | No support for Power State control   |
| [9]     | DigitalStrm   | R  | 0x0   | Widget supports an Analog stream   |
| [8]     | ConnList      | R  | 0x1   | Connection list is present   |
| [7]     | UnsolCap      | R  | 0x0   | No support for Unsolicited Response  |
| [6]     | ProcWidget    | R  | 0x0   | No Processing Controls parameter.  |
| [5]     | Stripe        | R  | 0x0   | No support for striping  |
| [4]     | FormatOvrd    | R  | 0x0   | No format info; use default format parameters from Audio Function node instead       |
| [3]     | AmpParamOvrd  | R  | 0x0   | No amplifier info; use default amplifier parameters from Audio Function node instead |
| [2]     | OutAmpPrsnt   | R  | 0x0   | No output amp  |
| [1]     | InAmpPrsnt    | R  | 0x0   | No input amp   |
| [0]     | Stereo        | R  | 0x0   | Mono widget  |

### 5.21.2. MonoOutMix ConnLen

Table 264. MonoOutMix ConnLen Command Verb Format

|     | Verb ID | Payload | Response           |
|-----|---------|---------|--------------------|
| Get | F00     | 0E      | See bitfield table |

Table 265. MonoOutMix ConnLen Command Response Format

| Bit    | Bitfield Name | RW | Reset | Description  |
|--------|---------------|----|-------|--|
| [31:8] | Rsvd          | R  | 0x0   | Reserved.  |
| [7]    | LongForm      | R  | 0x0   | Connection list uses short-form (7-bit) NID entries. |
| [6:0]  | N             | R  | 0x01  | Number of NID entries in connection list.            |

### 5.21.3. MonoOutMix ConnLst

Table 266. MonoOutMix ConnLst Command Verb Format

|     | Verb ID | Payload | Response           |
|-----|---------|---------|--------------------|
| Get | F02     | 00      | See bitfield table |

Table 267. MonoOutMix ConnLst Command Response Format

| Bit     | Bitfield Name | RW | Reset | Description        |
|---------|---------------|----|-------|--------------------|
| [31:24] | Entry3        | R  | 0x00  | Unused list entry. |
| [23:16] | Entry2        | R  | 0x00  | Unused list entry. |
| [15:8]  | Entry1        | R  | 0x00  | Unused list entry. |
| [7:0]   | Entry0        | R  | 0x06  | DAC Mux widget.    |

## 5.22. PCBeep Node (NID = 0x13)

### 5.22.1. PCBeep Vol

Table 268. PCBeep Vol Command Verb Format

|      | Verb ID | Payload                          | Response           |
|------|---------|----------------------------------|--------------------|
| Get  | BA0     | 00                               | See bitfield table |
| Set1 | 3A0     | See bits [7:0] of bitfield table | 0000_0000h         |

Table 269. PCBeep Vol Command Response Format

| Bit    | Bitfield Name | RW | Reset | Description                            |
|--------|---------------|----|-------|--|
| [31:8] | Rsvd2         | R  | 0x0   | Reserved                               |
| [7]    | Mute          | RW | 0x1   | 1 = mute is active                     |
| [6:2]  | Rsvd1         | R  | 0x0   | Reserved                               |
| [1:0]  | Gain          | RW | 0x3   | Mono (left) amplifier gain step number |

### 5.22.2. PCBeep WCap

Table 270. PCBeep WCap Command Verb Format

|            | Verb ID | Payload | Response           |
|------------|---------|---------|--------------------|
| <b>Get</b> | F00     | 09      | See bitfield table |

Table 271. PCBeep WCap Command Response Format

| Bit     | Bitfield Name | RW | Reset | Description  |
|---------|---------------|----|-------|--|
| [31:24] | Rsvd3         | R  | 0x0   | Reserved   |
| [23:20] | Type          | R  | 0x7   | Widget type = Beep Generator                       |
| [19:4]  | Rsvd2         | R  | 0x0   | Reserved   |
| [3]     | AmpParamOvrd  | R  | 0x1   | This widget contains its own amplifier parameters. |
| [2]     | OutAmpPrsnt   | R  | 0x1   | Output amp is present                              |
| [1]     | InAmpPrsnt    | R  | 0x0   | N/A  |
| [0]     | Stereo        | R  | 0x0   | Mono widget  |

### 5.22.3. PCBeep OutAmpCap

Table 272. PCBeep OutAmpCap Command Verb Format

|            | Verb ID | Payload | Response           |
|------------|---------|---------|--------------------|
| <b>Get</b> | F00     | 12      | See bitfield table |

Table 273. PCBeep OutAmpCap Command Response Format

| Bit     | Bitfield Name | RW | Reset | Description   |
|---------|---------------|----|-------|---|
| [31]    | Mute          | R  | 0x1   | Amplifier is capable of muting                                    |
| [30:23] | Rsvd3         | R  | 0x0   | Reserved  |
| [22:16] | StepSize      | R  | 0x17  | Size of each step in the gain range = 6 dB                        |
| [15]    | Rsvd2         | R  | 0x0   | Reserved  |
| [14:8]  | NumSteps      | R  | 0x03  | Number of steps in the gain range = 3<br>(4 values, -18dB to 0dB) |
| [7]     | Rsvd1         | R  | 0x0   | Reserved  |
| [6:0]   | Offset        | R  | 0x03  | 0dB-step is programmed with this offset                           |

### 5.22.4. PCBeep Gen

Table 274. PCBeep Gen Command Verb Format

|             | Verb ID | Payload                          | Response           |
|-------------|---------|----------------------------------|--------------------|
| <b>Get</b>  | F0A     | 00                               | See bitfield table |
| <b>Set1</b> | 70A     | See bits [7:0] of bitfield table | 0000_0000h         |

Table 275. PCBeep Gen Command Response Format

| Bit    | Bitfield Name | RW | Reset | Description   |
|--------|---------------|----|-------|---|
| [31:8] | Rsvd          | R  | 0x0   | Reserved  |
| [7:0]  | Divider       | RW | 0x00  | Enable internal PC-Beep generation.<br>Divider = 00h - disables internal PC Beep generation and enables normal operation of the CODEC.<br>Divider not 00h - generates the beep tone on all Pin Complexes that are currently configured as outputs. The HD Audio spec states that the beep tone: frequency = (48 KHz HD Audio SYNC rate) / (4*Divider), producing tones from 47 Hz to 12 KHz (logarithmic scale). Instead, this part generates tones with frequency = 48000 * (257 - Divider) / 1024, yielding a linear range from 12 KHz to 93.75 Hz in steps of 46.875 Hz. If JackSenseVSR[Rate2x], then the beep tones generated have: frequency = 48000 * (513 - Divider) / 1024, yielding a range of 24 KHz to 12093.75 Hz in steps of 46.875 Hz. |

## 5.23. ADC0InMux Node (NID = 0x14)

### 5.23.1. ADC0InMux WCap

Table 276. ADC0InMux WCap Command Verb Format

|     | Verb ID | Payload | Response           |
|-----|---------|---------|--------------------|
| Get | F00     | 09      | See bitfield table |

Table 277. ADC0InMux WCap Command Response Format

| Bit     | Bitfield Name | RW | Reset | Description                            |
|---------|---------------|----|-------|--|
| [31:24] | Rsvd2         | R  | 0x0   | Reserved                               |
| [23:20] | Type          | R  | 0x3   | Widget type = Audio Selector           |
| [19:16] | Delay         | R  | 0x0   | Number of sample delays through widget |
| [15:12] | Rsvd1         | R  | 0x0   | Reserved                               |
| [11]    | SwapCap       | R  | 0x1   | Left and right channels can be swapped |

Table 277. ADC0InMux WCap Command Response Format

| Bit  | Bitfield Name | RW | Reset | Description  |
|------|---------------|----|-------|--|
| [10] | PwrCntrl      | R  | 0x0   | No support for Power State control   |
| [9]  | DigitalStrm   | R  | 0x0   | Widget supports an Analog stream   |
| [8]  | ConnList      | R  | 0x1   | Connection list is present   |
| [7]  | UnsolCap      | R  | 0x0   | No support for Unsolicited Response  |
| [6]  | ProcWidget    | R  | 0x0   | No Processing Controls parameter.  |
| [5]  | Stripe        | R  | 0x0   | No support for striping  |
| [4]  | FormatOvrd    | R  | 0x0   | No format info; use default format parameters from Audio Function node instead |
| [3]  | AmpParamOvrd  | R  | 0x1   | This widget contains its own amplifier parameters.                             |
| [2]  | OutAmpPrsnt   | R  | 0x1   | Output amp is present  |
| [1]  | InAmpPrsnt    | R  | 0x0   | No input amp   |
| [0]  | Stereo        | R  | 0x1   | Stereo widget  |

### 5.23.2. ADC0InMux ConnLen

Table 278. ADC0InMux ConnLen Command Verb Format

|            | Verb ID | Payload | Response           |
|------------|---------|---------|--------------------|
| <b>Get</b> | F00     | 0E      | See bitfield table |

Table 279. ADC0InMux ConnLen Command Response Format

| Bit    | Bitfield Name | RW | Reset | Description  |
|--------|---------------|----|-------|--|
| [31:8] | Rsvd          | R  | 0x0   | Reserved   |
| [7]    | LongForm      | R  | 0x0   | Connection list uses short-form (7-bit) NID entries.   |
| [6:0]  | N             | R  | 0x02  | Number of NID entries in connection list.<br>2h if Dig Mic is available,<br>1h if it is disabled by bond option. |

### 5.23.3. ADC0InMux ConnSel

Table 280. ADC0InMux ConnSel Command Verb Format

|             | Verb ID | Payload                          | Response           |
|-------------|---------|----------------------------------|--------------------|
| <b>Get</b>  | F01     | 00                               | See bitfield table |
| <b>Set1</b> | 701     | See bits [7:0] of bitfield table | 0000_0000h         |

Table 281. ADC0InMux ConnSel Command Response Format

| Bit    | Bitfield Name | RW | Reset | Description                      |
|--------|---------------|----|-------|----------------------------------|
| [31:2] | Rsvd          | R  | 0x0   | Reserved                         |
| [1:0]  | Index         | RW | 0x0   | Connection select control index. |

### 5.23.4. ADC0InMux ConnLst

Table 282. ADC0InMux ConnLst Command Verb Format

|            | Verb ID | Payload | Response           |
|------------|---------|---------|--------------------|
| <b>Get</b> | F02     | 00      | See bitfield table |

Table 283. ADC0InMux ConnLst Command Response Format

| Bit     | Bitfield Name | RW | Reset | Description  |
|---------|---------------|----|-------|--|
| [31:24] | Entry3        | R  | 0x00  | Unused list entry  |
| [23:16] | Entry2        | R  | 0x00  | Unused list entry  |
| [15:8]  | Entry1        | R  | 0x15  | Dig Mic pin widget (15h) if Dig Mic is available, 0h if it is disabled by bond option. |
| [7:0]   | Entry0        | R  | 0x09  | ADC0VolMux   |



5.23.5. *ADC0InMux LR*

Table 284. ADC0InMux LR Command Verb Format

|             | Verb ID | Payload                          | Response           |
|-------------|---------|----------------------------------|--------------------|
| <b>Get</b>  | F0C     | 00                               | See bitfield table |
| <b>Set1</b> | 70C     | See bits [7:0] of bitfield table | 0000_0000h         |

Table 285. ADC0InMux LR Command Response Format

| Bit    | Bitfield Name | RW | Reset | Description                                      |
|--------|---------------|----|-------|--|
| [31:3] | Rsvd2         | R  | 0x0   | Reserved   |
| [2]    | SwapEn        | RW | 0x0   | 1 = swap left and right channels of this Widget. |
| [1:0]  | Rsvd1         | R  | 0x0   | Reserved   |

5.23.6. *ADC0InMux OutAmpCap*

Table 286. ADC0InMux OutAmpCap Command Verb Format

|            | Verb ID | Payload | Response           |
|------------|---------|---------|--------------------|
| <b>Get</b> | F00     | 12      | See bitfield table |

Table 287. ADC0InMux OutAmpCap Command Response Format

| Bit     | Bitfield Name | RW | Reset | Description   |
|---------|---------------|----|-------|---|
| [31]    | Mute          | R  | 0x1   | Amplifier is capable of muting                                    |
| [30:23] | Rsvd3         | R  | 0x0   | Reserved  |
| [22:16] | StepSize      | R  | 0x00  | Size of each step in the gain range, N/A since there are no steps |
| [15]    | Rsvd2         | R  | 0x0   | Reserved  |
| [14:8]  | NumSteps      | R  | 0x00  | No steps, gain is fixed at 0dB                                    |
| [7]     | Rsvd1         | R  | 0x0   | Reserved  |
| [6:0]   | Offset        | R  | 0x00  | 0dB-step is programmed with this offset                           |

### 5.23.7. ADC0InMux VolRight

Table 288. ADC0InMux VolRight Command Verb Format

|             | Verb ID | Payload                          | Response           |
|-------------|---------|----------------------------------|--------------------|
| <b>Get</b>  | B80     | 00                               | See bitfield table |
| <b>Set1</b> | 390     | See bits [7:0] of bitfield table | 0000_0000h         |

Table 289. ADC0InMux VolRight Command Response Format

| Bit    | Bitfield Name | RW | Reset | Description        |
|--------|---------------|----|-------|--------------------|
| [31:8] | Rsvd2         | R  | 0x0   | Reserved           |
| [7]    | Mute          | RW | 0x1   | 1 = mute is active |
| [6:0]  | Rsvd1         | R  | 0x0   | Reserved           |

### 5.23.8. ADC0InMux VolLeft

Table 290. ADC0InMux VolLeft Command Verb Format

|             | Verb ID | Payload                          | Response           |
|-------------|---------|----------------------------------|--------------------|
| <b>Get</b>  | BA0     | 00                               | See bitfield table |
| <b>Set1</b> | 3A0     | See bits [7:0] of bitfield table | 0000_0000h         |

Table 291. ADC0InMux VolLeft Command Response Format

| Bit    | Bitfield Name | RW | Reset | Description        |
|--------|---------------|----|-------|--------------------|
| [31:8] | Rsvd2         | R  | 0x0   | Reserved           |
| [7]    | Mute          | RW | 0x1   | 1 = mute is active |
| [6:0]  | Rsvd1         | R  | 0x0   | Reserved           |

## 5.24. DigMicPin Node (NID = 0x15)

### 5.24.1. DigMicPin WCap

Table 292. DigMicPin WCap Command Verb Format

|     | Verb ID | Payload | Response           |
|-----|---------|---------|--------------------|
| Get | F00     | 09      | See bitfield table |

Table 293. DigMicPin WCap Command Response Format

| Bit     | Bitfield Name | RW | Reset | Description   |
|---------|---------------|----|-------|---|
| [31:24] | Rsvd2         | R  | 0x0   | Reserved  |
| [23:20] | Type          | R  | 0x4   | Widget type = Pin Complex   |
| [19:16] | Delay         | R  | 0x0   | Number of sample delays through widget  |
| [15:12] | Rsvd1         | R  | 0x0   | Reserved  |
| [11]    | SwapCap       | R  | 0x0   | No left/right channel swap capability   |
| [10]    | PwrCntrl      | R  | 0x0   | No support for Power State control  |
| [9]     | DigitalStrm   | R  | 0x0   | Widget supports an Analog stream (Since the digital microphone input is a SDM signal that needs to be processed by the digital filters, it is not a true bit for bit digital stream like I <sup>2</sup> S or SPDIF where samples are passed through unchanged.) |
| [8]     | ConnList      | R  | 0x0   | No connection list is present   |
| [7]     | UnsolCap      | R  | 0x0   | No support for Unsolicited Response   |
| [6]     | ProcWidget    | R  | 0x0   | No Processing Controls parameter  |
| [5]     | Stripe        | R  | 0x0   | No support for striping   |
| [4]     | FormatOvrd    | R  | 0x0   | N/A for pin complex   |
| [3]     | AmpParamOvrd  | R  | 0x0   | No amplifier info; use default amplifier parameters from Audio Function node instead.   |
| [2]     | OutAmpPrsnt   | R  | 0x0   | No output amp   |

Table 293. DigMicPin WCap Command Response Format

| Bit | Bitfield Name | RW | Reset | Description   |
|-----|---------------|----|-------|---------------|
| [1] | InAmpPrsnt    | R  | 0x0   | No input amp  |
| [0] | Stereo        | R  | 0x1   | Stereo widget |

### 5.24.2. DigMicPin Cap

Table 294. DigMicPin Cap Command Verb Format

|            | Verb ID | Payload | Response           |
|------------|---------|---------|--------------------|
| <b>Get</b> | F00     | 0C      | See bitfield table |

Table 295. DigMicPin Cap Command Response Format

| Bit     | Bitfield Name | RW | Reset | Description  |
|---------|---------------|----|-------|--|
| [31:17] | Rsvd2         | R  | 0x0   | Reserved   |
| [16]    | EapdCap       | R  | 0x0   | This widget does not control EAPD pin              |
| [15:8]  | VRefCntrl     | R  | 0x00  | VRef generation not supported by this pin complex. |
| [7]     | Rsvd1         | R  | 0x0   | Reserved   |
| [6]     | BalancedIO    | R  | 0x0   | Pin complex does not have balanced pins.           |
| [5]     | InCap         | R  | 0x1   | Pin complex is input capable.                      |
| [4]     | OutCap        | R  | 0x0   | Pin complex is not output capable.                 |
| [3]     | HPhnDrvCap    | R  | 0x0   | Pin does not have a headphone amplifier.           |
| [2]     | PresDtctCap   | R  | 0x0   | Pin complex cannot perform Presence Detect.        |
| [1]     | TrigRqd       | R  | 0x0   | N/A  |
| [0]     | ImpSenseCap   | R  | 0x0   | Pin complex does not support impedance sense.      |

### 5.24.3. DigMicPin Ctl

Table 296. DigMicPin Ctl Command Verb Format

|             | Verb ID | Payload                          | Response           |
|-------------|---------|----------------------------------|--------------------|
| <b>Get</b>  | F07     | 00                               | See bitfield table |
| <b>Set1</b> | 707     | See bits [7:0] of bitfield table | 0000_0000h         |

Table 297. DigMicPin Ctl Command Response Format

| Bit    | Bitfield Name | RW | Reset | Description                                     |
|--------|---------------|----|-------|---|
| [31:6] | Rsvd2         | R  | 0x0   | Reserved  |
| [5]    | InEn          | RW | 0x0   | 1 = (CODEC) input path of Pin Widget is enabled |
| [4:0]  | Rsvd1         | R  | 0x0   | Reserved  |

### 5.24.4. DigMicPin Config

Table 298. DigMicPin Config Command Verb Format

|             | Verb ID | Payload                            | Response           |
|-------------|---------|------------------------------------|--------------------|
| <b>Get</b>  | F1C     | 00                                 | See bitfield table |
| <b>Set1</b> | 71C     | See bits [7:0] of bitfield table   | 0000_0000h         |
| <b>Set2</b> | 71D     | See bits [15:8] of bitfield table  | 0000_0000h         |
| <b>Set3</b> | 71E     | See bits [23:16] of bitfield table | 0000_0000h         |
| <b>Set4</b> | 71F     | See bits [31:24] of bitfield table | 0000_0000h         |

Table 299. DigMicPin Config Command Response Format

| Bit     | Bitfield Name | RW | Reset | Description  |
|---------|---------------|----|-------|--|
| [31:30] | Port          | RW | 0x1   | External Port Connectivity of the Pin Complex.<br>1 = no physical connection |
| [29:24] | Location      | RW | 0x10  | Physical location of the jack. 10h = Internal, N/A                           |
| [23:20] | Device        | RW | 0xA   | Default Device, indicating intended use of jack.<br>A = Mic In               |

Table 299. DigMicPin Config Command Response Format

| Bit     | Bitfield Name | RW | Reset | Description   |
|---------|---------------|----|-------|---|
| [19:16] | Connection    | RW | 0x0   | Connection Type. 0 = Unknown  |
| [15:12] | Color         | RW | 0x0   | Color of physical jack. 0 = Unknown   |
| [11:8]  | Misc          | RW | 0x1   | Misc[0] = Jack Detect override.   |
| [7:4]   | Assoc         | RW | 0xF   | Default Association for Pin Complex groups. Reserved value 0000b should not be used. Value 1111b indicates lowest priority. |
| [3:0]   | Sequence      | RW | 0x1   | All Widgets in an association must have unique sequence number.   |

## 6. ORDERING INFORMATION

### 6.1. STAC9202 Options and Part Numbers

The +4 V Analog voltage is supported by the +5 V version of the STAC9202 or STAC9202D.

\*Dolby requires the 5 V version of this part except for Dolby Digital Live (DDL).

| Part Order Number | Voltage   | DAC SNR | Dolby*    | Pkg Pins |
|-------------------|-----------|---------|-----------|----------|
| STAC9202D5TAEyy   | 5 V / 4 V | 100dB   | Yes       | 48 LQFP  |
| STAC9202X5TAEyy   | 5 V / 4 V | 100dB   | No        | 48 LQFP  |
| STAC9202D3TAEyy   | 3.3 V     | 100dB   | Yes (DDL) | 48 LQFP  |
| STAC9202X3TAEyy   | 3.3 V     | 100dB   | No        | 48 LQFP  |

NOTE: When ordering these parts the “yy” will be replaced with the CODEC revision. Add an “R” to the end of any of these part numbers for delivery on Tape and Reel. The minimum order quantity for Tape and Reel is 2,000 units for both package options.

## 7. PIN INFORMATION

### 7.1. STAC9202 Pin Diagram

Figure 3. STAC9202 Pin Diagram

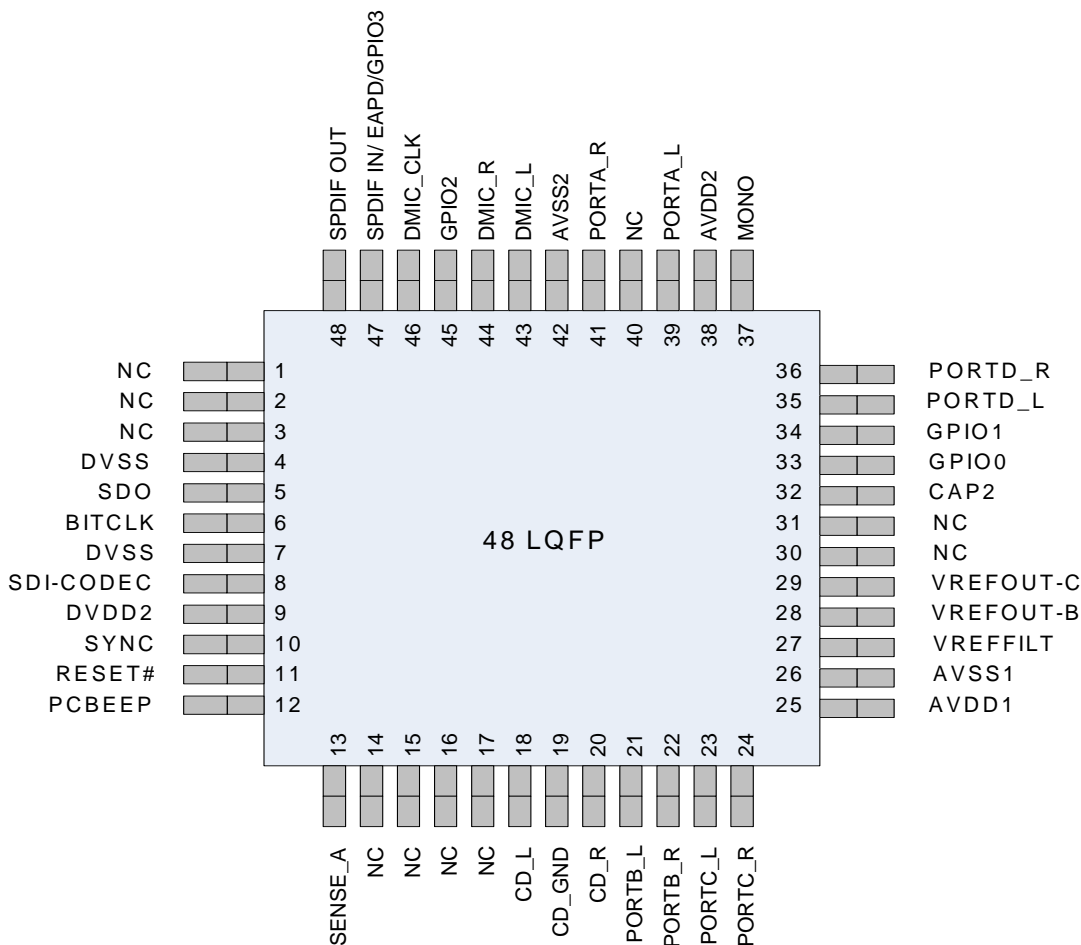

### 7.2. Pin Table for STAC9202

| Pin Name  | Pin Function                                 | I/O          | Internal Pull-up /Pull-down | Pin Location |
|-----------|--|--------------|-----------------------------|--------------|
| NC        | No Connect                                   | None         | None                        | 1            |
| NC        | No Connect                                   | None         | None                        | 2            |
| NC        | No Connect                                   | None         | None                        | 3            |
| DVSS      | Digital Ground                               | I(Digital)   | None                        | 4            |
| SDATA_OUT | HD Audio Serial Data output (inbound stream) | I/O(Digital) | None                        | 5            |
| BIT_CLK   | HD Audio Bit Clock                           | I(Digital)   | None                        | 6            |



| Pin Name        | Pin Function   | I/O          | Internal Pull-up /Pull-down      | Pin Location |
|-----------------|--|--------------|----------------------------------|--------------|
| DVSS            | Digital Ground   | I(Digital)   | None                             | 7            |
| SDATA_IN/ CODEC | HD Audio Serial Data input for the CODEC (outbound stream)               | O(Digital)   | None                             | 8            |
| DVDD_CORE2      | Digital Vdd = 3.3 V  | I(Digital)   | None                             | 9            |
| SYNC            | HD Audio Frame Sync  | I(Digital)   | None                             | 10           |
| RESET#          | HD Audio Reset   | I(Digital)   | None                             | 11           |
| PCBEEP          | PC Beep  | I(Analog)    | None                             | 12           |
| SENSE_A         | Jack insertion detection Ports A, B, C, D                                | I(Analog)    | None                             | 13           |
| NC              | No Connect   | None         | None                             | 14           |
| NC              | No Connect   | None         | None                             | 15           |
| NC              | No Connect   | None         | None                             | 16           |
| NC              | No Connect   | None         | None                             | 17           |
| CD-L            | CD Audio Left Channel  | I(Analog)    | None                             | 18           |
| CD-GND          | CD Audio Analog Ground   | I(Analog)    | None                             | 19           |
| CD-R            | CD Audio Right Channel   | I(Analog)    | None                             | 20           |
| PORT-B_L        | Input/Output of Left DAC0  | I/O(Analog)  | None                             | 21           |
| PORT-B_R        | Input/Output of Right DAC0   | I/O(Analog)  | None                             | 22           |
| PORT-C_L        | Input/Output of Left DAC0  | I/O(Analog)  | None                             | 23           |
| PORT-C_R        | Input/Output of Right DAC0   | I/O(Analog)  | None                             | 24           |
| AVDD1           | Analog Vdd = 5.0 V or 3.3 V  | I(Analog)    | None                             | 25           |
| AVSS1           | Analog Ground  | I(Analog)    | None                             | 26           |
| VREF FILT       | Analog Virtual Ground  | O(Analog)    | None                             | 27           |
| VREFOUT-B       | Reference Voltage out drive<br>(intended for microphone bias) for Port B | O(Analog)    | None                             | 28           |
| VREFOUT-C       | Reference Voltage out drive<br>(intended for microphone bias) for Port C | O(Analog)    | None                             | 29           |
| NC              | No Connect   | None         | None                             | 30           |
| NC              | No Connect   | None         | None                             | 31           |
| CAP2            | ADC reference Cap  | O(Analog)    | None                             | 32           |
| GPIO0           | General Purpose I/O tied to AVDD50K internal<br>pull-up to AVddgnda      | I/O(Digital) | Pull-up 50 K $\Omega$<br>or more | 33           |
| GPIO1           | General Purpose I/O tied to AVDD50K internal<br>pull-up to AVddgnda      | I/O(Digital) | Pull-up 50 K $\Omega$<br>or more | 34           |
| PORT-D_L        | Input/Output of Left DAC0  | I/O(Analog)  | None                             | 35           |
| PORT-D_R        | Input/Output of Right DAC0   | I/O(Analog)  | None                             | 36           |
| MONO            | Mono Out from DAC  | O(Analog)    | None                             | 37           |
| AVDD2           | Analog Vdd = 5.0 V or 3.3 V  | I(Analog)    | None                             | 38           |
| PORT-A_L        | Input/Output of Left DAC0  | I/O(Analog)  | None                             | 39           |

| Pin Name           | Pin Function  | I/O          | Internal Pull-up /Pull-down         | Pin Location |
|--------------------|---|--------------|-------------------------------------|--------------|
| NC                 | No Connect  | None         | None                                | 40           |
| PORT-A_R           | Input/Output of Right DAC0  | I/O(Analog)  | None                                | 41           |
| AVSS3              | Analog Ground   | I(Analog)    | None                                | 42           |
| DMIC_L             | Digital Mic Input Left Channel                                      | I(Digital)   | None                                | 43           |
| DMIC_R             | Digital Mic Input Right Channel                                     | I(Digital)   | None                                | 44           |
| GPIO2              | General Purpose I/O tied to AVDD50K<br>internal pull-up to AVddgnda | I/O(Digital) | Pull-up 50 K $\Omega$<br>or more    | 45           |
| DMIC_CLK           | Digital Mic Output Clock  | O(Digital)   | None                                | 46           |
| SPDIFIN/EAPD/GPIO3 | SPDIF Input, External Amplifier Power Down, General Purpose I/O     | I/O(Digital) | None                                | 47           |
| S/SPDIF_OUT        | SPDIF digital output (50K internal pull-down)                       | O(Digital)   | 50 K $\Omega$ internal<br>pull-down | 48           |

## 8. PACKAGE DRAWINGS

### 8.1. 48-Pin LQFP

Figure 4. 48-Pin LQFP Package Outline and Package Dimensions

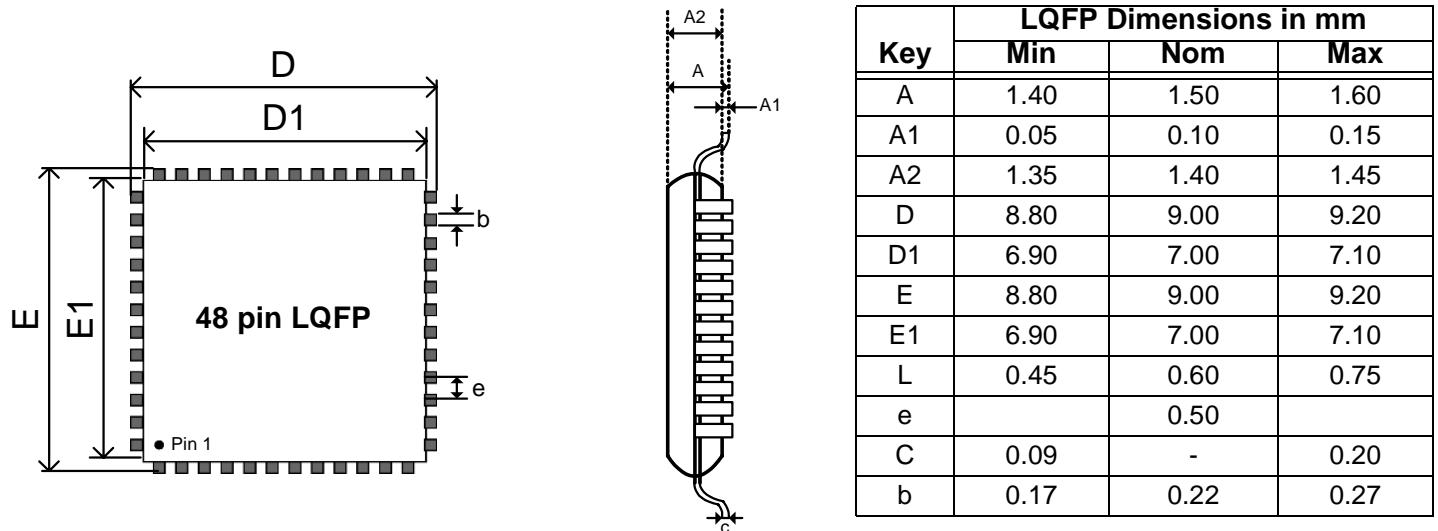

## 9. SOLDER REFLOW PROFILE

### 9.1. Standard Reflow Profile Data

Note: These devices can be hand soldered at 360 °C for 3 to 5 seconds.

**FROM:** IPC / JEDEC J-STD-020C "Moisture/Reflow Sensitivity Classification for Nonhermetic Solid State Surface Mount Devices" ([www.jedec.org/download](http://www.jedec.org/download)).

| Profile Feature   | Pb Free Assembly  |
|---|---|
| Average Ramp-Up Rate ( $T_{S_{max}} - T_p$ )  | 3 °C / second max   |
| Preheat<br>Temperature Min ( $T_{S_{min}}$ )<br>Temperature Max ( $T_{S_{max}}$ )<br>Time ( $t_{S_{min}} - t_{S_{max}}$ ) | 150 °C<br>200 °C<br>60 - 180 seconds                          |
| Time maintained above<br>Temperature ( $T_L$ )<br>Time ( $t_L$ )  | 217 °C<br>60 - 150 seconds                                    |
| Peak / Classification Temperature ( $T_p$ )   | See "Package Classification Reflow Temperatures" on page 133. |
| Time within 5 °C of actual Peak Temperature ( $t_p$ )   | 20 - 40 seconds   |
| Ramp-Down rate  | 6 °C / second max   |
| Time 25 °C to Peak Temperature  | 8 minutes max   |
| <b>Note: All temperatures refer to topside of the package, measured on the package body surface.</b>                      |   |

Figure 5. Solder Reflow Profile

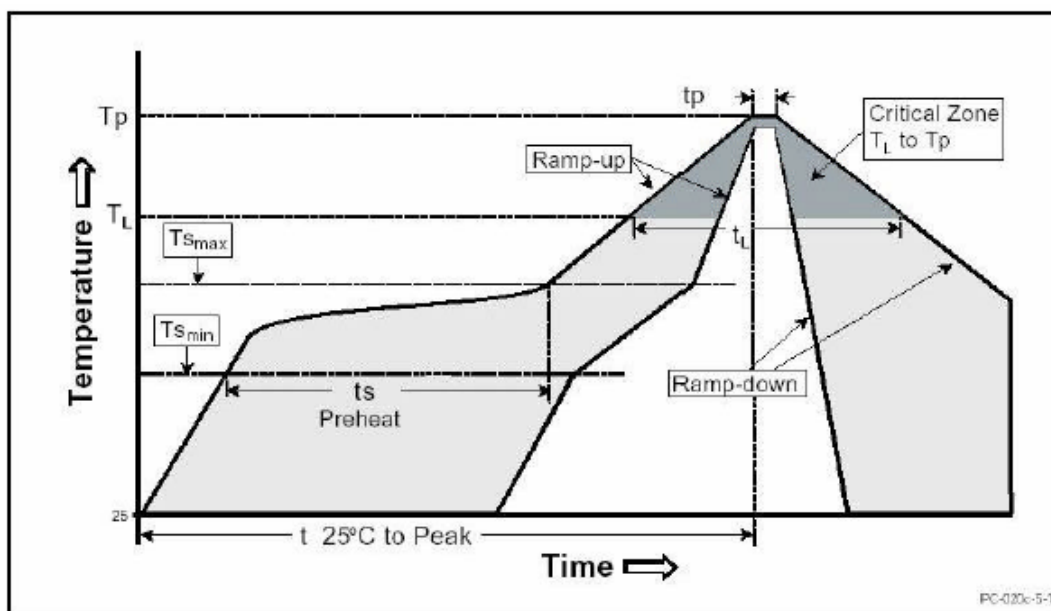

## 9.2. Pb Free Process - Package Classification Reflow Temperatures

| Package Type | MSL | Reflow Temperature |
|--------------|-----|--------------------|
| LQFP 48-pin  | 3   | 260 °C*            |

## 10. REVISION HISTORY

| Revision | Date            | Description of Change  |
|----------|-----------------|--|
| 0.1      | May 2005        | Initial Release  |
| 0.5      | August 2005     | Updated 5 V Analog Performance Characteristics numbers. Updated 48 Pin Reflow Profile Table. This is a visual change only. No content was changed.                   |
| 0.8      | September 2005  | Updated Power Consumption numbers. Added in Contact IDT note for 4 V and 3.3 V Analog AC numbers. Added updated note 4 on AC table. Added note 2 for 40dB mic boost. |
| 1.0      | November 2006   | Updated logo   |
| 1.1      | 26 October 2006 | Released in IDT format.  |

**Innovate with IDT audio for high fidelity. Contact:**

[www.IDT.com](http://www.IDT.com)

**For Sales**

800-345-7015  
408-284-8200  
Fax: 408-284-2775

**For Tech Support**

[HA.CM@idt.com](mailto:HA.CM@idt.com)

---

**Corporate Headquarters**

Integrated Device Technology, Inc.  
6024 Silver Creek Valley Road  
San Jose, CA 95138  
United States  
800 345 7015  
+408 284 8200 (outside U.S.)

**Europe**

IDT Europe, Limited  
Prime House  
Barnett Wood Lane  
Leatherhead, Surrey  
United Kingdom KT22 7DE  
+44 1372 363 339

