



# **W83627DHG**

## **WINBOND LPC I/O**

Note: This document is for UBC, UBE and UBF version except specified descriptions

Date : April 10, 2007    Version : 1.4





## Data Sheet Revision History

	PAGES	DATES	VERSION	WEB VERSION	MAIN CONTENTS
1	N.A.	12/15/2005	0.1	N.A.	1. First published version.
2	N.A.	02/22/2006	0.2	N.A.	1. Add descriptions of the registers, functions,, AC/DC timing, and top marking
3	N.A.	03/15/2006	0.3	N.A.	<ol style="list-style-type: none"> <li>1. Revise Table 8.1 and the timing chart of section 10.3.1</li> <li>2. Add registers for AMDSI at LDB, CRF5h,CRF6h and F7h(Bank1)</li> <li>3. Swap LDB, CRF2h bit 0 and bit 1.</li> <li>4. Modify the default values for LDA, CRFEh</li> <li>5. Modify the descriptions of LD9, CR30h bit 0 and CRF7h bit 4.</li> <li>6. Remove LDA, CRE9h bit4 ~ 3</li> <li>7. Swap LDC, CRE0h bit3~0 and CRE5h bit7~4</li> </ol>
4	N.A.	05/05/2006	0.4	N.A.	<ol style="list-style-type: none"> <li>1. Add FDC, UART, Parallel Port and KBC interface descriptions</li> <li>2. Remove all the descriptions about AMDSI</li> <li>3. Modify the diagrams and descriptions for Current Mode</li> <li>4. Add two control bits for the selections of SYSFANOUT and CPUFANOUT0 output type at CR[24h]</li> <li>5. Remove the description of the internal pulled-up resistor of Parallel Port</li> <li>6. Modify the definitions of edge/level and enable/disable debounce circuit of GP30, GP31 and GP35</li> <li>7. Modify the descriptions of LD7, CRF7h and LD9, CRE6h ~ CRE9h</li> <li>8. Correct typos and grammatical mistakes</li> </ol>
5	N.A.	05/15/2006	0.41	N.A.	1. Remove the remaining descriptions about AMDSI in datasheet ver.0.4
6	N.A.	05/19/2006	0.42	N.A.	<ol style="list-style-type: none"> <li>1. Add a note for Index# of FDC Interface and pin 83(GP42) of Serial Port &amp; Infrared Port Interface in Pin Description</li> <li>2. Reserve the bit 7 of LD0, CRF0h</li> <li>3. Modify the descriptions of TRAK0#, WP#, RDATA# and DSKCHG# of FDC Interface</li> <li>4. Modify the descriptions for strapping pins: HEFRAS, PENROM, PENKBC and EN_GTL</li> <li>5. Modify the DC spec.</li> </ol>
7	N.A.	06/23/2006	0.5	N.A.	<ol style="list-style-type: none"> <li>1. Remove the note and renew the descriptions for Index# of FDC Interface.</li> <li>2. Correct the descriptions of HM Device Bank 0, CR[12h] bit0.</li> <li>3. Add two control bits for AUXFANOUT and CPUFAOUT1 output type selection.</li> <li>4. Add a new bit at LDC, CR[E8h] bit 1 for more PECL</li> </ol>



	PAGES	DATES	VERSION	WEB VERSION	MAIN CONTENTS
					clock selection. 5. Modify the default values of HM Device Bank 0, CR[43h] bit 5,0 and CR[46h] bit 2~1.
<b>8</b>	N.A.	09/29/2006	0.6	N.A.	<ol style="list-style-type: none"> <li>1. Add new chapters for Serial Peripheral Interface, Configuration Register Access Protocol, Power Management, Serialized IRQ, Watchdog Timer VID Inputs and Outputs, and PCI Reset Buffers.</li> <li>2. Update the feature lists of the W83627DHG in Chapter 2 Features.</li> <li>3. Add descriptions of PECl and SST and a table of SMBus in Chapter 5 Pin Description.</li> <li>4. Add new sections of Caseopen and Beep Alarm Function in Chapter 7 Hardware Monitor.</li> <li>5. Add Clock Input Timing, PECl &amp; SST Timing, and SPI Timing in Chapter 21 Specifications.</li> <li>6. Remove sections 9.4 and 9.5 (EXTFDD and EXT2FDD).</li> <li>7. Modify the descriptions of Hardware Monitor Device, Bank 0, Index 59h, bits(6..4).</li> <li>8. Add a beep control bit for VIN4 at Hardware Monitor Device, Bank 0, Index 57h, bit6.</li> <li>9. Remove status bit of PME# status of MIDI IRQ event at Logical Device A, CRF4, bit 1.</li> <li>10. Remove control bit of enable/disable PME# of MIDI at Logical Device A, CRF7, bit 1.</li> <li>11. Modify the descriptions of Tape Drive Register in Chapter 10 Floppy Disk Controller.</li> <li>12. Correct the description of Digital Input Register, bit (6-4) in Chapter 10 Floppy Disk Controller.</li> <li>13. Remove the description of "MR pin" in Digital Output Register in Chapter 10 Floppy Disk Controller.</li> <li>14. Adapt "Serial Flash Interface" to "Serial Peripheral Interface".</li> <li>15. Modify "Absolute Maximum Ratings" in Chapter 21 Specifications.</li> <li>16. Remove "V<sub>DD</sub> is 5V± 10% tolerance" from the description of DC Characteristics in Chapter 21 Specifications.</li> <li>17. Update "S5<sub>cold</sub> state" to "S5 state".</li> <li>18. Remove the section of "AT Interface" in Chapter 10 Floppy Disk Controller.</li> </ol>
<b>9</b>	N.A.	10/05/2006	1.0	N.A.	1. Update AC Timing parameters and waveforms.
<b>10</b>	N.A.	12/12/2006	1.1	N.A.	<ol style="list-style-type: none"> <li>1. Update Table 9.1 and Table 9.2 in Chapter 9 Serial Peripheral Interface</li> <li>2. Update CR2Ah in Chapter 20 Configuration Register</li> <li>3. Modify CR24h bit 0 to reserved</li> </ol>



	PAGES	DATES	VERSION	WEB VERSION	MAIN CONTENTS
					4. Use "Tbase" instead of "TControl" 5. Add the pins, registers description and AC timing for new ACPI function – VSBGATE#, ATXPGD, FTPRST, PWROK2 and SUSC#
11	N.A.	01/25/2007	1.2	N.A.	1. Modify the description for VSBGATE#, ATXPGD, FTPRST. 2. Revise the definition for Logical Device A, CR[E5h] bit 0. 3. Add new section of PWROK Generation in Chapter 14 Power Management Event. 4. Add new timing of VSBGATE# in Chapter 21 Specifications. 5. Modify the description of CR[2Ah], bits [7:4]. 6. Modify the "t1" timing of RSMRST#. 7. Modify the descriptions of 7.7.2 OVT# Interrupt Mode. 8. Modify the "t3" and "t4" timing in Table 14.4 and section 21.3.3
12	N.A.	03/28/2007	1.3	N.A.	1. Add a new DC spec. of RSMRST# PWROK for UBF version (In section 14.3 and 14.4) 2. Add LPC Timing in section 21.4 3. Remove redundant Power on/off and LRESET# Timing
13	N.A.	04/10/2007	1.4	N.A.	1. Modify LPC Timing in section 21.4

Please note that all data and specifications are subject to change without notice. All the trademarks of products and companies mentioned in this data sheet belong to their respective owners.

#### LIFE SUPPORT APPLICATIONS

These products are not designed for use in life support appliances, devices, or systems where malfunction of these products can reasonably be expected to result in personal injury. Winbond customers using or selling these products for use in such applications do so at their own risk and agree to fully indemnify Winbond for any damages resulting from such improper use or sales.



## Table of Contents-

1. GENERAL DESCRIPTION .....	1
2. FEATURES .....	2
3. BLOCK DIAGRAM .....	5
4. PIN LAYOUT .....	6
5. PIN DESCRIPTION .....	8
5.1 LPC Interface .....	9
5.2 FDC Interface .....	9
5.3 Multi-Mode Parallel Port .....	10
5.4 Serial Port & Infrared Port Interface .....	12
5.5 KBC Interface .....	14
5.6 Serial Peripheral Interface .....	14
5.7 Hardware Monitor Interface .....	15
5.8 PECE Interface .....	17
5.9 SST Interface .....	17
5.10 Advanced Configuration and Power Interface .....	17
5.11 General Purpose I/O Port .....	18
5.11.1 SMBus Interface .....	18
5.11.2 GPIO Power Source .....	18
5.11.3 GPIO-2 Interface .....	19
5.11.4 GPIO-3 Interface .....	20
5.11.5 GPIO-4 Interface .....	20
5.11.6 GPIO-5 Interface .....	21
5.11.7 GPIO-6 Interface .....	21
5.11.8 GPIO-4 with WDTO# / SUSLED Multi-function .....	22
5.12 Particular ACPI Function pins – both for UBE and UBF Version Only .....	22
5.13 POWER PINS .....	23
6. CONFIGURATION REGISTER ACCESS PROTOCOL .....	24
6.1 Configuration Sequence .....	25
6.1.1 Enter the Extended Function Mode .....	25
6.1.2 Configure the Configuration Registers .....	25
6.1.3 Exit the Extended Function Mode .....	26
6.1.4 Software Programming Example .....	26
7. HARDWARE MONITOR .....	28
7.1 General Description .....	28
7.2 Access Interfaces .....	28
7.2.1 LPC Interface .....	29
7.2.2 I <sup>2</sup> C interface .....	30
7.3 Analog Inputs .....	31
7.3.1 Voltages Over 2.048 V or Less Than 0 V .....	31
7.3.2 Voltage Detection .....	32



7.3.3	Temperature Sensing.....	32
7.4	SST Command Summary .....	34
7.4.1	Command Summary .....	34
7.4.2	Combination Sensor Data Format.....	35
7.5	PECI .....	36
7.6	Fan Speed Measurement and Control.....	39
7.6.1	Fan Speed Measurement.....	39
7.6.2	Fan Speed Control .....	40
7.6.3	SMART FAN™ Control .....	41
7.7	Interrupt Detection.....	50
7.7.1	SMI# Interrupt Mode .....	50
7.7.2	OVT# Interrupt Mode .....	53
7.7.3	Caseopen Detection.....	54
7.7.4	BEEP Alarm Function .....	55
8.	HARDWARE MONITOR REGISTER SET .....	56
8.1	Address Port (Port x5h).....	56
8.2	Data Port (Port x6h) .....	56
8.3	SYSFANOUT PWM Output Frequency Configuration Register - Index 00h (Bank 0).....	57
8.4	SYSFANOUT Output Value Select Register - Index 01h (Bank 0).....	57
8.5	CPUFANOUT0 PWM Output Frequency Configuration Register - Index 02h (Bank 0) .....	58
8.6	CPUFANOUT0 Output Value Select Register - Index 03h (Bank 0) .....	59
8.7	FAN Configuration Register I - Index 04h (Bank 0) .....	59
8.8	SYSTIN Target Temperature Register/ SYSFANIN Target Speed Register - Index 05h (Bank 0).....	60
8.9	CPUTIN Target Temperature Register/ CPUFANIN0 Target Speed Register - Index 06h (Bank 0).....	61
8.10	Tolerance of Target Temperature or Target Speed Register - Index 07h (Bank 0).....	61
8.11	SYSFANOUT Stop Value Register - Index 08h (Bank 0) .....	62
8.12	CPUFANOUT0 Stop Value Register - Index 09h (Bank 0).....	62
8.13	SYSFANOUT Start-up Value Register - Index 0Ah (Bank 0) .....	63
8.14	CPUFANOUT0 Start-up Value Register - Index 0Bh (Bank 0) .....	63
8.15	SYSFANOUT Stop Time Register - Index 0Ch (Bank 0).....	64
8.16	CPUFANOUT0 Stop Time Register - Index 0Dh (Bank 0) .....	64
8.17	Fan Output Step Down Time Register - Index 0Eh (Bank 0).....	65
8.18	Fan Output Step Up Time Register - Index 0Fh (Bank 0).....	65
8.19	AUXFANOUT PWM Output Frequency Configuration Register - Index 10h (Bank 0) .....	66
8.20	AUXFANOUT Output Value Select Register - Index 11h (Bank 0).....	66
8.21	FAN Configuration Register II - Index 12h (Bank 0) .....	67
8.22	AUXTIN Target Temperature Register/ AUXFANIN0 Target Speed Register - Index 13h (Bank 0).....	68
8.23	Tolerance of Target Temperature or Target Speed Register - Index 14h (Bank 0).....	69
8.24	AUXFANOUT Stop Value Register - Index 15h (Bank 0).....	69
8.25	AUXFANOUT Start-up Value Register - Index 16h (Bank 0).....	70



8.26	AUXFANOUT Stop Time Register - Index 17h (Bank 0) .....	70
8.27	OVT# Configuration Register - Index 18h (Bank 0) .....	71
8.28	Reserved Registers - Index 19h ~ 1Fh (Bank 0) .....	71
8.29	Value RAM — Index 20h ~ 3Fh (Bank 0).....	71
8.30	Configuration Register - Index 40h (Bank 0).....	73
8.31	Interrupt Status Register 1 - Index 41h (Bank 0) .....	73
8.32	Interrupt Status Register 2 - Index 42h (Bank 0) .....	74
8.33	SMI# Mask Register 1 - Index 43h (Bank 0).....	75
8.34	SMI# Mask Register 2 - Index 44h (Bank 0).....	75
8.35	Reserved Register - Index 45h (Bank 0).....	75
8.36	SMI# Mask Register 3 - Index 46h (Bank 0).....	75
8.37	Fan Divisor Register I - Index 47h (Bank 0).....	76
8.38	Serial Bus Address Register - Index 48h (Bank 0) .....	77
8.39	CPUFANOUT0/AUXFANOUT monitor Temperature source select register - Index 49h (Bank 0).....	77
8.40	CPUFANOUT1 Monitor Temperature Source Select Register - Index 4Ah (Bank 0).....	78
8.41	Fan Divisor Register II - Index 4Bh (Bank 0) .....	79
8.42	SMI#/OVT# Control Register - Index 4Ch (Bank 0).....	79
8.43	FAN IN/OUT Control Register - Index 4Dh (Bank 0) .....	80
8.44	Register 50h ~ 5Fh Bank Select Register - Index 4Eh (Bank 0) .....	81
8.45	Winbond Vendor ID Register - Index 4Fh (Bank 0) .....	81
8.46	Reserved Register - Index 50h ~ 55h (Bank 0) .....	82
8.47	BEEP Control Register 1 - Index 56h (Bank 0).....	82
8.48	BEEP Control Register 2 - Index 57h (Bank 0).....	83
8.49	Chip ID - Index 58h (Bank 0).....	84
8.50	Diode Selection Register - Index 59h (Bank 0).....	84
8.51	Reserved Register - Index 5Ah ~ 5Ch (Bank 0) .....	85
8.52	VBAT Monitor Control Register - Index 5Dh (Bank 0) .....	85
8.53	Critical Temperature and Current Mode Enable Register - Index 5Eh (Bank 0) .....	86
8.54	Reserved Register - Index 5Fh (Bank 0) .....	87
8.55	CPUFANOUT1 PWM Output Frequency Configuration Register - Index 60h (Bank 0) .....	87
8.56	CPUFANOUT1 Output Value Select Register - Index 61h (Bank 0) .....	87
8.57	FAN Configuration Register III - Index 62h (Bank 0) .....	88
8.58	Target Temperature Register/CPUFANIN1 Target Speed Register - Index 63h (Bank 0)...	89
8.59	CPUFANOUT1 Stop Value Register - Index 64h (Bank 0).....	89
8.60	CPUFANOUT1 Start-up Value Register - Index 65h (Bank 0) .....	90
8.61	CPUFANOUT1 Stop Time Register - Index 66h (Bank 0).....	90
8.62	CPUFANOUT0 Maximum Output Value Register - Index 67h (Bank 0).....	91
8.63	CPUFANOUT0 Output Step Value Register - Index 68h (Bank 0).....	91
8.64	CPUFANOUT1 Maximum Output Value Register - Index 69h (Bank 0).....	92
8.65	CPUFANOUT1 Output Step Value Register - Index 6Ah (Bank 0).....	92
8.66	SYSFANOUT Critical Temperature register - Index 6Bh (Bank 0).....	93





8.67	CPUFANOUT0 Critical Temperature Register - Index 6Ch (Bank 0) .....	93
8.68	AUXFANOUT Critical Temperature Register - Index 6Dh (Bank 0) .....	93
8.69	CPUFANOUT1 Critical Temperature Register - Index 6Eh (Bank 0) .....	94
8.70	CPUTIN Temperature Sensor Temperature (High Byte) Register - Index 50h (Bank 1).....	94
8.71	CPUTIN Temperature Sensor Temperature (Low Byte) Register - Index 51h (Bank 1) .....	95
8.72	CPUTIN Temperature Sensor Configuration Register - Index 52h (Bank 1).....	95
8.73	CPUTIN Temperature Sensor Hysteresis (High Byte) Register - Index 53h (Bank 1) .....	96
8.74	CPUTIN Temperature Sensor Hysteresis (Low Byte) Register - Index 54h (Bank 1) .....	96
8.75	CPUTIN Temperature Sensor Over-temperature (High Byte) Register - Index 55h (Bank1)	97
8.76	CPUTIN Temperature Sensor Over-temperature (Low Byte) Register - Index 56h (Bank 1).....	97
8.77	AUXTIN Temperature Sensor Temperature (High Byte) Register - Index 50h (Bank 2).....	98
8.78	AUXTIN Temperature Sensor Temperature (Low Byte) Register - Index 51h (Bank 2).....	98
8.79	AUXTIN Temperature Sensor Configuration Register - Index 52h (Bank 2) .....	98
8.80	AUXTIN Temperature Sensor Hysteresis (High Byte) Register - Index 53h (Bank 2).....	99
8.81	AUXTIN Temperature Sensor Hysteresis (Low Byte) Register - Index 54h (Bank 2) .....	99
8.82	AUXTIN Temperature Sensor Over-temperature (High Byte) Register - Index 55h (Bank 2).....	100
8.83	AUXTIN Temperature Sensor Over-temperature (Low Byte) Register - Index 56h (Bank 2).....	100
8.84	Interrupt Status Register 3 - Index 50h (Bank 4) .....	101
8.85	SMI# Mask Register 4 - Index 51h (Bank 4) .....	102
8.86	Reserved Register - Index 52h (Bank 4).....	102
8.87	BEEP Control Register 3 - Index 53h (Bank 4).....	102
8.88	SYSTIN Temperature Sensor Offset Register - Index 54h (Bank 4) .....	103
8.89	CPUTIN Temperature Sensor Offset Register - Index 55h (Bank 4).....	103
8.90	AUXTIN Temperature Sensor Offset Register - Index 56h (Bank 4).....	104
8.91	Reserved Register - Index 57h-58h (Bank 4) .....	104
8.92	Real Time Hardware Status Register I - Index 59h (Bank 4).....	104
8.93	Real Time Hardware Status Register II - Index 5Ah (Bank 4) .....	105
8.94	Real Time Hardware Status Register III - Index 5Bh (Bank 4) .....	106
8.95	Reserved Register - Index 5Ch ~ 5Fh (Bank 4).....	107
8.96	Value RAM 2 — Index 50h-59h (Bank 5).....	107
8.97	Reserved Register - Index 50h ~ 57h (Bank 6) .....	107
9.	SERIAL PERIPHERAL INTERFACE .....	108
9.1	Using the SPI Interface via the LPC .....	108
10.	FLOPPY DISK CONTROLLER.....	111
10.1	FDC Functional Description .....	111
10.1.1	FIFO (Data).....	111
10.1.2	Data Separator.....	112
10.1.3	Write Precompensation.....	112
10.1.4	Perpendicular Recording Mode.....	112
10.1.5	FDC Core.....	112



10.1.6	FDC Commands .....	113
10.2	Register Descriptions .....	124
10.2.1	Status Register A (SA Register) (Read base address + 0) .....	124
10.2.2	Status Register B (SB Register) (Read base address + 1) .....	126
10.2.3	Digital Output Register (DO Register) (Write base address + 2).....	128
10.2.4	Tape Drive Register (TD Register) (Read base address + 3) .....	128
10.2.5	Main Status Register (MS Register) (Read base address + 4) .....	129
10.2.6	Data Rate Register (DR Register) (Write base address + 4) .....	129
10.2.7	FIFO Register (R/W base address + 5).....	131
10.2.8	Digital Input Register (DI Register) (Read base address + 7) .....	133
10.2.9	Configuration Control Register (CC Register) (Write base address + 7).....	134
11.	UART PORT .....	136
11.1	Universal Asynchronous Receiver/Transmitter (UART A, UART B).....	136
11.2	Register Description .....	136
11.2.1	UART Control Register (UCR) (Read/Write).....	136
11.2.2	UART Status Register (USR) (Read/Write).....	139
11.2.3	Handshake Control Register (HCR) (Read/Write).....	140
11.2.4	Handshake Status Register (HSR) (Read/Write) .....	140
11.2.5	UART FIFO Control Register (UFR) (Write only) .....	141
11.2.6	Interrupt Status Register (ISR) (Read only) .....	142
11.2.7	Interrupt Control Register (ICR) (Read/Write) .....	143
11.2.8	Programmable Baud Generator (BLL/BHL) (Read/Write) .....	143
11.2.9	User-defined Register (UDR) (Read/Write).....	144
12.	PARALLEL PORT .....	145
12.1	Printer Interface Logic .....	145
12.2	Enhanced Parallel Port (EPP).....	146
12.2.1	Data Port (Data Swapper).....	147
12.2.2	Printer Status Buffer .....	147
12.2.3	Printer Control Latch and Printer Control Swapper .....	147
12.2.4	EPP Address Port .....	148
12.2.5	EPP Data Port 0-3 .....	148
12.2.6	EPP Pin Descriptions .....	149
12.2.7	EPP Operation .....	149
12.3	Extended Capabilities Parallel (ECP) Port.....	150
12.3.1	ECP Register and Bit Map .....	151
12.3.2	Data and ecpAFifo Port.....	152
12.3.3	Device Status Register (DSR).....	152
12.3.4	Device Control Register (DCR) .....	153
12.3.5	CFIFO (Parallel Port Data FIFO) Mode = 010.....	153
12.3.6	ECPDFIFO (ECP Data FIFO) Mode = 011 .....	153
12.3.7	TFIFO (Test FIFO Mode) Mode = 110 .....	154
12.3.8	CNFGA (Configuration Register A) Mode = 111 .....	154
12.3.9	CNFGB (Configuration Register B) Mode = 111 .....	154



12.3.10	ECR (Extended Control Register) Mode = all .....	155
12.3.11	ECP Pin Descriptions .....	156
12.3.12	ECP Operation .....	157
12.3.13	FIFO Operation .....	158
12.3.14	DMA Transfers .....	158
12.3.15	Programmed I/O (NON-DMA) Mode .....	158
13.	KEYBOARD CONTROLLER .....	159
13.1	Output Buffer .....	159
13.2	Input Buffer .....	159
13.3	Status Register .....	160
13.4	Commands .....	160
13.5	Hardware GATEA20/Keyboard Reset Control Logic .....	162
13.5.1	KB Control Register .....	162
13.5.2	Port 92 Control Register .....	163
14.	POWER MANAGEMENT EVENT .....	164
14.1	Power Control Logic .....	164
14.1.1	PSON# Logic .....	165
14.1.2	AC Power Failure Resume .....	166
14.2	Wake Up the System by Keyboard and Mouse .....	167
14.2.1	Waken up by Keyboard events .....	167
14.2.2	Waken up by Mouse events .....	167
14.3	Resume Reset Logic .....	168
14.4	PWROK Generation .....	169
14.4.1	The Relation among PWROK/PWROK2, ATXPGD and FTRST# - both for UBE and UBF Version Only .....	170
15.	SERIALIZED IRQ .....	173
15.1	Start Frame .....	173
15.2	IRQ/Data Frame .....	174
15.3	Stop Frame .....	175
16.	WATCHDOG TIMER .....	176
17.	GENERAL PURPOSE I/O .....	177
18.	VID INPUTS AND OUTPUTS .....	178
18.1	VID Input Detection .....	178
18.2	VID Output Control .....	178
19.	PCI RESET BUFFERS .....	179
20.	CONFIGURATION REGISTER .....	180
20.1	Chip (Global) Control Register .....	180
20.2	Logical Device 0 (FDC) .....	187
20.3	Logical Device 1 (Parallel Port) .....	190
20.4	Logical Device 2 (UART A) .....	191
20.5	Logical Device 3 (UART B) .....	191
20.6	Logical Device 5 (Keyboard Controller) .....	193



20.7	Logical Device 6 (Serial Peripheral Interface).....	194
20.8	Logical Device 7 (GPIO6) .....	195
20.9	Logical Device 8 (WDTO# & PLED) .....	196
20.10	Logical Device 9 (GPIO2, GPIO3, GPIO4, GPIO5) .....	198
20.11	Logical Device A (ACPI).....	202
20.12	Logical Device B (Hardware Monitor) .....	210
20.13	Logical Device C (PECI, SST) .....	212
21.	SPECIFICATIONS .....	216
21.1	Absolute Maximum Ratings .....	216
21.2	DC CHARACTERISTICS .....	216
21.3	AC CHARACTERISTICS .....	225
21.3.1	AC Power Failure Resume Timing.....	225
21.3.2	VSBGATE# Timing – for UBE and UBF Version Only .....	230
21.3.3	Clock Input Timing .....	231
21.3.4	PECI and SST Timing.....	232
21.3.5	SPI Timing .....	233
21.3.6	SMBus Timing.....	234
21.3.7	Floppy Disk Drive Timing .....	235
21.3.8	UART/Parallel Port.....	236
21.3.9	Parallel Port Mode Parameters .....	238
21.3.10	Parallel Port .....	239
21.3.11	KBC Timing Parameters .....	248
21.3.12	GPIO Timing Parameters.....	251
21.4	LPC Timing.....	253
22.	TOP MARKING SPECIFICATION .....	254
23.	PACKAGE SPECIFICATION .....	255



## 1. GENERAL DESCRIPTION

The W83627DHG is a member of Winbond's Super I/O product line. This family features the LPC (Low Pin Count) interface. This interface is more economical than its ISA counterpart, in that it has approximately forty pins fewer, yet still provides as great performance. In addition, the improvement allows even more efficient operation of software, BIOS and device drivers.

In addition to providing an LPC interface for I/O, the W83627DHG monitors several critical parameters in PC hardware, including power supply voltages, fan speeds, and temperatures. In terms of temperature monitoring, the W83627DHG adopts the Current Mode (dual current source) approach. The W83627DHG also supports the Smart Fan control system, including "SMART FAN™ I and SMART FAN™ III, which makes the system more stable and user-friendly.

The W83627DHG supports four -- 360K, 720K, 1.2M, 1.44M, or 2.88M -- disk drive types and data transfer rates of 250 Kb/s, 300 Kb/s, 500 Kb/s, 1 Mb/s, and 2 Mb/s. The disk drive adapter supports the functions of floppy disk drive controller (compatible with the industry standard 82077/ 765), data separator, write pre-compensation circuit, decode logic, data rate selection, clock generator, drive interface control logic, and interrupt and DMA logic. Such a wide range of functions integrated into one W83627DHG greatly reduces the number of required components to interface with floppy disk drives.

The W83627DHG provides two high-speed serial communication ports (UARTs), one of which provides IR functions IrDA 1.0 (SIR for 1.152K bps). Each UART includes a 16-byte send/receive FIFO, a programmable baud rate generator, complete modem-control capability, and a processor interrupt system. Both UARTs support legacy speeds up to 115.2K bps as well as even higher baud rates of 230K, 460K, or 921K bps to support higher speed modems.

The W83627DHG supports the PC-compatible printer port (SPP), the bi-directional printer port (BPP), the enhanced parallel port (EPP) and the extended capabilities port (ECP).

The W83627DHG provides a bridge of the Low Pin Count interface to Serial Peripheral Interface (SPI) that supports up to 8M bits serial flash ROM. The W83627DHG provides flexible I/O control functions through a set of 40 general purpose I/O (GPIO) ports. These GPIO ports may serve as simple I/O ports or may be individually configured to provide alternative functions.

The W83627DHG supports the SST (Simple Serial Transport) interface and Intel® PECl (Platform Environment Control Interface).

The W83627DHG fully complies with the Microsoft© PC98, PC99 and PC2001 System Design Guides and meets the requirements of ACPI.

The configuration registers inside the W83627DHG support mode selection, function enable and disable, and power-down selection. Furthermore, the configurable PnP features are compatible with the plug-and-play feature in Windows 95/98/2000/XP™, making the allocation of the system resources more efficient than ever.

One special characteristic of the Super I/O product line is the separation of the power supply in normal operation from that in standby operation. Please pay attention to the layout of these two power supplies to avoid short circuits. Otherwise, the feature will not function.



## **2. FEATURES**

### **General**

- Meet LPC Spec. 1.01
- Support LDRQ# (LPC DMA), SERIRQ (Serialized IRQ)
- Integrated hardware monitor functions
- Compliant with Microsoft PC98/PC99/PC2001 System Design Guide
- Support DPM (Device Power Management), ACPI (Advanced Configuration and Power Interface)
- Programmable configuration settings
- Single 24- or 48-MHz clock input
- Support selective pins of 5 V tolerance

### **FDC**

- Variable write pre-compensation with track-selection capability
- Support vertical recording format
- DMA-enable logic
- 16-byte data FIFOs
- Support floppy disk drives and tape drives
- Detect all overrun and underrun conditions
- Built-in address mark detection circuit to simplify the read electronics
- FDD anti-virus functions with software write protect and FDD-write enable signal (write data signal forced to be inactive)
- Support 3.5-inch or 5.25-inch floppy disk drives
- Compatible with industry standard 82077
- 360K / 720K / 1.2M / 1.44M / 2.88M formats
- 250K, 300K, 500K, 1M, 2M bps data transfer rate
- Support 3-mode FDD and its Windows driver

### **UART**

- Two high-speed, 16550-compatible UARTs with 16-byte send / receive FIFOs
- Fully programmable serial-interface characteristics:
  - 5, 6, 7 or 8-bit characters
  - Even, odd or no parity bit generation/detection
  - 1, 1.5 or 2 stop-bit generation
- Internal diagnostic capabilities:
  - Loop-back controls for communications link fault isolation
  - Break, parity, overrun, framing error simulation
- Programmable baud rate generator allows division of clock source by any value from 1 to  $(2^{16} - 1)$
- Maximum baud rate for clock source 14.769 MHz is up to 921K bps. The baud rate at 24 MHz is 1.5 M bps.



## Parallel Port

- Compatible with IBM parallel port
- Support PS/2-compatible bi-directional parallel port
- Support Enhanced Parallel Port (EPP) - Compatible with IEEE 1284 specification
- Support Extended Capabilities Port (ECP) - Compatible with IEEE 1284 specification
- Enhanced printer port back-drive current protection

## Keyboard Controller

- 8042-based keyboard controller
- Asynchronous Access to two data registers and one status register
- Software-compatible with 8042
- Support PS/2 mouse
- Support Port 92
- Support both interrupt and polling modes
- Fast Gate A20 and Hardware Keyboard Reset
- 6, 8, 12, or 16 MHz operating frequency

## Hardware Monitor Functions

- Smart Fan control system, supporting the functions of SMART FAN™ I -- "Thermal Cruise™" and "Speed Cruise™" modes, and SMART FAN™ III
- Programmable threshold temperature to speed fan fully while current temperature exceeds this threshold in the Thermal Cruise™ mode
- Three thermal inputs from the different combinations of remote thermistors, and the thermal diode output
- Support Current Mode (dual current source) temperature sensing method
- Nine voltage inputs (CPUVCORE, VIN[0..3] and 3VCC, AVCC, 3VSB, VBAT)
- Five fan-speed monitoring inputs
- Four fan-speed controls
- Dual mode for fan control (PWM and DC)
- Built-in case open detection circuit
- Programmable hysteresis and setting points for all monitored items
- Over-temperature indicator output
- Issue SMI#, OVT# to activate system protection
- Winbond Hardware Doctor™ support
- Eight VID inputs / outputs
- Provide I<sup>2</sup>C interface to read / write registers

## Serial Peripheral Interface

- Support up to 8M bits SPI Flash Memory with clock up to 33 MHz
- Support Mode 0 and Mode 3



## **Infrared**

- Support IrDA version 1.0 SIR protocol with maximum baud rate up to 115.2K bps
- Support SHARP ASK-IR protocol with maximum baud rate up to 57,600 bps

## **General Purpose I/O Ports**

- 40 programmable general purpose I/O ports
- GPIO port 4 supports the optional functions of Watchdog Timer Out and Suspend LED Output
- GP30, GP31 and GP35 can distinguish whether the input pins undergo any transitions by reading the registers. All of the 3 GPIOs can assert PSOUT# or PME# to wake up the system if each of them undergoes any transition.

## **OnNow Functions**

- Keyboard Wake-Up by programmable keys
- Mouse Wake-Up by programmable buttons
- OnNow Wake-Up from all of the ACPI sleeping states (S1-S5)

## **Simple Serial Transport™ Interface**

- SST temperature and voltage Combination Sensor command support
- Support SST 0.9 Specification

## **PECI Interface**

- Support PECI 1.0 Specification
- Support 4 CPU addresses and 2 domains per CPU address

## **Package**

- 128-pin QFP
- Pb-free/RoHS





3. BLOCK DIAGRAM

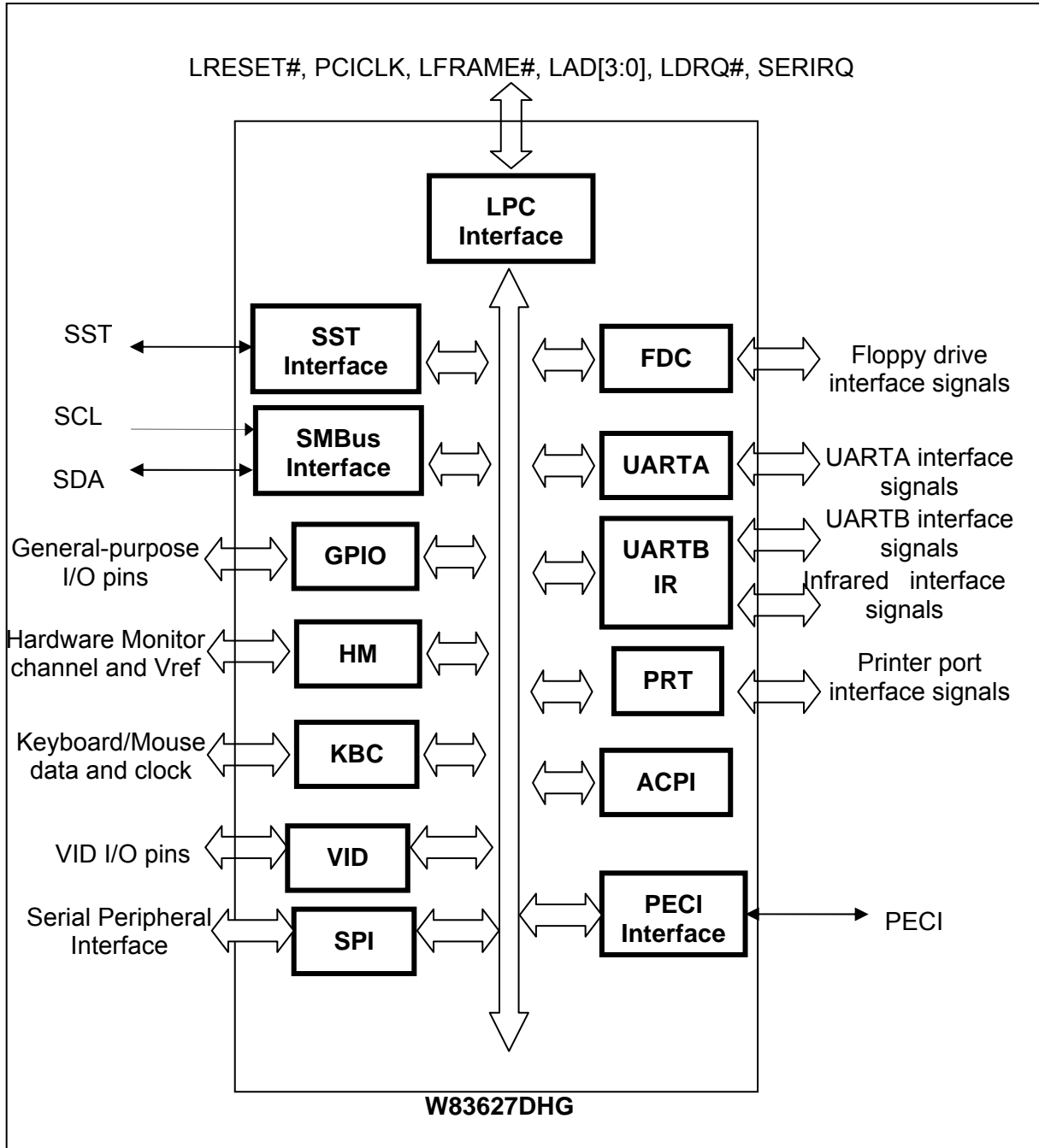



4. PIN LAYOUT

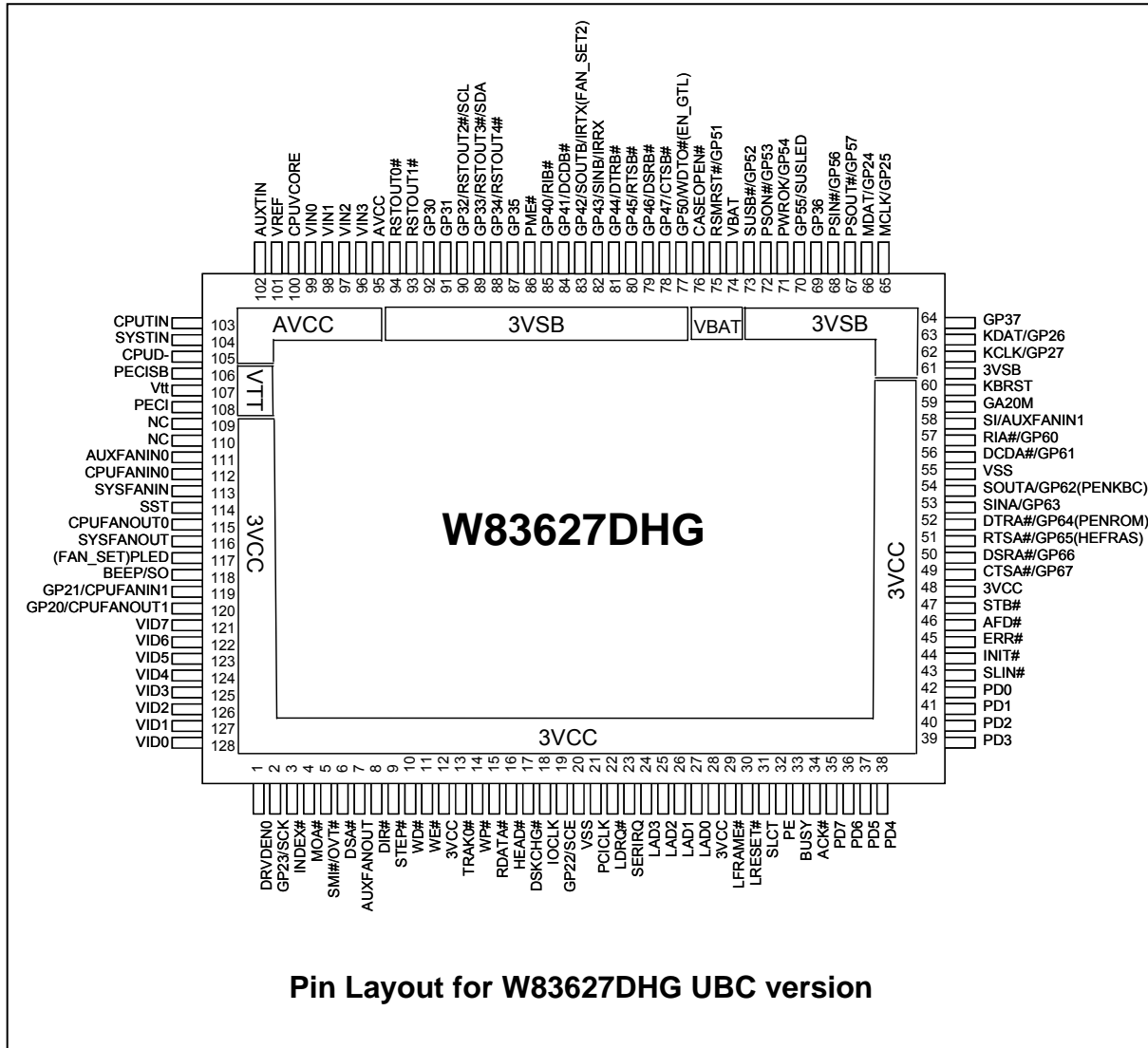

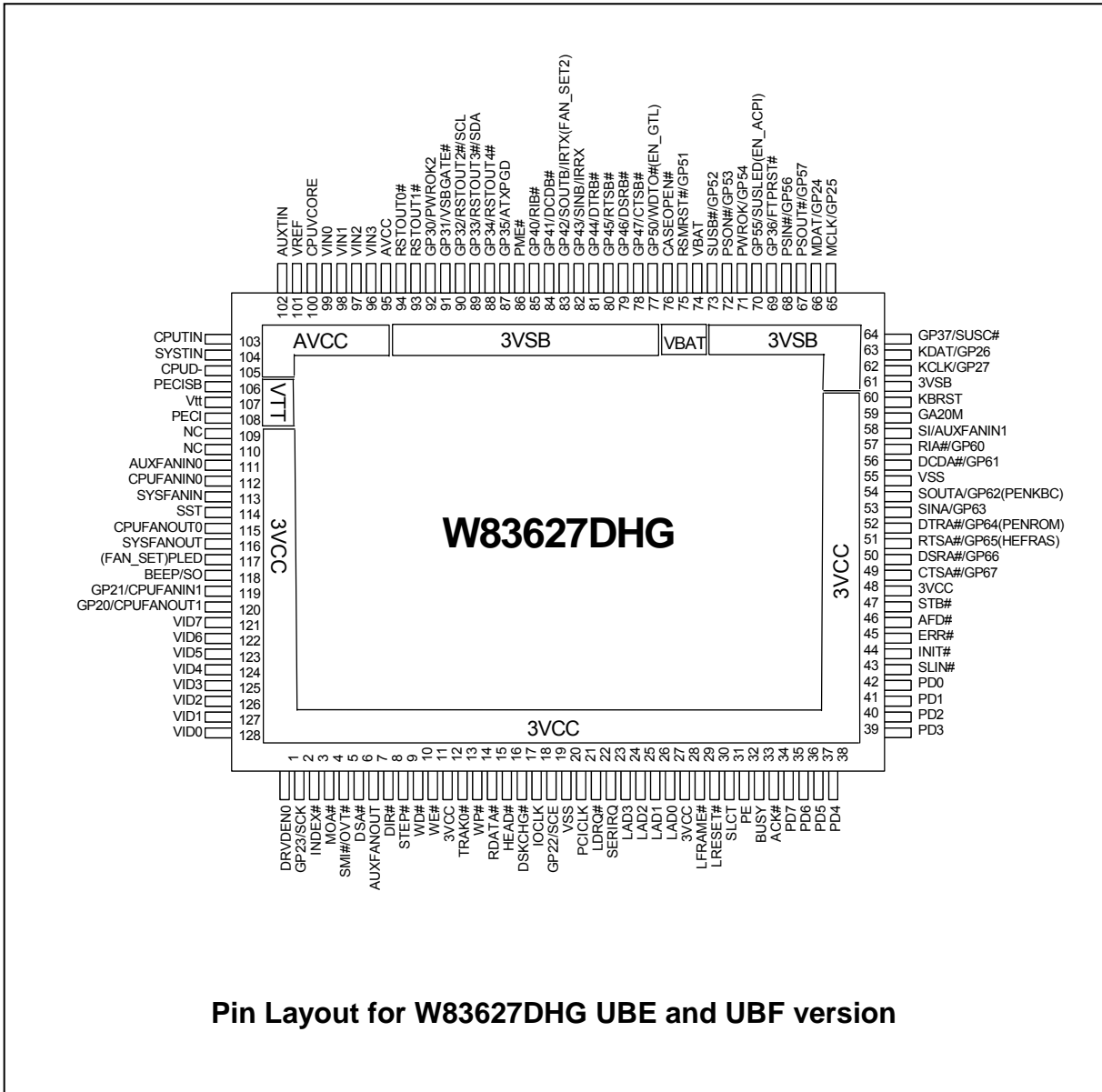

Pin Layout for W83627DHG UBE and UBF version



## 5. PIN DESCRIPTION

**Note:** Please refer to Section 21.2 DC CHARACTERISTICS for details.

AOUT	- Analog output pin
AIN	- Analog input pin
IN <sub>cd</sub>	- CMOS-level input pin with internal pull-down resistor
IN <sub>cs</sub>	- CMOS-level, Schmitt-trigger input pin
IN <sub>csu</sub>	- CMOS-level, Schmitt-trigger input pin with internal pull-up resistor
IN <sub>t</sub>	- TTL-level input pin
IN <sub>td</sub>	- TTL-level input pin with internal pull-down resistor
IN <sub>ts</sub>	- TTL-level, Schmitt-trigger input pin
IN <sub>tp3</sub>	- 3.3V, TTL-level input pin
IN <sub>tsp3</sub>	- 3.3V TTL level Schmitt-trigger input pin
IN <sub>tu</sub>	- TTL-level input pin with internal pull-up resistor
I/O <sub>8</sub>	- bi-directional pin with 8-mA source-sink capability
I/O <sub>8t</sub>	- TTL-level, bi-directional pin with 8-mA source-sink capability
I/O <sub>12</sub>	- bi-directional pin with 12-mA source-sink capability
I/O <sub>12t</sub>	- TTL-level, bi-directional pin with 12-mA source-sink capability
I/O <sub>12ts</sub>	- Schmitt-trigger, bi-directional pin with 12-mA source-sink capability
I/O <sub>12tp3</sub>	- 3.3V, TTL-level, bi-directional pin with 12-mA source-sink capability
I/OD <sub>8t</sub>	- TTL-level, bi-directional pin. Open-drain output with 8-mA sink capability
I/OD <sub>12</sub>	- Bi-directional pin. Open-drain output with 12-mA sink capability
I/OD <sub>12t</sub>	- TTL-level bi-directional pin. Open-drain output with 12-mA sink capability
I/OD <sub>12cs</sub>	- CMOS-level, bi-directional, Schmitt-trigger pin. Open-drain output with 12-mA sink capability
I/OD <sub>12ts</sub>	- TTL-level, bi-directional, Schmitt-trigger pin. Open-drain output with 12-mA sink capability
I/OD <sub>12tp3</sub>	- 3.3V, TTL-level, bi-directional pin. Open-drain output with 12-mA sink capability
I/OD <sub>16t</sub>	- TTL-level, bi-directional pin. Open-drain output with 16-mA sink capability
I/OD <sub>16ts</sub>	- Schmitt-trigger, bi-directional pin. Open-drain output with 16-mA sink capability
I/OD <sub>16cs</sub>	- CMOS-level, Schmitt-trigger, bi-directional pin. Open-drain output with 16-mA sink capability
I/OD <sub>24t</sub>	- TTL-level, bi-directional pin. Open-drain output with 24-mA sink capability
O <sub>12p3</sub>	- 3.3V output pin with 12-mA source-sink capability
O <sub>12tp3</sub>	- 3.3V, TTL-level output pin with 12-mA source-sink capability
O <sub>8</sub>	- TTL-level output pin with 8-mA source-sink capability
O <sub>12</sub>	- TTL-level output pin with 12-mA source-sink capability
O <sub>24</sub>	- TTL-level output pin with 24-mA source-sink capability
OD <sub>8</sub>	- Open-drain output pin with 8-mA sink capability
OD <sub>12</sub>	- Open-drain output pin with 12-mA sink capability
OD <sub>24</sub>	- Open-drain output pin with 24-mA sink capability
I/O <sub>v3</sub>	- Bi-direction pin with source capability of 6 mA and sink capability of 1 mA



## 5.1 LPC Interface

SYMBOL	PIN	I/O	DESCRIPTION
IOCLK	18	IN <sub>tp3</sub>	System clock input, either 24MHz or 48MHz. The actual frequency must be specified in the register. The default value is 48MHz.
PME#	86	OD <sub>12p3</sub>	Generated PME event.
PCICLK	21	IN <sub>tsp3</sub>	PCI-clock 33-MHz input.
LDRQ#	22	O <sub>12p3</sub>	Encoded DMA Request signal.
SERIRQ	23	I/OD <sub>12tp3</sub>	Serialized IRQ input / output.
LAD[3:0]	24-27	I/O <sub>12tp3</sub>	These signal lines communicate address, control, and data information over the LPC bus between a host and a peripheral.
LFRAME#	29	IN <sub>tsp3</sub>	Indicates the start of a new cycle or the termination of a broken cycle.
LRESET#	30	IN <sub>tsp3</sub>	Reset signal. It can be connected to the PCIRST# signal on the host.

## 5.2 FDC Interface

SYMBOL	PIN	I/O	DESCRIPTION
DRVDE0	1	OD <sub>24</sub>	Drive Density Select bit 0.
INDEX#	3	IN <sub>cs</sub>	This Schmitt-trigger input from the disk drive is active-low when the head is positioned over the beginning of a track marked by an index hole. This input pin needs to connect a pulled-up 1-K $\Omega$ resistor to 5V for Floppy Drive compatibility.
MOA#	4	OD <sub>24</sub>	Motor A On. When set to 0, this pin activates disk drive A. This is an open-drain output.
DSA#	6	OD <sub>24</sub>	Drive Select A. When set to 0, this pin activates disk drive A. This is an open-drain output.
DIR#	8	OD <sub>24</sub>	Direction of the head step motor. An open-drain output. Logic 1 = outward motion Logic 0 = inward motion
STEP#	9	OD <sub>24</sub>	Step output pulses. This active-low open-drain output produces a pulse to move the head to another track.
WD#	10	OD <sub>24</sub>	Write data. This logic-low open-drain writes pre-compensation serial data to the selected FDD. An open-drain output.
WE#	11	OD <sub>24</sub>	Write enable. An open-drain output.
TRAK0#	13	IN <sub>cs</sub>	Track 0. This Schmitt-trigger input from the disk drive is active-low when the head is positioned over the outermost track. This input pin needs to connect a pulled-up 1-K $\Omega$ resistor to 5V for Floppy Drive compatibility.



FDC Interface, continued

SYMBOL	PIN	I/O	DESCRIPTION
WP#	14	IN <sub>CS</sub>	Write protected. This active-low Schmitt input from the disk drive indicates that the diskette is write-protected. This input pin needs to connect a pulled-up 1-K $\Omega$ resistor to 5V for Floppy Drive compatibility.
RDATA#	15	IN <sub>CS</sub>	The read-data input signal from the FDD. This input pin needs to connect a pulled-up 1-K $\Omega$ resistor to 5V for Floppy Drive compatibility.
HEAD#	16	OD <sub>24</sub>	Head selection. This open-rain output determines which disk drive head is active. Logic 1 = side 0 Logic 0 = side 1
DSKCHG#	17	IN <sub>CS</sub>	Diskette change. This signal is active-low at power-on and whenever the diskette is removed. This input pin needs to connect a pulled-up 1-K $\Omega$ resistor to 5V for Floppy Drive compatibility.

### 5.3 Multi-Mode Parallel Port

SYMBOL	PIN	I/O	DESCRIPTION
SLCT	31	IN <sub>ts</sub>	PRINTER MODE: An active-high input on this pin indicates that the printer is selected. See the description of the parallel port for the definition of this pin in ECP and EPP modes.
PE	32	IN <sub>ts</sub>	PRINTER MODE: An active-high input on this pin indicates that the printer has detected the end of the paper. See the description of the parallel port for the definitions of this pin in ECP and EPP modes.
BUSY	33	IN <sub>ts</sub>	PRINTER MODE: An active-high input indicates that the printer is not ready to receive data. See the description of the parallel port for the definitions of this pin in ECP and EPP modes.
ACK#	34	IN <sub>ts</sub>	PRINTER MODE: ACK# An active-low input on this pin indicates that the printer has received data and is ready to accept more data. See the descriptions of the parallel port for the definition of this pin in ECP and EPP modes.
ERR#	45	IN <sub>ts</sub>	PRINTER MODE: ERR# An active-low input on this pin indicates that the printer has encountered an error condition. See the description of the parallel port for the definitions of this pin in ECP and EPP modes.
SLIN#	43	OD <sub>12</sub>	PRINTER MODE: SLIN# Output line for detection of printer selection. See the description of the parallel port for the definitions of this pin in ECP and EPP modes.



Multi-Mode Parallel Port, continued.

SYMBOL	PIN	I/O	DESCRIPTION
INIT#	44	OD <sub>12</sub>	PRINTER MODE: INIT# Output line for the printer initialization. See the description of the parallel port for the definitions of this pin in ECP and EPP modes.
AFD#	46	OD <sub>12</sub>	PRINTER MODE: AFD# An active-low output from this pin causes the printer to auto feed a line after a line is printed. See the description of the parallel port for the definitions of this pin in ECP and EPP modes.
STB#	47	OD <sub>12</sub>	PRINTER MODE: STB# An active-low output is used to latch the parallel data into the printer. See the description of the parallel port for the definitions of this pin in ECP and EPP modes.
PD0	42	I/O <sub>12ts</sub>	PRINTER MODE: PD0 Parallel port data bus bit 0. See the description of the parallel port for the definitions of this pin in ECP and EPP modes.
PD1	41	I/O <sub>12ts</sub>	PRINTER MODE: PD1 Parallel port data bus bit 1. See the description of the parallel port for the definitions of this pin in ECP and EPP modes.
PD2	40	I/O <sub>12ts</sub>	PRINTER MODE: PD2 Parallel port data bus bit 2. See the description of the parallel port for the definitions of this pin in ECP and EPP modes.
PD3	39	I/O <sub>12ts</sub>	PRINTER MODE: PD3 Parallel port data bus bit 3. See the description of the parallel port for the definitions of this pin in ECP and EPP modes.
PD4	38	I/O <sub>12ts</sub>	PRINTER MODE: PD4 Parallel port data bus bit 4. See the description of the parallel port for the definition of this pin in ECP and EPP modes.
PD5	37	I/O <sub>12ts</sub>	PRINTER MODE: PD5 Parallel port data bus bit 5. See the description of the parallel port for the definitions of this pin in ECP and EPP modes.
PD6	36	I/O <sub>12ts</sub>	PRINTER MODE: PD6 Parallel port data bus bit 6. See the description of the parallel port for the definitions of this pin in ECP and EPP modes.
PD7	35	I/O <sub>12ts</sub>	PRINTER MODE: PD7 Parallel port data bus bit 7. See the description of the parallel port for the definitions of this pin in ECP and EPP modes.



#### 5.4 Serial Port & Infrared Port Interface

SYMBOL	PIN	I/O	DESCRIPTION
RIA#	57	IN <sub>t</sub>	Ring Indicator. An active-low signal indicates that a ring signal is being received from the modem or the data set.
GP60		I/OD <sub>12t</sub>	General-purpose I/O port 6 bit 0.
DCDA#	56	IN <sub>t</sub>	Data Carrier Detection. An active-low signal indicates the modem or data set has detected a data carrier.
GP61		I/OD <sub>12t</sub>	General-purpose I/O port 6 bit 1.
SOUTA	54	O <sub>8</sub>	UART A Serial Output. This pin is used to transmit serial data out to the communication link.
PENKBC		IN <sub>t</sub>	During power on reset, this pin is pulled down internally and is defined as PENKBC, and the power-on values are shown at CR24 bit 2. The PCB layout should reserve space for a 1-kΩ resistor to pull down this pin to ensure the disabling of KBC, and a 1-kΩ resistor is recommended to pull the pin up if wish to enable KBC.
GP62		I/O <sub>8</sub>	General-purpose I/O port 6 bit 2.
SINA	53	IN <sub>t</sub>	Serial Input. This pin is used to receive serial data through the communication link.
GP63		I/OD <sub>12t</sub>	General-purpose I/O port 6 bit 3.
DTRA#	52	O <sub>8</sub>	UART A Data Terminal Ready. An active-low signal informs the modem or data set that the controller is ready to communicate.
PENROM		IN <sub>t</sub>	During power-on reset, this pin is pulled down internally and is defined as PENROM disabled, and the power-on values are shown at CR24 bit 1 (ENROM). The PCB layout should reserve space for a 1-kΩ resistor to pull down this pin to ensure the disabling of SPI interface, and a 1-kΩ resistor is recommended to pull the pin up if wish to enable ROM.
GP64		I/O <sub>8</sub>	General-purpose I/O port 6 bit 4.
RTSA#	51	O <sub>8</sub>	UART A Request To Send. An active-low signal informs the modem or data set that the controller is ready to send data.
HEFRAS		IN <sub>t</sub>	During power-on reset, this pin is pulled down internally and is defined as HEFRAS, which provides the power-on value for CR26 bit 6 (HEFRAS). The PCB layout should reserve space for a 1-kΩ resistor to pull down this pin so as to ensure the selection of I/O port's configuration address to 2EH, and a 1-kΩ resistor is recommended to pull it up if 4EH is selected as I/O port's configuration address.
GP65		I/O <sub>8</sub>	General-purpose I/O port 6 bit 5.
DSRA#	50	IN <sub>t</sub>	Data Set Ready. An active-low signal indicates the modem or data set is ready to establish a communication link and transfer data to the UART.
GP66		I/OD <sub>12t</sub>	General-purpose I/O port 6 bit 6.





Serial Port &amp; Infrared Port Interface , continued.

SYMBOL	PIN	I/O	DESCRIPTION
CTSA#	49	IN <sub>t</sub>	Clear To Send. This is the modem-control input. The function of these pins can be tested by reading bit 4 of the handshake status register.
GP67		I/OD <sub>12t</sub>	General-purpose I/O port 6 bit 7.
RIB#	85	IN <sub>t</sub>	Ring Indicator. An active-low signal indicates that a ring signal is being received from the modem or the data set.
GP40*		I/OD <sub>12t</sub>	General-purpose I/O port 4 bit 0.
DCDB#	84	IN <sub>t</sub>	Data Carrier Detection. An active-low signal indicates the modem or data set has detected a data carrier.
GP41***		I/OD <sub>12t</sub>	General-purpose I/O port 4 bit 1.
FAN_SET2	83	IN <sub>t</sub>	Determines the initial FAN speed. Power-on configuration for 2 fan speeds, 50% or 100%. When VCC is on, this pin needs a pulled-up or a pulled-down resistor to decide whether the fan speed is 50% or 100%. Only CPUFANOUT1 is supported.
SOUTB		O <sub>12</sub>	UART B Serial Output. This pin is used to transmit serial data out to the communication link.
IRTX			IR Transmitter output.
GP42*		I/O <sub>12t</sub>	General-purpose I/O port 4 bit 2. Note: This pin changes to input state during internal PWROK from low to high, then goes back to the previous setting state. (Please see the AP Note 1 of W83627DHG)
SINB	82	IN <sub>t</sub>	Serial Input. This pin is used to receive serial data through the communication link.
IRRX			IR Receiver input.
GP43***		I/OD <sub>12t</sub>	General-purpose I/O port 4 bit 3.
DTRB#	81	O <sub>12</sub>	UART B Data Terminal Ready. An active-low signal informs the modem or data set that the controller is ready to communicate.
GP44*		I/OD <sub>12t</sub>	General-purpose I/O port 4 bit 4.
RTSB#	80	O <sub>12</sub>	UART B Request To Send. An active-low signal informs the modem or data set that the controller is ready to send data.
GP45***		I/OD <sub>12t</sub>	General-purpose I/O port 4 bit 5.
DSRB#	79	IN <sub>t</sub>	Data Set Ready. An active-low signal indicates the modem or data set is ready to establish a communication link and transfer data to the UART.
GP46*		I/OD <sub>12t</sub>	General-purpose I/O port 4 bit 6.
CTSB#	78	IN <sub>t</sub>	Clear To Send. This is the modem-control input. The function of these pins can be tested by reading bit 4 of the handshake status register.
GP47***		I/OD <sub>12t</sub>	General-purpose I/O port 4 bit 7.

**Note:** Regarding the \* sign, please see 5.11.8 GPIO-4 for detailed WDTO# / SUSLED multi-function information.



## 5.5 KBC Interface

SYMBOL	PIN	I/O	DESCRIPTION
GA20M	59	O <sub>12</sub>	Gate A20 output. This pin is high after system reset. (KBC P21)
KBRST	60	O <sub>12</sub>	Keyboard reset. This pin is high after system reset. (KBC P20)
KCLK	62	I/OD <sub>16ts</sub>	Keyboard Clock.
GP27		I/OD <sub>16t</sub>	General-purpose I/O port 2 bit 7.
KDAT	63	I/OD <sub>16ts</sub>	Keyboard Data.
GP26		I/OD <sub>16t</sub>	General-purpose I/O port 2 bit 6.
MCLK	65	I/OD <sub>16ts</sub>	PS2 Mouse Clock.
GP25		I/OD <sub>16t</sub>	General-purpose I/O port 2 bit 5.
MDAT	66	I/OD <sub>16ts</sub>	PS2 Mouse Data.
GP24		I/OD <sub>16t</sub>	General-purpose I/O port 2 bit 4.

## 5.6 Serial Peripheral Interface

The SPI employs a master-slave model and typically has three signal lines: serial data input line (SI), serial data output line (SO), and serial clock line (SCK). Different slaves are addressed on the bus by chip select signals from the master. The data bits are first shifted in/out the most significant bit (MSB). The data are often shifted simultaneously out from the output pin and into the input pin. Among the parameters, only the communication lines and the clock edge are defined by the SPI. The others differ from device to device.

### SPI Operation

To initiate the data transfer between the W83627DHG and a slave device, SCE# must go low. This synchronizes the slave device with the W83627DHG. Data can now be transferred between the W83627DHG and the slave device in one of two modes: the data is sampled either on the rising or the falling edge of the clock.

In a slave device, a logic low is received on the SCE# line and the clock input is at the SCK pin, which synchronizes the slave with the W83627DHG. Data is then received serially at the SI pin. During a write cycle, data is shifted out to the SO pin on clocks from the W83627DHG.



SYMBOL	PIN	I/O	DESCRIPTION
SCE#	19	O <sub>12</sub>	Serial flash ROM interface chip selection.
GP22		I/OD <sub>12t</sub>	General-purpose I/O port 2 bit 2.
SCK	2	O <sub>12</sub>	Clock output for serial flash. *UBC, UBE and UBF version support 33 MHz frequency, but UBE and UBF version use 16 MHz frequency as their default.
GP23		I/OD <sub>12t</sub>	General-purpose I/O port 2 bit 3.
SO	118	O <sub>8</sub>	Transfer commands, addresses or data to serial flash. This pin is connected to SI of serial flash.
BEEP		OD <sub>8</sub>	Beep function for hardware monitor. This pin is low after system reset.
SI	58	IN <sub>ts</sub>	Receive data from serial flash. This pin is connected to SO of serial flash.
AUXFANIN1		I/O <sub>12ts</sub>	0 to +3 V amplitude fan tachometer input.

### 5.7 Hardware Monitor Interface

SYMBOL	PIN	I/O	DESCRIPTION
BEEP	118	OD <sub>8</sub>	Beep function for hardware monitor. This pin is low after system reset.
SO		O <sub>8</sub>	Transfer commands, address or data to serial flash. This pin is connected to SI of serial flash.
CASEOPEN#	76	IN <sub>t</sub>	CASE OPEN detection. An active-low input from an external device when the case is open. This signal can be latched if pin VBAT is connected to the battery, even if the W83627DHG is turned off. Pulling up a 2-MΩ resistor to VBAT is recommended if not in use.
VIN3	96	AIN	Analog Inputs for voltage measurement (Range: 0 to 2.048 V)
VIN2	97	AIN	Analog Inputs for voltage measurement (Range: 0 to 2.048 V)
VIN1	98	AIN	Analog Inputs for voltage measurement (Range: 0 to 2.948 V)
VIN0	99	AIN	Analog Inputs for voltage measurement (Range: 0 to 2.048 V)
CPUVCORE	100	AIN	Analog Inputs for voltage measurement (Range: 0 to 2.048 V)
VREF	101	AOUT	Reference Voltage (2.048 V).
AUXTIN	102	AIN	The input of temperature sensor 3. It is used for temperature sensing.
CPUTIN	103	AIN	The input of temperature sensor 2. It is used for CPU temperature sensing.



Hardware Monitor Interface, continued.

SYMBOL	PIN	I/O	DESCRIPTION		
SYSTIN	104	AIN	The input of temperature sensor 1. It is used for system temperature sensing.		
OVT#	5	OD <sub>12</sub>	The output of over temperature Shutdown. This pin indicates the temperature is over the temperature limit. (Default after LRESET#)		
SMI#		OD <sub>12</sub>	System Management Interrupt channel output.		
VID7 VID6 VID5 VID4 VID3 VID2 VID1 VID0	121 122 123 124 125 126 127 128	I/O <sub>12</sub>	VID input detection, also with output control.		
AUXFANIN1	58			I/O <sub>12ts</sub>	0 to +3 V amplitude fan tachometer input.
SI				IN <sub>ts</sub>	Receive data from serial flash. This pin is connected to SO of serial flash..
AUXFANIN0	111			I/O <sub>12ts</sub>	0 to +3 V amplitude fan tachometer input.
CPUFANIN0	112				
SYSFANIN	113				
CPUFANIN1	119			I/O <sub>12ts</sub>	0 to +3 V amplitude fan tachometer input. (Default)
GP21				I/OD <sub>12t</sub>	General-purpose I/O port 2 bit 1.
AUXFANOUT	7	AOUT/ OD <sub>12</sub> / O <sub>12</sub>	DC/PWM fan output control. CPUFANOUT0 and AUXFANOUT are default PWM mode, CPUFANOUT1 and SYSFANOUT are default DC mode.		
CPUFANOUT0	115				
SYSFANOUT	116				
CPUFANOUT1	120	AOUT/ O <sub>12</sub> / OD <sub>12</sub>	DC/PWM fan output control. (Default) CPUFANOUT0 and AUXFANOUT are default PWM mode, CPUFANOUT1 and SYSFANOUT are default DC mode.		
GP20		I/OD <sub>12t</sub>	General-purpose I/O port 2 bit 0.		
FAN_SET	117	IN <sub>td</sub>	Determines the initial FAN speed. Power on configuration for 2 fan speeds, 50% or 100%. During power-on reset, this pin is pulled down internally and the fan speed is 50%. Only CPUFANOUT0 is supported.		
PLED		O <sub>12</sub>	Power LED output. Drive high 3.3 V after strapping.		



## 5.8 PECE Interface

SYMBOL	PIN	I/O	DESCRIPTION
PECE	108	I/O <sub>V3</sub>	INTEL® CPU PECE interface. Connect to CPU.
Vtt	107	Power	INTEL® CPU Vtt Power. This pin is connected to GND if the PECE function is not in use.
PECEISB	106	I/O <sub>V3</sub>	INTEL® CPU PECE interface. Connect to ICH8.

## 5.9 SST Interface

SYMBOL	PIN	I/O	DESCRIPTION
SST	114	I/O <sub>V4</sub>	Simple Serial Transport (SST) Interface.

## 5.10 Advanced Configuration and Power Interface

The Advanced Configuration and Power Interface (ACPI) is an interface that allows OS-directed Power Management (OSPM). The ACPI replaces the APM (Advanced Power Management), MPS (Multiprocessor Specification), and PnP BIOS Specification. In addition to power management, the ACPI supports the functions of thermal management, state management, and speed control, as well as the global system states and different device power states. Two of the primary states that the W83627DHG supports are the S0 (working) and S3 (suspend to RAM) states. S0 is a full-power state, in which the computer is actively used. S3 is a sleeping state, in which the processor is powered down, but the memory, where the last procedural state is stored, is still active. By employing the ACPI, the system conserves more energy through transiting unused devices into lower power states, including placing the entire system in a low-power state when possible.

SYMBOL	PIN	I/O	DESCRIPTION
PSIN#	68	IN <sub>tu</sub>	Panel Switch Input. This pin is active-low with an internal pulled-up resistor.
GP56		I/OD <sub>12t</sub>	General-purpose I/O port 5 bit 6.
PSOUT#	67	OD <sub>12</sub>	Panel Switch Output. This signal is used to wake-up the system from S3/S5 state.
GP57		I/OD <sub>12t</sub>	General-purpose I/O port 5 bit 7.
RSMRST#	75	OD <sub>12</sub>	Resume reset signal output.
GP51		I/OD <sub>12t</sub>	General-purpose I/O port 5 bit 1.
SUSB#	73	IN <sub>t</sub>	System S3 state input.
GP52		I/OD <sub>12t</sub>	General-purpose I/O port 5 bit 2.
PSON#	72	OD <sub>12</sub>	Power supply on-off output.
GP53		I/OD <sub>12t</sub>	General-purpose I/O port 5 bit 3.
PWROK	71	OD <sub>12</sub>	This pin generates the PWROK signal while 3VCC comes in.
GP54		I/OD <sub>12t</sub>	General-purpose I/O port 5 bit 4.



Continued

SYMBOL	PIN	I/O	DESCRIPTION
RSTOUT0#	94	OD <sub>12</sub>	PCI Reset Buffer 0.
RSTOUT1#	93	O <sub>12</sub>	PCI Reset Buffer 1.
RSTOUT2#	90	O <sub>12</sub>	PCI Reset Buffer 2. (Default)
GP32		I/OD <sub>12t</sub>	General-purpose I/O port 3 bit 2.
SCL		IN <sub>ts</sub>	Serial Bus clock.
RSTOUT3#	89	O <sub>12</sub>	PCI Reset Buffer 3. (Default)
GP33		I/OD <sub>12t</sub>	General-purpose I/O port 3 bit 3.
SDA		I/OD <sub>12ts</sub>	Serial bus bi-directional Data.
RSTOUT4#	88	O <sub>12</sub>	PCI Reset Buffer 4. (Default)
GP34		I/OD <sub>12t</sub>	General-purpose I/O port 3 bit 4.

## 5.11 General Purpose I/O Port

### 5.11.1 SMBus Interface

SYMBOL	PIN	I/O	DESCRIPTION
RSTOUT2#	90	O <sub>12</sub>	PCI Reset Buffer 2. (Default)
GP32		I/OD <sub>12t</sub>	General-purpose I/O port 3 bit 2.
SCL		IN <sub>ts</sub>	Serial Bus clock.
RSTOUT3#	89	O <sub>12</sub>	PCI Reset Buffer 3. (Default)
GP33		I/OD <sub>12t</sub>	General-purpose I/O port 3 bit 3.
SDA		I/OD <sub>12ts</sub>	Serial bus bi-directional Data.

### 5.11.2 GPIO Power Source

SYMBOL	POWER SOURCE
GPIO port 2 (Bit0-3)	3VCC
GPIO port 2 (Bit4-7)	3VSB
GPIO port 3	3VSB
GPIO port 4	3VSB
GPIO port 5	3VSB
GPIO port 6	3VCC



### 5.11.3 GPIO-2 Interface

SYMBOL	PIN	I/O	DESCRIPTION
GP20	120	I/OD <sub>12t</sub>	General-purpose I/O port 2 bit 0.
CPUFANOUT1		AOUT/ OD <sub>12t</sub> / O <sub>12</sub>	DC/PWM fan output control. (Default) CPUFANOUT0 and AUXFANOUT are default PWM mode, CPUFANOUT1 and SYSFANOUT are default DC mode.
GP21	119	I/OD <sub>12t</sub>	General-purpose I/O port 2 bit 1.
CPUFANIN1		I/O <sub>12ts</sub>	0 to +3 V amplitude fan tachometer input. (Default)
GP22	19	I/OD <sub>12t</sub>	General-purpose I/O port 2 bit 2.
SCE#		O <sub>12</sub>	Serial flash ROM interface chip selection.
GP23	2	I/OD <sub>12t</sub>	General-purpose I/O port 2 bit 3.
SCK		O <sub>12</sub>	Clock output for serial flash. *UBC, UBE and UBF version support 33 MHz frequency, but UBE and UBF version use 16 MHz frequency as their default.
GP24	66	I/OD <sub>16t</sub>	General-purpose I/O port 2 bit 4.
MDAT		I/OD <sub>16ts</sub>	PS2 Mouse Data.
GP25	65	I/OD <sub>16t</sub>	General-purpose I/O port 2 bit 5.
MCLK		I/OD <sub>16ts</sub>	PS2 Mouse Clock.
GP26	63	I/OD <sub>16t</sub>	General-purpose I/O port 2 bit 6.
KDAT		I/OD <sub>16ts</sub>	Keyboard Data.
GP27	62	I/OD <sub>16t</sub>	General-purpose I/O port 2 bit 7.
KCLK		I/OD <sub>16ts</sub>	Keyboard Clock.



#### 5.11.4 GPIO-3 Interface

SYMBOL	PIN	I/O	DESCRIPTION
RSTOUT0#	94	OD <sub>12</sub>	PCI Reset Buffer 0.
RSTOUT1#	93	O <sub>12</sub>	PCI Reset Buffer 1.
GP30	92	I/OD <sub>12t</sub>	General-purpose I/O port 3 bit 0.
PWROK2		OD <sub>12</sub>	This pin generates the PWROK2 signal while 3VCC comes in. (This pin function is both for UBE and UBF version only)
GP31	91	I/OD <sub>12t</sub>	General-purpose I/O port 3 bit 1.
VSBGATE#		O <sub>12</sub>	Switch 3VSB power to memory when in S3 state. The default is disabled while the particular ACPI functions are enabled. The control bit is at Logical Device A, CR[E4h] bit 4.(This pin function is both for UBE and UBF version only)
GP32	90	I/OD <sub>12t</sub>	General-purpose I/O port 3 bit 2.
RSTOUT2#		O <sub>12</sub>	PCI Reset Buffer 2. (Default)
SCL		IN <sub>ts</sub>	Serial Bus clock.
GP33	89	I/OD <sub>12t</sub>	General-purpose I/O port 3 bit 3.
RSTOUT3#		O <sub>12</sub>	PCI Reset Buffer 3. (Default)
SDA		I/OD <sub>12ts</sub>	Serial bus bi-directional Data.
GP34	88	I/OD <sub>12t</sub>	General-purpose I/O port 3 bit 4.
RSTOUT4#		O <sub>12</sub>	PCI Reset Buffer 4. (Default)
GP35	87	I/OD <sub>12t</sub>	General-purpose I/O port 3 bit 5.
ATXPGD		IN <sub>t</sub>	ATX power good input signal. It is connected to the PWROK signal from the power supply for PWROK/PWROK2 generation. The default is enabled.(This pin function is both for UBE and UBF version only)
GP36	69	I/OD <sub>12t</sub>	General-purpose I/O port 3 bit 6.
FTRST#		IN <sub>t</sub>	Connect to the reset button. This pin has internal de-bounce circuit whose de-bounce time is at least 32 mS. (This pin function is both for UBE and UBF version only)
GP37	64	I/OD <sub>12t</sub>	General-purpose I/O port 3 bit 7.
SUSC#		IN <sub>t</sub>	SLP_S5# input. (This pin function is both for UBE and UBF version only)

#### 5.11.5 GPIO-4 Interface

See 5.4 Serial Port & Infrared Port Interface





### 5.11.6 GPIO-5 Interface

SYMBOL	PIN	I/O	DESCRIPTION
GP50	77	I/O <sub>12t</sub>	General-purpose I/O port 5 bit 0. (Default after strapping)
EN_GTL		IN <sub>cu</sub>	During VSB power reset (RSMRST), this pin is pulled high internally and is defined as VID transition voltage level (GTL or TTL), and the value is shown at CR2C bit 3. The PCB layout should reserve space for a 1-kΩ resistor to pull down this pin if TTL is the selected VID level.
WDTO#		O <sub>12</sub>	Watchdog Timer output signal.
GP51	75	I/OD <sub>12t</sub>	General-purpose I/O port 5 bit 1.
RSMRST#		OD <sub>12</sub>	Resume reset signal output.
GP52	73	I/OD <sub>12t</sub>	General-purpose I/O port 5 bit 2.
SUSB#		IN <sub>t</sub>	System S3 state input.
GP53	72	I/OD <sub>12t</sub>	General-purpose I/O port 5 bit 3.
PSON#		OD <sub>12</sub>	Power supply on-off output.
GP54	71	I/OD <sub>12t</sub>	General-purpose I/O port 5 bit 4.
PWROK		OD <sub>12</sub>	This pin generates the PWROK signal while 3VCC comes in.
GP55	70	I/O <sub>12t</sub>	General-purpose I/O port 5 bit 5. (Default)
EN ACPI		IN <sub>cd</sub>	During VSB power reset (RSMRST), this pin is pulled down internally and is defined as EN ACPI (enabling particular ACPI functions), which provides the value for CR2C bit 4 (EN ACPI). The PCB layout should reserve space for a 1-kΩ resistor to pull down this pin to ensure successful disabling of particular ACPI functions, and a 1-kΩ resistor is recommended to pull the pin up if wish to enable particular ACPI functions. (This pin function is both for UBE and UBF version only)
SUSLED		O <sub>12</sub>	Suspended LED output.
GP56	68	I/OD <sub>12t</sub>	General-purpose I/O port 5 bit 6.
PSIN#		IN <sub>tu</sub>	Panel Switch Input. This pin is active-low with an internal pulled-up resistor.
GP57	67	I/OD <sub>12t</sub>	General-purpose I/O port 5 bit 7.
PSOUT#		OD <sub>12</sub>	Panel Switch Output. This signal is used to wake-up the system from S3/S5 state.

### 5.11.7 GPIO-6 Interface

See 5.4 Serial Port & Infrared Port Interface



### 5.11.8 GPIO-4 with WDIO# / SUSLED Multi-function

SYMBOL	PIN	I/O	DESCRIPTION
GPxx*	---	I/OD <sub>12t</sub>	This GPxx* can serve as GPIO or the Watchdog Timer output signals.
WDIO#		OD <sub>12</sub>	
GPxx***	---	I/OD <sub>12t</sub>	This GPxx*** can serve as GPIO or Suspend-LED output signals.
SUSLED		OD <sub>12</sub>	

### 5.12 Particular ACPI Function pins – both for UBE and UBF Version Only

SYMBOL	PIN	I/O	DESCRIPTION
SUSC#	64	IN <sub>t</sub>	SLP_S5# input. (This pin function is both for UBE and UBF version only)
GP37		I/OD <sub>12t</sub>	General-purpose I/O port 3 bit 7
EN_ACPI	70	IN <sub>cd</sub>	During VSB power reset (RSMRST), this pin is pulled down internally and is defined as EN_ACPI (enabling particular ACPI functions), which provides the value for CR2C bit 4 (EN_ACPI). The PCB layout should reserve space for a 1-kΩ resistor to pull down this pin to ensure successful disabling of particular ACPI functions, and a 1-kΩ resistor is recommended to pull the pin up if wish to enable particular ACPI functions. (This pin function is both for UBE and UBF version only)
GP55		I/O <sub>12t</sub>	General-purpose I/O port 5 bit 5.
SUSLED		O <sub>12</sub>	Suspended LED output.
VSBGATE#	91	O <sub>12</sub>	Switch 3VSB power to memory when in S3 state. The default is disabled while the particular ACPI functions are enabled. The control bit is at Logical Device A, CR[E4h] bit 4. (This pin function is both for UBE and UBF version only)
GP31		I/OD <sub>12t</sub>	General-purpose I/O port 3 bit 1.
PWROK2	92	OD <sub>12</sub>	This pin generates the PWROK2 signal while 3VCC comes in. (This pin function is both for UBE and UBF version only)
GP30		I/OD <sub>12t</sub>	General-purpose I/O port 3 bit 0.
ATXPGD	87	IN <sub>t</sub>	ATX power good input signal. It is connected to the PWROK signal from the power supply for PWROK/PWROK2 generation. The default is enabled. (This pin function is both for UBE and UBF version only)
GP35		I/OD <sub>12</sub>	General-purpose I/O port 3 bit 5.
FTRST#	69	IN <sub>t</sub>	Connect to the reset button. This pin has internal de-bounce circuit whose de-bounce time is at least 32 mS. (This pin function is both for UBE and UBF version only)
GP36		I/OD <sub>12</sub>	General-purpose I/O port 3 bit 6.

**5.13 POWER PINS**

<b>SYMBOL</b>	<b>PIN</b>	<b>DESCRIPTION</b>
3VSB	61	+3.3 V stand-by power supply for the digital circuits.
VBAT	74	+3 V on-board battery for the digital circuits.
3VCC	12,28,48	+3.3 V power supply for driving 3 V on host interface.
AVCC	95	Analog +3.3 V power input. Internally supply power to all analog circuits.
CPUD-(AGND)	105	Analog ground. The ground reference for all analog input. Internally connected to all analog circuits.
VSS	20,55	Ground.
Vtt	107	INTEL <sup>®</sup> CPU Vtt power.



## 6. CONFIGURATION REGISTER ACCESS PROTOCOL

The W83627DHG uses Super I/O protocol to access configuration registers to set up different types of configurations. The W83627DHG has totally twelve Logical Devices (from Logical Device 0 to Logical Device C with the exception of Logical Device 4 for backward compatibility) corresponding to twelve individual functions: FDC (Logical Device 0), Parallel Port (Logical Device 1), UARTA (Logical Device 2), UARTB (Logical Device 3), Keyboard Controller (Logical Device 5), SPI (Serial Peripheral Interface, Logical Device 6), GPIO6 (Logical Device 7), WDTO# & PLED (Logical Device 8), GPIO2, 3, 4, 5 (Logical Device 9), ACPI (Logical Device A), Hardware Monitor (Logical Device B), and PECL & SST (Logical Device C). Each Logical Device has its own configuration registers (above CR30). The host can access those registers by writing an appropriate Logical Device Number into the Logical Device select register at CR7. Please note that GPIO1 is not defined in the W83627DHG.

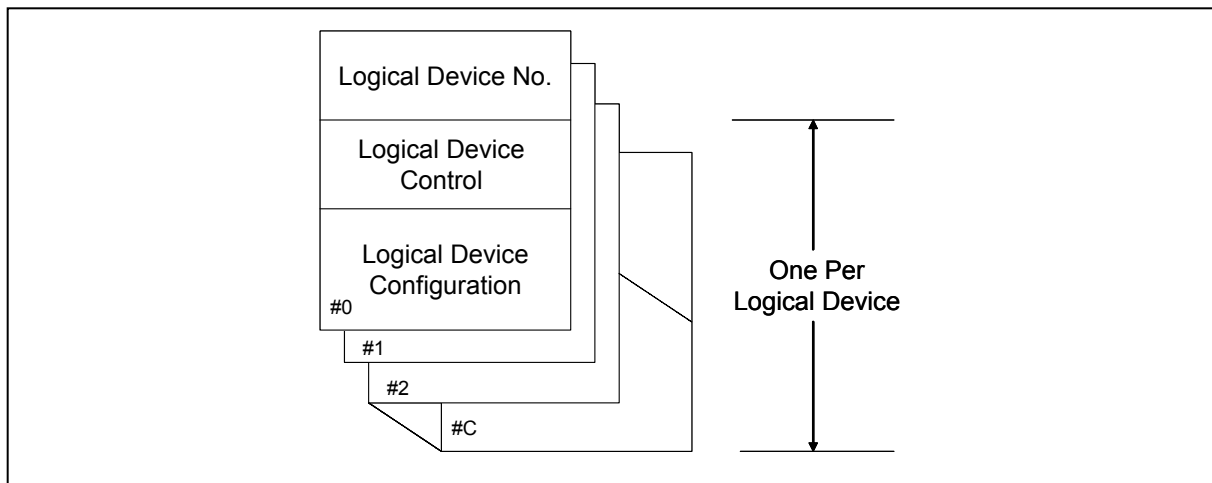

### Devices of I/O Base Address

LOGICAL DEVICE NUMBER	FUNCTION	I/O BASE ADDRESS
0	FDC	100h ~ FF8h
1	Parallel Port	100h ~ FF8h
2	UART A	100h ~ FF8h
3	UART B	100h ~ FF8h
4	Reserved	
5	Keyboard Controller	100h ~ FFFh
6	Serial Peripheral Interface	100h ~ FF8h
7	GPIO 6	100h ~ FFFh
8	WDTO# & PLED	Reserved
9	GPIO 2, 3, 4, 5	Reserved
A	ACPI	Reserved
B	Hardware Monitor	100h ~ FFEh
C	PECL & SST	Reserved



## 6.1 Configuration Sequence

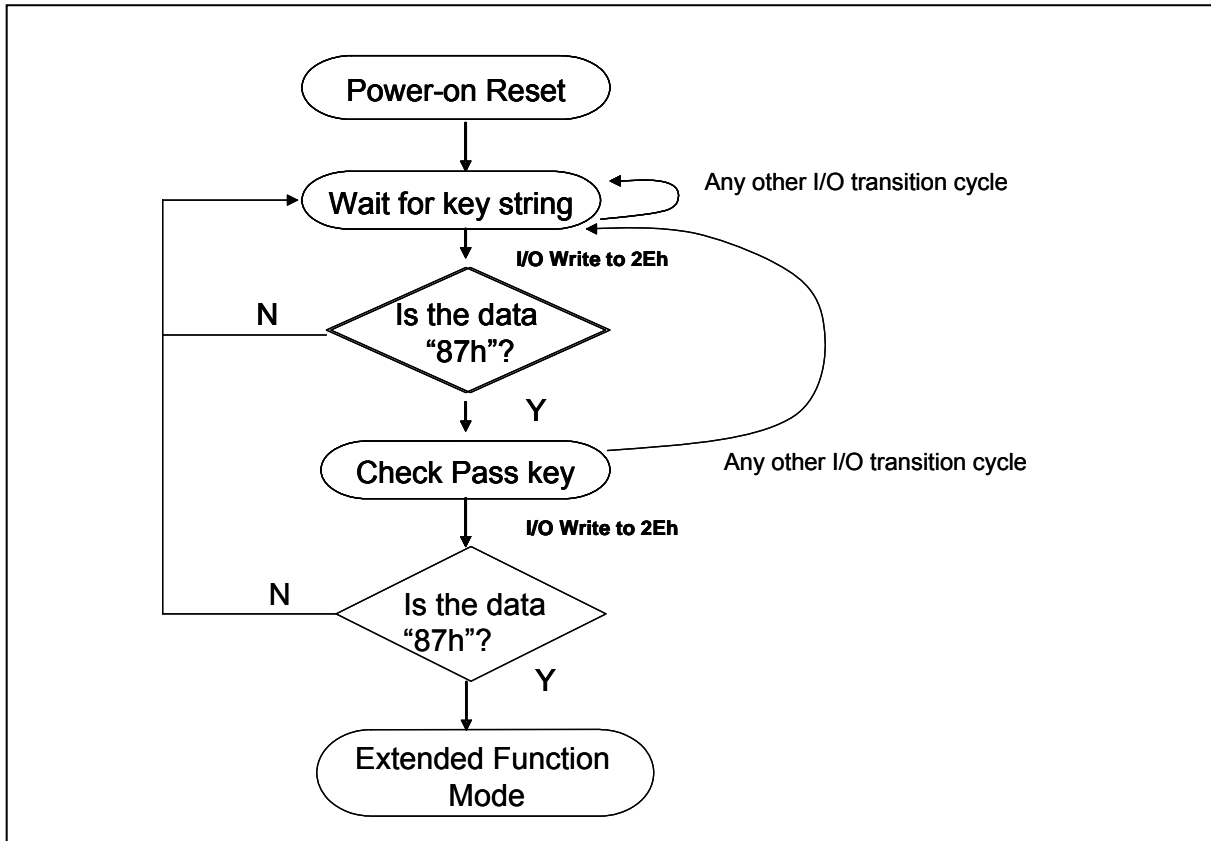

To program the W83627DHG configuration registers, the following configuration procedures must be followed in sequence:

- (1). Enter the Extended Function Mode.
- (2). Configure the configuration registers.
- (3). Exit the Extended Function Mode.

### 6.1.1 Enter the Extended Function Mode

To place the chip into the Extended Function Mode, two successive writes of 0x87 must be applied to Extended Function Enable Registers (EFERs, i.e. 2Eh or 4Eh).

### 6.1.2 Configure the Configuration Registers

The chip selects the Logical Device and activates the desired Logical Devices through Extended Function Index Register (EFIR) and Extended Function Data Register (EFDR). The EFIR is located at the same address as the EFER, and the EFDR is located at address (EFIR+1).

First, write the Logical Device Number (i.e. 0x07) to the EFIR and then write the number of the desired Logical Device to the EFDR. If accessing the Chip (Global) Control Registers, this step is not required.

Secondly, write the address of the desired configuration register within the Logical Device to the EFIR and then write (or read) the desired configuration register through the EFDR.



### 6.1.3 Exit the Extended Function Mode

To exit the Extended Function Mode, writing 0xAA to the EFER is required. Once the chip exits the Extended Function Mode, it is in the normal running mode and is ready to enter the configuration mode.

### 6.1.4 Software Programming Example

The following example is written in Intel 8086 assembly language. It assumes that the EFER is located at 2Eh, so the EFIR is located at 2Eh and the EFDR is located at 2Fh. If the HEFRAS (CR26 bit 6) is set, 2Eh can be directly replaced by 4Eh and 2Fh replaced by 4Fh.

```

;-----
; Enter the Extended Function Mode
;-----
MOVDX, 2EH
MOV    AL, 87H
OUT DX, AL
OUT DX, AL
;-----
; Configure Logical Device 1, Configuration Register CRF0
;-----
MOVDX, 2EH
MOVAL, 07H
OUT DX, AL      ; point to Logical Device Number Reg.
MOVDX, 2FH
MOVAL, 01H
OUT DX, AL      ; select Logical Device 1
;
MOVDX, 2EH
MOVAL, F0H
OUT DX, AL      ; select CRF0
MOVDX, 2FH
MOV    AL, 3CH
OUT DX, AL      ; update CRF0 with value 3CH
;-----
; Exit the Extended Function Mode
;-----
MOVDX, 2EH
MOV    AL, AAH
OUT DX, AL

```

**Chip (Global) Control Registers**

INDEX	R/W	DEFAULT VALUE	DESCRIPTION
02h	Write Only		Software Reset
07h	R/W	00h	Logical Device
20h	Read Only	A0h	Chip ID, MSB
21h	Read Only	2xh	Chip ID, LSB
22h	R/W	FFh	Device Power Down
23h	R/W	00h	Immediate Power Down
24h	R/W	0100_0ss0b	Global Option
25h	R/W	00h	Interface Tri-state Enable
26h	R/W	0s000000b	Global Option
27h	Reserved		
28h	R/W	50h	Global Option
29h	R/W	00h	Multi-function Pin Selection
2Ah	R/W	00h	SPI Configuration
2Bh	Reserved		
2Ch	R/W	E2h	Multi-function Pin Selection
2Dh	R/W	21h	Multi-function Pin Selection
2Eh	R/W	00h	Reserved
2Fh	R/W	00h	Reserved

S: Strapping; x: chip version.



## 7. HARDWARE MONITOR

### 7.1 General Description

The W83627DHG monitors several critical parameters in PC hardware, including power supply voltages, fan speeds, and temperatures, all of which are very important for a high-end computer system to work stably and properly.

The W83627DHG can simultaneously monitor all of the following inputs:

- Nine analog voltage inputs (four intrinsic monitor VBAT, 3VSB, 3VCC and AVCC power; five externally monitored power)
- Five fan tachometer inputs
- Three remote temperatures, by thermistor or from the CPU thermal-diode output(voltage or Current Mode)
- One case-open detection signal.

These inputs are converted to digital values using a built-in, eight-bit analog-to-digital converter (ADC).

In response to these inputs, the W83627DHG can generate the following outputs:

- Four PWM (pulse width modulation) or DC fan outputs for the fan speed control
- Beep tone output for warnings
- SMI#
- OVT# signals for system protection events

The W83627DHG provides hardware access to all monitored parameters through the LPC or I<sup>2</sup>C interface and software access through application software, such as Winbond's Hardware Doctor™, or BIOS. In addition, the W83627DHG can generate pop-up warnings or beep tones when a parameter goes outside of a user-specified range.

The rest of this section introduces the various features of the W83627DHG hardware-monitor capability. These features are divided into the following sections:

- Access Interfaces
- Analog Inputs
- Fan Speed Measurement and Control
- Smart Fan Control
- SMI# interrupt mode
- OVT# interrupt mode
- Registers and Value RAM

### 7.2 Access Interfaces

The W83627DHG provides two interfaces, LPC and I<sup>2</sup>C, for the microprocessor to read or write the internal registers of the hardware monitor.





**7.2.1 LPC Interface**

This interface uses the LPC bus to access the index and data ports. These two ports are located at the 16-bit port specified in CR60 and CR61, plus 5h and 6h, respectively. If the 16-bit port value is 290h, so the default index and data port addresses are 295h and 296h, respectively. The structure of the internal registers is shown in the following figure.

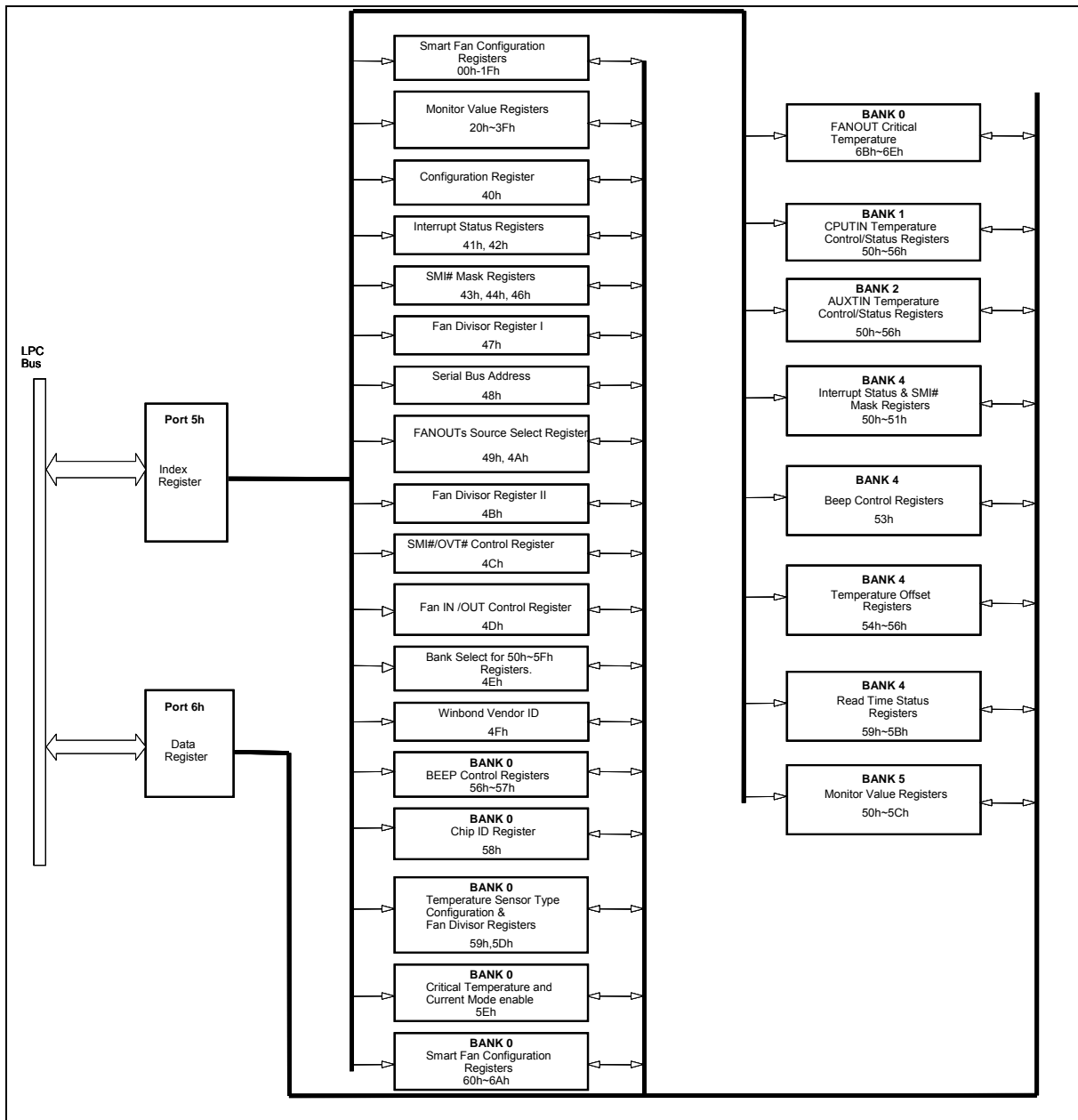



7.2.2 I<sup>2</sup>C interface

This interface uses the I<sup>2</sup>C Serial Bus to access the internal registers. The W83627DHG has a programmable serial-bus address that is controlled by index 48h.

The two timing diagrams below illustrate how to use the I<sup>2</sup>C interface to write to an internal register and how to read the value in an internal register, respectively.

(a) Serial bus write to internal address register followed by the data byte

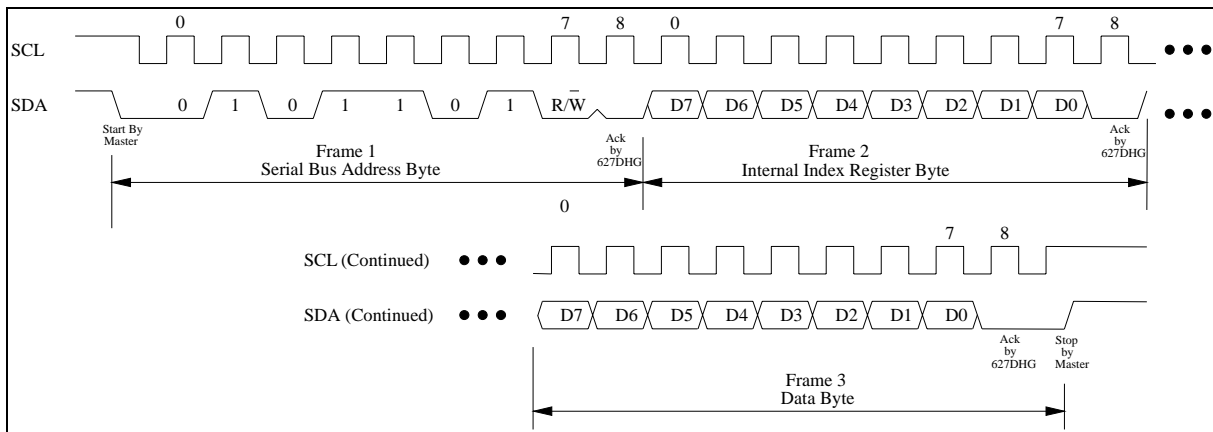

(b) Serial bus read from a register

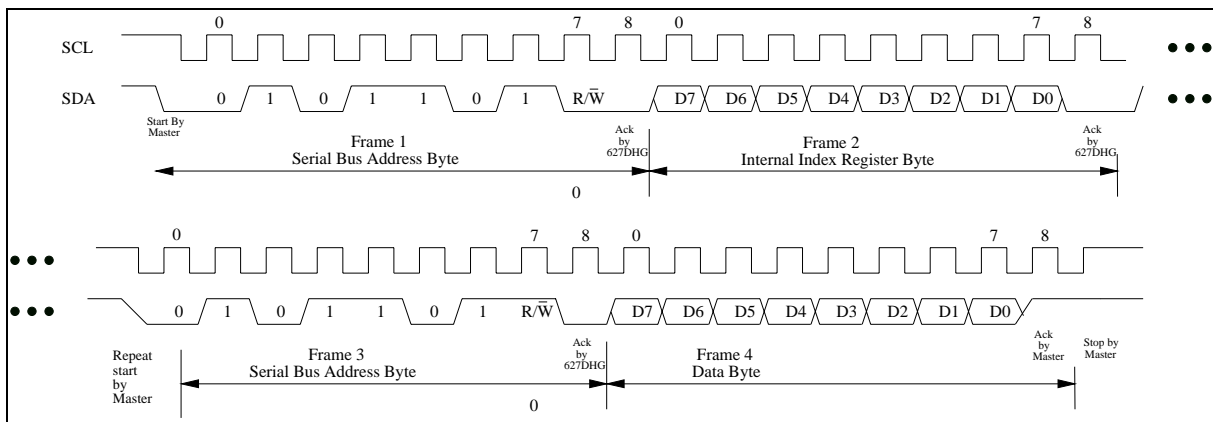



### 7.3 Analog Inputs

The maximum input voltage on analog pins is 2.048 V because the 8-bit ADC has an 8-mV LSB. Usually, the voltage ports of CPU Vcore (pin 100), battery (pin 74), 3VSB (pin 61), 3VCC (pin 12), and AVCC (pin 95) can be directly connected to their respective analog pins, as illustrated in the figure below.

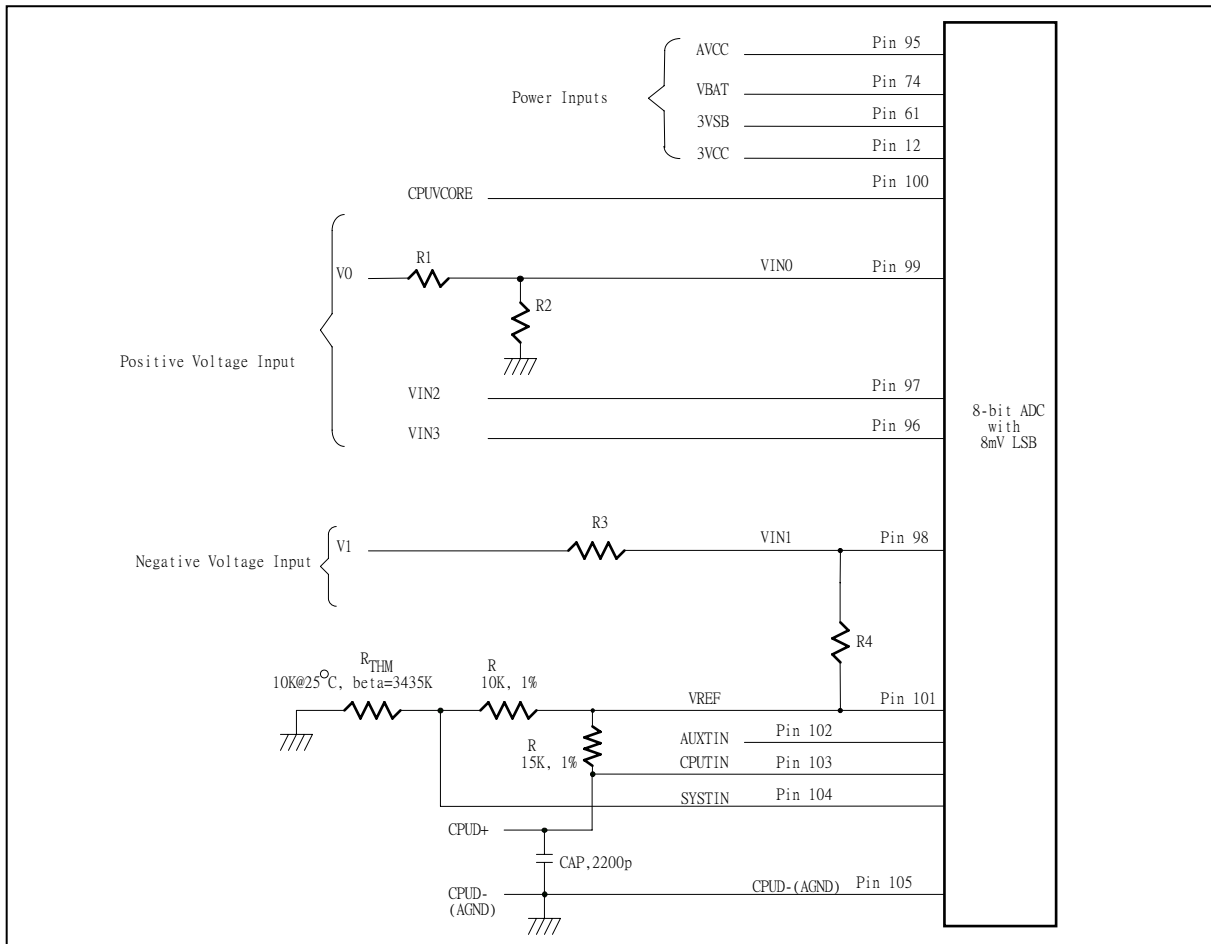

As illustrated in the figure above, other connections may require some external circuits. The rest of this section provides more information about voltages outside the range of the 8-bit ADC, CPU Vcore voltage detection, and temperature sensing

#### 7.3.1 Voltages Over 2.048 V or Less Than 0 V

Input voltages greater than 2.048 V should be reduced by external resistors to keep the input voltages in the proper range. For example, input voltage  $V_0$  (+12 V) should be reduced before it is connected to VIN0 according to the following equation:

$$VIN0 = V_0 \times \frac{R_2}{R_1 + R_2}$$



R1 and R2 can be set to 56 KΩ and 10 KΩ, respectively, to reduce V<sub>0</sub> from +12 V to less than 2.048 V.

The W83627DHG uses the same approach. Pins 12 and 95 provide two functions. One, these pins are connected to VCC at +3.3 V to supply internal (digital / analog) power to the W83627DHG. Two, these pins monitor VCC. The W83627DHG has two internal, 34-KΩ serial resistors that reduce the ADC-input voltage to 1.65 V.

$$V_{in} = VCC \times \frac{34K\Omega}{34K\Omega + 34K\Omega} \cong 1.65V, \text{ where } VCC \text{ is set to } 3.3V$$

Pin 61 is implemented likewise to monitor its +3.3 V stand-by power supply.

Negative voltages are handled similarly, though the equation looks a little more complicated. For example, negative voltage V<sub>1</sub> (-12V) can be reduced according to the following equation:

$$VIN1 = (V_1 - 2.048) \times \frac{R_4}{R_3 + R_4} + 2.048, \text{ where } V_1 = -12$$

R3 and R4 can be set to 232 KΩ and 10 KΩ, respectively, to reduce negative input voltage V<sub>1</sub> from -12 V to less than 2.048 V.

Both of these solutions are illustrated in the figure above.

### 7.3.2 Voltage Detection

The data format for voltage detection is an eight-bit value, and each unit represents an interval of 8 mV.

$$\text{Detected Voltage} = \text{Reading} * 0.008 \text{ V}$$

If the source voltage was reduced, the detected voltage value may have to be scaled up accordingly.

### 7.3.3 Temperature Sensing

The data format for sensor SYSTIN is 8-bit, two's-complement, and the data format for sensors CPUTIN and AUXIN is 9-bit, two's-complement. This is illustrated in the table below.

TEMPERATURE	8-BIT DIGITAL OUTPUT		9-BIT DIGITAL OUTPUT	
	8-BIT BINARY	8-BIT HEX	9-BIT BINARY	9-BIT HEX
+125°C	0111,1101	7Dh	0,1111,1010	0FAh
+25°C	0001,1001	19h	0,0011,0010	032h
+1°C	0000,0001	01h	0,0000,0010	002h
+0.5°C	-	-	0,0000,0001	001h
+0°C	0000,0000	00h	0,0000,0000	000h
-0.5°C	-	-	1,1111,1111	1FFh
-1°C	1111,1111	FFh	1,1111,1110	1FFh
-25°C	1110,0111	E7h	1,1100,1110	1CEh
-55°C	1100,1001	C9h	1,1001,0010	192h



Eight-bit temperature data is read from Index[27h]. For nine-bit temperature data, the 8 MSB are read from Bank1 / Bank2 Index[50h], and the LSB is read from Bank1 / Bank2 Index[51h], bit 7. There are two sources of temperature data: external thermistors or thermal diodes.

### 7.3.3.1. Monitor Temperature From Thermistor

External thermistors should have a  $\beta$  value of 3435K and a resistance of 10 K $\Omega$  at 25°C. As illustrated in the schematic below, the thermistor is connected in series with a 10-K $\Omega$  resistor and then connects to VREF (pin 101).

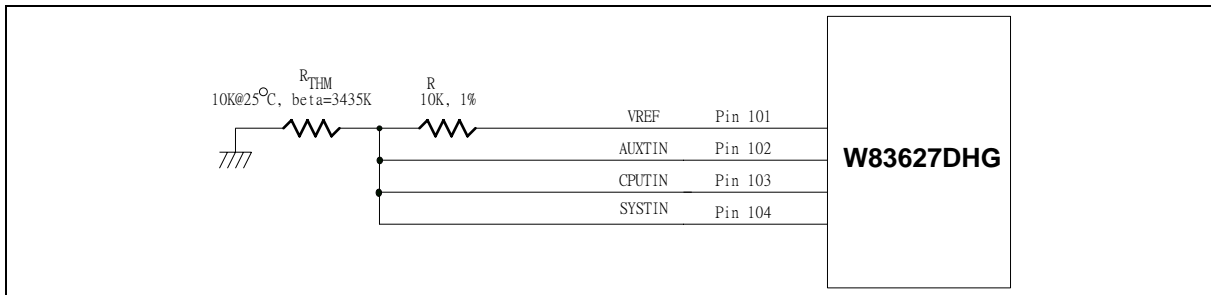

### 7.3.3.2. Monitor Temperature from Thermal Diode (Voltage Mode)

The thermal diode D- pin is connected to CPUD-(pin 105), and the D+ pin is connected to the temperature sensor pin in the W83627DHG. A 15-K $\Omega$  resistor is connected to VREF to supply the bias current for the diode, and the 2200-pF, bypass capacitor is added to filter high-frequency noise.

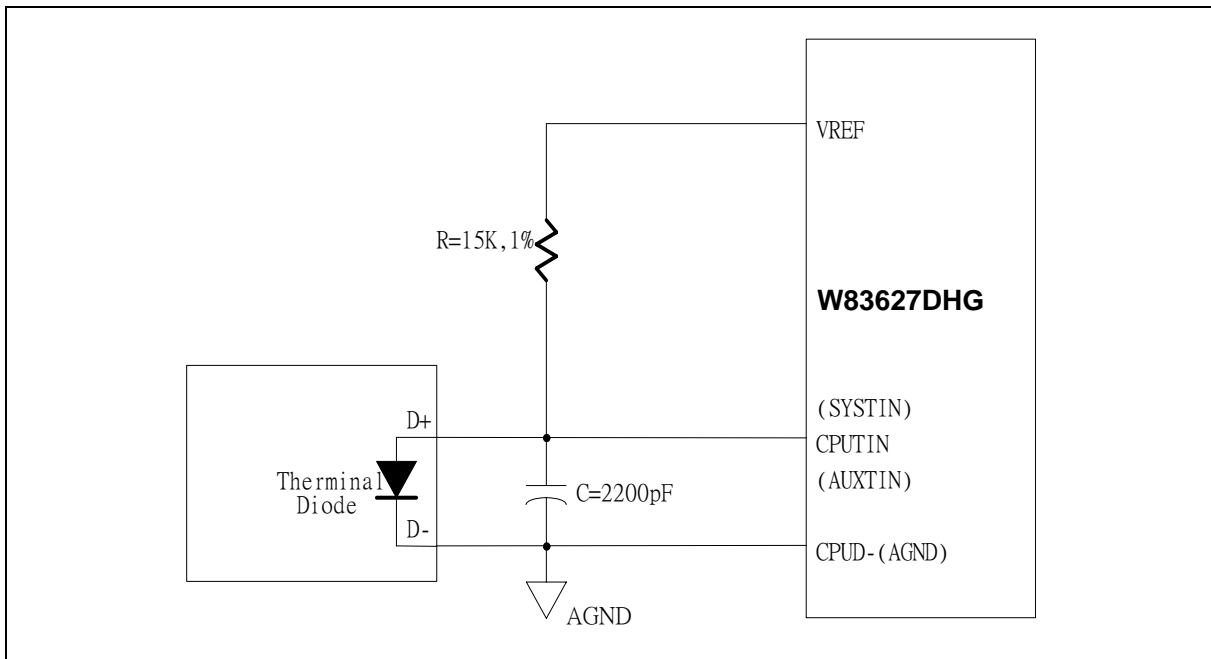



### 7.3.3.3. Monitor Temperature from Thermal Diode (Current Mode)

The W83627DHG can also sense the diode temperature through Current Mode and the circuit is shown in the following figure.

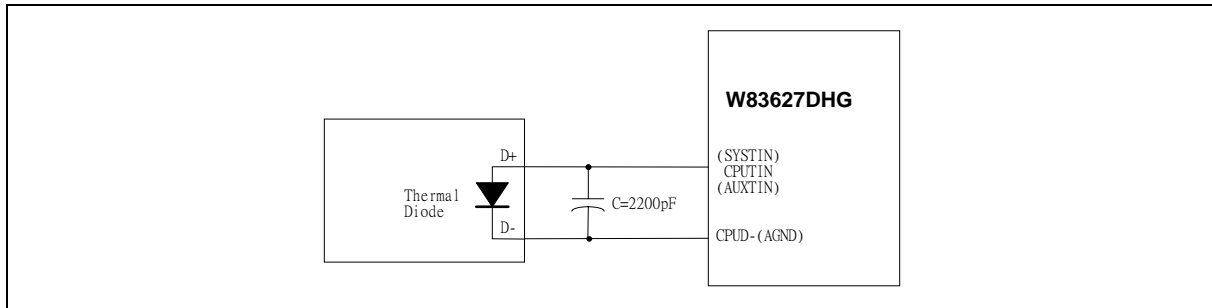

The pin of processor D- is connected to CPUD-(pin 105) and the pin D+ is connected to temperature sensor pin in the W83627DHG. A bypass capacitor C=2200pF should be added to filter the high frequency noise.

## 7.4 SST Command Summary

The W83627DHG is equipped with a built-in voltage and temperature sensor which uses the Simple Serial Transport (SST) interface. The sensor provides a means for an analog signal to travel over a digital bus enabling remote voltage and temperature sensing in areas previously not monitored in the PC.

SST is a self-clocked, one-wire bus for data transfer. The bus requires no additional control lines. In addition, SST also includes variable data transfer rate established with every message. Therefore, it is comparatively flexible. The W83627DHG has a programmable SST address defined at Logical Device C CR[F1h]. The default address is 0x48h which is within the range of 0x48h-0x4ah defined in the SST specification.

### 7.4.1 Command Summary

The W83627DHG supports SST commands as shown in the following table:

COMMAND	DESCRIPTION
GetIntTemp()	Returns the 2-byte temperature data values for pin SYSTIN(Pin 104)
GetExtTemp()	Returns the 2-byte temperature data values for pin CPUTIN(Pin 103)
GetAllTemps()	Returns the 4-byte temperature data values for both SYSTIN and CPUTIN
GetVolt12V()	Returns the 2-byte voltage data values for pin VIN0 (Pin 99). This pin should be connected to +12V power through scaling resistors Refer to 7.4.2.2
GetVolt5V()	Returns the 2-byte voltage data values for pin VIN1 (Pin 98). This pin should be connected to +5V power through scaling resistors Refer to 7.4.2.2
GetVolt3p3V()	Returns the 2-byte voltage data values for pin 3VCC (Pin 12, 28, 48). This pin should be connected to +3.3V power directly Refer to 7.4.2.2



Command Summary, continued.

COMMAND	DESCRIPTION
GetVolt2p5V()	Returns the 2-byte voltage data values for pin VIN2 (Pin 97). This pin should be connected to +2.5V power through scaling resistors. Refer to 7.4.2.2
GetVoltVccp()	Returns the 2-byte voltage data values of CPUVCORE (Pin 100). This pin should be connected to CPU power supply directly. The CPU power supply voltage must not be higher than <b>2.048</b> volt
GetAllVoltages()	Returns a 10-byte voltage data value containing all the above listed five (5) voltages

## 7.4.2 Combination Sensor Data Format

### 7.4.2.1. Temperature Data Format

The W83627DHG temperature data format of both CPUTIN and SYSTIN is 16-bit two's-complement binary value. It represents multiple of 1/64°C in the temperature reading.

Table 1 shows some typical temperature values in 16-bit two's complement format.

Table 1 Typical Temperature Values

TEMPERATURE	16-BIT DIGITAL OUTPUT (TWO'S COMPLEMENT)	
	16-BIT BINARY	16-BIT HEX
+80°C	0001 0100 0000 0000	1400h
+79.5°C	0001 0011 1110 0000	13E0h
+1°C	0000 0000 0100 0000	0010h
+0°C	0000 0000 0000 0000	0000h
-1°C	1111 1111 1100 0000	FFC0h
-5°C	1111 1110 1100 0000	FEC0h

### 7.4.2.2. Voltage Data Format

The W83627DHG can return five (5) voltage values through the SST interface. The voltage data format is 16-bit two's-complement binary. The relation between the 2-byte data and the monitored voltage is listed below:

- 1) CPUVCORE (pin 100) = Decimal[2-byte data by GetVoltVccp() ] / 1024 volts
- 2) 3VCC (pin 12) = Decimal[2-byte data by GetVolt3p3V()] / 1024 volts
- 3) "+12V" = Decimal[2-byte data by GetVolt12V()] / 1024 / ((R1+R2) / R2) volts

VIN0 (pin 99) is connected as shown below:.

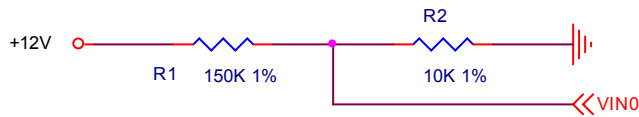

4) “+5VCC” = Decimal[2-byte data by GetVolt5V()] / 1024 / ((R3+R4) / R4) volts

VIN1 (pin 98) is connected as shown below:

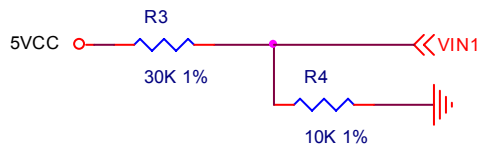

5) “+2.5V” = Decimal[2-byte data by GetVolt2p5V()] / 1024 / ((R5+R6) / R6) volts

VIN2 (pin 97) is connected as shown below:

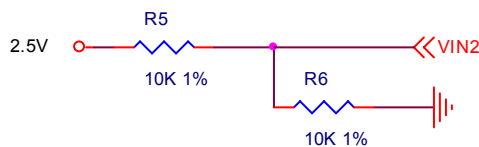

## 7.5 PECE

PECE (Platform Environment Control Interface) is a proprietary derivation of SST. It is one of the temperature sensing methods that the W83627DHG supports. With a bandwidth ranging from 2 kbps to 2 Mbps, the PECE uses a single wire – no additional control lines needed – for self-clocking and data transfer. By interfacing to the Digital Thermal Sensor on the Intel® CPU, PECE reports a negative temperature value relative to the processor’s temperature at which the thermal control circuit (TCC) is activated.

To enable the PECE functionalities of the W83627DHG, BIOS/Software should follow the steps below:

1. Program Logical Device C, CR[E8h] bit (1..0) for PECE speed selection to meet the bit timing limits of CPU with PECE function. We recommend this bit is set to “11” for better stability.
2. Program Logical Device C, CR[E5h] bit (7..4) for each PECE Agent to match the number of domains in the processors. Setting to “1” enables the W83627DHG to issue GetTemp(0) and GetTemp(1) commands to access the PECE temperatures of domain 0 and domain 1. Setting to “0” enables the W83627DHG to issue GetTemp(0) command for domain 0.
3. Program Logical Device C, CR[E0] bit (3..0) for each PECE Agent. Setting to “1” returns the PECE temperature of domain 1 to the temperature reading register. Setting to “0” returns the PECE temperature of domain 0 to the temperature reading register. If CR[E5] bit 1 is set to “1”, the higher PECE temperature of domain 0 and domain 1 is returned to the temperature reading register. See the example below for more details about the temperature reading register(s)
4. Program Logical Device C, CR[E0h] bit (7..4) for each PECE Agent. Setting to “1” enables the W83627DHG to access the agent. The power-on default is disabled. After an agent is enabled, the W83627DHG issues PING and GetTemp commands to obtain the PECE temperature





5. Since the PECE temperature is a relative value, the W83627DHG provides registers for each PECE Agent to convert the relative value to a more traditional "absolute" format. The *TBase registers* (Logical Device C, CR[E1h]~CR[E4h]) store the "base" temperature. By means of BIOS/software, the desired base temperature can be written to these registers. Important: the value must be positive. Otherwise abnormal temperature responses will take place. Here is an example on how to obtain TBase value:

(1). Use a digital thermometer on the surface of the PECE processor to measure the processor body temperature.

(2). Power up the system the PECE processor. Run the processor to 100% loading.

(3). After the system is stable, read the PECE reading from Logical Device C, CR[FEh] and CR[FFh] and record the value of digital thermometer.

(4). Calculate TBase. For example, if PECE = -10 and the digital thermometer is 50°C, then TBase could be set to 60°C. ( 60 – 10 = 50 ).

6. There are two temperature reading registers in the W83627DHG: CPUTIN (Bank1 Index 50h & 51h) and AUCTIN (Bank2 Index 50h & 51h). The source of the CPUTIN value is determined by the value programmed into the *CPUFANOUT0 monitor Temperature source select register* (Hardware Monitor Device, Bank 0, Index 49h, bits (2..0)). The source of AUCTIN value is determined by the value programmed into the *AUXFANOUT monitor Temperature source select register* (Hardware Monitor Device, Bank 0, Index 49h, bits(6..4))

7. The temperature values in CPUTIN and AUCTIN are:

CPUTIN = (TBase) + (PECE Agent relative temperature)

AUCTIN = (TBase) + (PECE Agent relative temperature)

Example:

If the PECE relative temperature of agent 1 is -10; TBase is set to 72°C, and Bank0 Index 49h selects PECE Agent 1 as the temperature source, the reported temperature will be 62°C (-10 + 72).

**Please be noted that when the temperature source is selected as PECE, the CPUTIN or AUCTIN register reading does not reflect the actual temperature of processor.**

8. In addition, the W83627DHG provides a PECEISB pin that can be connected to a PECE host (e.g. chipset), so the W83627DHG becomes a bridge between that PECE host and the PECE client (e.g. CPU with PECE function). The bridge can pass the CPU PECE signals by programming Configure Register at Logical Device C, CR[E5h] Bit 0. An illustration is provided below (ICH8 is the alternative PECE host).

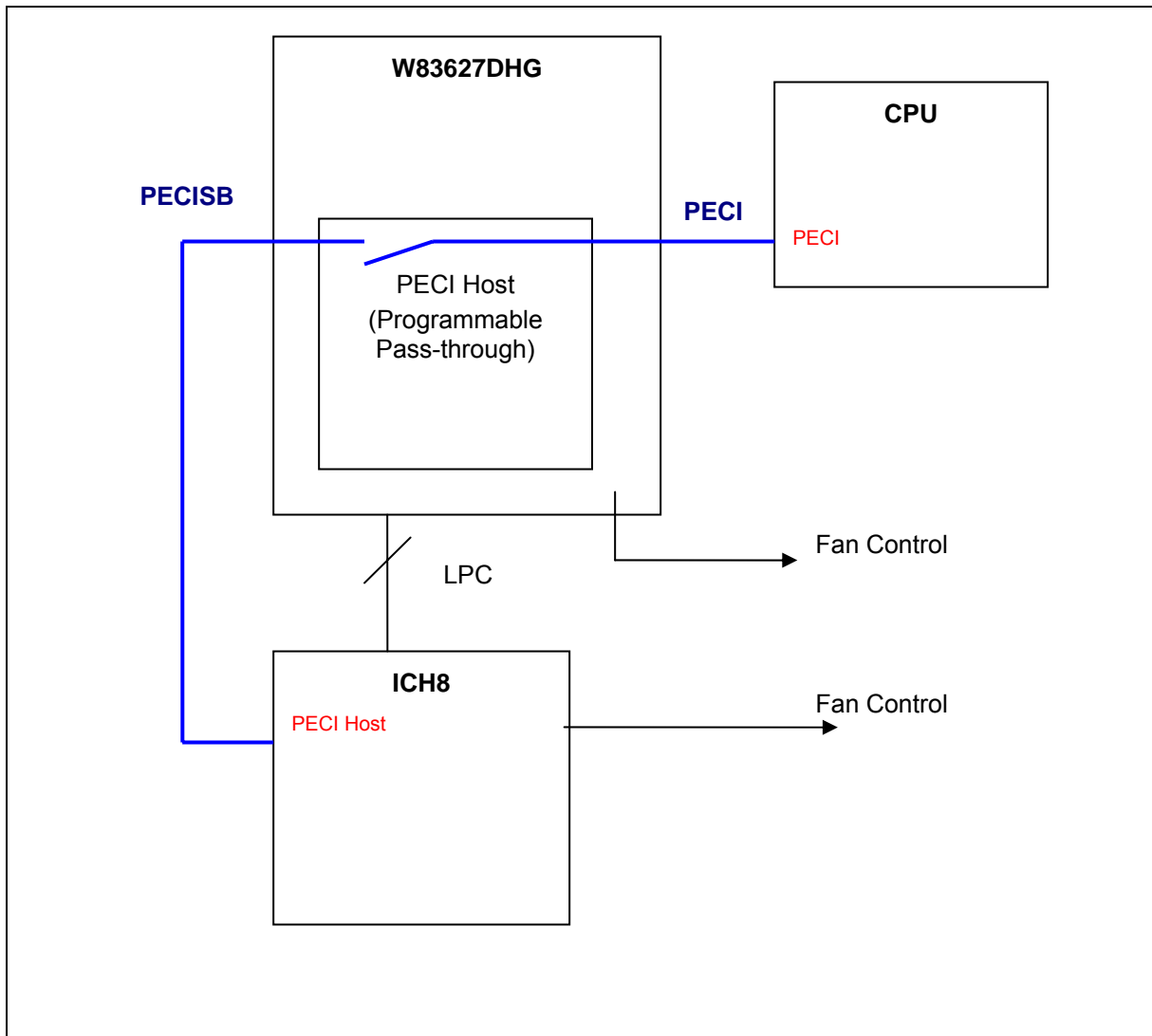

9. A warning flag register at Logical Device C, CR[E8h] bit (7..4) is designed for each PECI Agent to report whether the W83627DHG (PECI host) detects the PECI client or not and whether the PECI client returns invalid FCS values from the polling for three successive times.



## 7.6 Fan Speed Measurement and Control

This section is divided into two parts, one to measure the speed and one to control the speed.

### 7.6.1 Fan Speed Measurement

The W83627DHG can measure fan speed for fans equipped with tachometer outputs. The tachometer signals should be set to TTL-level, and the maximum input voltage cannot exceed +3.3 V. If the tachometer signal exceeds +3.3 V, an external trimming circuit should be added to reduce the voltage accordingly.

The fan speed counter is read from Bank0 Index 28h, 29h, 2Ah, and 3Fh and Bank5 Index 53h. The fan speed can then be evaluated by the following equation:

$$RPM = \frac{1.35 \times 10^6}{Count \times Divisor}$$

The default divisor is 2 and is specified at Bank0 Index 47h, bits 7 ~ 4; Index 4Bh, bits 7 ~ 6; Index 4Ch, bit 7; Index 59h, bit 7 and bits 3 ~ 2; and Index 5Dh, bits 5 ~ 7. There are three bits for each divisor, and the corresponding divisor is listed in the table below.

BIT 2	BIT 1	BIT 0	FAN DIVISOR	BIT 2	BIT 1	BIT 0	FAN DIVISOR
0	0	0	1	1	0	0	16
0	0	1	2	1	0	1	32
0	1	0	4	1	1	0	64
0	1	1	8	1	1	1	128

The following table provides some examples of the relationship between divisor, RPM, and count.

DIVISOR	NOMINAL RPM	TIME PER REVOLUTION	COUNTS	70% RPM	TIME FOR 70%
1	8800	6.82 ms	153	6160	9.84 ms
<b>2 (default)</b>	4400	13.64 ms	153	3080	19.48 ms
4	2200	27.27 ms	153	1540	38.96 ms
8	1100	54.54 ms	153	770	77.92 ms
16	550	109.08 ms	153	385	155.84 ms
32	275	218.16 ms	153	192	311.68 ms
64	137	436.32 ms	153	96	623.36 ms
128	68	872.64 ms	153	48	1246.72 ms



### 7.6.2 Fan Speed Control

The W83627DHG has four output pins for fan control, each of which offers PWM duty cycle and DC voltage to control the fan speed. The output type (PWM or DC) of each pin is configured by Bank0 Index 04h, bits 1 ~ 0; Index 12h, bit 0; and Index 62h, bit 6.

For PWM, the duty cycle is programmed by eight-bit registers at Bank0 Index 01h, Index 03h, Index 11h and Index 61h. The duty cycle can be calculated using the following equation:

$$\text{Duty cycle(\%)} = \frac{\text{Programmed 8-bit Register Value}}{255} \times 100\%$$

The default duty cycle is FFh, or 100%. The PWM clock frequency is programmed at Bank0 Index 00h, Index 02h, Index 10h and Index 60h.

For DC, the W83627DHG has a six bit digital-to-analog converter (DAC) that produces 0 to 3.3 Volts DC. The analog output is programmed at Bank0 Index 01h, Index 03h, Index 11h and Index 61h. The analog output can be calculated using the following equation:

$$\text{OUTPUT Voltage (V)} = \frac{\text{Programmed 6-bit Register Value}}{64} \times \text{AVCC}$$

The default value is 111111YY, or nearly 3.3 V, and Y is a reserved bit.



### 7.6.3 SMART FAN™ Control

The W83627DHG supports two SMART FAN™ I features—Thermal Cruise™ mode and Fan Speed Cruise™ mode—and SMART FAN™ III. Each of these is discussed in the following sections. When enabling SMART FAN™ I features, fan output starts from the previous setting in Bank0 Index 01h, Index 03h, Index 11h and Index 61h

There are four pairs of temperature sensors and fan outputs in SMART FAN™ I, it is illustrated in the figure below.

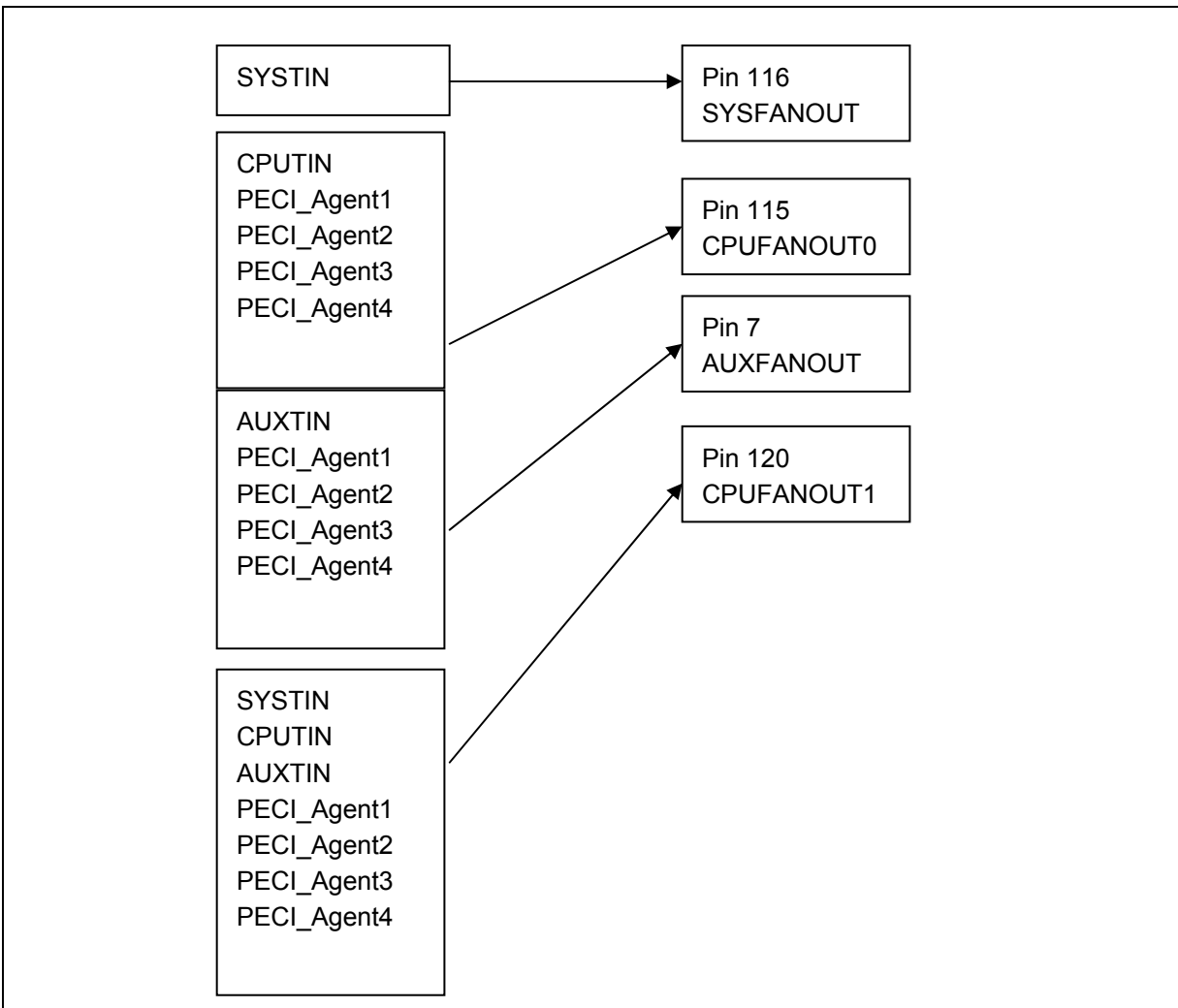

#### 7.6.3.1. Thermal Cruise™ Mode

Four pairs of temperature sensors and fan outputs in Thermal Cruise™ mode:

- SYSTIN and SYSFANOUT
- CPUFANOUT0 and the temperature sensor selected by Bank0 Index 49h, bits 2 ~ 0
- AUXFANOUT and the temperature sensor selected by Bank0 Index 49h, bits 6 ~ 4
- CPUFANOUT1 and the temperature sensor selected by Bank0 Index 4Ah, bits 7 ~ 5



Thermal Cruise™ mode controls the fan speed to keep the temperature in a specified range. First, this range is defined in BIOS by a temperature and the interval (e.g.,  $55\text{ °C} \pm 3\text{ °C}$ ). As long as the current temperature remains below the low end of this range (i.e.,  $52\text{ °C}$ ), the fan is off. Once the temperature exceeds the low end, the fan turns on at a speed defined in BIOS (e.g., 20% output). Thermal Cruise™ mode then controls the fan output according to the current temperature. Three conditions may occur:

- (1) If the temperature still exceeds the high end, fan output increases slowly. If the fan is operating at full speed but the temperature still exceeds the high end, a warning message is issued to protect the system.
- (2) If the temperature falls below the high end (i.e.,  $58\text{ °C}$ ) but remains above the low end (e.g.,  $52\text{ °C}$ ), fan output remains the same.
- (3) If the temperature falls below the low end (e.g.,  $52\text{ °C}$ ), fan output decreases slowly to zero or to a specified “stop value”. This stop value is enabled by Bank0 Index 12h, bits 3 ~ 5, and the value itself is specified in Bank0 Index 08h, Index 09h, Index 15h, and Index 64h. The fan remains at the stop value for the period of time defined in Bank0 Index 0Ch, Index 0Dh, Index 17h, and Index 66h.

In general, Thermal Cruise™ mode means

- if the current temperature is higher than the high end, increase the fan speed;
- if the current temperature is lower than the low end, decrease the fan speed;
- otherwise, keep the fan speed the same.

The following figures illustrate two examples of Thermal Cruise™ mode.

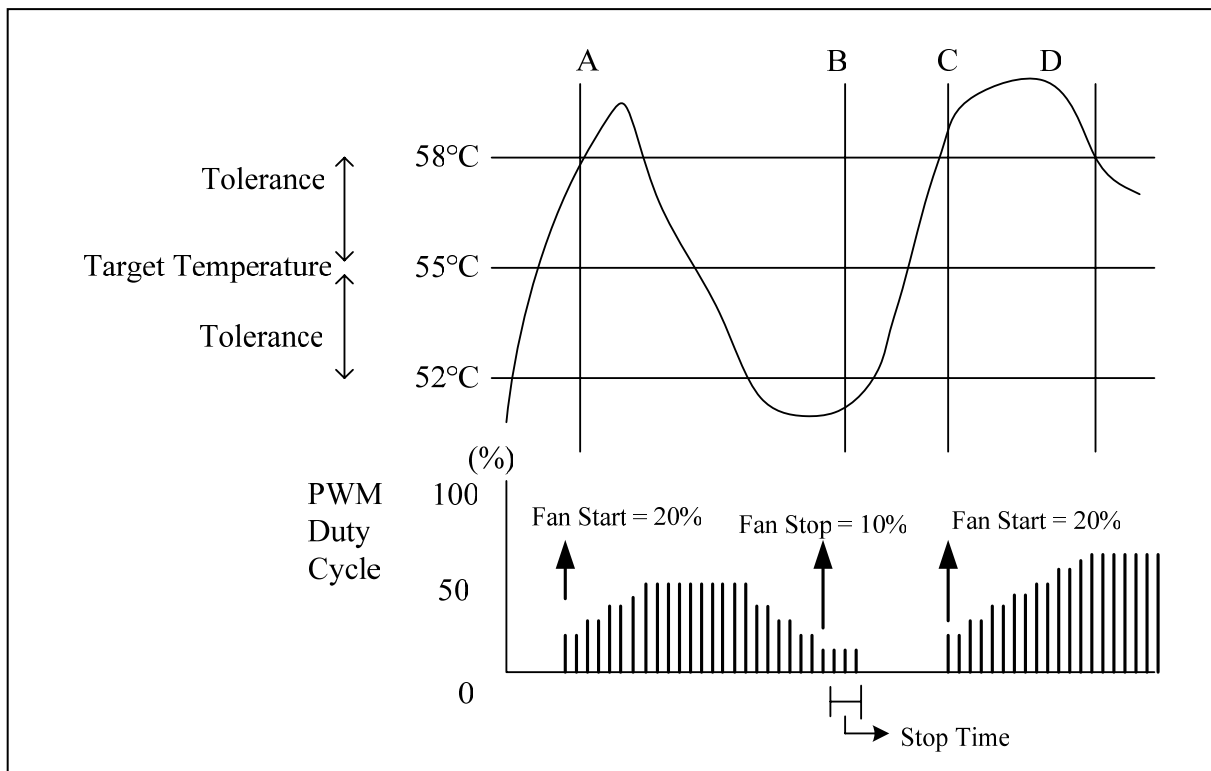

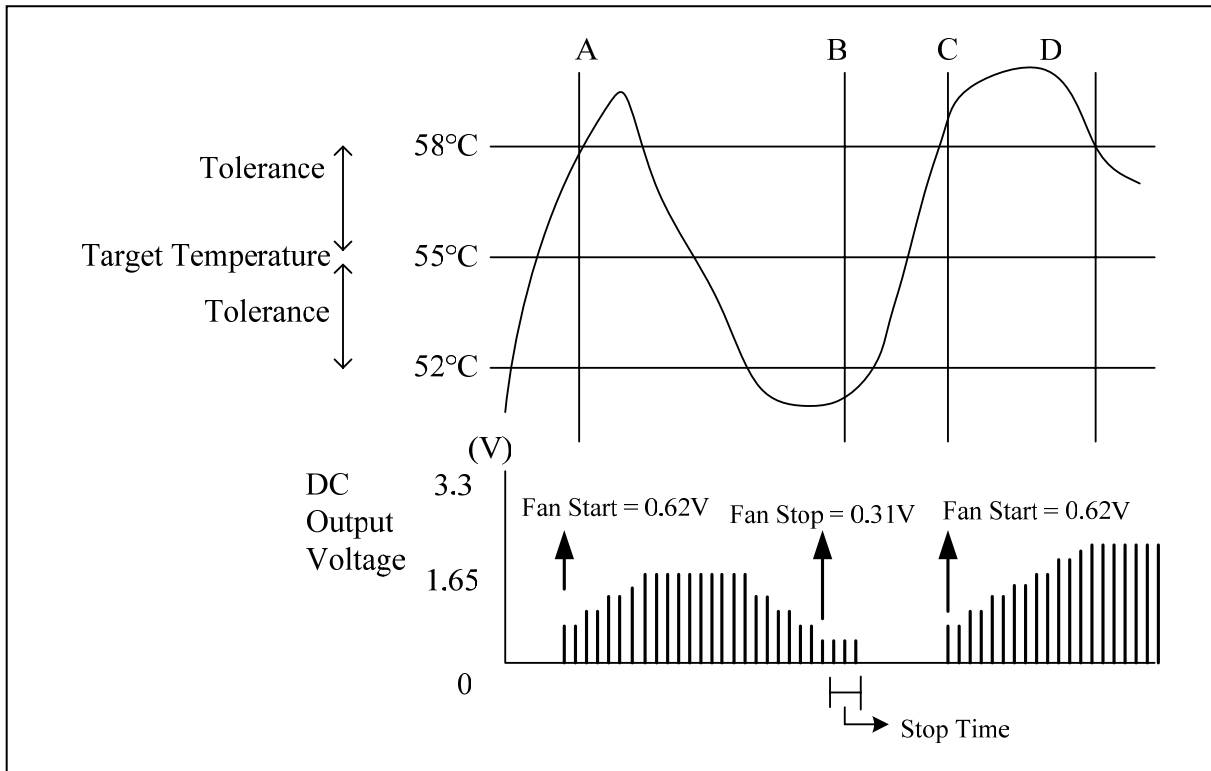

### 7.6.3.2. Fan Speed Cruise™ Mode

Four pairs of fan input sensors and fan outputs in Fan Speed Cruise™ mode.

- SYSFANIN and SYSFANOUT
- CPUFANIN0 and the temperature sensor selected by Bank0 Index 49h, bits 2 ~ 0
- AUXFANOUT and the temperature sensor selected by Bank0 Index 49h, bits 6 ~ 4
- CPUFANOUT1 and the temperature sensor selected by Bank0 Index 4Ah, bits 7 ~ 5

Fan Speed Cruise™ mode keeps the fan speed in a specified range. First, this range is defined in BIOS by a fan speed count (the amount of time between clock input signals, not the number of clock input signals in a period of time) and an interval (e.g.,  $160 \pm 10$ ). As long as the fan speed count is in the specified range, fan output remains the same. If the fan speed count is higher than the high end (e.g., 170), fan output increases to make the count lower. If the fan speed count is lower than the low end (e.g., 150), fan output decreases to make the count higher. One example is illustrated in this figure.

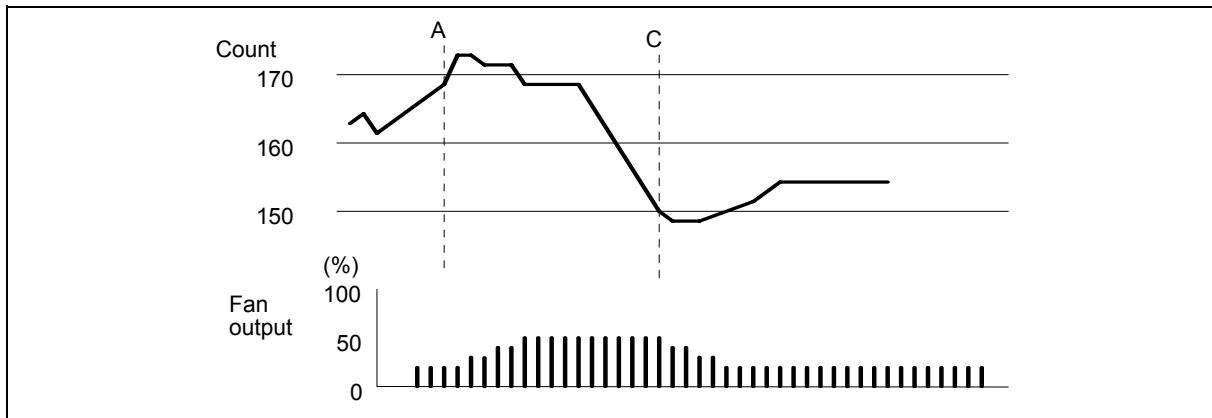

The following tables show current temperatures, fan output values and the relative control registers at Thermal Cruise™ and Fan Speed Cruise™ mode.

#### Display Registers - at SMART FAN™ I Mode

DESCRIPTION	REGISTER ADDRESS	REGISTER NAME	ATTRIBUTE	BIT DATA
Current CPU Temperature	Bank1 Index 50h ,51h	CPUTIN Temperature Sensor	Read only	8 MSB, 1°C bit 7, 0.5 °C
Current SYS Temperature	Bank 0 Index 27h	SYSTIN Temperature Sensor	Read only	8 MSB, 1°C
Current AUX Temperature	Bank2 Index 50h,51h	AUXTIN Temperature Sensor	Read only	8 MSB, 1°C bit 7, 0.5 °C
Current CPUFANOUT0 Output Value	Bank0 Index 03h	CPUFANOUT0 Output Value Select	80h / FFh by strapping	bits 7~0 CPUFANOUT0 Value
Current SYSFANOUT Output Value	Bank0 Index 01h	SYSFANOUT Output Value Select	FFh	bits 7~0 SYSFANOUT Value
Current AUXFANOUT Output Value	Bank0 Index 11h	AUXFANOUT Output Value Select	FFh	bits 7~0 AUXFANOUT Value
Current CPUFANOUT1 Output Value	Bank0 Index 61h	CPUFANOUT1 Output Value Select	80h / FFh by strapping	bits 7~0 CPUFANOUT1 Value



**Relative Registers - at Thermal Cruise™ Mode**

THERMAL-CRUISE™ MODE	TARGET TEMPERATURE	TOLERANCE	START-UP VALUE	STOP VALUE	KEEP MIN. FAN OUTPUT VALUE	STOP TIME	STEP-DOWN TIME	STEP-UP TIME
SYSFANOUT	Bank0, 05h	Bank0, 07h Bit0-3	Bank0, 0Ah	Bank0, 08h	Bank0, 12h, Bit5	Bank0, 0Ch	Bank0, 0Eh	Bank0, 0Fh
CPUFANOUT0	Bank0, 06h	Bank0, 07h, Bit4-7	Bank0, 0Bh	Bank0, 09h	Bank0, 12h, Bit4	Bank0, 0Dh		
AUXFANOUT	Bank0, 13h	Bank0, 14h, Bit0-3	Bank0, 16h	Bank0, 15h	Bank0, 12h, Bit3	Bank0, 17h		
CPUFANOUT1	Bank0, 63h	Bank0, 62h, Bit0-3	Bank0, 65h	Bank0, 64h	Bank0, 12h, Bit6	Bank0, 66h		

**Relative Registers-at Fan Speed Cruise™ Mode**

SPEED CRUISE™ MODE	TARGET-SPEED COUNT	TOLERANCE	KEEP MIN. FAN OUTPUT VALUE	STEP-DOWN TIME	STEP-UP TIME
SYSFANOUT	Bank0, Index 05h	Bank0, Index 07h, bits 0-3	Bank0, Index 12h, Bit5	Bank0, Index 0Eh	Bank0, Index 0Fh
CPUFANOUT0	Bank0, Index 06h	Bank0, Index 07h, bits 4-7	Bank0, Index 12h, Bit4		
AUXFANOUT	Bank0, Index 13h	Bank0, Index 14h, bits 0-3	Bank0, Index 12h, Bit3		
CPUFANOUT1	Bank0, Index 63h	Bank0, Index 62h, bits 0-3	Bank0, Index 12h, Bit6		



### 7.6.3.3. SMART FAN™ III

SMART FAN™ III controls the fan speed so that the temperature meets the target temperature set in BIOS or application software. There are only two pairs of fan outputs and temperature sensors in SMART FAN™ III mode.

- CPUFANOUT0 and the temperature sensor selected by Bank0 Index 49h, bits 2 ~ 0
- CPUFANOUT1 and the temperature sensor selected by Bank0 Index 4Ah, bits 7 ~ 5

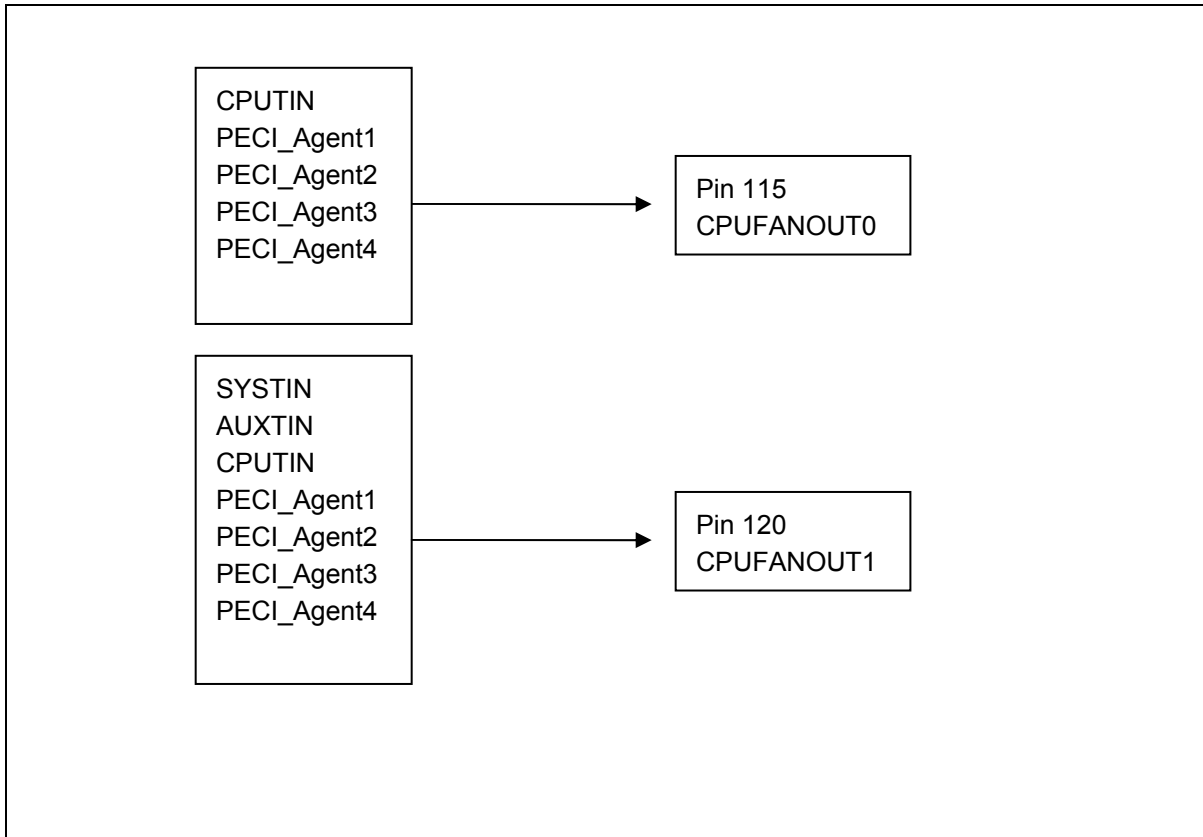

The algorithm is as follows:

- (1) The target temperature, temperature tolerance, maximum and minimum fan outputs and step are set.
- (2) The following figure shows the initial conditions. If the current temperature is within (Target Temperature  $\pm$  Temperature Tolerance), the fan speed remains constant.

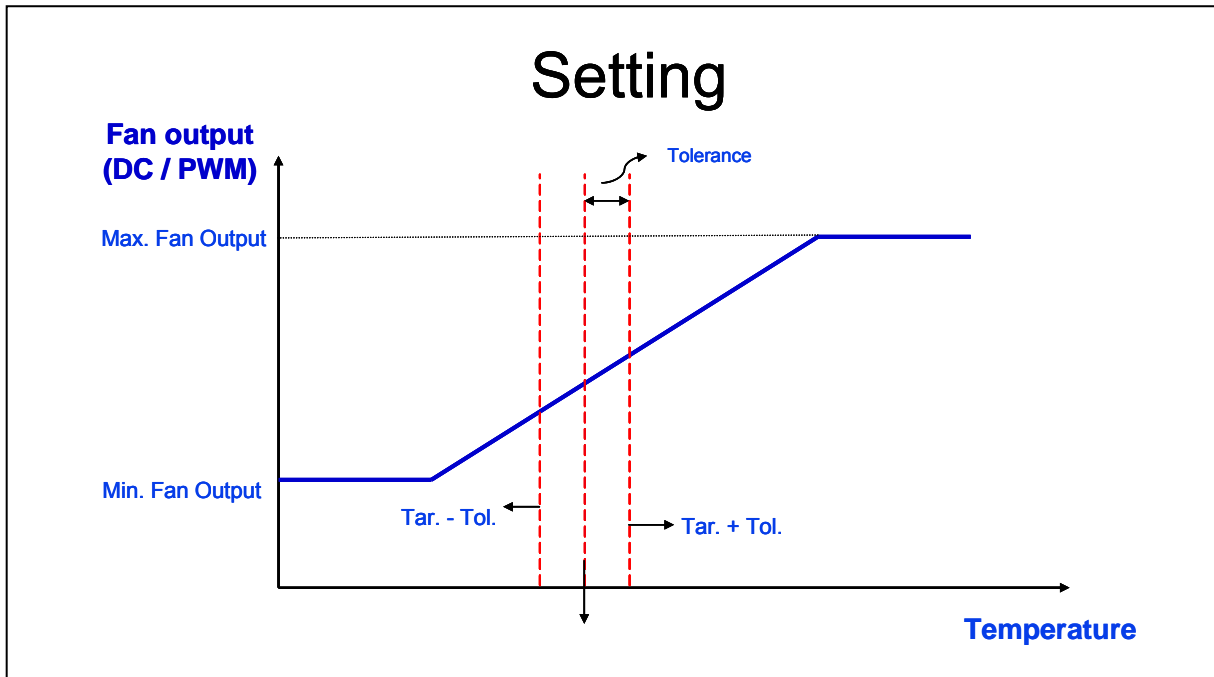

- (3) If the current temperature is higher than (Target Temperature + Temperature Tolerance), fan speed rises one step. The step is the value in the CPUFANOUT Output Value Select Register, Bank0 Index 03h or Index 61h. In addition, the target temperature shifts to (Target Temperature + Temperature Tolerance), creating a new target temperature, named Target Temperature 1 in this figure.

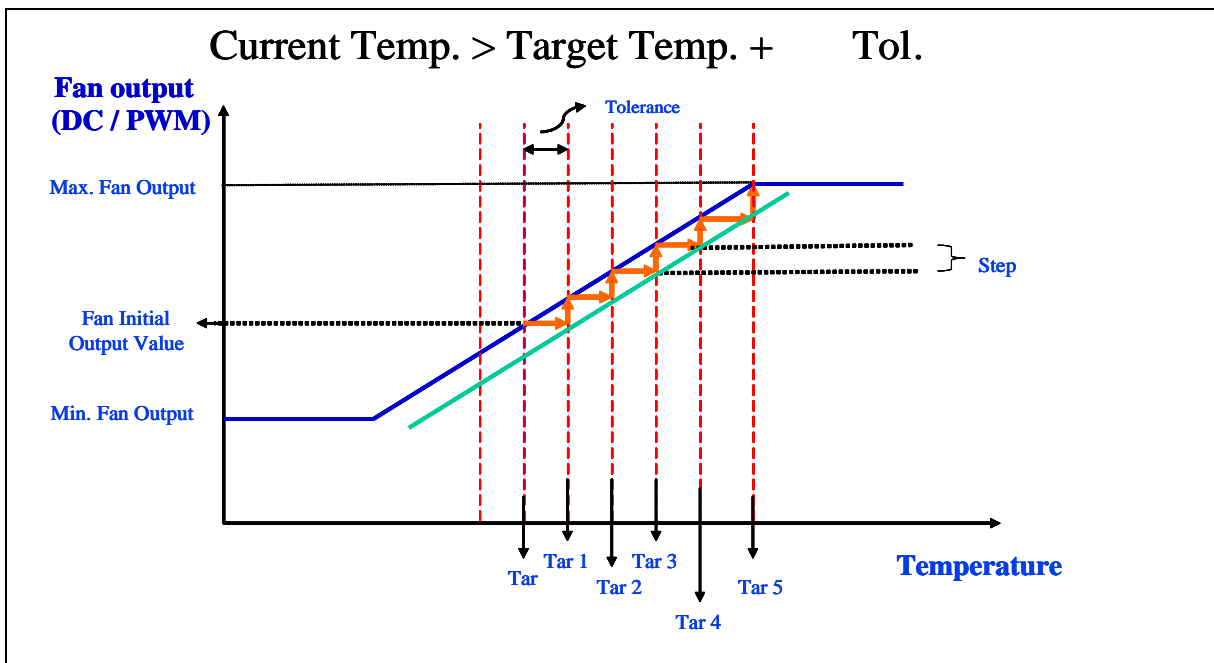



If the current temperature rises higher than (Target Temperature 1 + Temperature Tolerance), the fan speed rises one step again, and the target temperature shifts to (Target Temperature 1 + Temperature Tolerance), or Target Temperature 2. This process repeats whenever the current temperature is higher than (Target Temperature X ± Temperature Tolerance) or until the fan speed reaches its maximum speed.

- (4) If the current temperature falls below (Target Temperature – Temperature Tolerance), the fan speed falls one step. The step is the value in the CPUFANOUT Output Value Select Register, Bank0 Index 03h or Index 61h. In addition, the target temperature shifts to (Target Temperature – Temperature Tolerance), creating a new target temperature named Target Temperature 1. This is illustrated in the figure below.

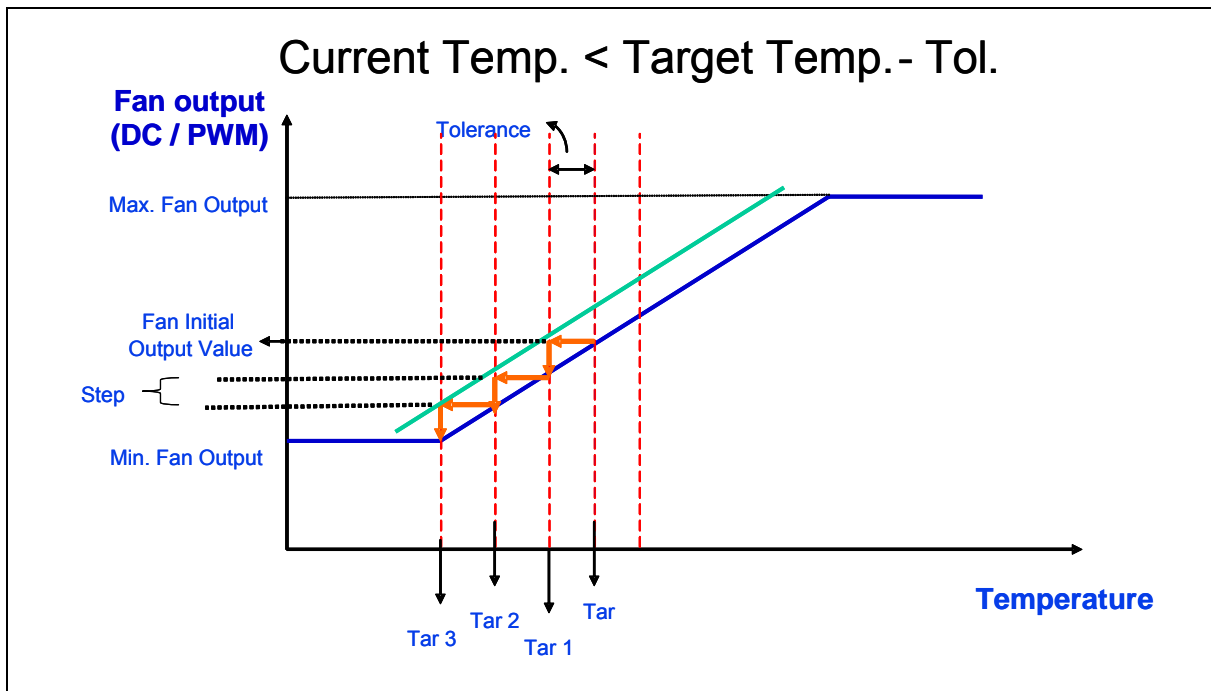

If the current temperature falls lower than (Target Temperature 1 – Temperature Tolerance), the fan speed is reduced one step again, and the target temperature shifts to (Target Temperature 1 – Temperature Tolerance), or Target Temperature 2. This process repeats whenever the current temperature is lower than (Target Temperature X – Temperature Tolerance) or until the fan speed reaches its minimum speed.

- (5) If the current temperature is always lower than (Target Temperature X – Temperature Tolerance), the fan speed decreases slowly to zero or to a specified stop value. The stop value is enabled by register Bank0 Index 12h, bit 4 and bit 6, and the stop value is specified in Bank0 Index 09h and Index 64h. The fan remains at the stop value for the period of time defined in Bank0 Index 0Dh and Index 66h.



The following tables show current temperatures, fan output values and the relative control registers at SMART FAN™ III mode.

**Display Register- at SMART FAN™ III Mode**

DESCRIPTION	REGISTER ADDRESS	REGISTER NAME	ATTRIBUTE	BIT DATA
Current CPU Temperature	Bank1 Index 50h ,51h	CPUTIN Temperature Sensor	Read only	8 MSB, 1°C bit 7, 0.5 °C
Current SYS Temperature	Bank 0 Index 27h	SYSTIN Temperature Sensor	Read only	8 MSB, 1°C
Current AUX Temperature	Bank2 Index 50h,51h	AUXTIN Temperature Sensor	Read only	8 MSB, 1°C bit 7, 0.5 °C
Current CPUFANOUT0 Output Value	Bank0 Index 03h	CPUFANOUT0 Output Value Select	80h / FFh by strapping	bits 7~0 CPUFANOUT0 Value
Current CPUFANOUT1 Output Value	Bank0 Index 61h	CPUFANOUT1 Output Value Select	80h / FFh by strapping	bits 7~0 CPUFANOUT1 Value

**Relative Register-at SMART FAN™ III Control Mode**

SMART FAN™ III MODE	TARGET TEMPERATURE	TOLERANCE	STOP VALUE (MIN. FAN OUTPUT)	MAX. FAN OUTPUT	STOP TIME
CPUFANOUT0	Bank0, Index 06h	Bank0, Index 07h, bits 4-7	Bank0, Index 09h	Bank0, Index 67h	Bank0, Index 0Dh
CPUFANOUT1	Bank0, Index 63h	Bank0, Index 62h, bits 0-3	Bank0, Index 64h	Bank0, Index 69h	Bank0, Index 66h
SMART FAN™ III MODE	OUTPUT STEP	STEP DOWN TIME	STEP UP TIME	KEEP MIN. FAN OUTPUT VALUE	/
CPUFANOUT0	Bank0, Index 68h	Bank0, Index 0Eh	Bank0, Index 0Fh	Bank0, Index 12h, bit 4	
CPUFANOUT1	Bank0, Index 6Ah			Bank0, Index 12h, bit 6	



## 7.7 Interrupt Detection

### 7.7.1 SMI# Interrupt Mode

The SMI#/OVT# pin (pin 5) is a multi-function pin. It can be in SMI# mode or in OVT# mode by setting Configuration Register CR[29h], bit 6 to one or zero, respectively. In SMI# mode, it can monitor voltages, fan counts, or temperatures.

#### 7.7.1.1. Voltage SMI# Mode

The SMI# pin can create an interrupt if a voltage exceeds a specified high limit or falls below a specified low limit. This interrupt must be reset by reading all the interrupt status registers, or subsequent events do not generate interrupts. This mode is illustrated in the following figure.

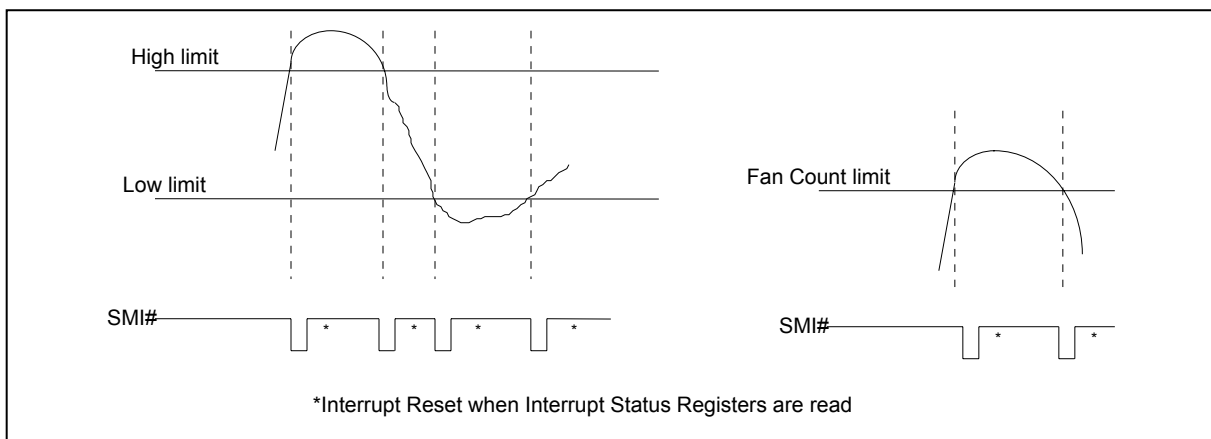

#### 7.7.1.2. Fan SMI# Mode

The SMI# pin can create an interrupt if a fan count crosses a specified fan limit (rises above it or falls below it). This interrupt must be reset by reading all the interrupt status registers, or subsequent events do not generate interrupts. This mode is illustrated in the figure above.

#### 7.7.1.3. Temperature SMI# Mode

The SMI# pin can create interrupts that depend on the temperatures measured by SYSTIN, CPUTIN, and AUX TIN. These interrupts are divided into two parts, one for SYSTIN and the other for CPUTIN / AUX TIN.

##### 7.7.1.3.1. Temperature Sensor 1(SYSTIN) SMI# Interrupt

The SMI# pin has three interrupt modes with SYSTIN.

###### (1) Comparator Interrupt Mode

This mode is enabled by setting  $T_{HYST}$  (Temperature Hysteresis) to 127°C.

In this mode, the SMI# pin can create an interrupt as long as the current temperature exceeds  $T_O$  (Over Temperature). This interrupt can be reset by reading all the interrupt status registers, or subsequent events do not generate interrupts. If the interrupt is reset, the SMI# pin continues to create interrupts until the temperature goes below  $T_O$ . This is illustrated in the figure below.

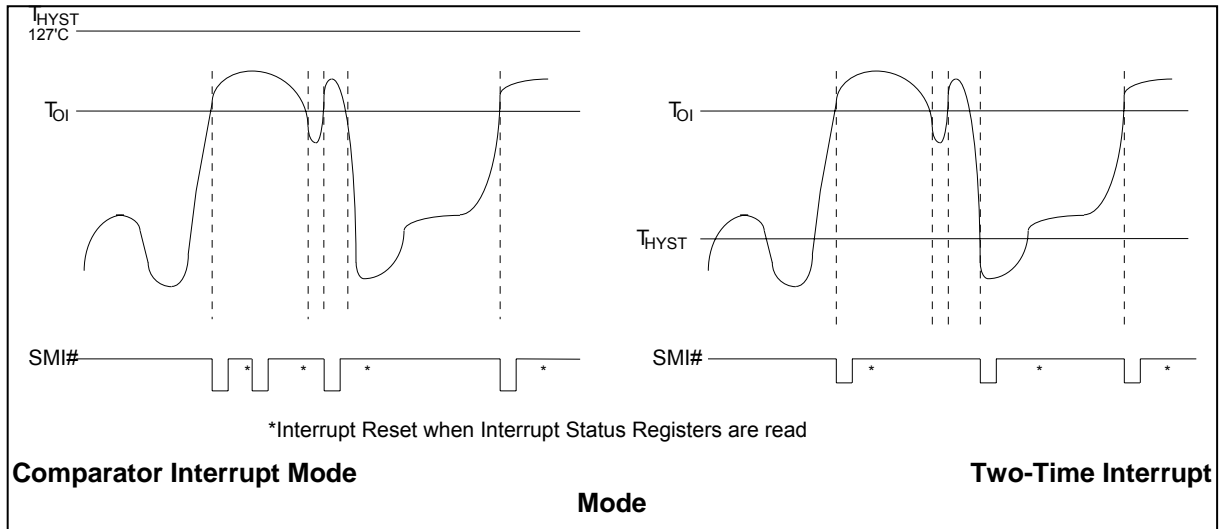

### (2) Two-Time Interrupt Mode

This mode is enabled by setting  $T_{HYST}$  (Temperature Hysteresis) lower than  $T_O$  and setting Bank0 Index 4Ch, bit 5 to zero.

In this mode, the SMI# pin can create an interrupt when the current temperature rises above  $T_O$  or when the current temperature falls below  $T_{HYST}$ . Once the temperature rises above  $T_O$ , however, and generates an interrupt, this mode does not generate additional interrupts, even if the temperature remains above  $T_O$ , until the temperature falls below  $T_{HYST}$ . This interrupt must be reset by reading all the interrupt status registers, or subsequent events do not generate interrupts. This is illustrated in the figure above.

### (3) One-Time Interrupt Mode

This mode is enabled by setting  $T_{HYST}$  (Temperature Hysteresis) lower than  $T_O$  and setting Bank0 Index 4Ch, bit 5 to one.

In this mode, the SMI# pin can create an interrupt when the current temperature rises above  $T_O$ . Once the temperature rises above  $T_O$ , however, and generates an interrupt, this mode does not generate additional interrupts, even if the temperature remains above  $T_O$ , until the temperature falls below  $T_{HYST}$ . This interrupt must be reset by reading all the interrupt status registers, or subsequent events do not generate interrupts. This is illustrated in the following figure.

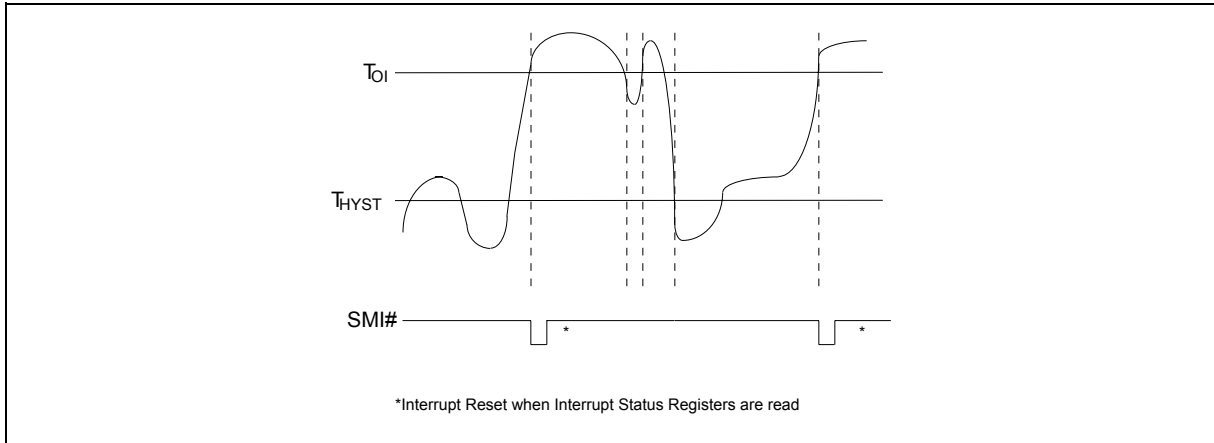

**One-Time Interrupt Mode**

**7.7.1.3.2. Temperature Sensor 2(CPUTIN) And Sensor 3(AUXTIN) SMI# Interrupt**

The SMI# pin has two interrupt modes with CPUTIN / AUXTIN.

**(1) Comparator Interrupt Mode**

This mode is enabled by setting Bank0 Index 4Ch, bit 6, to one.

In this mode, the SMI# pin can create an interrupt when the current temperature exceeds  $T_O$  (Over Temperature) and continues to create interrupts until the temperature falls below  $T_{HYST}$ . This interrupt can be reset by reading all the interrupt status registers, or subsequent events do not generate interrupts. This is illustrated in the figure below.

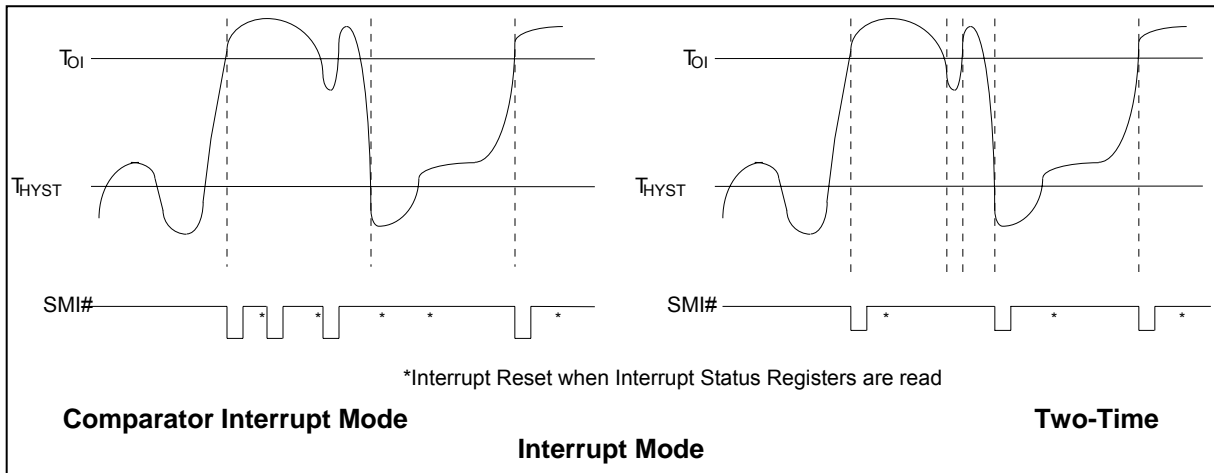

**Comparator Interrupt Mode**

**Interrupt Mode**

**Two-Time**





## (2) Two-Times Interrupt Mode

This mode is enabled by setting Bank0 Index 4Ch, bit 6, to zero.

In this mode, the SMI# pin can create an interrupt when the current temperature rises above  $T_O$  or when the current temperature falls below  $T_{HYST}$ . Once the temperature rises above  $T_O$ , however, and generates an interrupt, this mode does not generate additional interrupts, even if the temperature remains above  $T_O$ , until the temperature falls below  $T_{HYST}$ . This interrupt must be reset by reading all the interrupt status registers, or subsequent events do not generate interrupts. This is illustrated in the figure above.

### 7.7.2 OVT# Interrupt Mode

The SMI#/OVT# pin is a multi-function pin. It can be in SMI# mode or in OVT# mode by setting Configuration Register CR[29h], bit 6 to one or zero, respectively. In OVT# mode, it can monitor temperatures, and it is enabled or disabled for SYSTIN, CPUTIN, and AUXIN by Bank0 Index 18h, bit 6; Bank0 Index 4Ch, bit 3; and Bank0 Index 4Ch, bit4.

The OVT# pin has two interrupt modes, comparator and interrupt. The modes are illustrated in this figure.

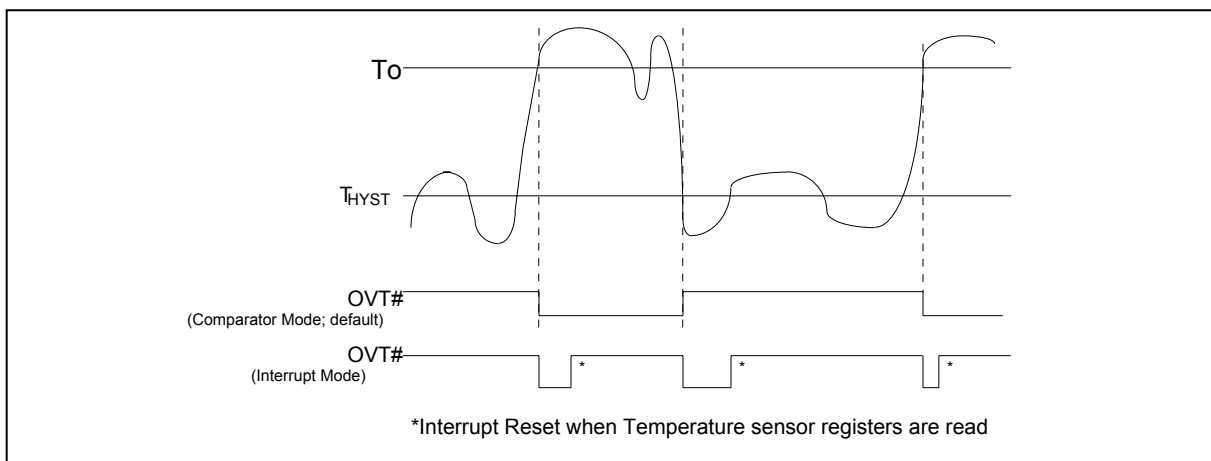

If Bank0 Index 18h, bit 4, Bank1 Index 52h, bit 1, and Bank2 Index 52h, bit1 are set to zero, the OVT# pin is in comparator mode. In comparator mode, the OVT# pin can create an interrupt once the current temperature exceeds  $T_O$  and continues to create interrupts until the temperature falls below  $T_{HYST}$ . The OVT# pin is asserted once the temperature has exceeded  $T_O$  and has not yet fallen below  $T_{HYST}$ .

If Bank0 Index 18h, bit 4, Bank1 Index 52h, bit1, and Bank2 Index 52h, bit 1 are set to one, the OVT# pin is in interrupt mode. In interrupt mode, the OVT# pin can create an interrupt once the current temperature rises above  $T_O$  or when the temperature falls below  $T_{HYST}$ . Once the temperature rises above  $T_O$ , however, and generates an interrupt, this mode does not generate additional interrupts, even if the temperature remains above  $T_O$ , until the temperature falls below  $T_{HYST}$ . This interrupt must be reset by reading all the interrupt status registers. The OVT# pin is asserted when an interrupt is generated and remains asserted until the interrupt is reset.



### 7.7.3 Caseopen Detection

The purpose of Caseopen function is used to detect whether the computer case is opened. This feature must be able to function even when there is no 3VSB power. Consequently, the power source for the circuit is from either Pin 74 (VBAT) or Pin 61 (3VSB). 3VSB is the default power source. If there is no 3VSB power, the power source is VBAT. This is designed to save power consumption of the battery.

When the case is closed, the signal of Pin 76 must be pulled high by an externally pulled-up  $2M\Omega$  resistor that is connected to Pin 74. Once the case is opened, the signal will be changed from high to low. Meanwhile, the detection circuit inside the IC latches the signal. As a result, the interrupt status and the real-time status can be read at the registers next time when the computer is booted. The status will not be cleared unless Bank 0, Index 46h, bit 7, or CR[E6h] bit 5 at Logical Device A is set to "1" first and then to "0".

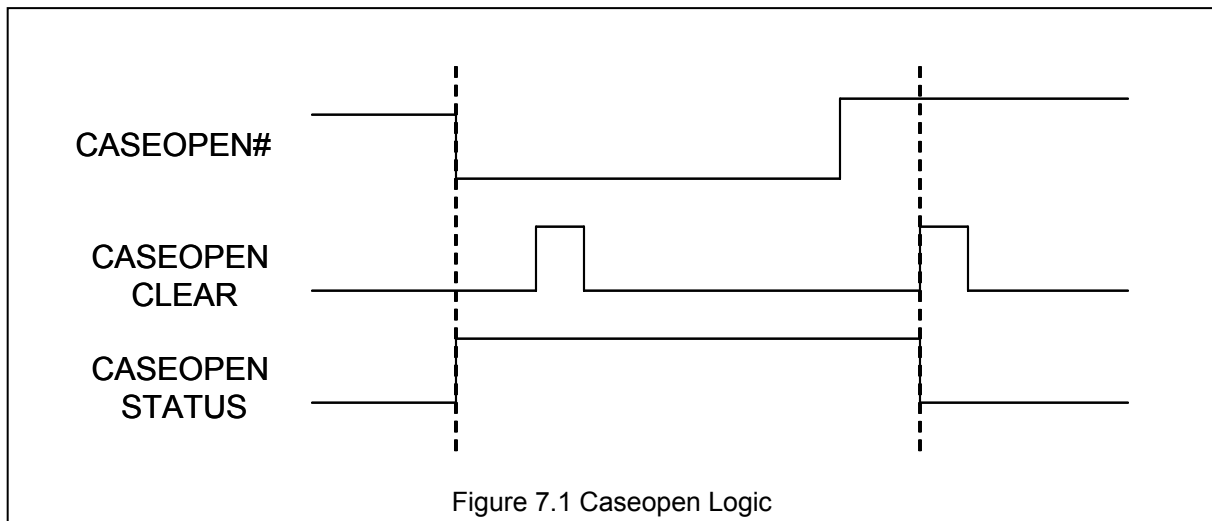

Figure 7.1 Caseopen Logic



#### **7.7.4 BEEP Alarm Function**

The W83627DHG provides an alarm output function at the BEEP/SO pin. The BEEP/SO pin is a multi-function pin and can be configured as BEEP output, if Configuration Register CR[24h], bit 1 is set to zero.

The BEEP outputs a warning tone when one of the monitored parameters in the following events is out of the preset range.

- Any voltage input of the nine pins (CPUVCORE, VIN[0..3], 3VCC, AVCC, 3VSB and VBAT) is out of the allowed range;
- Any temperature input of the three pins (SYSTIN, CPUTIN and AUCTIN) exceeds the limit;
- Any fan input of the five pins (SYSFANIN, CPUFANIN0, AUXFANIN0, CPUFANIN1 and AUXFANIN1) exceeds the limit;
- CASEOPEN# input pin is sampled low;
- User-defined bit (Bank 4, Index 53h, bit 5) is written to 1.

Whether the BEEP alarm function is enabled or disabled is determined by the control bit at Hardware Monitor Device, Bank 0, Index 57h, bit 7. Also, each event has their individual enable bit at Hardware Monitor Device, Bank 0, Index 56h bit[7:0], Index 57h bit[6:0] and Bank 4, Index 53h, bit[1:0].

BEEP/SO is an open-drain output pin and its default state is low. When the BEEP alarm function is activated, this pin repeatedly outputs 600 Hz square wave for 0.5 second and 1.2 KHz square wave for 0.5 second in turn until the enable bit or the abnormal event is cleared.



**8. HARDWARE MONITOR REGISTER SET**

The base address of the Address Port and Data Port is specified in registers CR60 and CR61 of Device B, the hardware monitor device. CR60 is the high byte, and CR61 is the low byte. The Address Port and Data Port are located at the base address, plus 5h and 6h, respectively. For example, if CR60 is 02h and CR61 is 90h, the Address Port is at 0x295h, and the Data Port is at 0x296h.

**8.1 Address Port (Port x5h)**

Address Port: Port +5h  
 Power on Default Value 00h  
 Attribute: Bit 6:0 Read/write , Bit 7: Reserved  
 Size: 8 bits

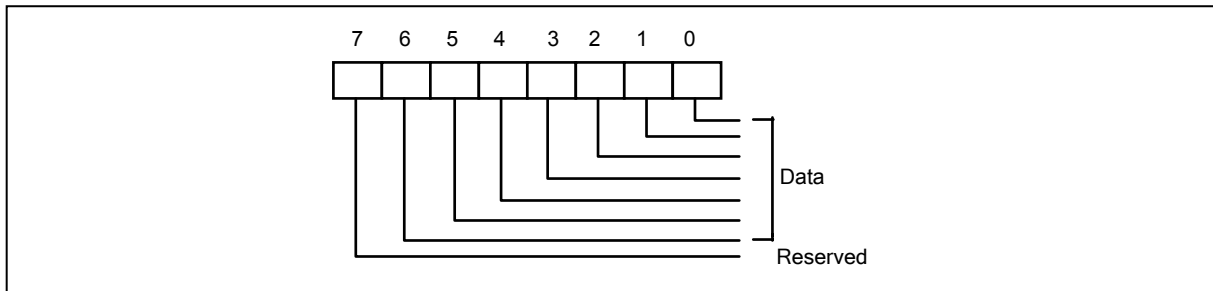

Bit7: Reserved  
 Bit 6-0: Read/Write

BIT 7	BIT 6	BIT 5	BIT 4	BIT 3	BIT 2	BIT 1	BIT 0
Reserved	Address Pointer (Power On default 00h)						
(Power On default 0)	A6	A5	A4	A3	A2	A1	A0

**8.2 Data Port (Port x6h)**

Data Port: Port +6h  
 Power on Default Value 00h  
 Attribute: Read/Write  
 Size: 8 bits

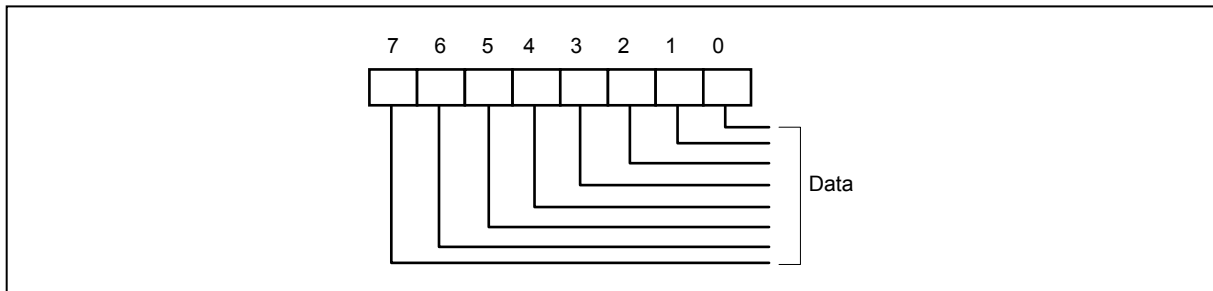

Bit 7-0: Data to be read from or to be written to Value RAM and Register.



### 8.3 SYSFANOUT PWM Output Frequency Configuration Register - Index 00h (Bank 0)

Register Location: 00h  
 Power on Default Value: 04h  
 Attribute: Read/Write  
 Size: 8 bits

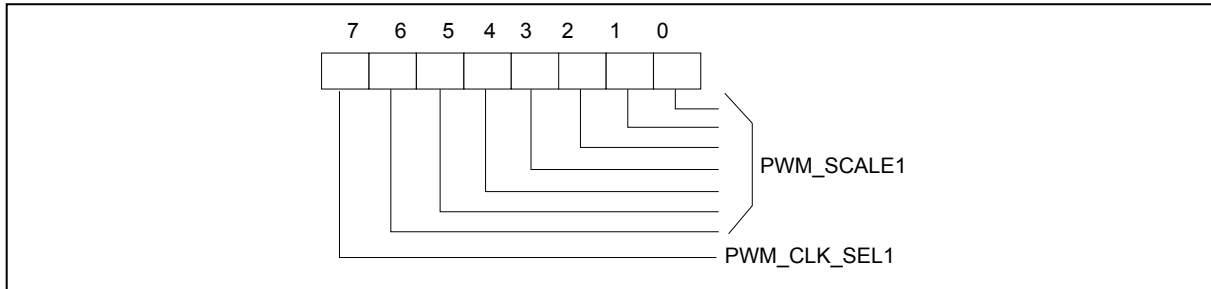

The register is meaningful only when SYSFANOUT is programmed for PWM output (i.e., Bank0 Index 04h, bit 0 is 0).

Bit 7: SYSFANOUT PWM Input Clock Source Select. This bit selects the clock source for PWM output frequency.

0: clock source is 24 MHz.

1: clock source is 180 KHz.

Bit 6-0: SYSFANOUT PWM Pre-Scale divider. The clock source for PWM output is divided by this seven-bit value to calculate the actual PWM output frequency.

$$\text{PWM output frequency} = \frac{\text{Input Clock}}{\text{Pre\_Scale Divider}} * \frac{1}{256}$$

The maximum value of the divider is 127 (7Fh), and it should not be set to 0.

### 8.4 SYSFANOUT Output Value Select Register - Index 01h (Bank 0)

Register Location: 01h  
 Power on Default Value: FFh  
 Attribute: Read/Write  
 Size: 8 bits

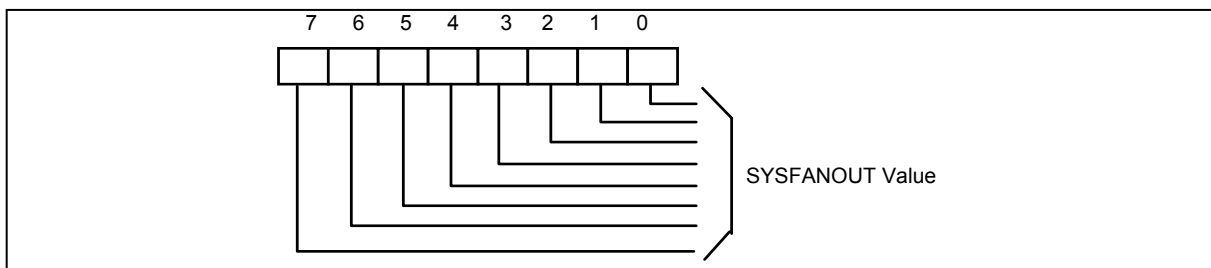



**(1) If SYSFANOUT is programmed for PWM output (Bank0 Index 04h, bit0 is 0)**

Bit 7-0: The PWM duty cycle is equal to this eight-bit value, divided by 255, times 100%. FFh creates a duty cycle of 100%, and 00h creates a duty cycle of 0%.

**(2) If SYSFANOUT is programmed for DC Voltage output (Bank0 Index 04h, bit0 is 1)**

Bit 7-2: SYSFANOUT voltage control. The output voltage is calculated according to this equation.

$$\text{OUTPUT Voltage} = AVCC * \frac{FANOUT}{64}$$

Bit 1-0: Reserved.

### 8.5 CPUFANOUT0 PWM Output Frequency Configuration Register - Index 02h (Bank 0)

Register Location: 02h  
 Power on Default Value: 04h  
 Attribute: Read/Write  
 Size: 8 bits

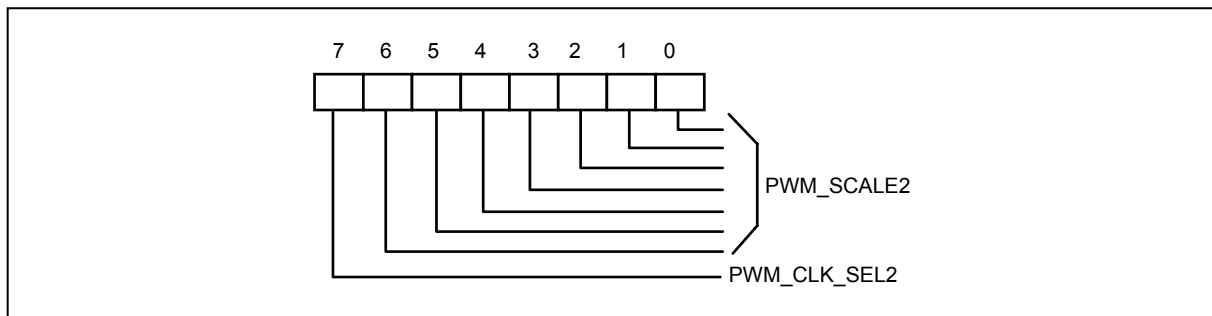

**The register is meaningful only when CPUFANOUT0 is programmed for PWM output.**

Bit 7: CPUFANOUT0 PWM Input Clock Source Select. This bit selects the clock source for PWM output.

- 0: clock source is 24 MHz.
- 1: clock source is 180 KHz.

Bit 6-0: CPUFANOUT0 PWM Pre-Scale divider. The clock source for PWM output is divided by this seven-bit value to calculate the actual PWM output frequency.

$$\text{PWM output frequency} = \frac{\text{Input Clock}}{\text{Pre\_Scale Divider}} * \frac{1}{256}$$

The maximum value of the divider is 127 (7Fh), and it should not be set to 0.



**8.6 CPUFANOUT0 Output Value Select Register - Index 03h (Bank 0)**

Register Location: 03h  
 Power on Default Value: Strap by FAN\_SET(Pin 117)  
 Attribute: Read/Write  
 Size: 8 bits

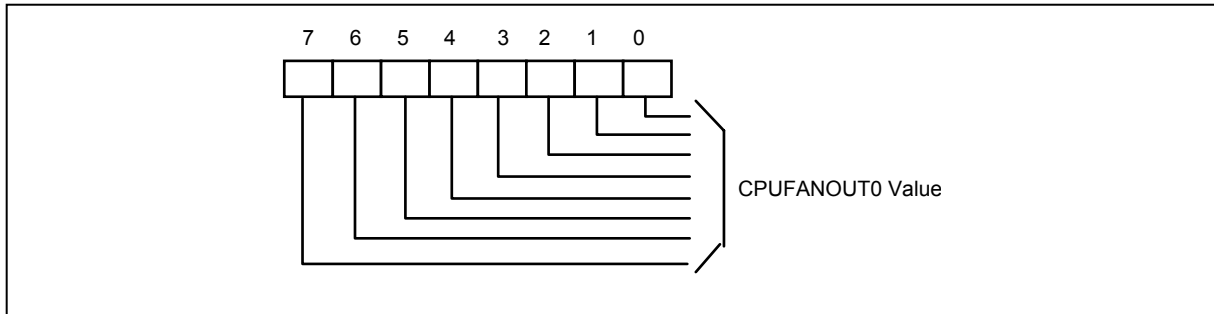

**(1) If CPUFANOUT0 is programmed for PWM output (Bank0 Index 04h, bit1 is 0)**

Bit 7-0: CPUFANOUT0 PWM Duty Cycle. The PWM duty cycle is equal to this eight-bit value, divided by 255, times 100%. FFh creates a duty cycle of 100%, and 00h creates a duty cycle of 0%

**(2) If CPUFANOUT0 is programmed for DC Voltage output (Bank0 Index 04h, bit1 is 1)**

Bit 7-2: CPUFANOUT0 voltage control. The output voltage is calculated according to this equation.

$$\text{OUTPUT Voltage} = AVCC * \frac{FANOUT}{64}$$

Bit 1-0: Reserved.

**8.7 FAN Configuration Register I - Index 04h (Bank 0)**

Register Location: 04h  
 Power on Default Value: 01h  
 Attribute: Read/Write  
 Size: 8 bits

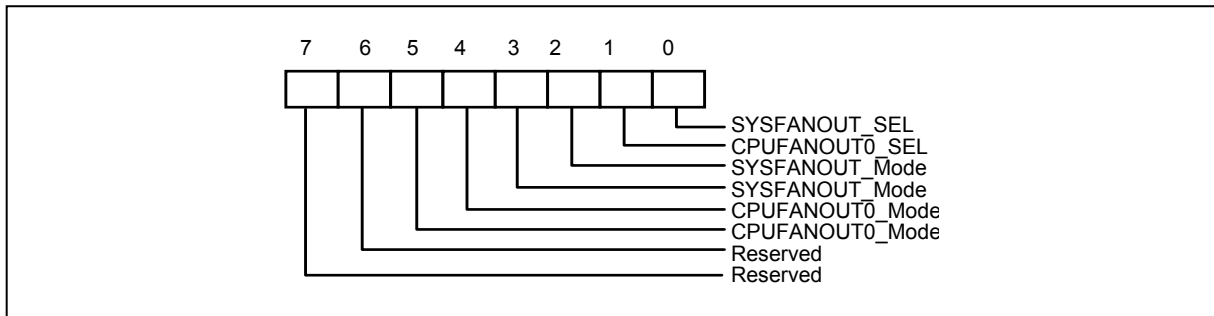



Bit 7-6: Reserved

Bit 5-4: CPUFANOUT0 mode control.

00: CPUFANOUT0 is in Manual Mode. (Default)

01: CPUFANOUT0 is in Thermal Cruise™ Mode.

10: CPUFANOUT0 is in Fan Speed Cruise™ Mode.

11: CPUFANOUT0 is in SMART FAN™ III Mode.

Bit 3-2: SYSFANOUT mode control.

00: SYSFANOUT is as Manual Mode. (Default)

01: SYSFANOUT is as Thermal Cruise™ Mode.

10: SYSFANOUT is as Fan Speed Cruise™ Mode.

11: Reserved and no function.

Bit 1: CPUFANOUT0 output mode selection.

0: CPUFANOUT0 pin produces a PWM output duty cycle. (Default)

1: CPUFANOUT0 pin produces DC output.

Bit 0: SYSFANOUT output mode selection.

0: SYSFANOUT pin produces a PWM duty cycle output.

1: SYSFANOUT pin produces DC output. (Default)

### 8.8 SYSTIN Target Temperature Register/ SYSFANIN Target Speed Register - Index 05h (Bank 0)

Register Location: 05h

Power on Default Value: 00h

Attribute: Read/Write

Size: 8 bits

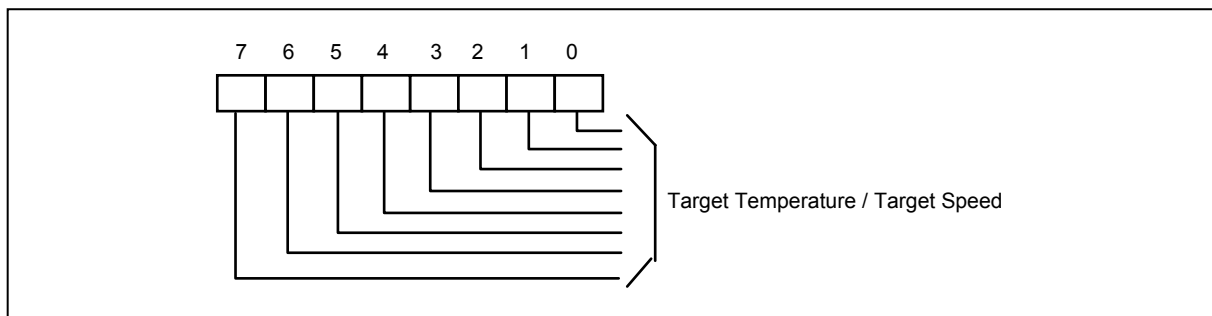

(1) In Thermal Cruise™ mode,

Bit 7: Reserved.

Bit 6-0: SYSTIN Target Temperature.

(2) In Fan Speed Cruise™ mode,

Bit 7-0: SYSFANIN Target Speed.





**8.9 CPUTIN Target Temperature Register/ CPUFANIN0 Target Speed Register - Index 06h (Bank 0)**

Register Location: 06h  
 Power on Default Value: 00h  
 Attribute: Read/Write  
 Size: 8 bits

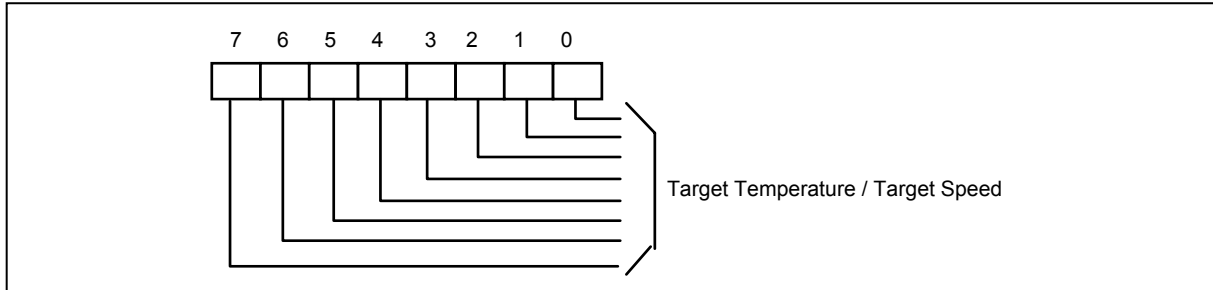

(1) In Thermal Cruise™ mode or SMART FAN™ III mode,  
 Bit 7: Reserved.  
 Bit 6-0: CPUTIN Target Temperature.

(2) In Fan Speed Cruise™ mode,  
 Bit 7-0: CPUFANIN0 Target Speed.

**8.10 Tolerance of Target Temperature or Target Speed Register - Index 07h (Bank 0)**

Register Location: 07h  
 Power on Default Value: 00h  
 Attribute: Read/Write  
 Size: 8 bits

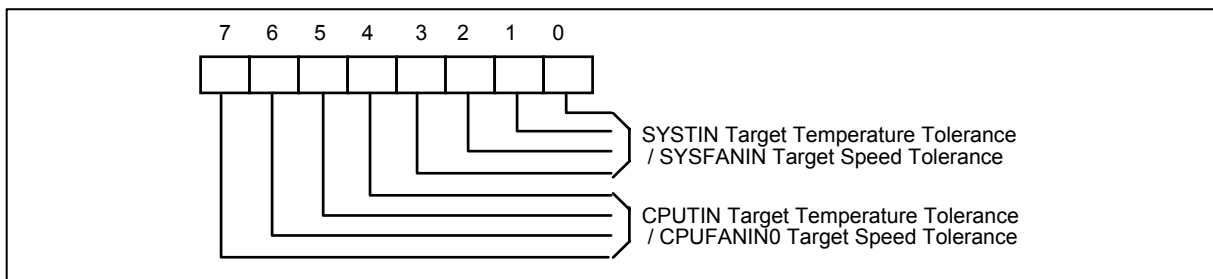

(1) In Thermal Cruise™ mode or SMART FAN™ III mode,  
 Bit 7-4: Tolerance of CPUTIN Target Temperature.  
 Bit 3-0: Tolerance of SYSTIN Target Temperature.

(2) In Fan Speed Cruise™ mode,  
 Bit 7-4: Tolerance of CPUFANIN0 Target Speed.



Bit 3-0: Tolerance of SYSFANIN Target Speed.

### 8.11 SYSFANOUT Stop Value Register - Index 08h (Bank 0)

Register Location: 08h  
 Power on Default Value: 01h  
 Attribute: Read/Write  
 Size: 8 bits

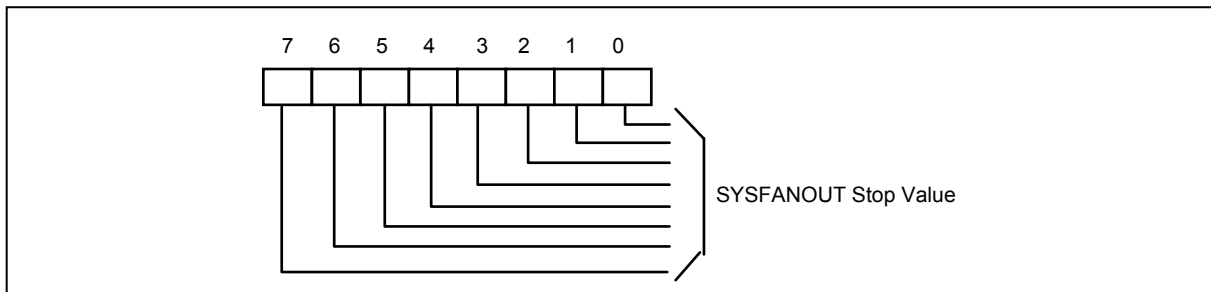

In Thermal Cruise™ mode, the SYSFANOUT value decreases to this eight-bit value if the temperature stays below the lowest temperature limit. This value should not be zero.

Please note that Stop Value does not mean that the fan really stops. It means that if the temperature keeps below low temperature limit, then the fan speed keeps on decreasing until reaching a minimum value, and this is Stop Value.

### 8.12 CPUFANOUT0 Stop Value Register - Index 09h (Bank 0)

Register Location: 09h  
 Power on Default Value: 01h  
 Attribute: Read/Write  
 Size: 8 bits

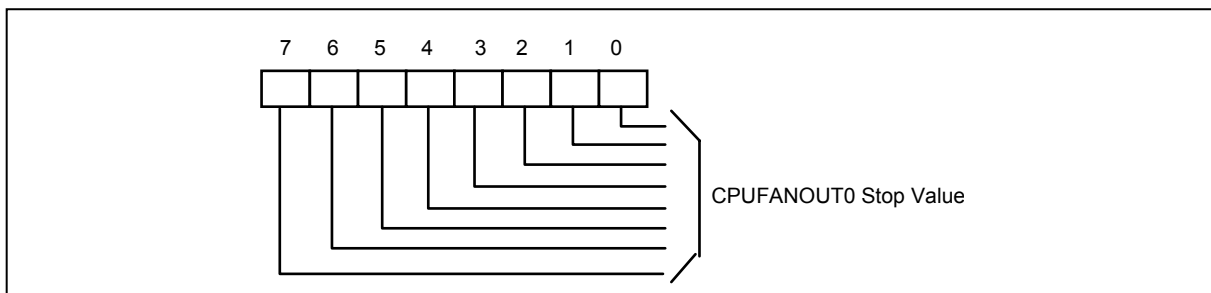

In Thermal Cruise™ mode or SMART FAN™ III mode, the CPUFANOUT0 value decreases to this eight-bit value if the temperature stays below the lowest temperature limit. This value should not be zero.

Please note that Stop Value does not mean that the fan really stops. It means that if the temperature keeps below low temperature limit, then the fan speed keeps on decreasing until reaching a minimum value, and this is Stop Value.



**8.13 SYSFANOUT Start-up Value Register - Index 0Ah (Bank 0)**

Register Location: 0Ah  
 Power on Default Value: 01h  
 Attribute: Read/Write  
 Size: 8 bits

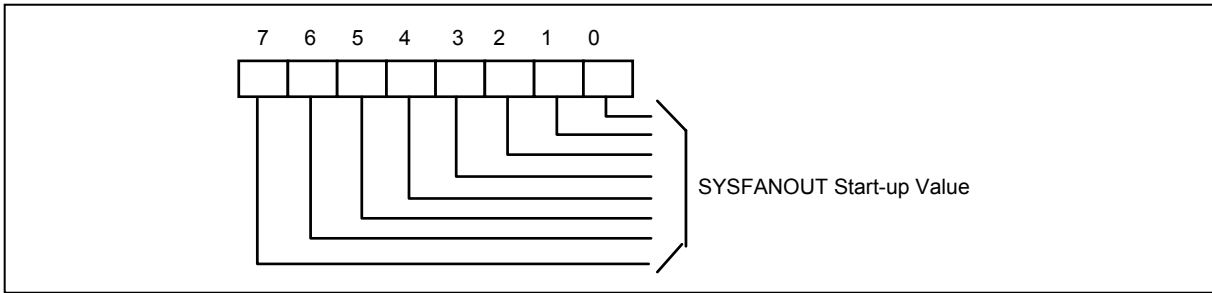

In Thermal Cruise™ mode, SYSFANOUT value increases from zero to this eight-bit register value to provide a minimum value to turn on the fan.

**8.14 CPUFANOUT0 Start-up Value Register - Index 0Bh (Bank 0)**

Register Location: 0Bh  
 Power on Default Value: 01h  
 Attribute: Read/Write  
 Size: 8 bits

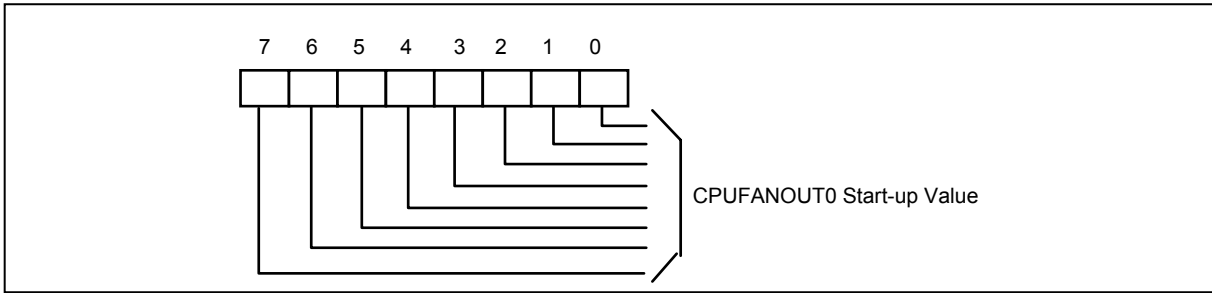

In Thermal Cruise™ mode, CPUFANOUT0 value increases from zero to this eight-bit register value to provide a minimum value to turn on the fan.



### 8.15 SYSFANOUT Stop Time Register - Index 0Ch (Bank 0)

Register Location: 0Ch  
 Power on Default Value: 3Ch  
 Attribute: Read/Write  
 Size: 8 bits

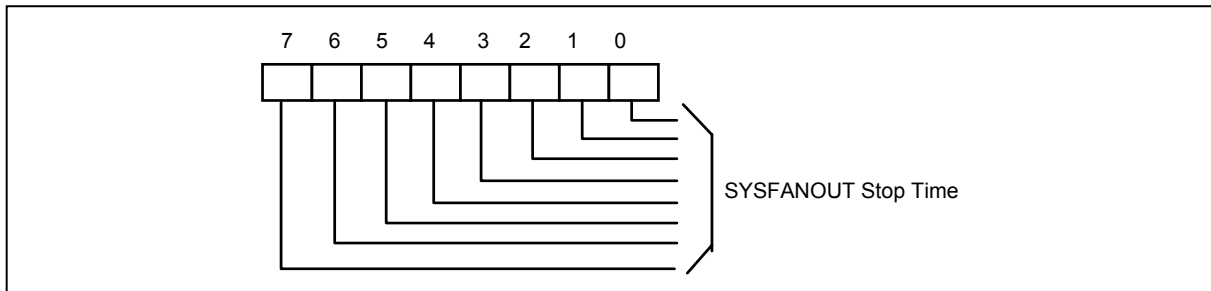

In Thermal Cruise™ mode, if the stop value is enabled, this register determines the amount of time it takes the SYSFANOUT value to fall from the stop value to zero.

(1)For PWM output:

The units are intervals of 0.1 seconds. The default time is 6 seconds.

(2)For DC output:

The units are intervals of 0.4 seconds. The default time is 24 seconds.

### 8.16 CPUFANOUT0 Stop Time Register - Index 0Dh (Bank 0)

Register Location: 0Dh  
 Power on Default Value: 3Ch  
 Attribute: Read/Write  
 Size: 8 bits

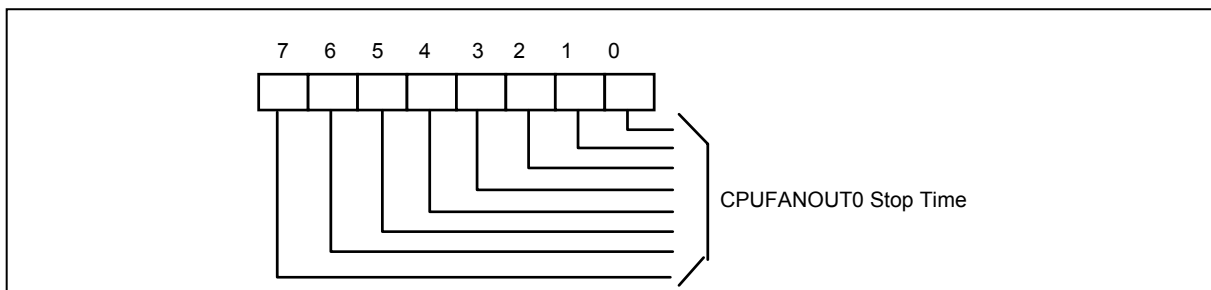

In Thermal Cruise™ mode or SMART FAN™ III mode, this register determines the amount of time it takes the CPUFANOUT0 value to fall from the stop value to zero.

(1)For PWM output:

The units are intervals of 0.1 seconds. The default time is 6 seconds.

(2)For DC output:

The units are intervals of 0.4 seconds. The default time is 24 seconds.



### 8.17 Fan Output Step Down Time Register - Index 0Eh (Bank 0)

Register Location: 0Eh  
 Power on Default Value: 0Ah  
 Attribute: Read/Write  
 Size: 8 bits

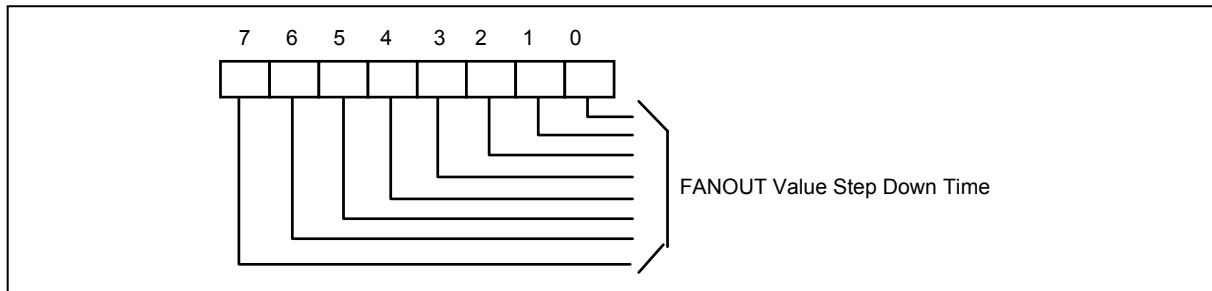

In SMART FAN™ mode, this register determines the amount of time it takes FANOUT to decrease its value by one step.

(1)For PWM output:

The units are intervals of 0.1 seconds. The default time is 1 seconds.

(2)For DC output:

The units are intervals of 0.4 seconds. The default time is 4 seconds.

### 8.18 Fan Output Step Up Time Register - Index 0Fh (Bank 0)

Register Location: 0Fh  
 Power on Default Value: 0Ah  
 Attribute: Read/Write  
 Size: 8 bits

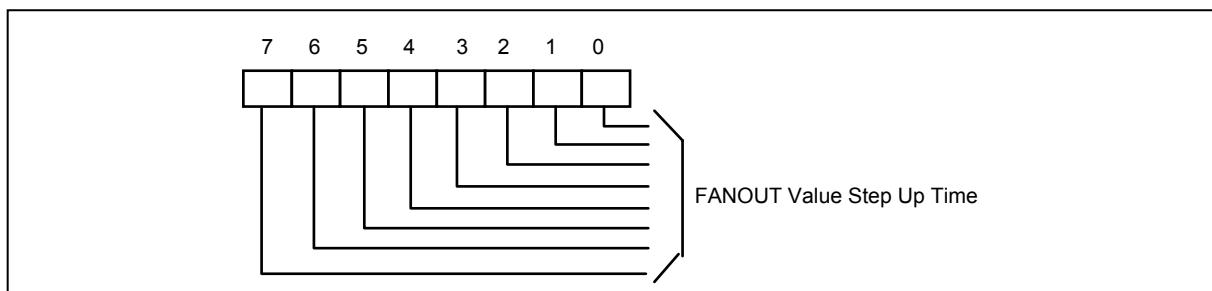

In SMART FAN™ mode, this register determines the amount of time it takes FANOUT to increase its value by one step.

(1)For PWM output:

The units are intervals of 0.1 second. The default time is 1 second.

(2)For DC output:

The units are intervals of 0.4 second. The default time is 4 seconds.



### 8.19 AUXFANOUT PWM Output Frequency Configuration Register - Index 10h (Bank 0)

Register Location: 10h  
 Power on Default Value: 04h  
 Attribute: Read/Write  
 Size: 8 bits

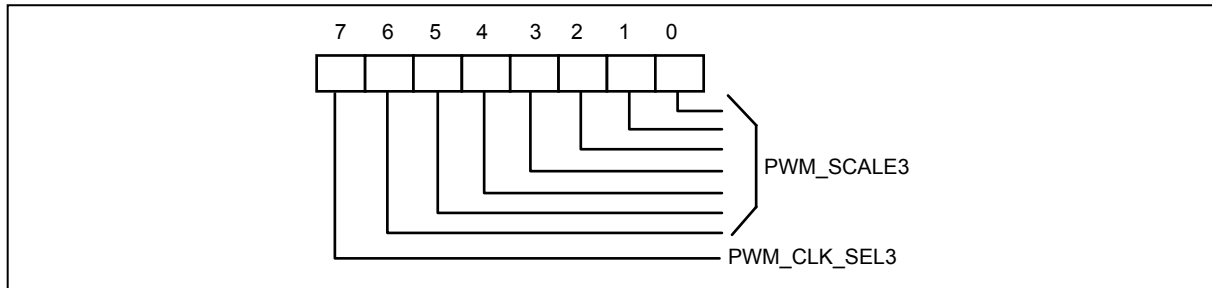

**The register is only meaningful when AUXFANOUT is programmed for PWM output(i.e., Bank0 Index 12h, bit 0 is 0).**

Bit 7: AUXFANOUT PWM Input Clock Source Select. This bit selects the clock source of PWM output frequency.

0: clock source is 24 MHz.

1: clock source is 180 KHz.

Bit 6-0: AUXFANOUT PWM Pre-Scale divider. The clock source for PWM output is divided by this seven-bit value to calculate the actual PWM output frequency.

$$\text{PWM output frequency} = \frac{\text{Input Clock}}{\text{Pre\_Scale Divider}} * \frac{1}{256}$$

The maximum value of the divider is 127 (7Fh), and it should not be set to 0.

### 8.20 AUXFANOUT Output Value Select Register - Index 11h (Bank 0)

Register Location: 11h  
 Power on Default Value: FFh  
 Attribute: Read/Write  
 Size: 8 bits

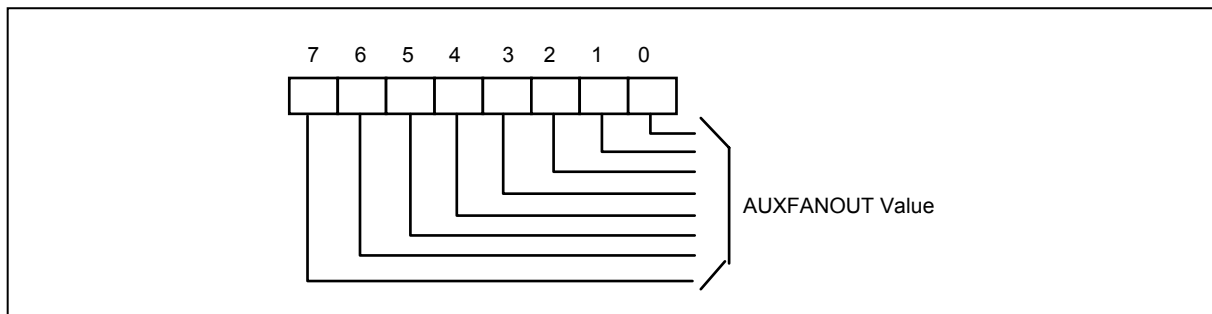



**(1) If AUXFANOUT is programmed for PWM output (Bank0 Index 12h, bit0 is 0)**

Bit 7-0: AUXFANOUT PWM Duty Cycle. The PWM duty cycle is equal to this eight-bit value, divided by 255, times 100%. FFh creates a duty cycle of 100%, and 00h creates a duty cycle of 0%.

**(2) If AUXFANOUT is programmed for DC output (Bank0 Index 12h, bit0 is 1)**

Bit 7-2: AUXFANOUT voltage control. The output voltage is calculated according to this equation.

$$\text{OUTPUT Voltage} = AVCC * \frac{FANOUT}{64}$$

Bit 1-0: Reserved.

## 8.21 FAN Configuration Register II - Index 12h (Bank 0)

Register Location: 12h  
 Power on Default Value: 00h  
 Attribute: Read/Write  
 Size: 8 bits

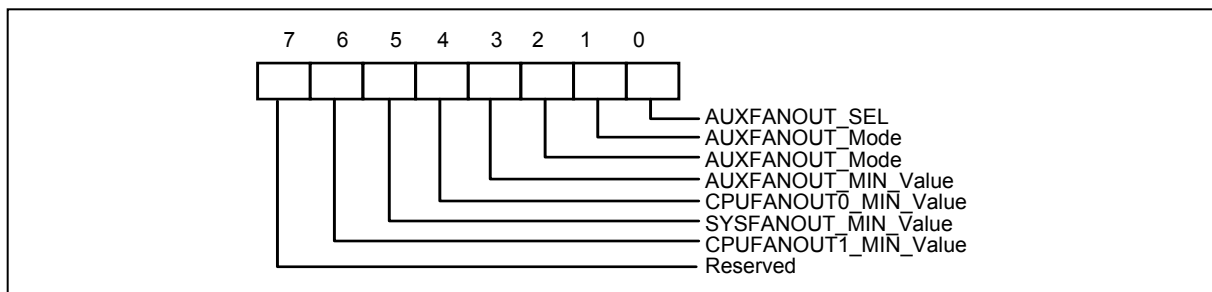

Bit 7: Reserved

Bit 6:

- 0: CPUFANOUT1 value decreases to zero when the temperature goes below the target range.
- 1: CPUFANOUT1 value decreases to the value specified in Index 64h when the temperature goes below the target range.

Bit 5:

- 0: SYSFANOUT value decreases to zero when the temperature goes below the target range.
- 1: SYSFANOUT value decreases to the value specified in Index 08h when the temperature goes below the target range.

Bit 4:

- 0: CPUFANOUT0 value decreases to zero when the temperature goes below the target range.
- 1: CPUFANOUT0 value decreases to the value specified in Index 09h when the temperature goes below the target range.

Bit 3:

- 0: AUXFANOUT value decreases to zero when the temperature goes below the target range.
- 1: AUXFANOUT value decreases to the value specified in Index 17h when the temperature goes below the target range.



Bit 2-1: AUXFANOUT mode control.

- 00: AUXFANOUT is in Manual Mode. (Default)
- 01: AUXFANOUT is in Thermal Cruise™ Mode.
- 10: AUXFANOUT is in Fan Speed Cruise™ Mode.
- 11: Reserved and no function.

Bit 0:

- 0: AUXFANOUT pin produces a PWM output duty cycle. (Default)
- 1: AUXFANOUT pin produces DC output.

**8.22 AUXTIN Target Temperature Register/ AUXFANIN0 Target Speed Register - Index 13h (Bank 0)**

Register Location: 13h  
 Power on Default Value: 00h  
 Attribute: Read/Write  
 Size: 8 bits

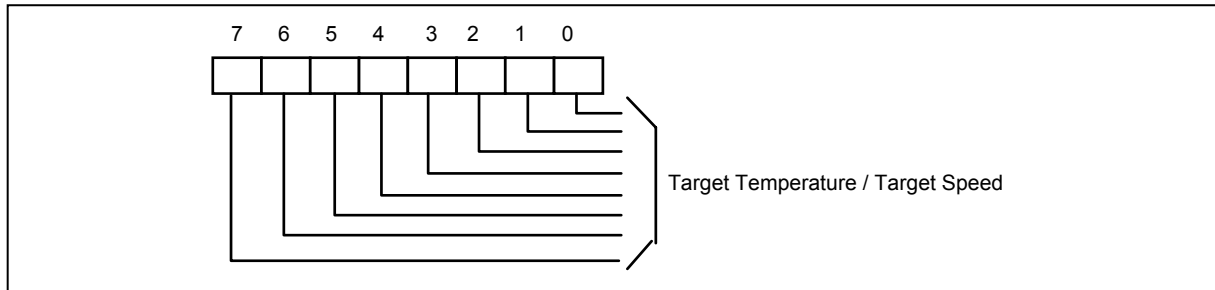

(1)In Thermal Cruise™ mode:

- Bit 7: Reserved.
- Bit 6-0: AUXTIN Target Temperature.

(2)In Fan Speed Cruise™ mode:

- Bit 7-0: AUXFANIN0 Target Speed.





**8.23 Tolerance of Target Temperature or Target Speed Register - Index 14h (Bank 0)**

Register Location: 14h  
 Power on Default Value: 00h  
 Attribute: Read/Write  
 Size: 8 bits

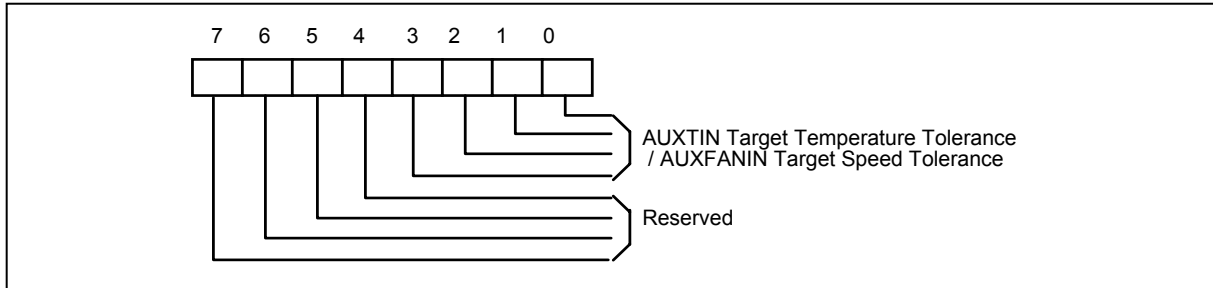

- (1) In Thermal Cruise™ mode:  
 Bit 3-0: Tolerance of AUXTIN Target Temperature.
- (2) In Fan Speed Cruise™ mode:  
 Bit 3-0: Tolerance of AUXFANIN0 Target Speed.

**8.24 AUXFANOUT Stop Value Register - Index 15h (Bank 0)**

Register Location: 15h  
 Power on Default Value: 01h  
 Attribute: Read/Write  
 Size: 8 bits

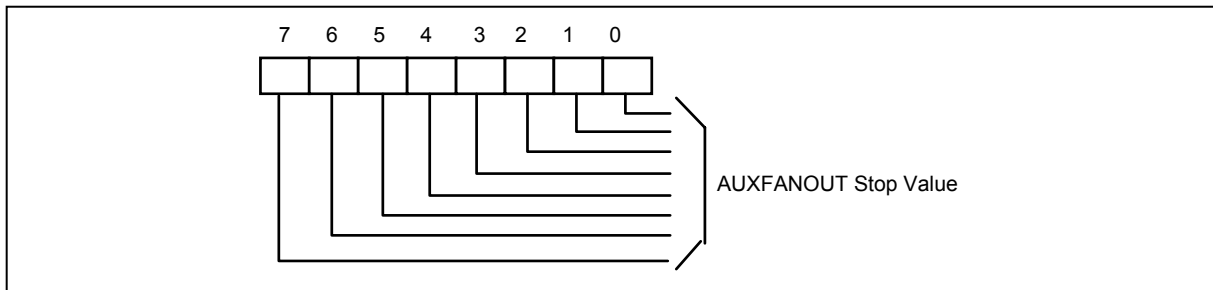

In Thermal Cruise™ mode, the AUXFANOUT value decreases to this eight-bit value if the temperature stays below the lowest temperature limit. This value should not be zero.  
 Please note that Stop Value does not mean that the fan really stops. It means that if the temperature keeps below low temperature limit, then the fan speed keeps on decreasing until reaching a minimum value, and this is Stop Value.



### 8.25 AUXFANOUT Start-up Value Register - Index 16h (Bank 0)

Register Location: 16h  
 Power on Default Value: 01h  
 Attribute: Read/Write  
 Size: 8 bits

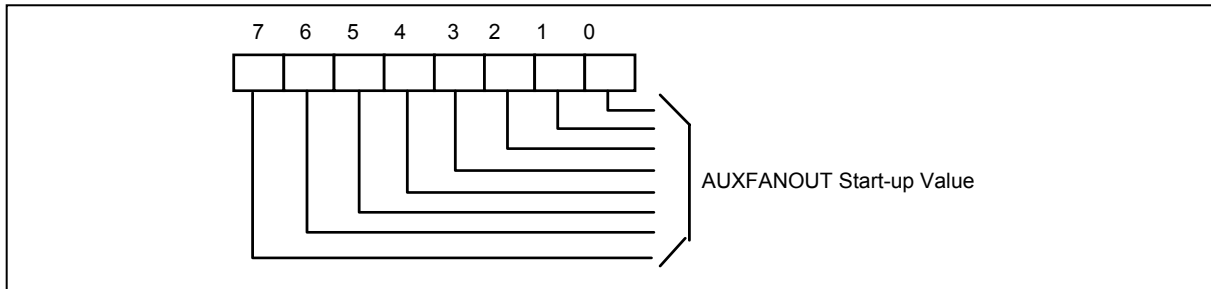

In Thermal Cruise™ mode, the AUXFANOUT value increases from zero to this eight-bit register value to provide a minimum value to turn on the fan.

### 8.26 AUXFANOUT Stop Time Register - Index 17h (Bank 0)

Register Location: 17h  
 Power on Default Value: 3Ch  
 Attribute: Read/Write  
 Size: 8 bits

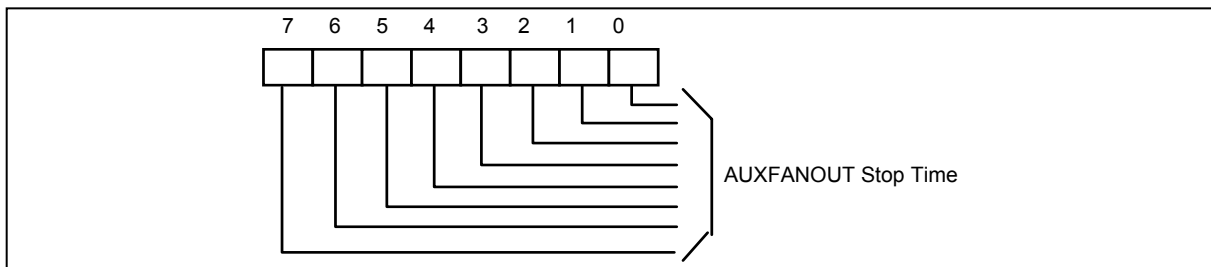

In Thermal Cruise™ mode, if the stop value is enabled, this register determines the amount of time it takes the AUXFANOUT value to fall from the stop value to zero.

- (1) For PWM output,  
The units are intervals of 0.1 second. The default time is 6 seconds.
- (2) For DC output,  
The units are intervals of 0.4 second. The default time is 24 seconds.



**8.27 OVT# Configuration Register - Index 18h (Bank 0)**

Register Location: 18h  
 Power on Default Value: 43h  
 Attribute: Read/Write  
 Size: 8 bits

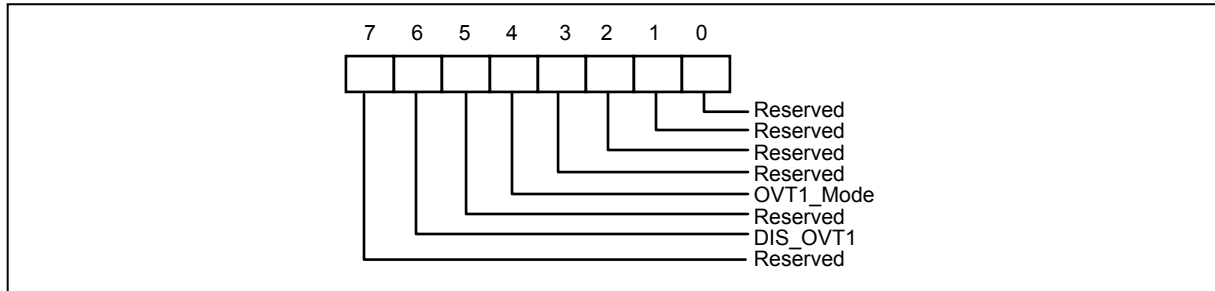

Bit 7: Reserved.

Bit 6:

- 0: Enable SYSTIN OVT# output. (Default)
- 1: Disable temperature sensor SYSTIN over-temperature (OVT#) output.

Bit 5: Reserved.

Bit 4:

- 0: Compare mode. (Default)
- 1: Interrupt mode.

Bit 3-0: Reserved.

**8.28 Reserved Registers - Index 19h ~ 1Fh (Bank 0)**

**8.29 Value RAM — Index 20h ~ 3Fh (Bank 0)**

ADDRESS A6-A0	DESCRIPTION
20h	CPUVCORE reading
21h	VIN0 reading
22h	AVCC reading
23h	3VCC reading
24h	VIN1 reading
25h	VIN2 reading
26h	VIN3 reading
27h	SYSTIN temperature sensor reading
28h	SYSFANIN reading Note: This location stores the number of counts of the internal clock per revolution.
29h	CPUFANIN0 reading Note: This location stores the number of counts of the internal clock per revolution.



Value RAM — Index 20h ~ 3Fh (Bank 0) , continued.

ADDRESS A6-A0	DESCRIPTION
2Ah	AUXFANIN0 reading Note: This location stores the number of counts of the internal clock per revolution.
2Bh	CPUVCORE High Limit
2Ch	CPUVCORE Low Limit
2Dh	VIN0 High Limit
2Eh	VIN0 Low Limit
2Fh	AVCC High Limit
30h	AVCC Low Limit
31h	3VCC High Limit
32h	3VCC Low Limit
33h	VIN1 High Limit
34h	VIN1 Low Limit
35h	VIN2 High Limit
36h	VIN2 Low Limit
37h	VIN3 High Limit
38h	VIN3 Low Limit
39h	SYSTIN temperature sensor High Limit
3Ah	SYSTIN temperature sensor Hysteresis Limit
3Bh	SYSFANIN Fan Count Limit <b>Note:</b> It is the number of counts of the internal clock for the Limit of the fan speed.
3Ch	CPUFANIN0 Fan Count Limit <b>Note:</b> It is the number of counts of the internal clock for the Limit of the fan speed.
3Dh	AUXFANIN0 Fan Count Limit <b>Note:</b> It is the number of counts of the internal clock for the Limit of the fan speed.
3Eh	CPUFANIN1 Fan Count Limit <b>Note:</b> It is the number of counts of the internal clock for the Limit of the fan speed.
3Fh	CPUFANIN1 reading Note: This location stores the number of counts of the internal clock per revolution.



### 8.30 Configuration Register - Index 40h (Bank 0)

Register Location: 40h  
 Power on Default Value: 03h  
 Attribute: Read/Write  
 Size: 8 bits

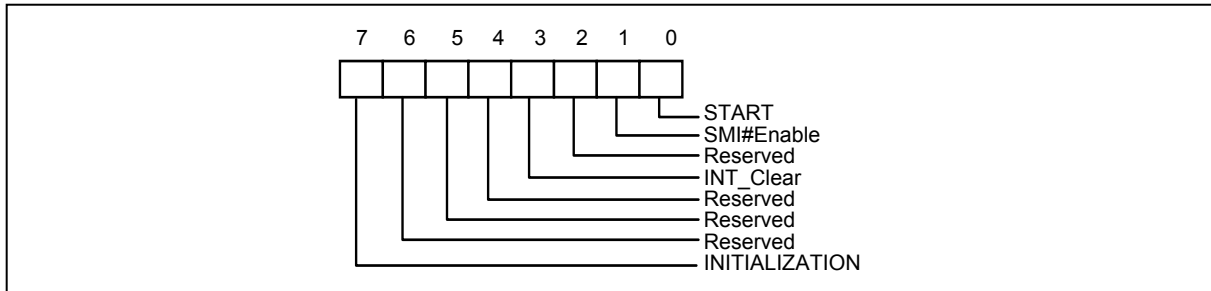

Bit 7: A one restores the power-on default values to some registers. This bit clears itself since the power-on default of this bit is zero.

Bit 6-4: Reserved

Bit 3: A one disables the SMI# output without affecting the contents of Interrupt Status Registers. The device will stop monitoring. It will resume upon clearing of this bit.

Bit 2: Reserved

Bit 1: A one enables the SMI# Interrupt output.

Bit 0: A one enables startup of monitoring operations; a zero puts the part in standby mode.

**Note:** The outputs of Interrupt pins will not be cleared if the user writes a zero to this location after an interrupt has occurred unlike "INT\_Clear" bit.

### 8.31 Interrupt Status Register 1 - Index 41h (Bank 0)

Register Location: 41h  
 Power on Default Value: 00h  
 Attribute: Read Only  
 Size: 8 bits

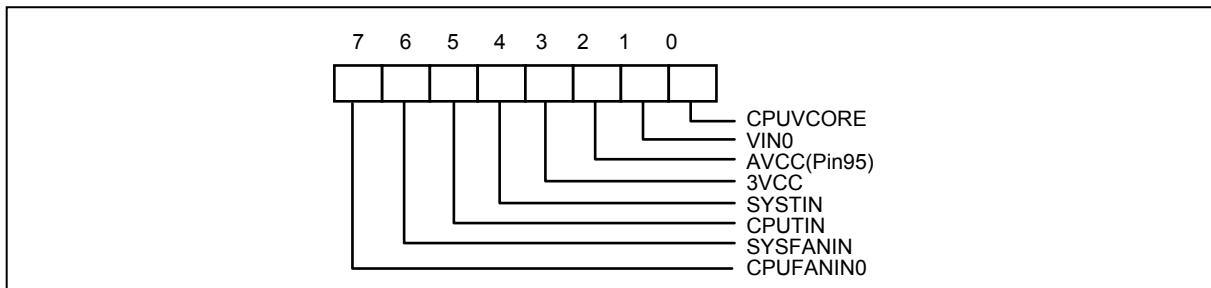

Bit 7: A one indicates the fan count limit of CPUFANIN0 has been exceeded.

Bit 6: A one indicates the fan count limit of SYSFANIN has been exceeded.

Bit 5: A one indicates the high limit of CPUTIN temperature has been exceeded.



Bit 4: A one indicates the high limit of SYSTIN temperature has been exceeded.

Bit 3: A one indicates the high or low limit of 3VCC has been exceeded.

Bit 2: A one indicates the high or low limit of AVCC has been exceeded.

Bit 1: A one indicates the high or low limit of VIN0 has been exceeded.

Bit 0: A one indicates the high or low limit of CPUVCORE has been exceeded.

### 8.32 Interrupt Status Register 2 - Index 42h (Bank 0)

Register Location: 42h  
 Power on Default Value: 00h  
 Attribute: Read Only  
 Size: 8 bits

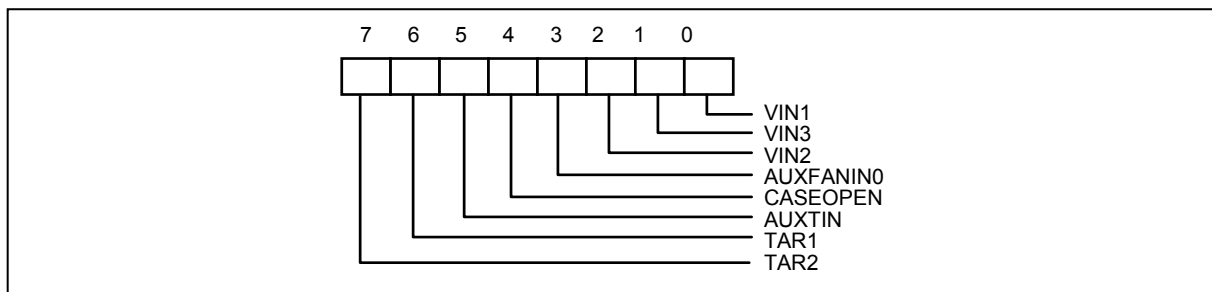

Bit 7: A one indicates that the CPUVIN temperature has been over the target temperature for three minutes at full fan speed in Thermal Cruise™ mode.

Bit 6: A one indicates that the SYSTIN temperature has been over the target temperature for three minutes at full fan speed in Thermal Cruise™ mode.

Bit 5: A one indicates the high limit of AUCTIN temperature has been exceeded.

Bit 4: A one indicates case has been opened.

Bit 3: A one indicates the fan count limit of AUXFANIN0 has been exceeded.

Bit 2: A one indicates the high or low limit of VIN2 has been exceeded.

Bit 1: A one indicates the high or low limit of VIN3 has been exceeded.

Bit 0: A one indicates the high or low limit of VIN1 has been exceeded.



### 8.33 SMI# Mask Register 1 - Index 43h (Bank 0)

Register Location: 43h  
 Power on Default Value: FFh  
 Attribute: Read/Write  
 Size: 8 bits

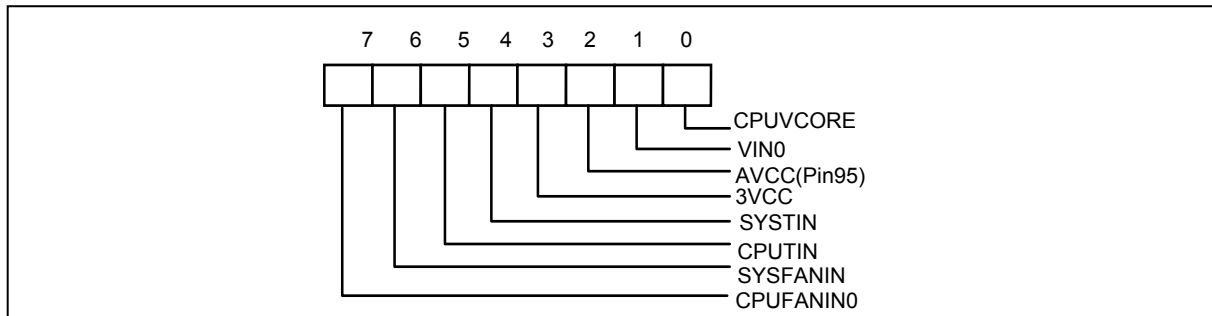

Bit 7-0: A one disables the corresponding interrupt status bit for the  $\overline{\text{SMI}}$  interrupt. (See Interrupt Status Register 1 - Index 41h (Bank 0))

### 8.34 SMI# Mask Register 2 - Index 44h (Bank 0)

Register Location: 44h  
 Power on Default Value: FFh  
 Attribute: Read/Write  
 Size: 8 bits

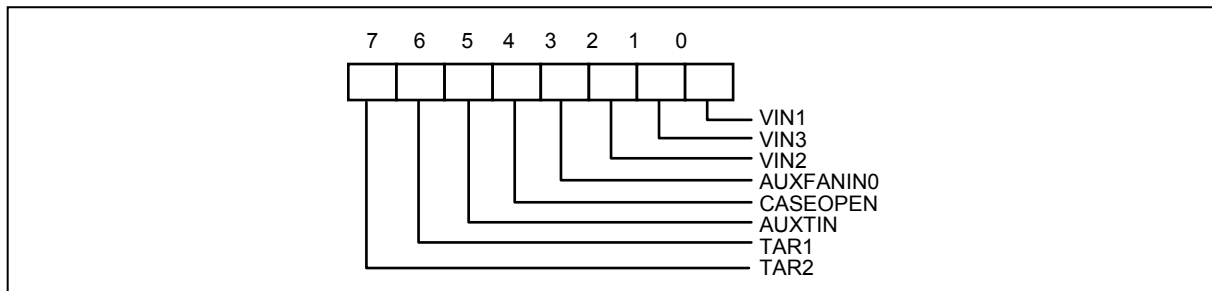

Bit 7-0: A one disables the corresponding interrupt status bit for the  $\overline{\text{SMI}}$  interrupt. (See Interrupt Status Register 2 - Index 42h (Bank 0))

### 8.35 Reserved Register - Index 45h (Bank 0)

### 8.36 SMI# Mask Register 3 - Index 46h (Bank 0)

Register Location: 46h  
 Power on Default Value: 07h  
 Attribute: Read/Write  
 Size: 8 bits

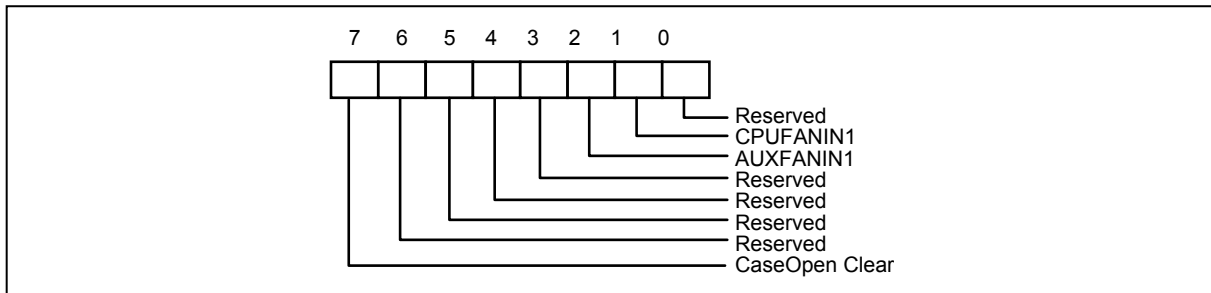

Bit 7: CASEOPEN Clear Control. Write 1 to this bit will clear CASEOPEN status. This bit won't be self cleared, please write 0 after event be cleared. The function is the same as LDA, CR[E6h] bit 5.

Bit 6-3: Reserved.

Bit 2-1: A one disables the corresponding interrupt status bit for the  $\overline{\text{SMI}}$  interrupt. (See Interrupt Status Register 3 - Index 50h (Bank 4))

Bit 0: Reserved.

### 8.37 Fan Divisor Register I - Index 47h (Bank 0)

Register Location: 47h  
 Power on Default Value: 55h  
 Attribute: Read/Write  
 Size: 8 bits

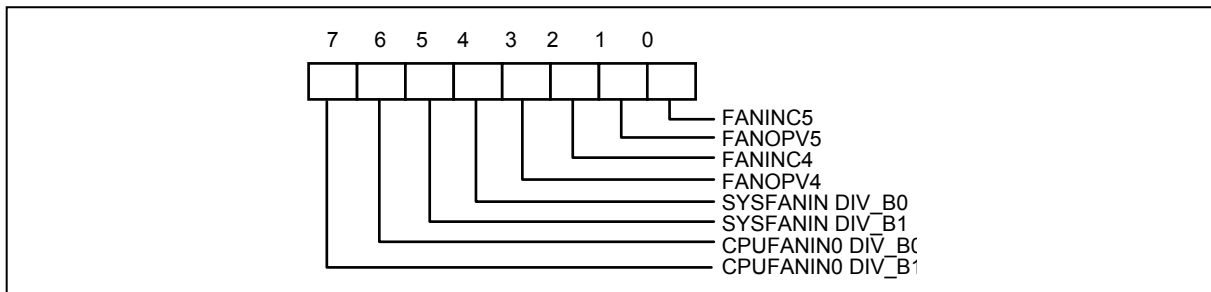

Bit 7-6: CPUFANIN0 Divisor, bits1-0. (See VBAT Monitor Control Register - Index 5Dh (Bank 0))

Bit 5-4: SYSFANIN Divisor, bits1-0. (See VBAT Monitor Control Register - Index 5Dh (Bank 0))

Bit 3: CPUFANIN1 output value, only if bit 2 is set to zero. Otherwise, this bit has no meaning.

1: Pin119(CPUFANIN1) generates a logic-high signal.

0: Pin119 generates a logic-low signal. (Default)

Bit 2: CPUFANIN1 Input Control.

1: Pin119 (CPUFANIN1) acts as a FAN tachometer input. (Default)

0: Pin119 acts as a FAN control signal, and the output value is set by register bit 3.

Bit 1: AUXFANIN1 output value, only if bit 0 is set to zero. Otherwise, this bit has no meaning.

1: Pin58(AUXFANIN1) generates a logic-high signal.

0: Pin58 generates a logic-low signal. (Default)

Bit 0: AUXFANIN1 Input Control.





1: Pin58(AUXFANIN1) acts as a FAN tachometer input. (Default)  
 0, Pin58 acts as a FAN control signal, and the output value is set by bit 1.

**8.38 Serial Bus Address Register - Index 48h (Bank 0)**

Register Location: 48h  
 Power on Default Value: 2Dh  
 Attribute: Read/Write  
 Size: 8 bits

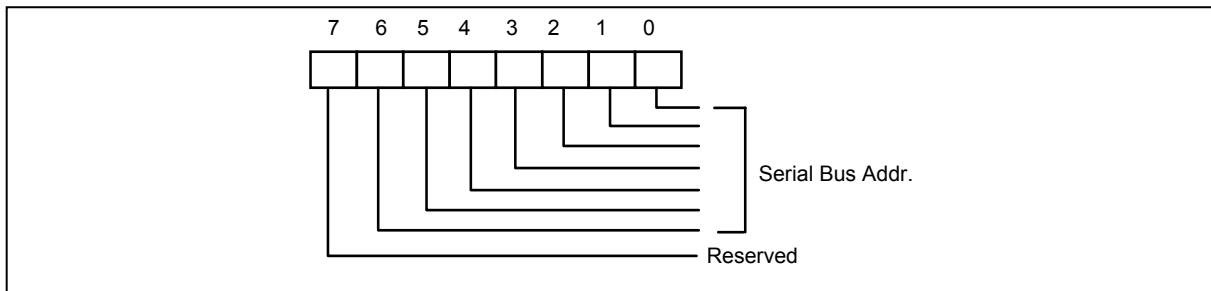

Bit 7: Reserved (read only).  
 Bit 6-0: Serial Bus address <7:1>

**8.39 CPUFANOUT0/AUXFANOUT monitor Temperature source select register - Index 49h (Bank 0)**

Register Location: 49h  
 Power on Default Value: 00h  
 Attribute: Read/Write  
 Size: 8 bits

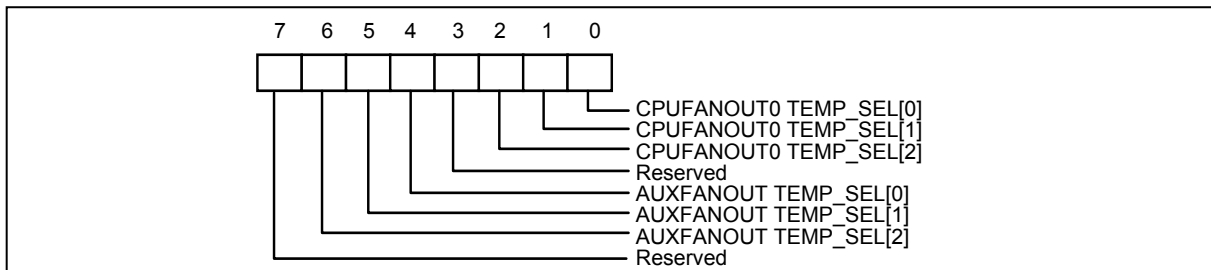

Bit 7: Reserved.  
 Bit 6-4: AUXFANOUT Temperature Source Select  
 000: Select AUXTIN as AUXFANOUT monitor source. (Default)  
 001: Reserved.  
 010: Select PECCI Agent 1 as AUXFANOUT monitor source.  
 011: Select PECCI Agent 2 as AUXFANOUT monitor source.  
 100: Select PECCI Agent 3 as AUXFANOUT monitor source.



101: Select Peci Agent 4 as AUXFANOUT monitor source.

Bit 3: Reserved.

Bit 2-0: CPUFANOUT0 Temperature Source Select

000: Select CPUTIN as CPUFANOUT0 monitor source. (Default)

001: Reserved.

010: Select Peci Agent 1 as CPUFANOUT0 monitor source.

011: Select Peci Agent 2 as CPUFANOUT0 monitor source.

100: Select Peci Agent 3 as CPUFANOUT0 monitor source.

101: Select Peci Agent 4 as CPUFANOUT0 monitor source.

### 8.40 CPUFANOUT1 Monitor Temperature Source Select Register - Index 4Ah (Bank 0)

Register Location: 4Ah  
 Power on Default Value: 00h  
 Attribute: Read/Write  
 Size: 8 bits

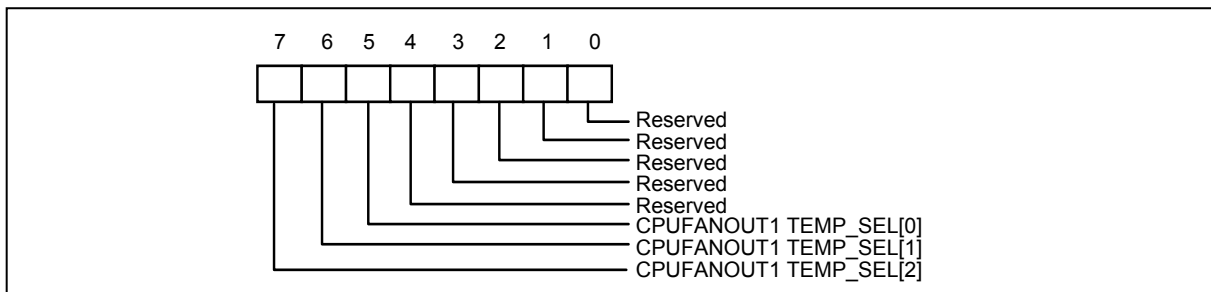

Bit 7-5: CPUFANOUT1 Temperature Source Select

000: Select SYSTIN as CPUFANOUT1 monitor source. (Default)

001: Select CPUTIN as CPUFANOUT1 monitor source.

010: Select AUXTIN as CPUFANOUT1 monitor source.

011: Reserved.

100: Select Peci Agent 1 as CPUFANOUT1 monitor source.

101: Select Peci Agent 2 as CPUFANOUT1 monitor source.

110: Select Peci Agent 3 as CPUFANOUT1 monitor source.

111: Select Peci Agent 4 as CPUFANOUT1 monitor source.

Bit 4-0: Reserved.



**8.41 Fan Divisor Register II - Index 4Bh (Bank 0)**

Register Location: 4Bh  
 Power on Default Value: 44h  
 Attribute: Read/Write  
 Size: 8 bits

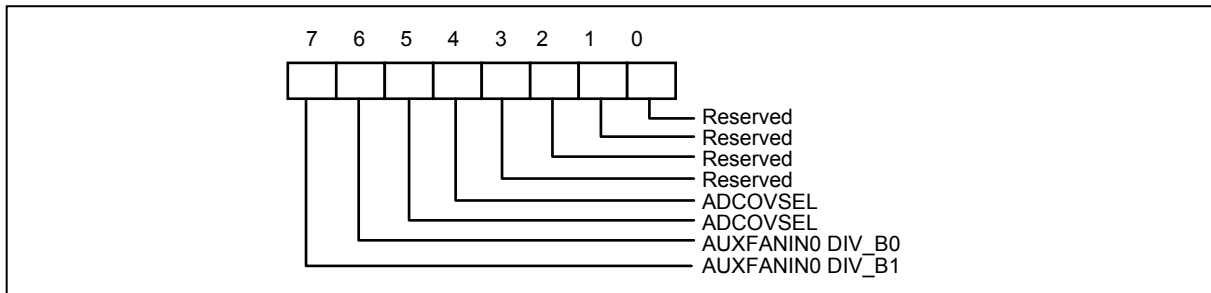

Bit 7-6: AUXFANIN0 Divisor bits1-0.

Note: Please see Bank0 Index 5Dh , Fan divisor table.

Bit 5-4: A/D Converter Clock Input select.

- 00: ADC clock select 22.5 KHz. (Default)
- 01: ADC clock select 5.6 KHz. (22.5K/4)
- 10: ADC clock select 1.4 KHz. (22.5K/16)
- 11: ADC clock select 0.35 KHz. (22.5K/64)

Bit 3-2: Reserved. These two bits should be set to 01h, the default value.

Bit 1-0: Reserved.

**8.42 SMI#/OVT# Control Register - Index 4Ch (Bank 0)**

Register Location: 4Ch  
 Power on Default Value: 10h  
 Attribute: Read/Write  
 Size: 8 bits

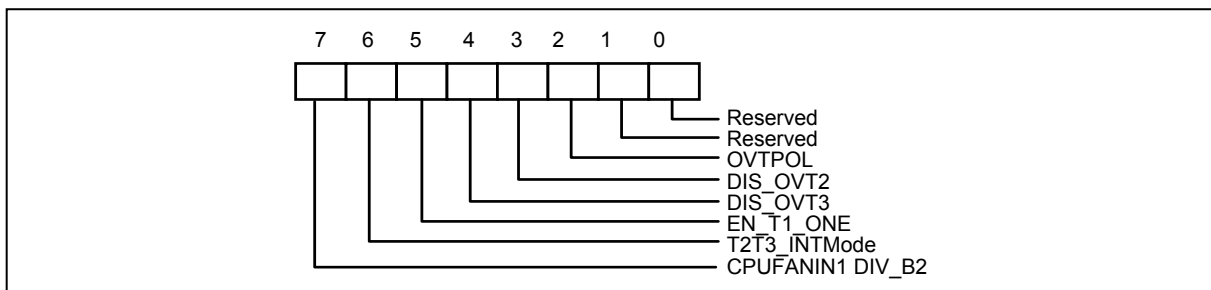

Bit 7: CPUFANIN1 Divisor bit2.

Bit 6:

- 1: SMI# output type of Temperature CPUTIN / AUX TIN is in Comparator Interrupt mode.



- 0: SMI# output type is in Two-Times Interrupt mode. (Default)
- Bit 5:
  - 1: SMI# output type of temperature SYSTIN is One-Time Interrupt mode.
  - 0: SMI# output type is Two-Times Interrupt mode.
- Bit 4:
  - 1: Disable temperature sensor AUX TIN over-temperature (OVT) output. (Default)
  - 0: Enable AUX TIN OVT output through pin OVT#.
- Bit 3:
  - 1: Disable temperature sensor CPU TIN over-temperature (OVT) output.
  - 0: Enable CPU TIN OVT output through pin OVT#. (Default)
- Bit 2: Over-temperature polarity.
  - 1: OVT# active high.
  - 0: OVT# active low. (Default)
- Bit 1-0: Reserved.

**8.43 FAN IN/OUT Control Register - Index 4Dh (Bank 0)**

Register Location: 4Dh  
 Power on Default Value: 95h  
 Attribute: Read/Write  
 Size: 8 bits

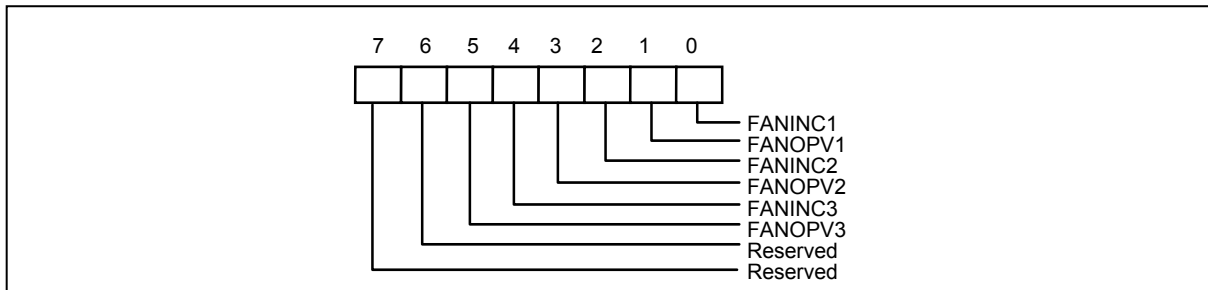

- Bit 7-6: Reserved.
- Bit 5: AUXFANIN0 output value, only if bit 4 is set to zero.
  - 1: Pin111 (AUXFANIN0) generates a logic-high signal.
  - 0: Pin111 generates a logic-low signal. (Default)
- Bit 4: AUXFANIN0 Input Control.
  - 1: Pin111 (AUXFANIN0) acts as a FAN tachometer input. (Default)
  - 0: Pin111 acts as a FAN control signal, and the output value is set by bit 5.
- Bit 3: CPUFANIN0 output value, only if bit 2 is set to zero.
  - 1: Pin112 (CPUFANIN0) generates a logic-high signal.
  - 0: Pin112 generates a logic-low signal. (Default)
- Bit 2: CPUFANIN0 Input Control.
  - 1: Pin112 (CPUFANIN0) acts as a FAN tachometer input. (Default)
  - 0: Pin112 acts as a FAN control signal, and the output value is set by bit 3.



Bit 1: SYSFANIN output value, only if bit 0 is set to zero.

1: Pin113 (SYSFANIN) generates a logic-high signal.

0: Pin113 generates a logic-low signal. (Default)

Bit 0: SYSFANIN Input Control.

1: Pin113 (SYSFANIN) acts as a FAN tachometer input. (Default)

0: Pin113 acts as a FAN control signal, and the output value is set by bit 1.

#### 8.44 Register 50h ~ 5Fh Bank Select Register - Index 4Eh (Bank 0)

Register Location: 4Eh  
 Power on Default Value: 80h  
 Attribute: Read/Write  
 Size: 8 bits

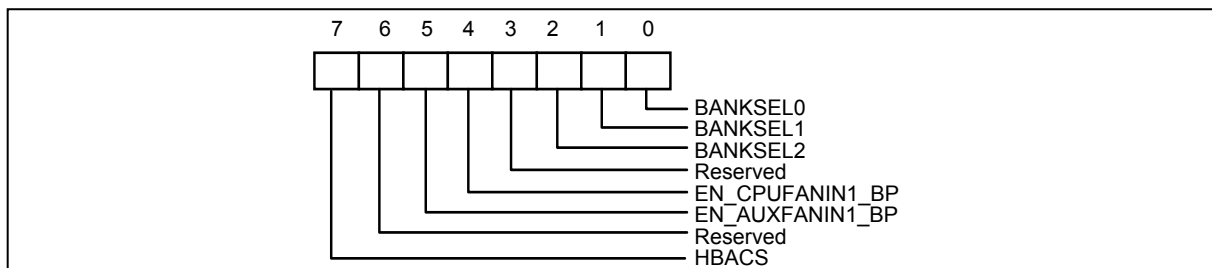

Bit 7: HBACS - High byte access.

1: Access Index 4Fh high-byte register. (Default)

0: Access Index 4Fh low-byte register.

Bit 6: Reserved. This bit should be set to zero.

Bit 5: BEEP output control for AUXFANIN1 if the monitored value exceeds the threshold value.

1: Enable BEEP output.

0: Disable BEEP output. (Default)

Bit 4: BEEP output control for CPUFANIN1 if the monitored value exceeds the threshold value.

1: Enable BEEP output.

0: Disable BEEP output. (Default)

Bit 3: Reserved. This bit should be set to zero.

Bit 2-0: Bank Select for Index Ports 0x50h~0x5Fh. The three-bit binary value corresponds to the bank number. For example, "010" selects bank2.

#### 8.45 Winbond Vendor ID Register - Index 4Fh (Bank 0)

Register Location: 4Fh  
 Power on Default Value: <15:0> = 5CA3h  
 Attribute: Read Only  
 Size: 16 bits

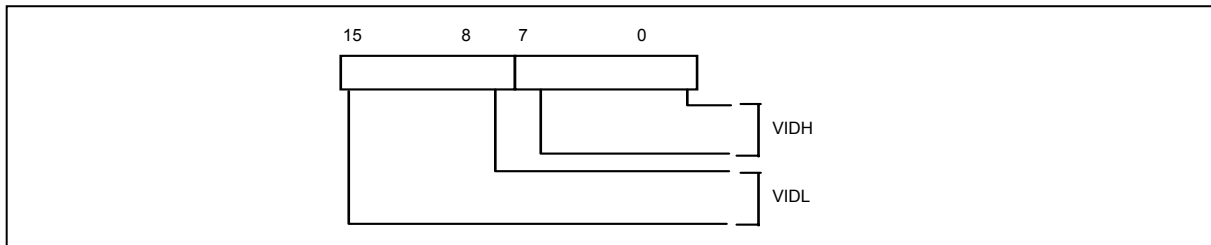

Bit 15-8: Vendor ID High-Byte, if Index 4Eh, bit 7 is 1. Default 5Ch.

Bit 7-0: Vendor ID Low Byte, if Index 4Eh, bit 7 is 0. Default A3h.

**8.46 Reserved Register - Index 50h ~ 55h (Bank 0)**

**8.47 BEEP Control Register 1 - Index 56h (Bank 0)**

Register Location: 56h  
 Power on Default Value: 00h  
 Attribute: Read/Write  
 Size: 8 bits

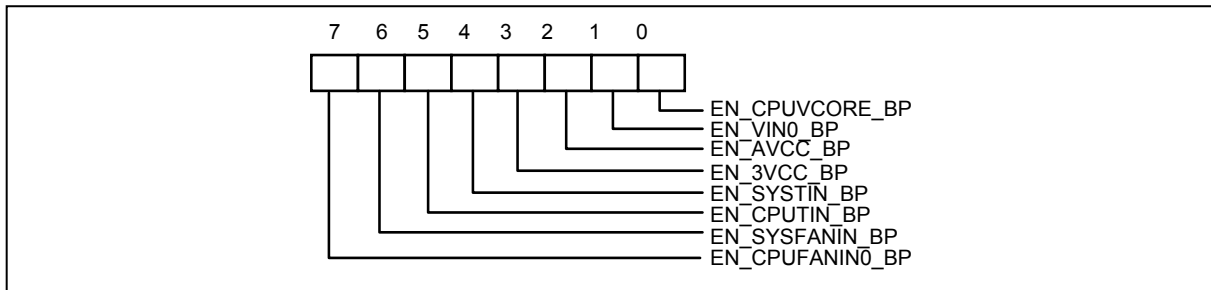

Bit 7: BEEP output control for CPUFANIN0 if the monitored value exceeds the threshold value.  
 1: Enable BEEP output.  
 0: Disable BEEP output. (Default)

Bit 6: BEEP output control for SYSFANIN if the monitored value exceeds the threshold value.  
 1: Enable BEEP output.  
 0: Disable BEEP output. (Default)

Bit 5: BEEP output control for temperature CPUTIN if the monitored value exceeds the threshold value.  
 1: Enable BEEP output.  
 0: Disable BEEP output. (Default)

Bit 4: BEEP output control for temperature SYSTIN if the monitored value exceeds the threshold value.  
 1: Enable BEEP output.  
 0: Disable BEEP output. (Default)

Bit 3: BEEP output control for 3VCC if the monitored value exceeds the threshold value.  
 1: Enable BEEP output.  
 0: Disable BEEP output. (Default)

Bit 2: BEEP output control for AVCC if the monitored value exceeds the threshold value.



- 1: Enable BEEP output.
- 0: Disable BEEP output. (Default)
- Bit 1: BEEP output control for VIN0 if the monitored value exceeds the threshold value.
  - 1: Enable BEEP output.
  - 0: Disable BEEP output. (Default)
- Bit 0: BEEP output control for CPUVCORE if the monitored value exceeds the threshold value.
  - 1: Enable BEEP output.
  - 0: Disable BEEP output. (Default)

**8.48 BEEP Control Register 2 - Index 57h (Bank 0)**

Register Location: 57h  
 Power on Default Value: 80h  
 Attribute: Read/Write  
 Size: 8 bits

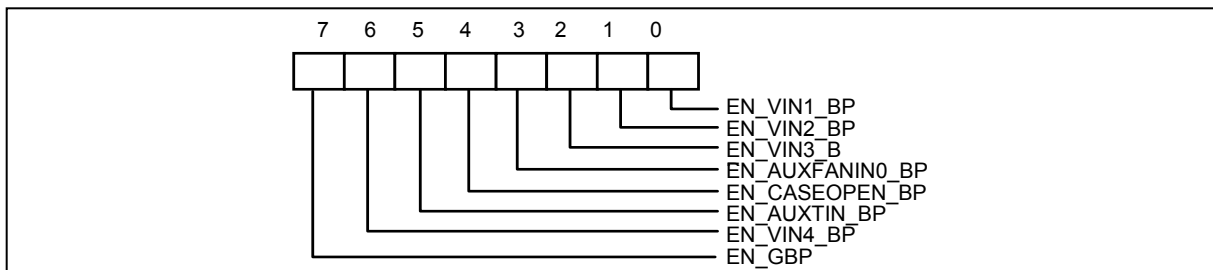

- Bit 7: Global BEEP Control.
  - 1: Enable global BEEP output. (Default)
  - 0: Disable all BEEP output.
- Bit 6: BEEP output control for VIN4 if the monitor value exceeds the limit value.
  - 1: Enable BEEP output.
  - 0: Disable BEEP output. (Default)
- Bit 5: BEEP output control for temperature AUXTIN if the monitored value exceeds the threshold value.
  - 1: Enable BEEP output.
  - 0: Disable BEEP output. (Default)
- Bit 4: BEEP output control for CASEOPEN if the case has been opened.
  - 1: Enable BEEP output.
  - 0: Disable BEEP output. (Default)
- Bit 3: BEEP output control for AUXFANIN0 if the monitored value exceeds the threshold value.
  - 1: Enable BEEP output.
  - 0: Disable BEEP output. (Default)
- Bit 2: BEEP output control for VIN3 if the monitored value exceeds the threshold value.
  - 1: Enable BEEP output.
  - 0: Disable BEEP output. (Default)
- Bit 1: BEEP output control for VIN2 if the monitored value exceeds the threshold value.
  - 1: Enable BEEP output.



- 0: Disable BEEP output. (Default)
- Bit 0: BEEP output control for VIN1 if the monitored value exceeds the threshold value.
  - 1: Enable BEEP output.
  - 0: Disable BEEP output. (Default)

**8.49 Chip ID - Index 58h (Bank 0)**

Register Location: 58h  
 Power on Default Value: C1h  
 Attribute: Read Only  
 Size: 8 bits

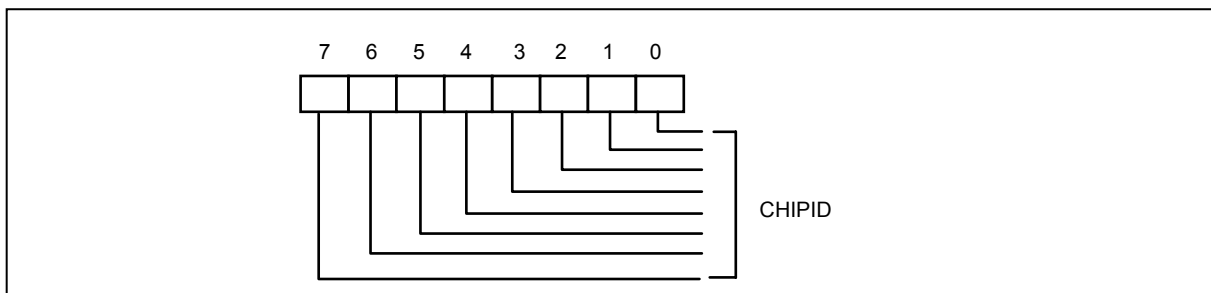

Bit 7-0: Winbond Chip ID number. Default C1h.

**8.50 Diode Selection Register - Index 59h (Bank 0)**

Register Location: 59h  
 Power on Default Value: 70h  
 Attribute: Read/Write  
 Size: 8 bits

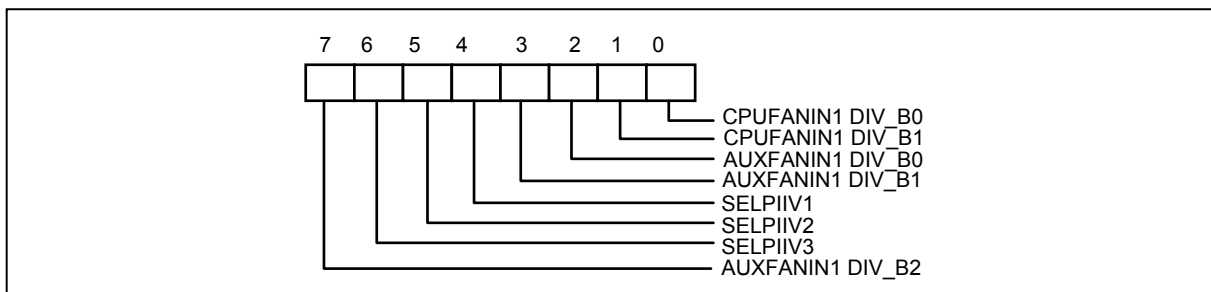

Bit 7: AUXFANIN1 Divisor, bit 2. (See VBAT Monitor Control Register - Index 5Dh (Bank 0))

Bit 6: Diode mode selection for temperature AUCTIN, if Index 5Dh, bit 3 is set to 1.

- 1: CPU-compatible thermal diode.
- 0: Reserved.

Bit 5: Diode mode selection for temperature CPUTIN, if Index 5Dh, bit2 is set to 1.

- 1: CPU-compatible thermal diode.
- 0: Reserved.





Bit 4: Diode mode selection for temperature SYSTIN, if Index 5Dh, bit1 is set to 1.

1: CPU-compatible thermal diode.

0: Reserved.

Bit 3-2: AUXFANIN1 Divisor, bits 1-0. (See VBAT Monitor Control Register - Index 5Dh (*Bank 0*))

Bit 1-0: CPUFANIN1 Divisor, bits 1-0. (See VBAT Monitor Control Register - Index 5Dh (*Bank 0*))

**8.51 Reserved Register - Index 5Ah ~ 5Ch (Bank 0)**

**8.52 VBAT Monitor Control Register - Index 5Dh (Bank 0)**

Register Location: 5Dh

Power on Default Value: 04h

Attribute: Read/Write

Size: 8 bits

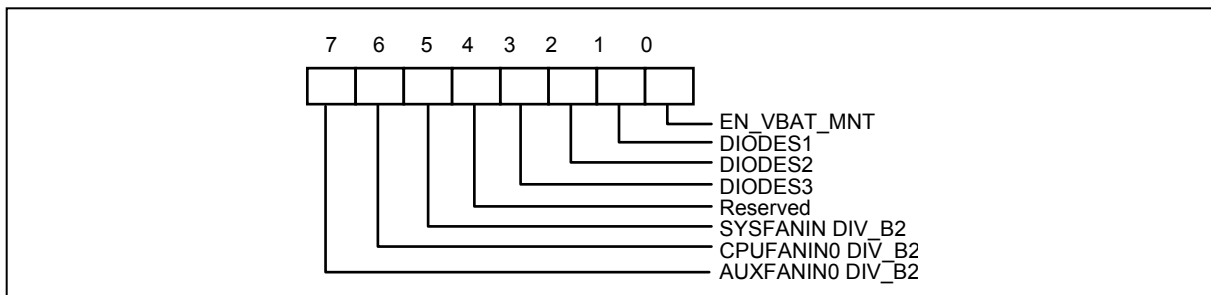

Bit 7: AUXFANIN0 Divisor, bit 2.

Bit 6: CPUFANIN0 Divisor, bit 2.

Bit 5: SYSFANIN Divisor, bit 2.

**Fan divisor table:**

BIT 2	BIT 1	BIT 0	FAN DIVISOR	BIT 2	BIT 1	BIT 0	FAN DIVISOR
0	0	0	1	1	0	0	16
0	0	1	2	1	0	1	32
0	1	0	4	1	1	0	64
0	1	1	8	1	1	1	128

Bit 4: Reserved.

Bit 3: Sensor type selection for AUXTIN.

1: Diode sensor.

0: Thermistor sensor.

Bit 2: Sensor type selection for CPUTIN.

1: Diode sensor.

0: Thermistor sensor.

Bit 1: Sensor type selection for SYSTIN.

1: Diode sensor.

0: Thermistor sensor.



Bit 0:

- 1: Enable battery voltage monitor. When this bit changes from zero to one, it takes one monitor cycle time to update the VBAT reading value register.
- 0: Disable battery voltage monitor.

### 8.53 Critical Temperature and Current Mode Enable Register - Index 5Eh (Bank 0)

Register Location: 5Eh  
 Power on Default Value: 04h  
 Attribute: Read/Write  
 Size: 8 bits

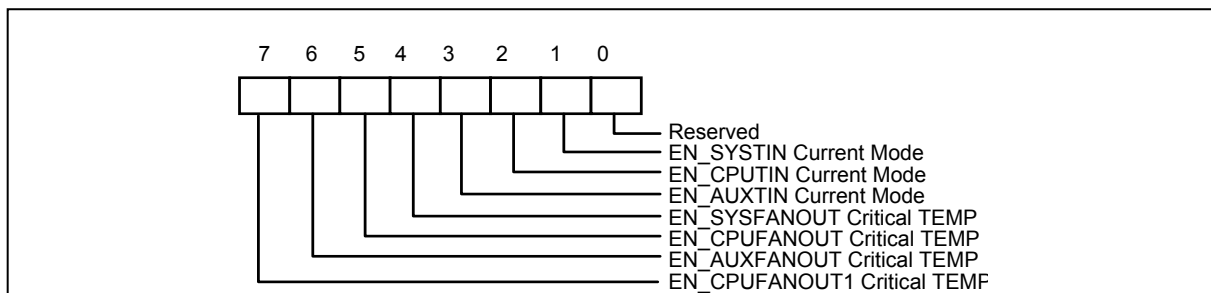

Bit 7:

- 1: Enable CPUFANOUT1 critical temperature protection.
- 0: Disable CPUFANOUT1 critical temperature protection. (Default)

Bit 6:

- 1: Enable AUXFANOUT critical temperature protection.
- 0: Disable AUXFANOUT critical temperature protection. (Default)

Bit 5:

- 1: Enable CPUFANOUT0 critical temperature protection.
- 0: Disable CPUFANOUT0 critical temperature protection. (Default)

Bit 4:

- 1: Enable SYSFANOUT critical temperature protection.
- 0: Disable SYSFANOUT critical temperature protection. (Default)

Bit 3: Enable AUXTIN Current Mode.

- 1: Temperature sensing of AUXTIN by Current Mode.
- 0: Temperature sensing of AUXTIN depends on the setting of Index 5Dh and 59h. (Default)

Bit 2: Enable CPUTIN Current Mode.

- 1: Temperature sensing of CPUTIN by Current Mode. (Default)
- 0: Temperature sensing of CPUTIN depends on the setting of Index 5Dh and 59h.

Bit 1: Enable SYSTIN Current Mode.

- 1: Temperature sensing of SYSTIN by Current Mode.
- 0: Temperature sensing of SYSTIN depends on the setting of Index 5Dh and 59h. (Default)

Bit 0: Reserved.



#### 8.54 Reserved Register - Index 5Fh (Bank 0)

#### 8.55 CPUFANOUT1 PWM Output Frequency Configuration Register - Index 60h (Bank 0)

Register Location: 60h  
 Power on Default Value: 04h  
 Attribute: Read/Write  
 Size: 8 bits

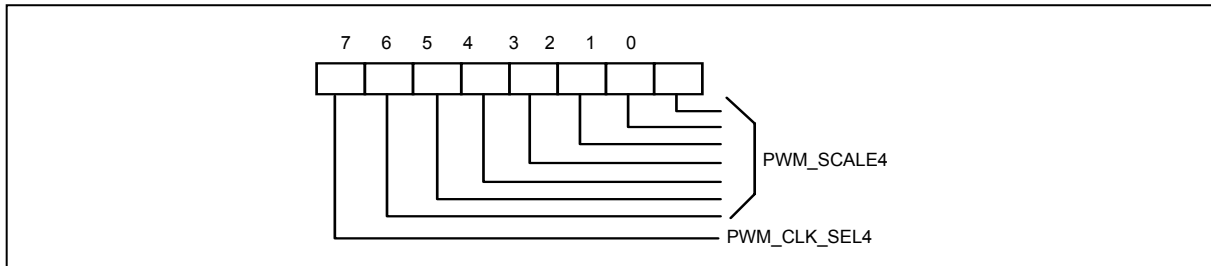

**The register is only meaningful when CPUFANOUT1 is programmed for PWM output.**

Bit 7: CPUFANOUT1 PWM Input Clock Source Select. This bit selects the clock source for PWM output.

0: clock source is 24 MHz.

1: clock source is 180 KHz.

Bit 6-0: CPUFANOUT1 PWM Pre-Scale divider. The clock source of PWM output is divided by this seven-bit value to calculate the actual PWM output frequency.

$$\text{PWM output frequency} = \frac{\text{Input Clock}}{\text{Pre\_Scale Divider}} * \frac{1}{256}$$

The maximum value of the divider is 127 (7Fh), and it should not be set to 0.

#### 8.56 CPUFANOUT1 Output Value Select Register - Index 61h (Bank 0)

Register Location: 61h  
 Power on Default Value: Strap by FAN\_SET2(Pin 83)  
 Attribute: Read/Write  
 Size: 8 bits

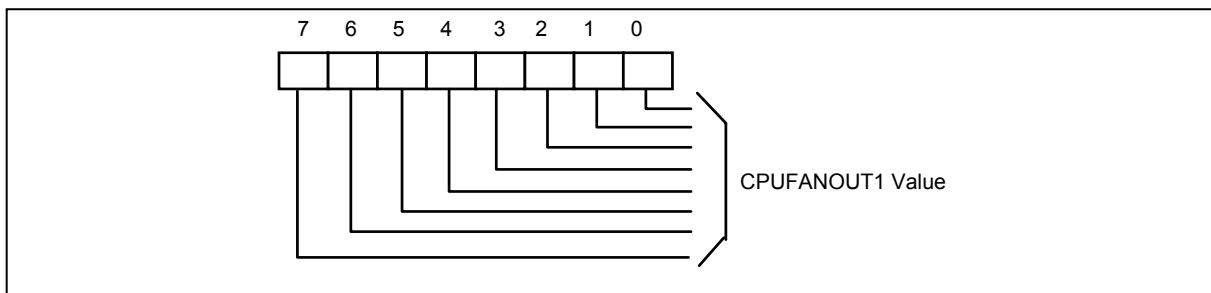



**(1) If CPUFANOUT1 is programmed for PWM output (Bank0 Index 62h, bit 6 is 0)**

Bit 7-0: CPUFANOUT1 PWM Duty Cycle. The PWM duty cycle is equal to this eight-bit value, divided by 255, times 100%. FFh creates a duty cycle of 100%, and 00h creates a duty cycle of 0%.

**(2) If CPUFANOUT1 is programmed for DC output (Bank0 Index 62h, bit 6 is 1)**

Bit 7-2: CPUFANOUT1 voltage control. The output voltage is calculated according to this equation.

$$\text{OUTPUT Voltage} = AVCC * \frac{FANOUT}{64}$$

Bit 1-0: Reserved.

### 8.57 FAN Configuration Register III - Index 62h (Bank 0)

Register Location: 62h  
 Power on Default Value: 40h  
 Attribute: Read/Write  
 Size: 8 bits

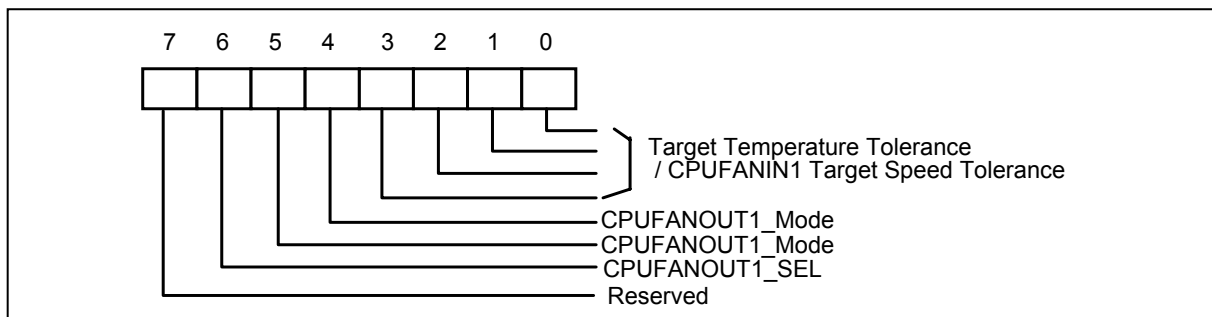

Bit 7: Reserved.

Bit 6: CPUFANOUT1 output mode selection.

0: CPUFANOUT1 pin produces a PWM output duty cycle.

1: CPUFANOUT1 pin produces DC output. (Default)

Bit 5-4: CPUFANOUT1 mode control.

Set 00, CPUFANOUT1 is in Manual Mode. (Default)

Set 01, CPUFANOUT1 is in Thermal Cruise™ Mode.

Set 10, CPUFANOUT1 is in Fan Speed Cruise™ Mode.

Set 11, CPUFANOUT1 is in SMART FAN™ III Mode.

(1) In Thermal Cruise™ mode or SMART FAN™ III mode:

Bit 3-0: Tolerance of select temperature source Target Temperature.

(2) In Fan Speed Cruise™ mode:

Bit 3-0: Tolerance of CPUFANIN1 Target Speed.



### 8.58 Target Temperature Register/CPUFANIN1 Target Speed Register - Index 63h (Bank 0)

Register Location: 63h  
 Power on Default Value: 00h  
 Attribute: Read/Write  
 Size: 8 bits

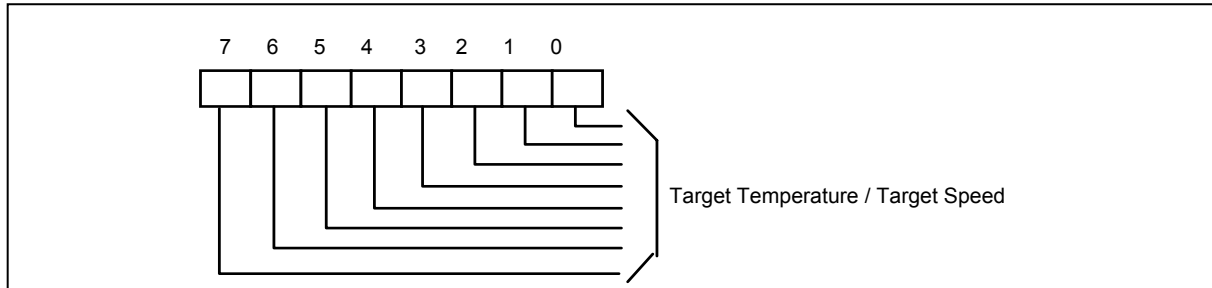

(1) In Thermal Cruise™ mode or SMART FAN™ III mode:  
 Bit 7: Reserved.  
 Bit 6-0: Target Temperature of select temperature source.

(2) In Fan Speed Cruise™ mode:  
 Bit 7-0: CPUFANIN1 Target Speed.

### 8.59 CPUFANOUT1 Stop Value Register - Index 64h (Bank 0)

Register Location: 64h  
 Power on Default Value: 01h  
 Attribute: Read/Write  
 Size: 8 bits

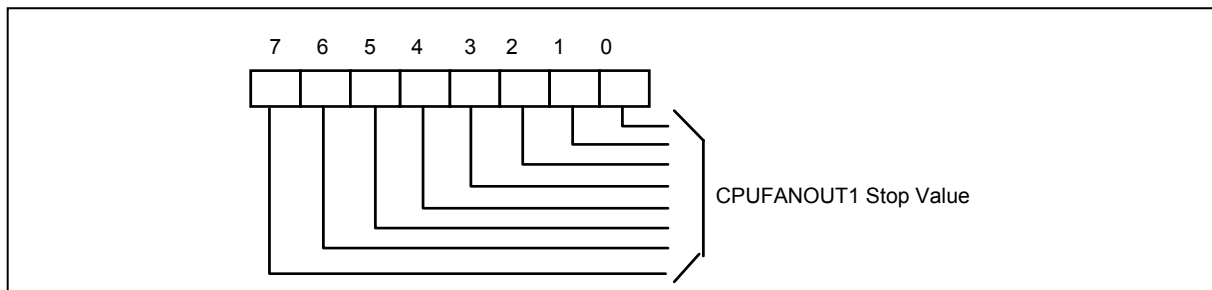

In Thermal Cruise™ mode, the CPUFANOUT1 value decreases to this eight-bit value if the temperature stays below the lowest temperature limit. This value should not be zero.

Please note that Stop Value does not mean that the fan really stops. It means that if the temperature keeps below low temperature limit, then the fan speed keeps on decreasing until reaching a minimum value, and this is Stop Value.



### 8.60 CPUFANOUT1 Start-up Value Register - Index 65h (Bank 0)

Register Location: 65h  
 Power on Default Value: 01h  
 Attribute: Read/Write  
 Size: 8 bits

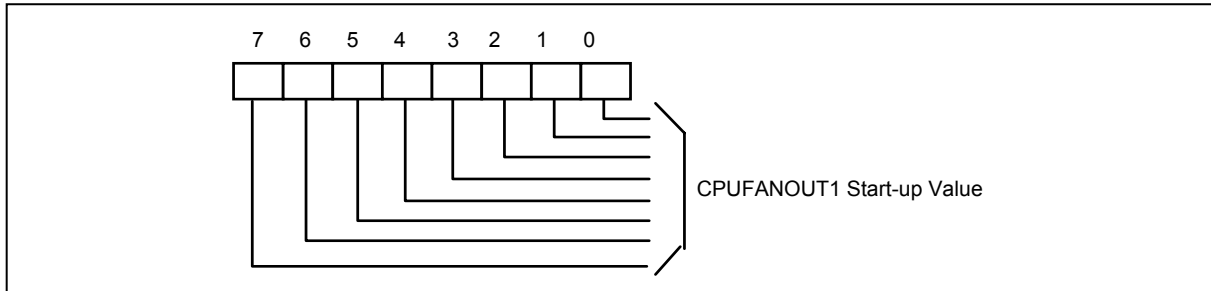

In Thermal Cruise™ mode, CPUFANOUT1 value increases from zero to this eight-bit register value to provide a minimum value to turn on the fan.

### 8.61 CPUFANOUT1 Stop Time Register - Index 66h (Bank 0)

Register Location: 66h  
 Power on Default Value: 3Ch  
 Attribute: Read/Write  
 Size: 8 bits

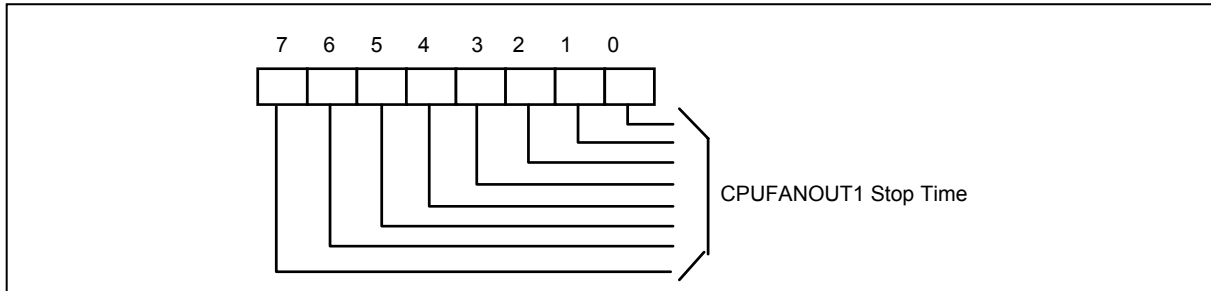

In Thermal Cruise™ mode or SMART FAN™ III mode, if the stop value is enabled, this register determines the amount of time it takes the CPUFANOUT1 value to fall from the stop value to zero.

(1)For PWM output:

The units are intervals of 0.1 second. The default time is 6 seconds.

(2)For DC output:

The units are intervals of 0.4 second. The default time is 24 seconds.



**8.62 CPUFANOUT0 Maximum Output Value Register - Index 67h (Bank 0)**

Register Location: 67h  
 Power on Default Value: FFh  
 Attribute: Read/Write  
 Size: 8 bits

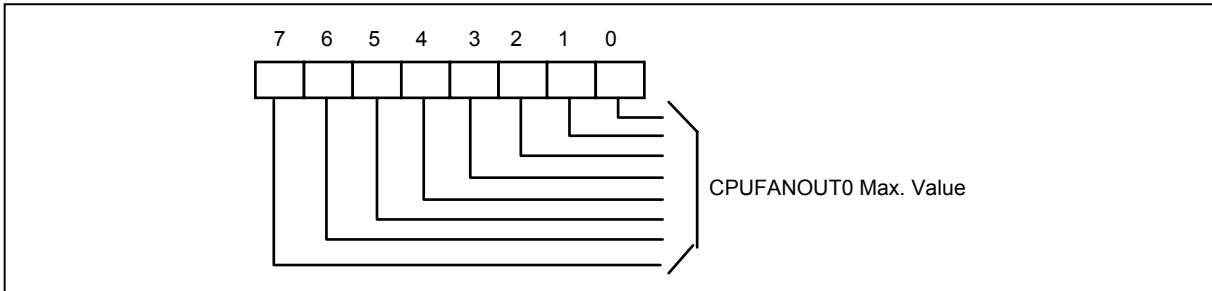

In SMART FAN™ III mode, the CPUFANOUT0 value increases to this value. This value cannot be zero, and it cannot be lower than the CPUFANOUT0 Stop value.

**8.63 CPUFANOUT0 Output Step Value Register - Index 68h (Bank 0)**

Register Location: 68h  
 Power on Default Value: 01h  
 Attribute: Read/Write  
 Size: 8 bits

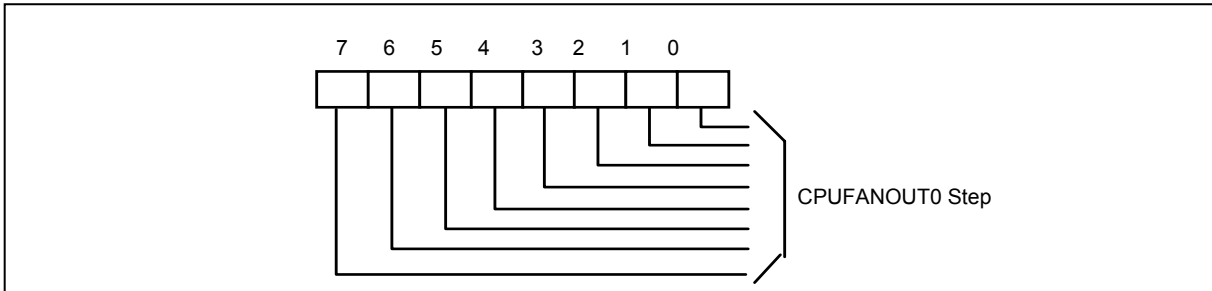

In SMART FAN™ III mode, the CPUFANOUT0 value decreases or increases by this eight-bit value, when needed.



**8.64 CPUFANOUT1 Maximum Output Value Register - Index 69h (Bank 0)**

Register Location: 69h  
 Power on Default Value: FFh  
 Attribute: Read/Write  
 Size: 8 bits

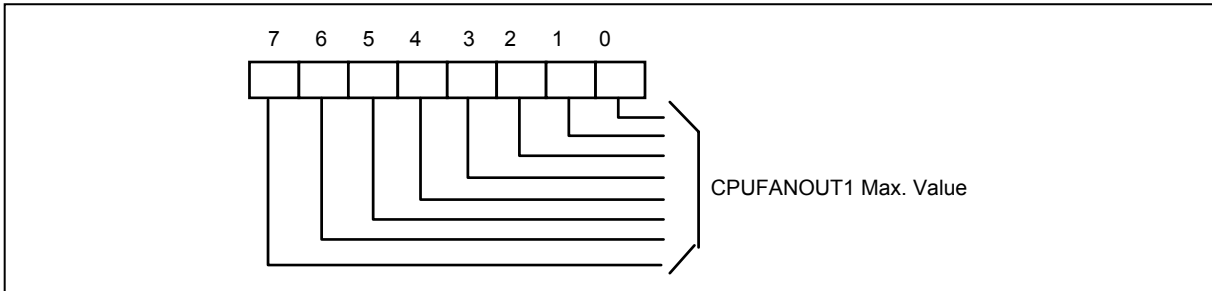

In SMART FAN™ III mode, the CPUFANOUT1 value increases to this value. This value cannot be zero, and it cannot be lower than the CPUFANOUT1 Stop value.

**8.65 CPUFANOUT1 Output Step Value Register - Index 6Ah (Bank 0)**

Register Location: 6Ah  
 Power on Default Value: 01h  
 Attribute: Read/Write  
 Size: 8 bits

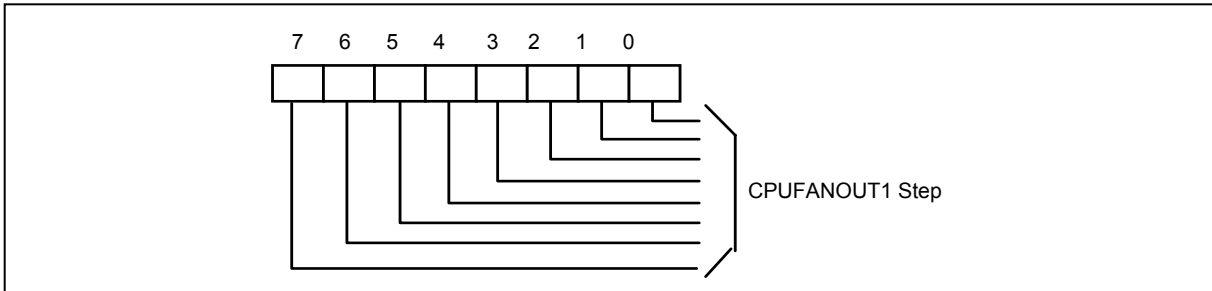

In SMART FAN™ III mode, the CPUFANOUT1 value decreases or increases by this eight-bit value, when needed.





### 8.66 SYSFANOUT Critical Temperature register - Index 6Bh (Bank 0)

Register Location: 6Bh  
 Power on Default Value: FFh  
 Attribute: Read/Write  
 Size: 8 bits

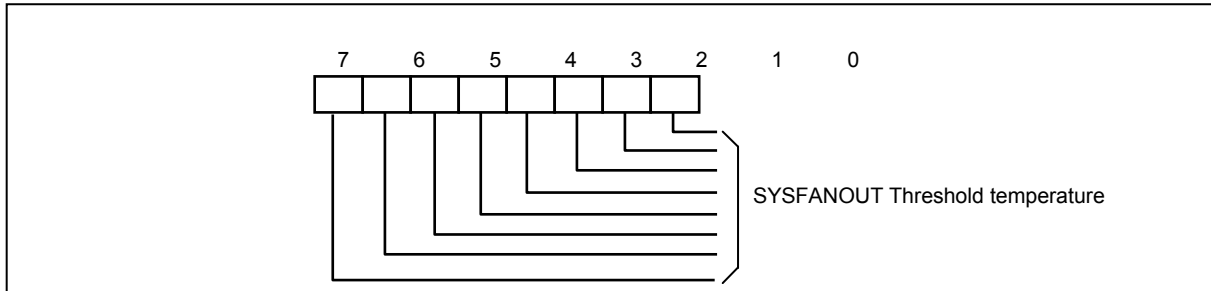

In Thermal Cruise™ mode, when the function of SYSFANOUT temperature sensing is enabled, and the monitored temperature exceeds the threshold temperature, the SYSFANOUT will work at full speed.

### 8.67 CPUFANOUT0 Critical Temperature Register - Index 6Ch (Bank 0)

Register Location: 6Ch  
 Power on Default Value: FFh  
 Attribute: Read/Write  
 Size: 8 bits

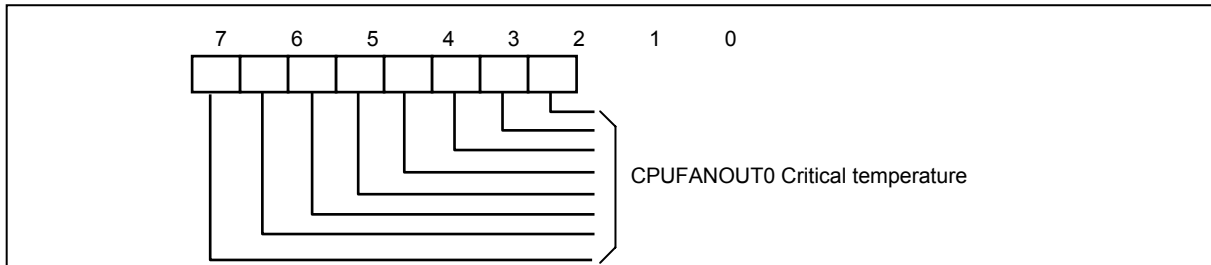

In Thermal Cruise™ mode, when the function of CPUFANOUT0 temperature sensing is enabled, and the monitored temperature exceeds the threshold temperature, the CPUFANOUT0 will work at full speed.

### 8.68 AUXFANOUT Critical Temperature Register - Index 6Dh (Bank 0)

Register Location: 6Dh  
 Power on Default Value: FFh  
 Attribute: Read/Write  
 Size: 8 bits

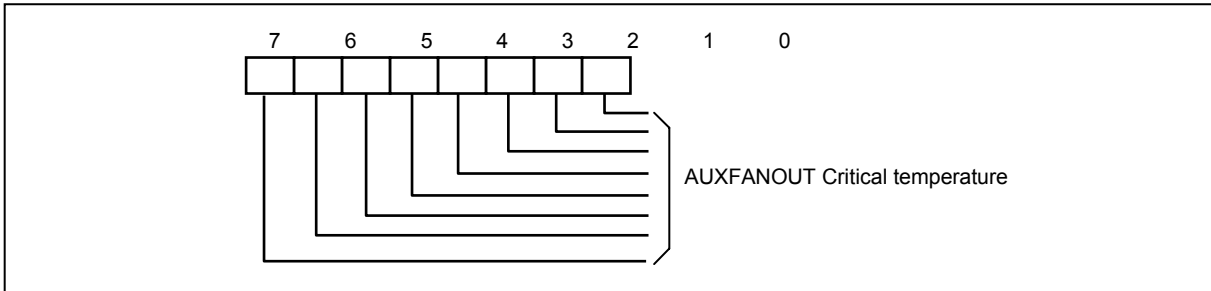

In Thermal Cruise™ mode, when the function of AUXFANOUT temperature sensing is enabled, and the monitored temperature exceeds the threshold temperature, the AUXFANOUT will work at full speed.

**8.69 CPUFANOUT1 Critical Temperature Register - Index 6Eh (Bank 0)**

Register Location: 6Eh  
 Power on Default Value: FFh  
 Attribute: Read/Write  
 Size: 8 bits

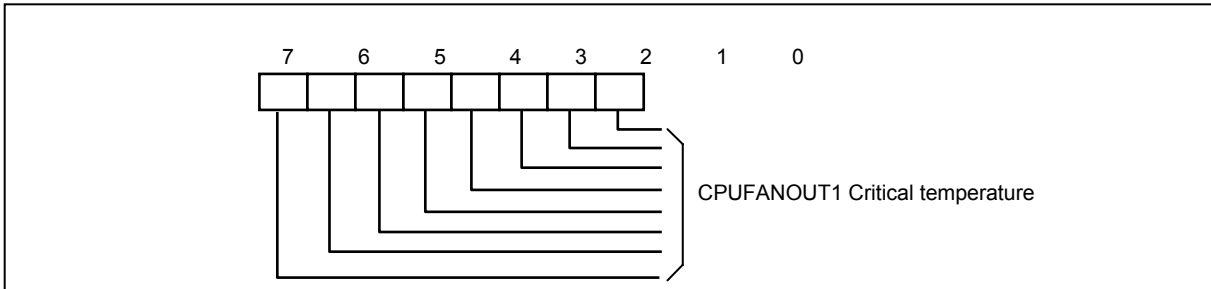

In Thermal Cruise™ mode, when the function of CPUFANOUT1 temperature sensing is enabled, and the monitored temperature exceeds the threshold temperature, the CPUFANOUT1 will work at full speed.

**8.70 CPUTIN Temperature Sensor Temperature (High Byte) Register - Index 50h (Bank 1)**

Register Location: 50h  
 Attribute: Read Only  
 Size: 8 bits

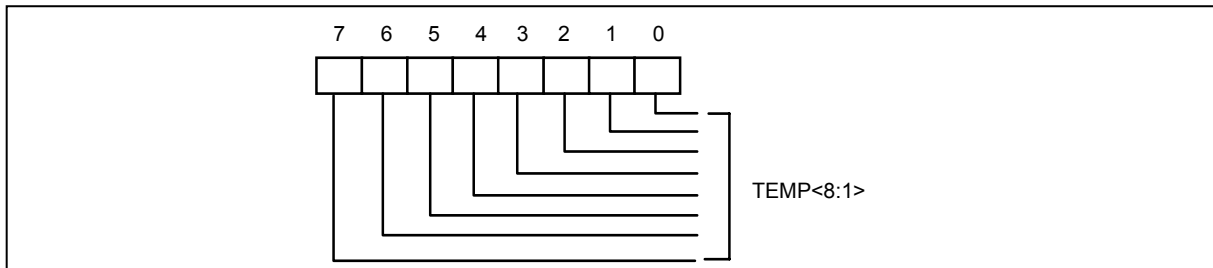

Bit 7-0: Temperature <8:1> of the CPUTIN sensor, The nine-bit value is in units of 0.5°C.

**8.71 CPUTIN Temperature Sensor Temperature (Low Byte) Register - Index 51h (Bank 1)**

Register Location: 51h  
 Attribute: Read Only  
 Size: 8 bits

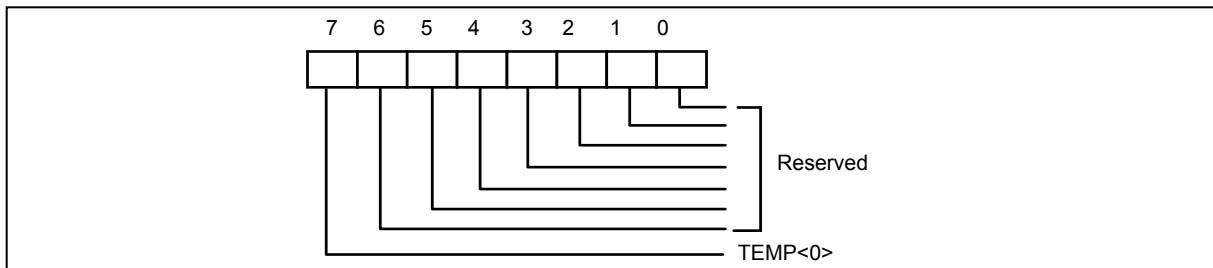

Bit 7: Temperature <0> of the CPUTIN sensor, The nine-bit value is in units of 0.5°C.

Bit 6-0: Reserved.

**8.72 CPUTIN Temperature Sensor Configuration Register - Index 52h (Bank 1)**

Register Location: 52h  
 Power on Default Value: 00h  
 Attribute: Read/Write  
 Size: 8 bits

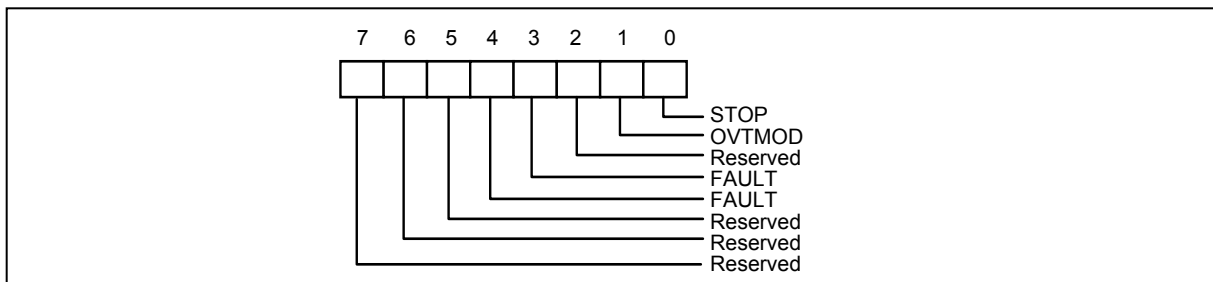

Bit 7-5: Reserved. This bit should be set to zero.

Bit 4-3: Number of faults to detect before setting OVT# output. This avoids false tripping due to noise.



Bit 2: Reserved. This bit should be set to zero.

Bit 1 : OVT# mode select.

0: Compared mode. (Default)

1: Interrupt mode.

Bit 0 : 0: Monitor CPUTIN.

1: Stop monitoring CPUTIN.

**8.73 CPUTIN Temperature Sensor Hysteresis (High Byte) Register - Index 53h (Bank 1)**

Register Location: 53h  
 Power on Default Value: 4Bh  
 Attribute: Read/Write  
 Size: 8 bits

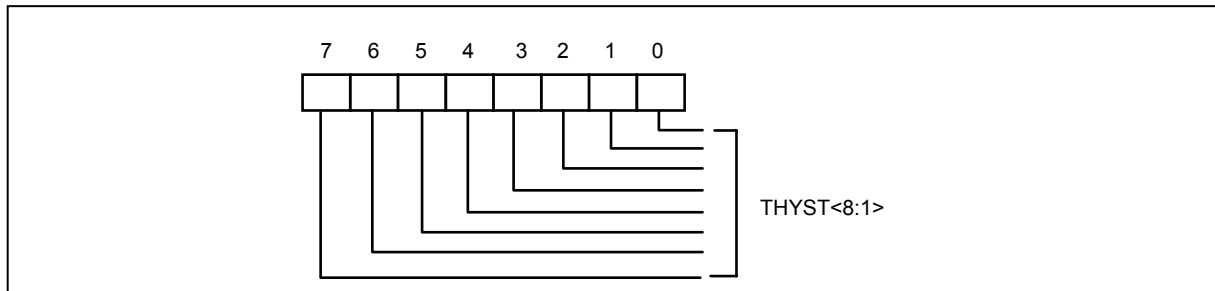

Bit 7-0: Hysteresis temperature bits 8-1. The nine-bit value is in units of 0.5°C, and the default is 75°C.

**8.74 CPUTIN Temperature Sensor Hysteresis (Low Byte) Register - Index 54h (Bank 1)**

Register Location: 54h  
 Power on Default Value: 00h  
 Attribute: Read/Write  
 Size: 8 bits

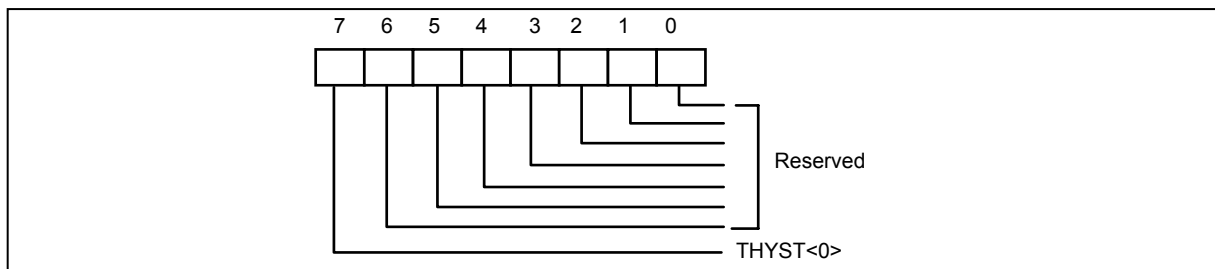

Bit 7: Hysteresis temperature bit 0. The nine-bit value is in units of 0.5°C.

Bit 6-0: Reserved.



**8.75 CPUTIN Temperature Sensor Over-temperature (High Byte) Register - Index 55h (Bank1)**

Register Location: 55h  
 Power on Default Value: 50h  
 Attribute: Read/Write  
 Size: 8 bits

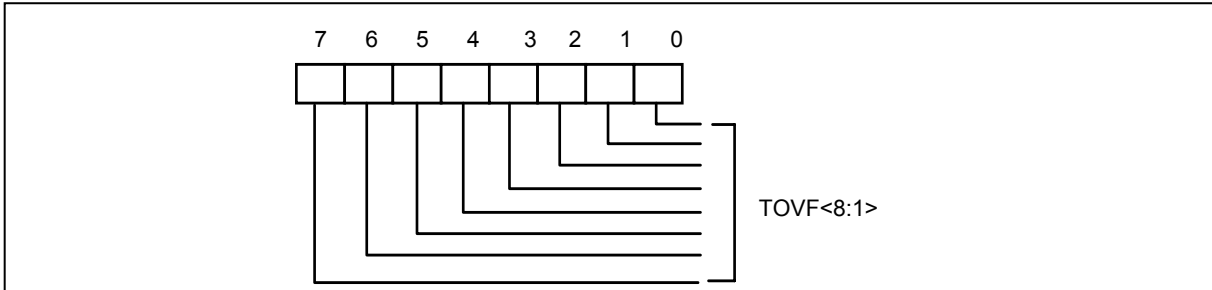

Bit 7-0: Over-temperature bits 8-1. The nine-bit value is in units of 0.5°C, and the default is 80°C.

**8.76 CPUTIN Temperature Sensor Over-temperature (Low Byte) Register - Index 56h (Bank 1)**

Register Location: 56h  
 Power on Default Value: 00h  
 Attribute: Read/Write  
 Size: 8 bits

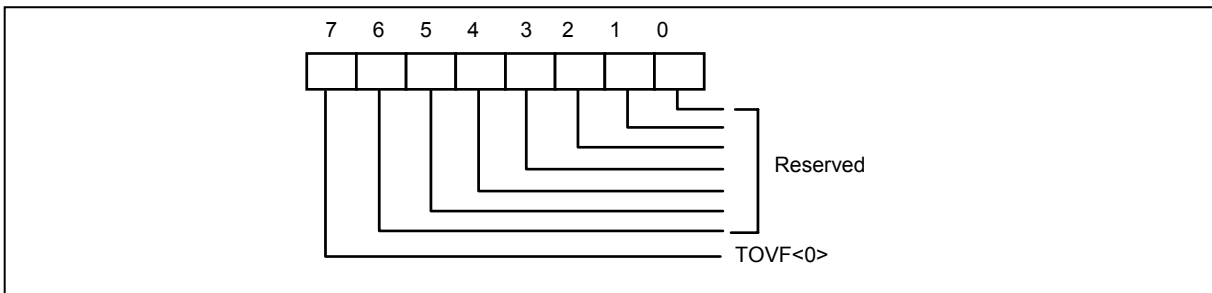

Bit 7: Over-temperature bit 0. The nine-bit value is in units of 0.5°C.

Bit 6-0: Reserved.



### 8.77 AUXTIN Temperature Sensor Temperature (High Byte) Register - Index 50h (Bank 2)

Register Location: 50h  
 Attribute: Read Only  
 Size: 8 bits

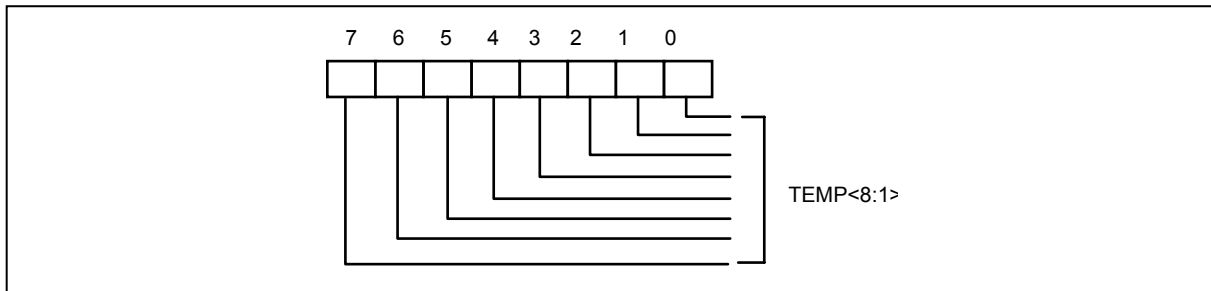

Bit 7: Temperature <8:1> of the AUXTIN sensor. The nine-bit value is in units of 0.5°C.

### 8.78 AUXTIN Temperature Sensor Temperature (Low Byte) Register - Index 51h (Bank 2)

Register Location: 51h  
 Attribute: Read Only  
 Size: 8 bits

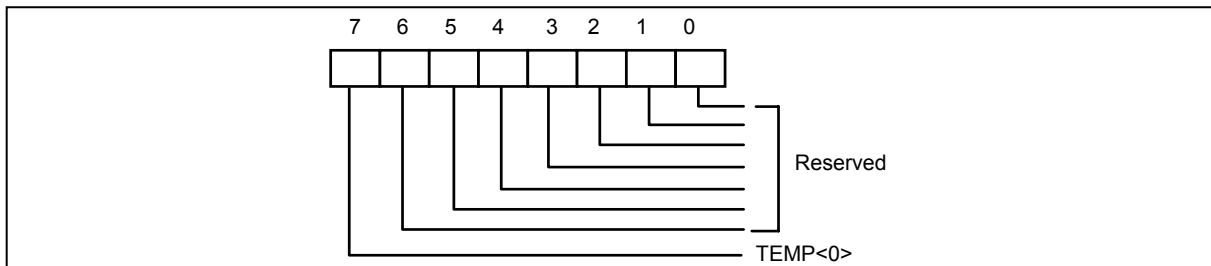

Bit 7: Temperature <0> of the AUXTIN sensor. The nine-bit value is in units of 0.5°C.

Bit 6-0: Reserved.

### 8.79 AUXTIN Temperature Sensor Configuration Register - Index 52h (Bank 2)

Register Location: 52h  
 Power on Default Value: 00h  
 Attribute: Read/Write  
 Size: 8 bits

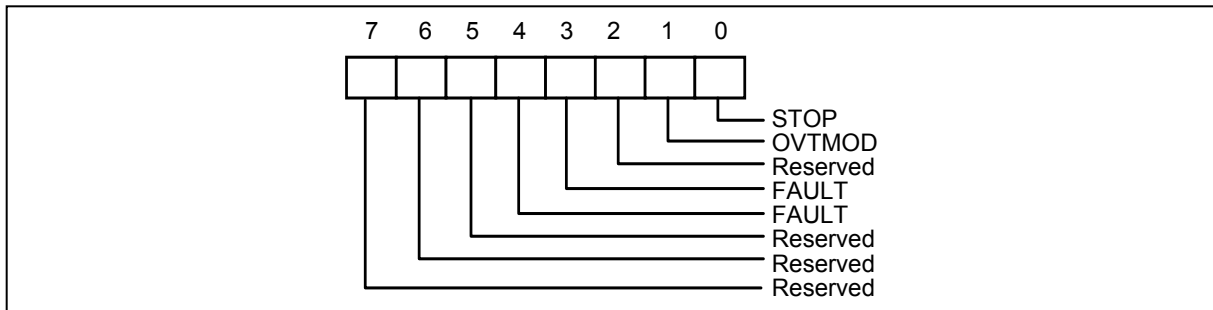

Bit 7-5: Reserved. This bit should be set to zero.

Bit 4-3: Number of faults to detect before setting OVT# output. This avoids false tripping due to noise.

Bit 2: Reserved. This bit should be set to zero.

Bit 1: OVT# mode select.

0: Compared mode. (Default)

1: Interrupt mode.

Bit 0 : 0: Monitor AUXTIN.

1: Stop monitoring AUXTIN.

### 8.80 AUXTIN Temperature Sensor Hysteresis (High Byte) Register - Index 53h (Bank 2)

Register Location: 53h  
Power on Default Value: 4Bh  
Attribute: Read/Write  
Size: 8 bits

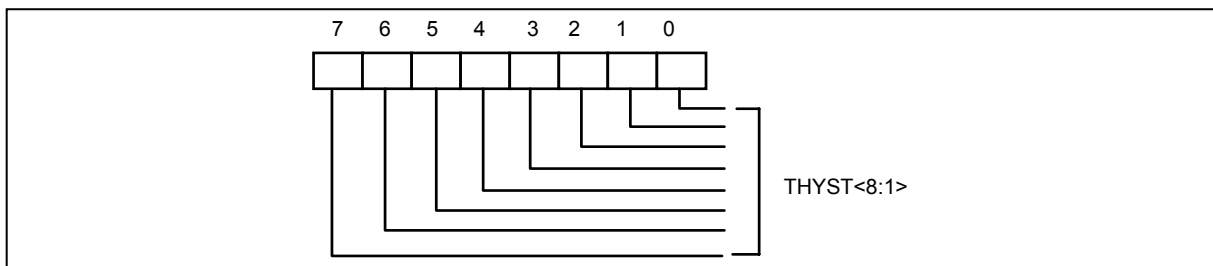

Bit 7-0: Hysteresis temperature, bits 8-1. The nine-bit value is in units of 0.5°C, and the default is 75°C.

### 8.81 AUXTIN Temperature Sensor Hysteresis (Low Byte) Register - Index 54h (Bank 2)

Register Location: 54h  
Power on Default Value: 00h  
Attribute: Read/Write  
Size: 8 bits

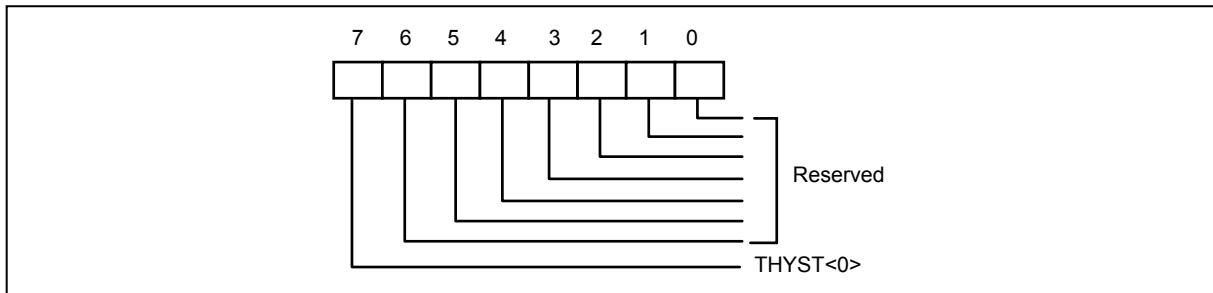

Bit 7: Hysteresis temperature, bit 0. The nine-bit value is in units of 0.5°C.  
 Bit 6-0: Reserved.

**8.82 AUXTIN Temperature Sensor Over-temperature (High Byte) Register - Index 55h (Bank 2)**

Register Location: 55h  
 Power on Default Value: 50h  
 Attribute: Read/Write  
 Size: 8 bits

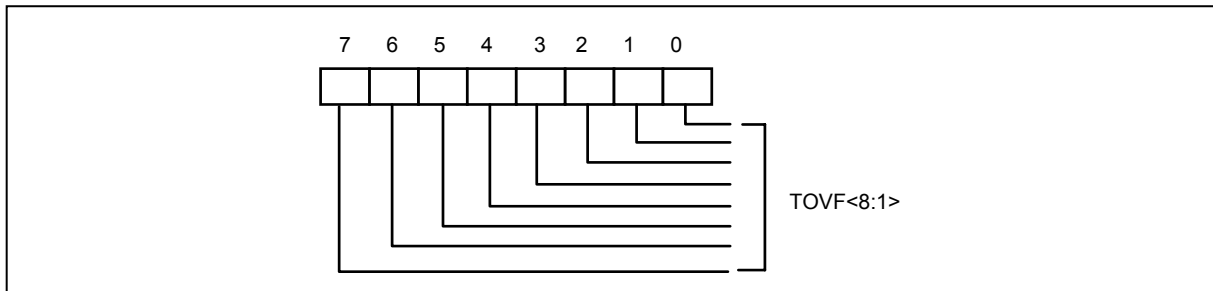

Bit 7-0: Over-temperature, bits 8-1. The nine-bit value is in units of 0.5°C, and the default is 80°C.

**8.83 AUXTIN Temperature Sensor Over-temperature (Low Byte) Register - Index 56h (Bank 2)**

Register Location: 56h  
 Power on Default Value: 00h  
 Attribute: Read/Write  
 Size: 8 bits



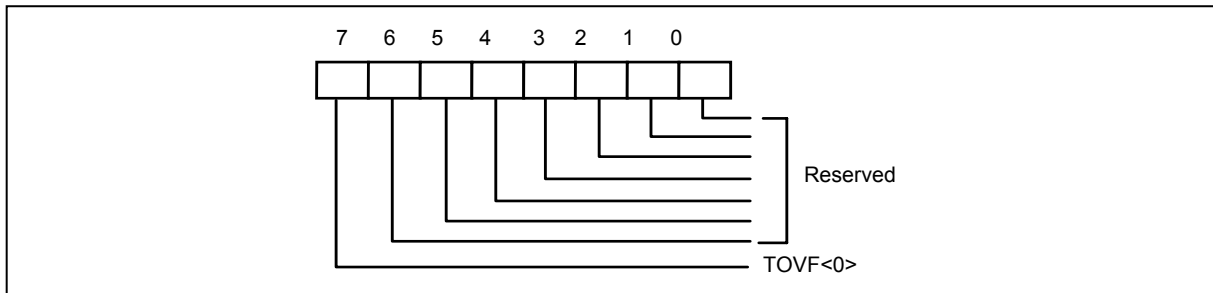

Bit 7: Over-temperature, bit 0. The nine-bit value is in units of 0.5°C.  
 Bit 6-0: Reserved.

**8.84 Interrupt Status Register 3 - Index 50h (Bank 4)**

Register Location: 50h  
 Power on Default Value: 00h  
 Attribute: Read Only  
 Size: 8 bits

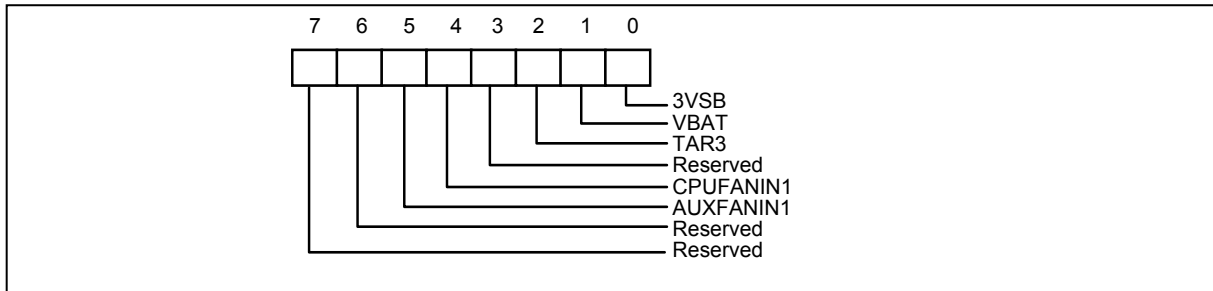

Bit 7-6: Reserved.  
 Bit 5: A one indicates the fan count limit of AUXFANIN1 has been exceeded.  
 Bit 4: A one indicates the fan count limit of CPUFANIN1 has been exceeded.  
 Bit 3: Reserved  
 Bit 2: A one indicates that the AUCTIN temperature has been over the target temperature for three minutes at full fan speed in Thermal Cruise™ mode.  
 Bit 1: A one indicates the high or low limit of VBAT has been exceeded.  
 Bit 0: A one indicates the high or low limit of 3VSB has been exceeded.



### 8.85 SMI# Mask Register 4 - Index 51h (Bank 4)

Register Location: 51h  
 Power on Default Value: 13h  
 Attribute: Read/Write  
 Size: 8 bits

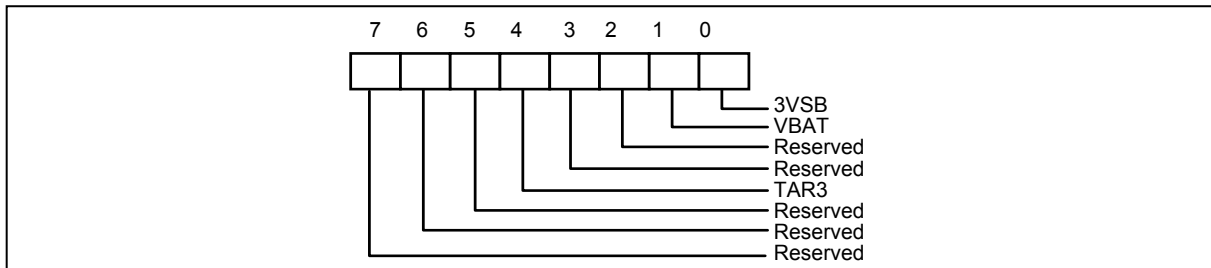

Bit 7-5: Reserved.

Bit 4: A one disables the corresponding interrupt status bit for the  $\overline{\text{SMI}}$  interrupt. (See Interrupt Status Register 3 - Index 50h (*Bank 4*))

Bit 3-2: Reserved.

Bit 1-0: A one disables the corresponding interrupt status bit for the  $\overline{\text{SMI}}$  interrupt. (See Interrupt Status Register 3 - Index 50h (*Bank 4*))

### 8.86 Reserved Register - Index 52h (Bank 4)

### 8.87 BEEP Control Register 3 - Index 53h (Bank 4)

Register Location: 53h  
 Power on Default Value: 00h  
 Attribute: Read/Write  
 Size: 8 bits

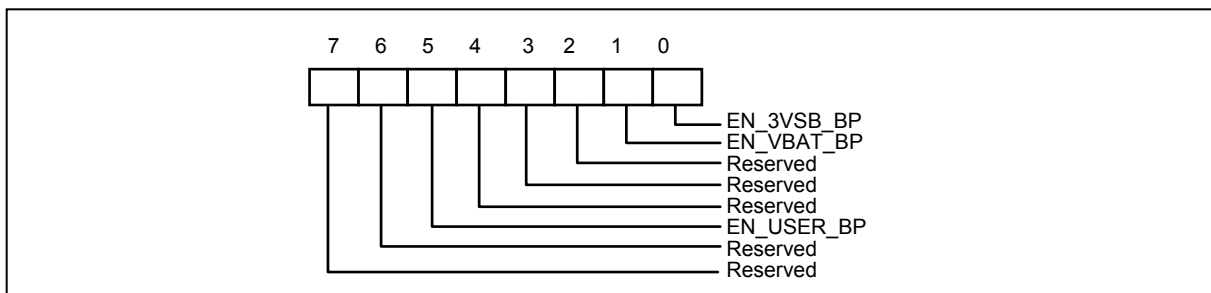

Bit 7-6: Reserved.

Bit 5: User-defined BEEP output function.

0: Make BEEP inactive. (Default)

1: Make BEEP active.

Bit 4-2: Reserved.



Bit 1: BEEP output control for VBAT if the monitored value exceeds the threshold value.

1: Enable BEEP output.

0: Disable BEEP output. (Default)

Bit 0: BEEP output control for 3VSB if the monitored value exceeds the threshold value.

1: Enable BEEP output.

0: Disable BEEP output. (Default)

### 8.88 SYSTIN Temperature Sensor Offset Register - Index 54h (Bank 4)

Register Location: 54h

Power on Default Value: 00h

Attribute: Read/Write

Size: 8 bits

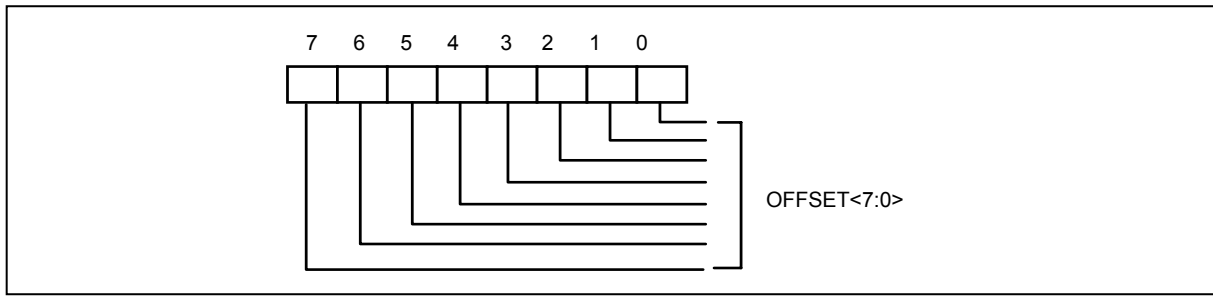

Bit 7-0: SYSTIN temperature offset value. The value in this register is added to the monitored value so that the read value will be the sum of the monitored value and this offset value.

### 8.89 CPUTIN Temperature Sensor Offset Register - Index 55h (Bank 4)

Register Location: 55h

Power on Default Value: 00h

Attribute: Read/Write

Size: 8 bits

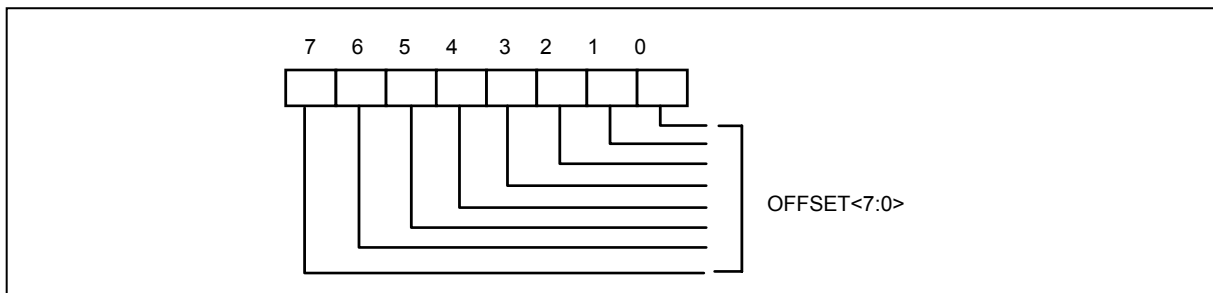

Bit 7-0: CPUTIN temperature offset value. The value in this register will be added to the monitored value so that the read value is the sum of the monitored value and this offset value.



### 8.90 AUXTIN Temperature Sensor Offset Register - Index 56h (Bank 4)

Register Location: 56h  
 Power on Default Value: 00h  
 Attribute: Read/Write  
 Size: 8 bits

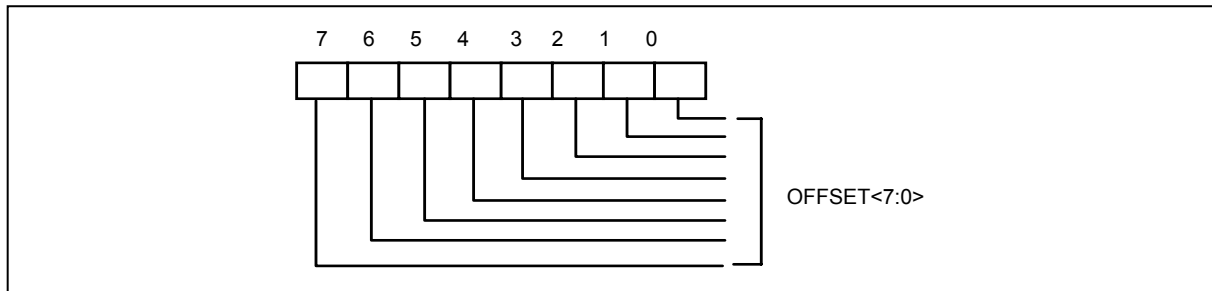

Bit 7-0: AUXTIN temperature offset value. The value in this register is added to the monitored value so that the reading value is the sum of the monitored value and this offset value.

### 8.91 Reserved Register - Index 57h-58h (Bank 4)

### 8.92 Real Time Hardware Status Register I - Index 59h (Bank 4)

Register Location: 59h  
 Power on Default Value: 00h  
 Attribute: Read Only  
 Size: 8 bits

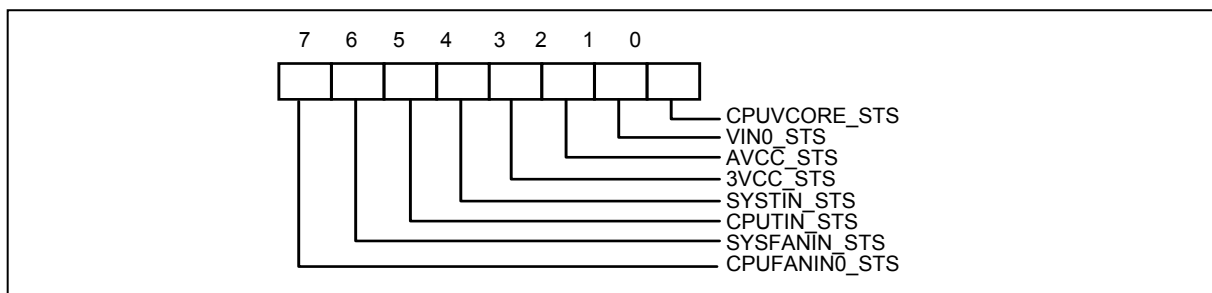

Bit 7: CPUFANIN0 status.

- 1: Fan speed count is over the threshold value.
- 0: Fan speed count is in the allowed range.

Bit 6: SYSFANIN status.

- 1: Fan speed count is over the threshold value.
- 0: Fan speed count is in the allowed range.

Bit 5: CPUTIN temperature sensor status.

- 1: Temperature exceeds the over-temperature value.
- 0: Temperature is under the hysteresis value.



Bit 4: SYSTIN temperature sensor status.

1: Temperature exceeds the over-temperature value.

0: Temperature is under the hysteresis value.

Bit 3: 3VCC Voltage status.

1: 3VCC voltage is over or under the allowed range.

0: 3VCC voltage is in the allowed range.

Bit 2: AVCC Voltage status.

1: AVCC voltage is over or under the allowed range.

0: AVCC voltage is in the allowed range.

Bit 1: VIN0 Voltage status.

1: VIN0 voltage is over or under the allowed range.

0: VIN0 voltage is in the allowed range.

Bit 0: CPUVCORE Voltage status.

1: CPUVCORE voltage is over or under the allowed range.

0: CPUVCORE voltage is in the allowed range.

### 8.93 Real Time Hardware Status Register II - Index 5Ah (Bank 4)

Register Location: 5Ah  
 Power on Default Value: 00h  
 Attribute: Read Only  
 Size: 8 bits

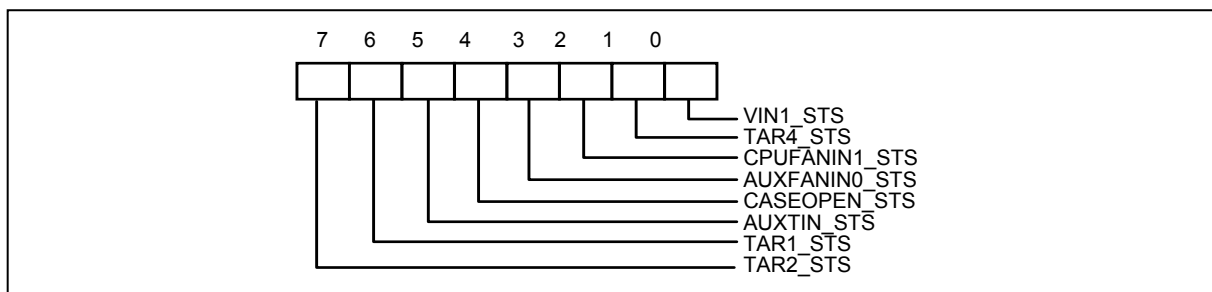

Bit 7: Smart Fan of CPUFANIN0 warning status.

1: Selected temperature has been over the target temperature for three minutes at full fan speed in Thermal Cruise™ mode.

0: Selected temperature has not reached the warning range.

Bit 6: Smart Fan of SYSFANIN warning status.

1: SYSTIN temperature has been over the target temperature for three minutes at full fan speed in Thermal Cruise™ mode.

0: SYSTIN temperature has not reached the warning range.

Bit 5: AUXTIN temperature sensor status.

1: Temperature exceeds the over-temperature value.

0: Temperature is under the hysteresis value.



- Bit 4: Case Open status.
  - 1: Case-open is detected and latched.
  - 0: Case-open is not latched.
- Bit 3: AUXFANIN0 status.
  - 1: Fan speed count is over the threshold value.
  - 0: Fan speed count is in the allowed range.
- Bit 2: CPUFANIN1 status.
  - 1: Fan speed count is over the threshold value.
  - 0: Fan speed count is in the allowed range.
- Bit 1: Smart Fan of CPUFANIN1 warning status.
  - 1: Selected temperature has been over the target temperature for three minutes at full fan speed in Thermal Cruise™ mode.
  - 0: Selected temperature has not reached the warning range.
- Bit 0: VIN1 Voltage status.
  - 1: VIN1 voltage is over or under the allowed range.
  - 0: VIN1 voltage is in the allowed range.

**8.94 Real Time Hardware Status Register III - Index 5Bh (Bank 4)**

Register Location: 5Bh  
 Power on Default Value: 00h  
 Attribute: Read Only  
 Size: 8 bits

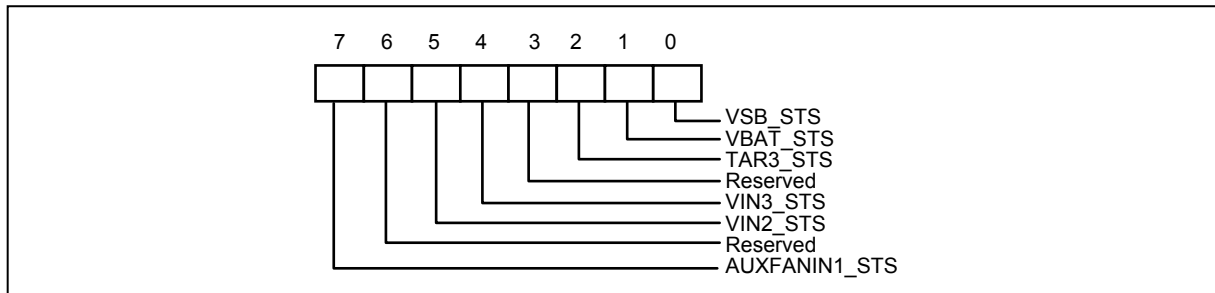

- Bit 7: AUXFANIN1 status.
  - 1: Fan speed count is over the threshold value.
  - 0: Fan speed count is in the allowed range.
- Bit 6: Reserved.
- Bit 5: VIN2 Voltage status.
  - 1: VIN2 voltage is over or under the allowed range.
  - 0: VIN2 voltage is in the allowed range.
- Bit 4: VIN3 Voltage status.
  - 1: VIN3 voltage is over or under the allowed range.
  - 0: VIN3 voltage is in the allowed range.
- Bit 3: Reserved



Bit 2: Smart Fan of AUXFANIN warning status.

1: Selected temperature has been over the target temperature for three minutes at full fan speed in Thermal Cruise™ mode.

0: Selected temperature has not reached the warning range.

Bit 1: VBAT Voltage status.

1: VBAT voltage is over or under the allowed range.

0: VBAT voltage is in the allowed range.

Bit 0: 3VSB Voltage status.

1: 3VSB voltage is over or under the allowed range.

0: 3VSB voltage is in the allowed range.

### 8.95 Reserved Register - Index 5Ch ~ 5Fh (Bank 4)

### 8.96 Value RAM 2 — Index 50h-59h (Bank 5)

ADDRESS A6-A0	DESCRIPTION
50h	3VSB reading
51h	VBAT reading. The reading is meaningless unless EN_VBAT_MN (Bank0 Index 5Dh, bit0) is set.
52h	Reserved
53h	AUXFANIN1 reading Note: This location stores the number of counts of the internal clock per revolution.
54h	3VSB High Limit
55h	3VSB Low Limit
56h	VBAT High Limit
57h	VBAT Low Limit
58h	Reserved
59h	Reserved
5Ah	Reserved
5Bh	Reserved
5Ch	AUXFANIN1 Fan Count Limit <b>Note:</b> It is the number of counts of the internal clock for the Low Limit of the fan speed.

### 8.97 Reserved Register - Index 50h ~ 57h (Bank 6)



## 9. SERIAL PERIPHERAL INTERFACE

The W83627DHG provides a bridge of the Low Pin Count (LPC) Interface to Serial Peripheral Interface (SPI). The signals in the SPI are transmitted through Pin 2 (SCK), Pin 19 (SCE#), Pin 58 (SI), and Pin 118 (SO). In the Super I/O (W83627DHG), these 4 pins are multi-functional. The SPI functions are activated through strapping. Pin 52 determines whether to enable or disable the SPI functions. In the Super I/O (W83627DHG), the SPI functions are activated when Pin 52 is pulled-up to the power source. The function status can be seen/read at CR[24h], bit 1.

The SPI is primarily used to store the BIOS ROM. When booting the computer, the memory read instructions or timing sequences are transmitted from the CPU, the South Bridge, the LPC bus to the Super I/O (W83627DHG). After receiving the instruction, the Super I/O (W83627DHG) generates and transmits the correct instructions and memory addresses to the SPI which responds with the corresponding data of the addresses. The data are placed to the LPC bus by the Super I/O (W83627DHG) and returned to the South Bridge. All of the data are read in this manner. By setting the registers shown at Table 9.3, the Super I/O (W83627DHG) supports all the instructions given, such as erase, read, program, to SPI flash. For more details, please see Table 9.2.

To make it more user-friendly, regularly used SPI instructions/functions can be generated via the LPC I/O read/write commands. That is, the flash devices with SPI can be programmed, erased, or read on the motherboard.

### 9.1 Using the SPI Interface via the LPC

- The allowed range is 8 bytes above the base address. The base address is configured at Configuration Register CR62h and CR63h in Logical Device 6. For example, if 03h is written to Configuration Register CR62h, and F8h to Configuration Register CR63h, 03F8h ~ 03FFh is the allowed range.

**Table 9.1 Base Address Setting**

LOGICAL DEVICE	CONFIGURATION REGISTER	BIT	FUNCTION
6	62	7:0	High byte of Base Address
	63	7:0	Low byte of Base Address





- Functions and Definitions

The functions and definitions of the 8 bytes are shown in the following table.

**Table 9.2 SPI Address Map**

ADDRESS	BIT	FUNCTION	DESCRIPTION
Base+0	7:0	CMD	Commands or instructions of each SPI device
Base+1	7:4	MODE	Mode execution. Please see the Table 9.3 for the details of each mode.
	3:0	ADD2	Address [19:16]
Base+2	7:0	ADD1	Address [15:8]
Base+3	7:0	ADD0	Address [7:0]
Base+4	7:0	DATA0	Data byte 0
Base+5	7:0	DATA1	Data byte 1
Base+6	7:0	DATA2	Data byte 2
Base+7	7:0	DATA3	Data byte 3

- Usages

Write SPI instructions to Base+0. Set up the addresses and the data in Base+2 ~ Base+7. Implement the instruction by setting the instruction mode in Base+1.

- Accessing SPI Devices

Take erasing the SPI for example, first write the “Chip Erase” instruction to Base+0 and 1Xh<sup>§1</sup> to Base+1 (Bit3~Bit0 of Base +1 is the parameter of address[19:16]). The instruction modes are listed in the table below. For Mode 1, only a one-byte instruction is generated. For Mode 2, in addition to a one-byte instruction, a one-byte parameter, which is set up in Base+4 in advance, is also generated.

<sup>§1</sup> The “X” of 1X stands for the parameters of the address[19:16] (A19~A16, the most significant byte (MSB) of the address).



Table 9.3 MODE

MODE	DEFINITION	FUNCTION	COMMAND EXAMPLE
1	CMD	Command only	Chip Enable, Write Enable, Write Disable
2	CMD_Da(1)	Command with 1byte data write	Write Status Register
3	CMD_Da(2)	Command with 2bytes data read	Read ID (Atmel <sup>®</sup> )
4	CMD_Add(3)	Command with 3 bytes address	Block Erase, Sector Erase
5	CMD_Ad(3)_Da(1)_W	Command with 3bytes address and 1byte data read	Byte Program (1 byte)
6	CMD_Ad(3)_Da(4)_W	Command with 3bytes address and 4bytes data write	Page Program (4 bytes)
7	CMD_Ad(4)_Da(4)_R	Command with 3bytes and a dummy byte address and 4byte data read	FAST READ (4 bytes)
8	CMD_Ad(3)_Da(1)_R	Command with 3bytes address and 1byte data read	READ, Read Status Read ID (ST/SST <sup>®</sup> )
9	CMD_Ad(3)_Da(2)_R	Command with 3bytes address and 2bytes data read	Read ID (Winbond <sup>®</sup> )
a	CMD_Ad(3)_Da(3)_R	Command with 3bytes address and 3bytes data read	Read ID (PMC <sup>®</sup> )
b	CMD_Ad(3)_Da(4)_R	Command with 3bytes address and 4 bytes data read	

■ Reading Data From SPI Devices

First, write the “Read” instruction to Base+0. Then write the addresses to Base+2 ~ Base+3. Last, write 8X to Base+1.

■ Programming SPI Devices

First, write the “Byte Program” instruction to Base+0. Then write the addresses into Base+2 ~ Base+3 and parameters to Base+4. Last, write 5X to Base+1. For correct programming, make sure the state of the device is ready and write enabled.

\* For more details, please see the Programming Guide of the W83627DHG.



## 10. FLOPPY DISK CONTROLLER

### 10.1 FDC Functional Description

The floppy disk controller (FDC) of the W83627DHG integrates all of the logic required for floppy disk control. The FDC implements a FIFO which provides better system performance in multi-master systems, and the digital data separator supports data rates up to 2 M bits/sec.

The FDC includes the following blocks: Precompensation, Data Rate Selection, Digital Data Separator, FIFO, and FDC Core. The rest of this section discusses these blocks through the following topics: FIFO, Data Separator, Write Precompensation, Perpendicular Recording mode, FDC core, FDC commands, and FDC registers.

#### 10.1.1 FIFO (Data)

The FIFO is 16 bytes in size and has programmable threshold values. All command parameter information and disk data transfers go through the FIFO. Data transfers are governed by the RQM (Request for Master) and DIO (Data Input/Output) bits in the Main Status Register.

The FIFO is defaulted to disabled mode after any form of reset, which maintains PC/AT hardware compatibility. The default values can be changed through the configure command. The advantage of the FIFO is that it lets the system have a larger DMA latency without causing disk errors. The following tables give several examples of the delays with the FIFO. The data are based upon the following formula:

$$\text{DELAY} = \text{THRESHOLD} \# \times (1 / \text{DATA RATE}) * 8 - 1.5 \mu\text{s}$$

FIFO THRESHOLD	MAXIMUM DELAY UNTIL SERVICING AT 500K BPS
	Data Rate
1 Byte	$1 \times 16 \mu\text{s} - 1.5 \mu\text{s} = 14.5 \mu\text{s}$
2 Byte	$2 \times 16 \mu\text{s} - 1.5 \mu\text{s} = 30.5 \mu\text{s}$
8 Byte	$8 \times 16 \mu\text{s} - 1.5 \mu\text{s} = 6.5 \mu\text{s}$
15 Byte	$15 \times 16 \mu\text{s} - 1.5 \mu\text{s} = 238.5 \mu\text{s}$
FIFO THRESHOLD	MAXIMUM DELAY UNTIL SERVICING AT 1M BPS
	Data Rate
1 Byte	$1 \times 8 \mu\text{s} - 1.5 \mu\text{s} = 6.5 \mu\text{s}$
2 Byte	$2 \times 8 \mu\text{s} - 1.5 \mu\text{s} = 14.5 \mu\text{s}$
8 Byte	$8 \times 8 \mu\text{s} - 1.5 \mu\text{s} = 62.5 \mu\text{s}$
15 Byte	$15 \times 8 \mu\text{s} - 1.5 \mu\text{s} = 118.5 \mu\text{s}$

At the start of a command, the FIFO is always disabled, and command parameters must be sent based upon the RQM and DIO bit settings in the Main Status Register. When the FDC enters the command execution phase, it clears the FIFO off any data to ensure that invalid data are not transferred.

An overrun or underrun terminates the current command and data transfer. Disk writes complete the current sector by generating a 00 pattern and valid CRC. Reads require the host to remove the remaining data so that the result phase may be entered.

DMA transfers are enabled by the specify command and are initiated by the FDC when the LDRQ pin is activated during a data transfer command.



### 10.1.2 Data Separator

The function of the data separator is to lock onto incoming serial read data. When a lock is achieved, the serial front-end logic in the chip is provided with a clock that is synchronized with the read data. The synchronized clock, called the Data Window, is used to internally sample the serial data portion of the bit cell, and the alternate state samples the clock portion. Serial-to-parallel conversion logic separates the read data into clock and data bytes.

The Digital Data Separator (DDS) has three parts: control logic, error adjustment, and speed tracking. The control logic generates RDD and RWD for every pulse input, and any data pulse input is synchronized and then adjusted immediately by error adjustment. A digital integrator keeps track of the speed changes in the input data stream.

### 10.1.3 Write Precompensation

The write precompensation logic minimizes bit shifts in the RDDATA stream from the disk drive. Shifting of bits is a known phenomenon in magnetic media and depends on the disk media and the floppy drive.

The FDC monitors the bit stream that is being sent to the drive. The data patterns that require precompensation are well known, so, depending on the pattern, the bit is shifted either early or late, relative to the surrounding bits.

### 10.1.4 Perpendicular Recording Mode

The FDC is also capable of interfacing directly to perpendicular recording floppy drives. Perpendicular recording differs from the traditional longitudinal method in that the magnetic bits are oriented vertically. This scheme packs more data bits into the same area.

FDCs with perpendicular recording drives can read standard 3.5" floppy disks and can read and write perpendicular media. Some manufacturers offer drives that can read and write standard and perpendicular media in a perpendicular media drive.

A single command puts the FDC into perpendicular mode. All other commands operate as they normally do. Perpendicular mode requires a 1 Mbps data rate for the FDC, and, at this data rate, the FIFO manages the host interface bottleneck due to the high speed of data transfer to and from the disk.

### 10.1.5 FDC Core

The W83627DHG FDC is capable of performing twenty commands. Each command is initiated by a multi-byte transfer from the microprocessor, and the result may be a multi-byte transfer back to the microprocessor. Each command consists of three phases: command, execution, and result.

#### Command

The microprocessor issues all required information to the controller to perform a specific operation.

#### Execution

The controller performs the specified operation.

#### Result

After the operation is completed, status information and other housekeeping information are provided to the microprocessor.

The next section introduces each of the commands.

**10.1.6 FDC Commands**

## Command Symbol Descriptions:

C:	Cylinder Number 0 - 256
D:	Data Pattern
DIR:	Step Direction DIR = 0: step out DIR = 1: step in
DS0:	Disk Drive Select 0
DS1:	Disk Drive Select 1
DTL:	Data Length
EC:	Enable Count
EFIFO:	Enable FIFO
EIS:	Enable Implied Seek
EOT:	End of Track
FIFOTHR:	FIFO Threshold
GAP:	Gap Length Selection
GPL:	Gap Length
H:	Head Number
HDS:	Head Number Select
HLT:	Head Load Time
HUT:	Head Unload Time
LOCK:	Lock EFIFO, FIFOTHR, and PTRTRK bits to prevent being affected by software reset
MFM:	MFM or FM Mode
MT:	Multitrack
N:	The number of data bytes written in a sector
NCN:	New Cylinder Number
ND:	Non-DMA Mode
OW:	Overwritten
PCN:	Present Cylinder Number
POLL:	Polling Disable
PRETRK:	Precompensation Start Track Number
R:	Record
RCN:	Relative Cylinder Number
R/W:	Read/Write
SC:	Sectors per Cylinder
SK:	Skip deleted data address mark
SRT:	Step Rate Time
ST0:	Status Register 0
ST1:	Status Register 1
ST2:	Status Register 2
ST3:	Status Register 3
WG:	Write gate alters timing of WE



(1) Read Data

PHASE	R/W	D7	D6	D5 D1	D4 D0	D3	D2	REMARKS	
Command	W	MT 1	MFM 1	SK 0		0	0	Command codes  Sector ID information prior to command execution	
	W	0	0	0		0	0		
		HDS	DS1 DS0						
	W				C				
	W				H				
	W				R				
	W				N				
	W				EOT				
	W				GPL				
	W				DTL				
Execution								Data transfer between the FDD and system	
Result	R				ST0			Status information after command execution	
	R				ST1				
	R				ST2				
	R				C			Sector ID information after command execution	
	R				H				
	R				R				
	R				N				



(2) Read Deleted Data

PHASE	R/W	D7	D6	D5 D1	D4 D0	D3	D2	REMARKS
Command	W	MT 0	MFM 0	SK	0	1	1	Command codes  Sector ID information prior to command execution
	W	0 HDS	0 DS1	0 DS0	0	0	0	
	W	----- C -----						
	W	----- H -----						
	W	----- R -----						
	W	----- N -----						
	W	----- EOT -----						
	W	----- GPL -----						
W	----- DTL -----							
Execution								Data transfer between the FDD and system
Result	R	----- ST0 -----						Status information after command execution
	R	----- ST1 -----						
	R	----- ST2 -----						
	R	----- C -----						Sector ID information after command execution
	R	----- H -----						
	R	----- R -----						
	R	----- N -----						



(3) Read A Track

PHASE	R/W	D7	D6	D5 D1	D4 D0	D3	D2	REMARKS
Command	W	0	MFM	0	0	0		Command codes  Sector ID information prior to command execution
		0	1	0				
	W	0	0	0	0	0		
		HDS	DS1	DS0				
	W				C			
	W				H			
	W				R			
	W				N			
	W				EOT			
W				GPL				
W				DTL				
Execution								Data transfer between the FDD and system; FDD reads contents of all cylinders from index hole to EOT
Result	R				ST0			Status information after command execution  Sector ID information after command execution
	R				ST1			
	R				ST2			
	R				C			
	R				H			
	R				R			
	R				N			





## (4) Read ID

PHASE	R/W	D7	D6	D5 D1	D4 D0	D3	D2	REMARKS
Command	W	0	MFM	0	0	1		Command codes
	W	0	1	0				
		0	0	0	0	0	0	
		HDS	DS1	DS0				
Execution								The first correct ID information on the cylinder is stored in the Data Register
Result	R				ST0			Status information after command execution
	R				ST1			
	R				ST2			
	R				C			Disk status after the command has been completed
	R				H			
	R				R			
	R				N			

## (5) Verify

PHASE	R/W	D7	D6	D5 D1	D4 D0	D3	D2	REMARKS	
Command	W	MT	MFM	SK	1	0	1	Command codes	
	W	1	0						
	W	EC	0	0	0	0			
	W	HDS	DS1	DS0					
	W				C				Sector ID information prior to command execution
	W				H				
	W				R				
	W				N				
W				EOT					
W				GPL					
W				DTL/SC					
Execution								No data transfer takes place	
Result	R				ST0			Status information after command execution	
	R				ST1				
	R				ST2				
	R				C			Sector ID information after command execution	
	R				H				
	R				R				
	R				N				



(6) Version

PHASE	R/W	D7	D6	D5 D1	D4 D0	D3	D2	REMARKS
Command	W	0 0	0 0	0 0	0 0	1	0	Command code
Result	R	1 0	0 0	0 0	0 0	1	0	Enhanced controller

(7) Write Data

PHASE	R/W	D7	D6	D5 D1	D4 D0	D3	D2	REMARKS
Command	W	MT 1	MFM 0	0 1	0	0	0	Command codes  Sector ID information prior to Command execution
	W	0 HDS	0 DS1	0 DS0	0	0	0	
	W				----- C -----			
	W				----- H -----			
	W				----- R -----			
	W				----- N -----			
	W				----- EOT -----			
	W				----- GPL -----			
	W				----- DTL -----			
Execution								Data transfer between the FDD and the system
Result	R				----- ST0 -----			Status information after Command execution  Sector ID information after Command execution
	R				----- ST1 -----			
	R				----- ST2 -----			
	R				----- C -----			
	R				----- H -----			
	R				----- R -----			
	R				----- N -----			



(8) Write Deleted Data

PHASE	R/W	D7	D6	D5 D1	D4 D0	D3	D2	REMARKS	
Command	W	MT 0	MFM 0	0 1	0	1		Command codes	
	W	0 HDS	0 DS1		0 DS0	0	0	Sector ID information prior to command execution	
	W						----- C -----		
	W						----- H -----		
	W						----- R -----		
	W						----- N -----		
	W						----- EOT -----		
	W						----- GPL -----		
	W						----- DTL -----		
Execution								Data transfer between the FDD and the system	
Result	R							----- ST0 -----	Status information after command execution
	R							----- ST1 -----	
	R							----- ST2 -----	
	R							----- C -----	Sector ID information after command execution
	R							----- H -----	
	R							----- R -----	
	R							----- N -----	



**(9) Format A Track**

PHASE	R/W	D7	D6	D5 D1	D4 D0	D3	D2	REMARKS	
Command	W	0	MFM	0	0	1		Command codes	
		1	0	1					
	W	0	0	0	0	0			
		HDS	DS1	DS0					
	W				N				Bytes per Sector
	W				SC				Sectors per Cylinder
W				GPL			Gap 3		
W				D			Filler Byte		
Execution for Each Sector: (Repeat)	W				C			Input Sector Parameters	
	W				H				
	W				R				
	W				N				
Result	R				ST0			Status information after command execution	
	R				ST1				
	R				ST2				
	R				Undefined				
	R				Undefined				
	R				Undefined				
R				Undefined					

**(10) Recalibrate**

PHASE	R/W	D7	D6	D5 D1	D4 D0	D3	D2	REMARKS
Command	W	0	0	0	0	0		Command codes
		1	1	1				
	W	0	0	0	0	0		
		0	DS1	DS0				
Execution								Head retracted to Track 0 Interrupt



## (11) Sense Interrupt Status

PHASE	R/W	D7	D6	D5 D1	D4 D0	D3	D2	REMARKS
Command	W	0	0	0	0		1	Command code
		0	0	0				
Result	R	----- ST0 -----						Status information at the end of each seek operation
	R	----- PCN -----						

## (12) Specify

PHASE	R/W	D7	D6	D5 D1	D4 D0	D3	D2	REMARKS
Command	W	0	0	0	0		0	Command codes
		0	1	1				
	W	-----SRT-----			-----HUT-----			
	W	-----HLT-----						ND

## (13) Seek

PHASE	R/W	D7	D6	D5 D1	D4 D0	D3	D2	REMARKS
Command	W	0	0	0	0		1	Command codes
		1	1	1				
	W	0	0	0	0		0	
	W	HDS	DS1	DS0				
		----- NCN -----						
Execution	R							Head positioned over proper cylinder on the diskette

## (14) Configure

PHASE	R/W	D7	D6	D5 D1	D4 D0	D3	D2	REMARKS
Command	W	0	0	0	1		0	Configure information
		0	1	1				
	W	0	0	0	0		0	
	W	0	0	0				
	W	0	EIS	EFIFO	POLL	-----FIFOTHR		
					---			
		-----PRETRK-----						
Execution								Internal registers written



## (15) Relative Seek

PHASE	R/W	D7	D6	D5 D1	D4 D0	D3	D2	REMARKS
Command	W	1	DIR	0	0	1		Command codes
		1	1	1				
	W	0	0	0	0	0		
	W	HDS	DS1 DS0					
		----- RCN -----						

## (16) Dumpreg

PHASE	R/W	D7	D6	D5 D1	D4 D0	D3	D2	REMARKS
Command	W	0	0	0	0	1		Registers placed in FIFO
		1	1	0				
Result	R	----- PCN-Drive 0-----						
	R	----- PCN-Drive 1 -----						
	R	----- PCN-Drive 2-----						
	R	----- PCN-Drive 3 -----						
	R	-----SRT -----				----- HUT -----		
	R	----- HLT -----					ND	
	R	----- SC/EOT -----						
	R	LOCK	0	D3	D2	D1	D0	GAP
	R		WG					
	R	0	EIS	EFIFO	POLL		FIFOTHR	-----
		-----PRETRK-----						

## (17) Perpendicular Mode

PHASE	R/W	D7	D6	D5 D1	D4 D0	D3	D2	REMARKS
Command	W	0	0	0	0	1	0	Command Code
		0	1	0				
	W	OW	0	D3	D2	D1	D0	
		GAP	WG					

## (18) Lock

PHASE	R/W	D7	D6	D5 D1	D4 D0	D3	D2	REMARKS
Command	W	LOCK	0	0	1	0		Command Code
		1	0	0				
Result	R	0	0	0	LOCK	0		
		0	0	0				



**(19) Sense Drive Status**

PHASE	R/W	D7	D6	D5 D1	D4 D0	D3	D2	REMARKS
Command	W	0	0	0	0	0	0	Command Code
	W	1	0	0				
		0	0	0	0	0	0	
		HDS	DS1	DS0				
Result	R	----- ST3 -----						Status information about the disk drive

**(20) Invalid**

PHASE	R/W	D7	D6	D5 D1	D4 D0	D3	D2	REMARKS
Command	W	----- Invalid Codes -----						Invalid codes (no operation-FDC goes to standby state)
Result	R	----- ST0 -----						ST0 = 80h



**10.2 Register Descriptions**

There are several status, data, and control registers in the W83627DHG. These registers are defined below, and the rest of this section provides more details about each one of them.

ADDRESS OFFSET	REGISTER	
	READ	WRITE
base address + 0	SA REGISTER	
base address + 1	SB REGISTER	
base address + 2		DO REGISTER
base address + 3	TD REGISTER	TD REGISTER
base address + 4	MS REGISTER	DR REGISTER
base address + 5	DT (FIFO) REGISTER	DT (FIFO) REGISTER
base address + 7	DI REGISTER	CC REGISTER

**10.2.1 Status Register A (SA Register) (Read base address + 0)**

Along with the SB register, the SA register is used to monitor several disk-interface pins in PS/2 and Model 30 modes. In PS/2 mode, the bit definitions for this register are as follows:

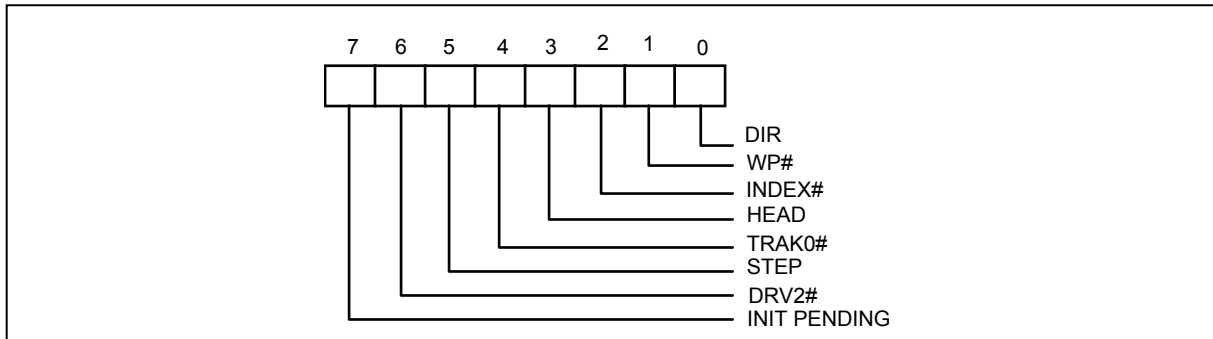

**INIT PENDING (Bit 7):**  
This bit indicates the value of the floppy disk interrupt output.

**RESERVED (Bit 6)**

**STEP (Bit 5):**  
This bit indicates the complement of the STEP# output.

**TRAK0#(Bit 4):**  
This bit indicates the value of the TRAK0# input.

**HEAD (Bit 3):**  
This bit indicates the complement of the HEAD# output.

0 side 0  
1 side 1





## INDEX#(Bit 2):

This bit indicates the value of the INDEX# output.

## WP#(Bit 1):

- 0 disk is write-protected
- 1 disk is not write-protected

## DIR (Bit 0)

This bit indicates the direction of head movement.

- 0 outward direction
- 1 inward direction

In PS/2 Model 30 mode, the bit definitions for this register are as follows:

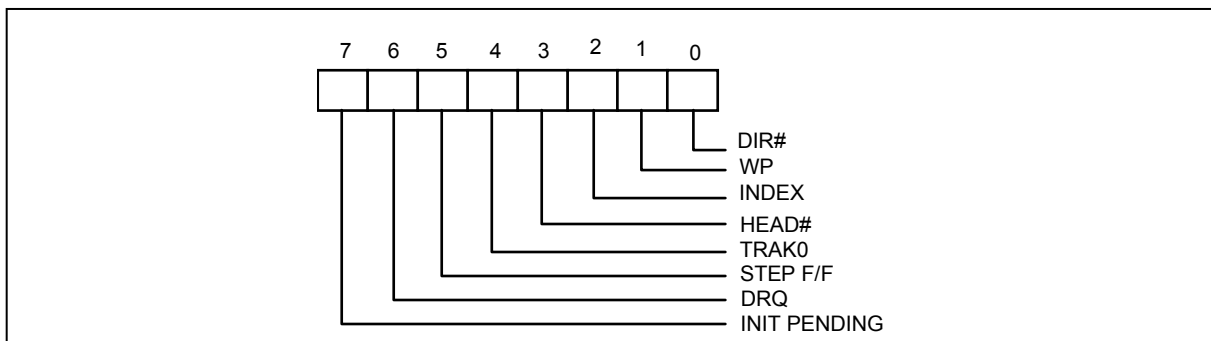

## INIT PENDING (Bit 7):

This bit indicates the value of the floppy disk interrupt output.

## DRQ (Bit 6):

This bit indicates the value of the DRQ output pin.

## STEP F/F (Bit 5):

This bit indicates the complement of the latched STEP# output.

## TRAK0 (Bit 4):

This bit indicates the complement of the TRAK0# input.

## HEAD# (Bit 3):

This bit indicates the value of the HEAD# output.

- 0 side 1
- 1 side 0

## INDEX (Bit 2):

This bit indicates the complement of the INDEX# output.



WP (Bit 1):

- 0 disk is not write-protected
- 1 disk is write-protected

DIR# (Bit 0)

This bit indicates the direction of head movement.

- 0 inward direction
- 1 outward direction

### 10.2.2 Status Register B (SB Register) (Read base address + 1)

Along with the SA register, the SB register is used to monitor several disk interface pins in PS/2 and Model 30 modes. In PS/2 mode, the bit definitions for this register are as follows:

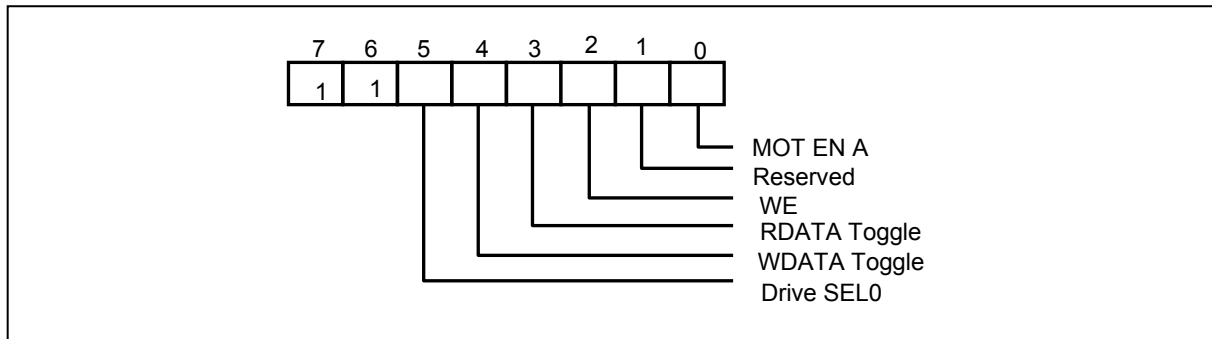

Drive SEL0 (Bit 5):

This bit indicates the status of the DO REGISTER, bit 0 (drive-select bit 0).

WDATA Toggle (Bit 4):

This bit changes state on every rising edge of the WD# output pin.

RDATA Toggle (Bit 3):

This bit changes state on every rising edge of the RDATA# output pin.

WE (Bit 2):

This bit indicates the complement of the WE# output pin.

RESERVED (Bit 1)

MOT EN A (Bit 0)

This bit indicates the complement of the MOA# output pin.

In PS/2 Model 30 mode, the bit definitions for this register are as follows:

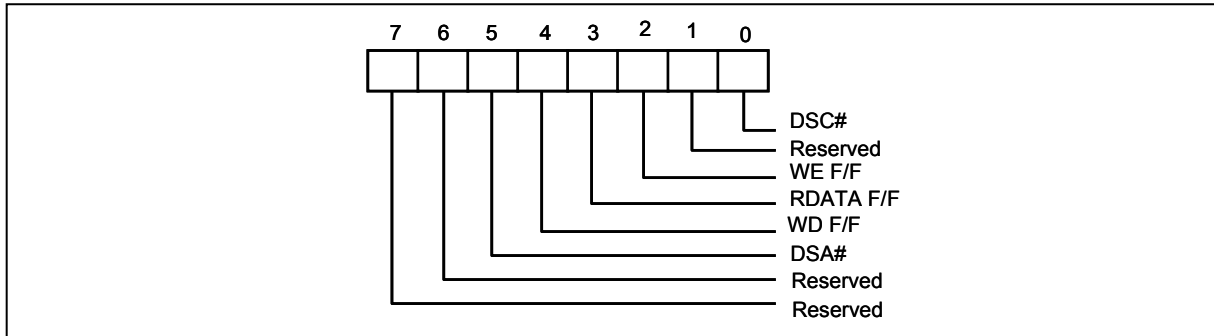

RESERVED (Bit 7)

RESERVED (Bit 6)

DSA# (Bit 5):

This bit indicates the status of the DSA# output pin.

WD F/F (Bit 4):

This bit indicates the complement of the WD# output pin, which is latched on every rising edge of the WD# output pin.

RDATA F/F (Bit 3):

This bit indicates the complement of the latched RDATA# output pin.

WE F/F (Bit 2):

This bit indicates the complement of the latched WE# output pin.

RESERVED (Bit 1)

RESERVED (Bit 0)



**10.2.3 Digital Output Register (DO Register) (Write base address + 2)**

The Digital Output Register is a write-only register that controls drive motors, drive selection, DRQ/IRQ enable, and FDC reset. The bit definitions are as follows:

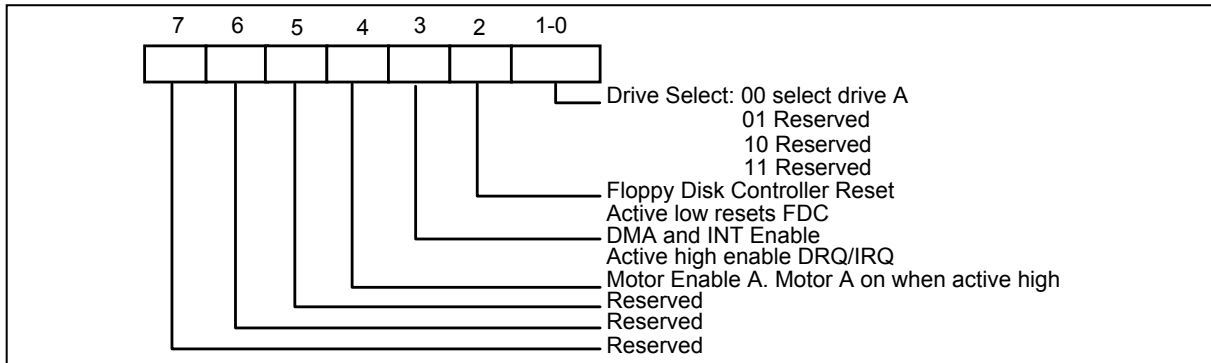

**10.2.4 Tape Drive Register (TD Register) (Read base address + 3)**

This register is used to assign a particular drive number to the tape drive support mode of the data separator. This register also holds the media ID, drive type, and floppy boot drive information for the floppy disk drive.

In normal floppy mode, this register only has bits 0 and 1, and the bit definitions are as follows:

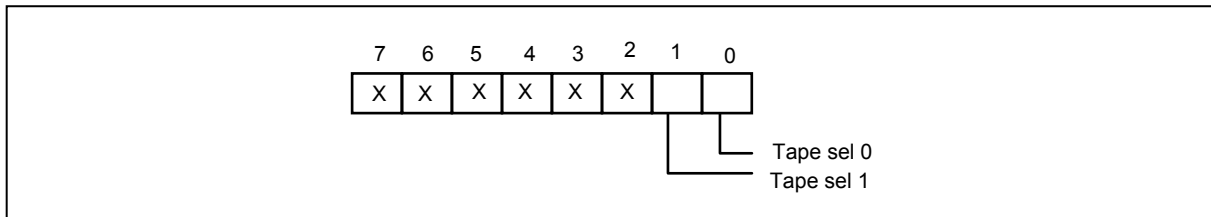

If the three-mode FDD function is enabled (EN3MODE = 1 in LD0 CRF0, Bit 0), the bit definitions are as follows:

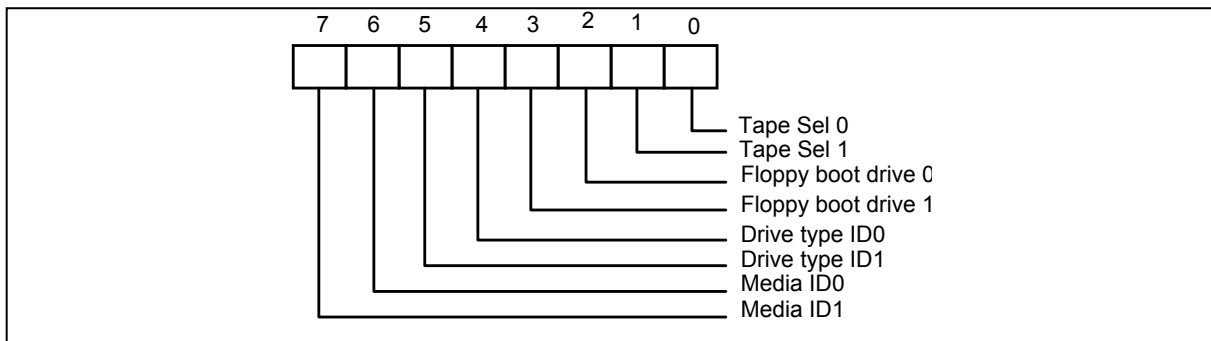

Media ID1 Media ID0 (Bit 7, 6):

These two bits are read-only. These two bits reflect the value of LD0 CRF1, bits 5 and 4.



Drive type ID1 Drive type ID0 (Bit 5, 4):

These two bits reflect two of the bits in LD0 CRF2. Which two bits are reflected depends on the last drive selection in the DO register.

Floppy Boot drive 1, 0 (Bit 3, 2):

These two bits reflect the value of LD0 CRF1, bits 7 and 6.

Tape Sel 1, Tape Sel 0 (Bit 1, 0):

These two bits assign a logical drive number to the tape drive. Drive 0 is not available as a tape drive and is reserved for the floppy disk boot drive.

TAPE SEL 1	TAPE SEL 0	DRIVE SELECTED
0	0	None
0	1	1
1	0	2
1	1	3

**10.2.5 Main Status Register (MS Register) (Read base address + 4)**

The Main Status Register is used to control the flow of data between the microprocessor and the controller. The bit definitions for this register are as follows:

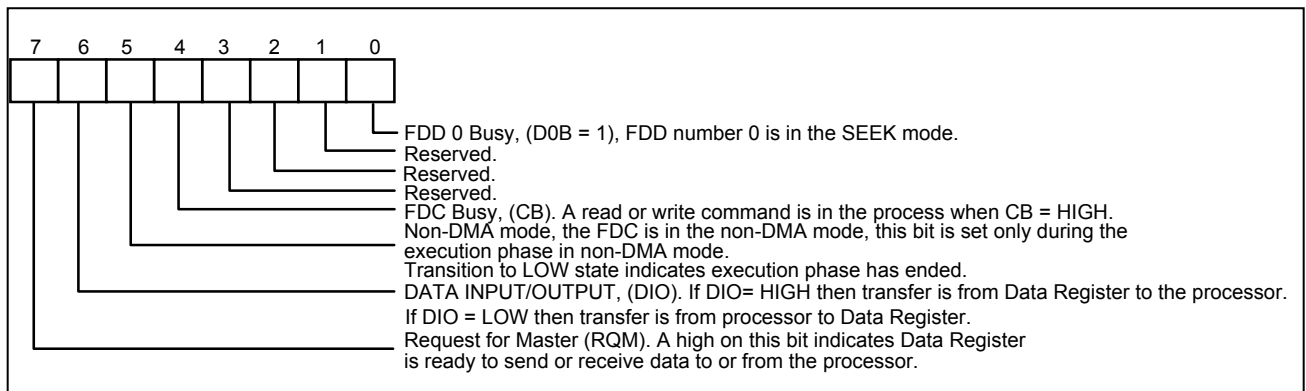

**10.2.6 Data Rate Register (DR Register) (Write base address + 4)**

The Data Rate Register is used to set the transfer rate and write precompensation. However, in PC-AT and PS/2 Model 30 and PS/2 modes, the data rate is controlled by the CC register, not by the DR register. As a result, the real data rate is determined by the most recent write to either the DR or CC register. The bit definitions for this register are as follows:

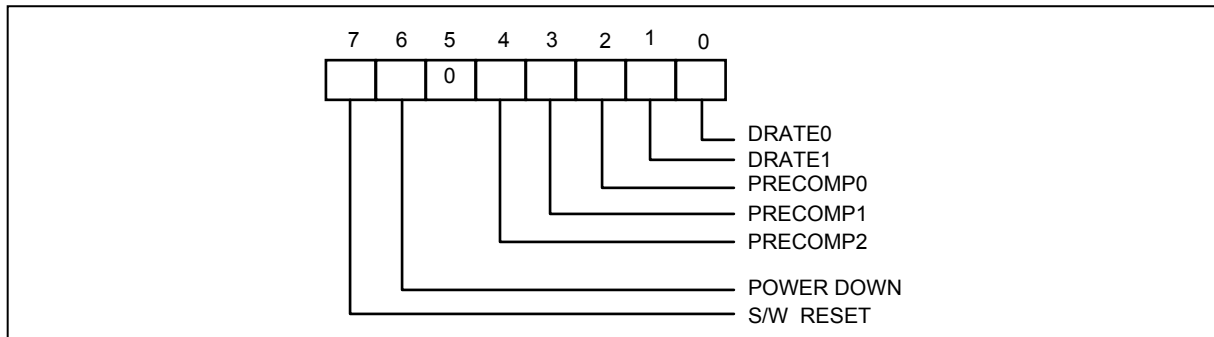

**S/W RESET (Bit 7):**

This bit is the software reset bit.

**POWER-DOWN (Bit 6):**

- 0 FDC in normal mode
- 1 FDC in power-down mode

**PRECOMP2 PRECOMP1 PRECOMP0 (Bit 4, 3, 2):**

These three bits select the value of write precompensation. The following tables show the precompensation values for every combination of these bits.

PRECOMP			PRECOMPENSATION DELAY	
2	1	0	250K - 1 Mbps	2 Mbps Tape drive
0	0	0	Default Delays	Default Delays
0	0	1	41.67 ns	20.8 ns
0	1	0	83.34 ns	41.17 ns
0	1	1	125.00 ns	62.5ns
1	0	0	166.67 ns	83.3 ns
1	0	1	208.33 ns	104.2 ns
1	1	0	250.00 ns	125.00 ns
1	1	1	0.00 ns (disabled)	0.00 ns (disabled)

DATA RATE	DEFAULT PRECOMPENSATION DELAYS
250 KB/S	125 ns
300 KB/S	125 ns
500 KB/S	125 ns
1 MB/S	41.67ns
2 MB/S	20.8 ns



DRATE1 DRATE0 (Bit 1, 0):

These two bits select the data rate of the FDC and reduced write-current control.

- 00 500 KB/S (MFM), 250 KB/S (FM), RWC# = 1
- 01 300 KB/S (MFM), 150 KB/S (FM), RWC# = 0
- 10 250 KB/S (MFM), 125 KB/S (FM), RWC# = 0
- 11 1 MB/S (MFM), Illegal (FM), RWC# = 1

The 2 MB/S data rate for the tape drive is only supported by setting DRATE1 and DRATE0 to 01, as well as setting DRT1 and DRT0 (CRF4 and CRF5 for logical device 0) to 10. Please see the functional description of CRF4 or CRF5 and the data rate table for individual data-rate settings.

**10.2.7 FIFO Register (R/W base address + 5)**

The FIFO register consists of four status registers in a stack, and only one register is presented to the data bus at a time. The FIFO register stores data, commands, and parameters, and it provides disk-drive status information. In addition, data bytes pass through the data register to program or obtain results after a command. In the W83627DHG, this register is disabled after reset. The FIFO can enable it and change its values through the configure command.

**Status Register 0 (ST0)**

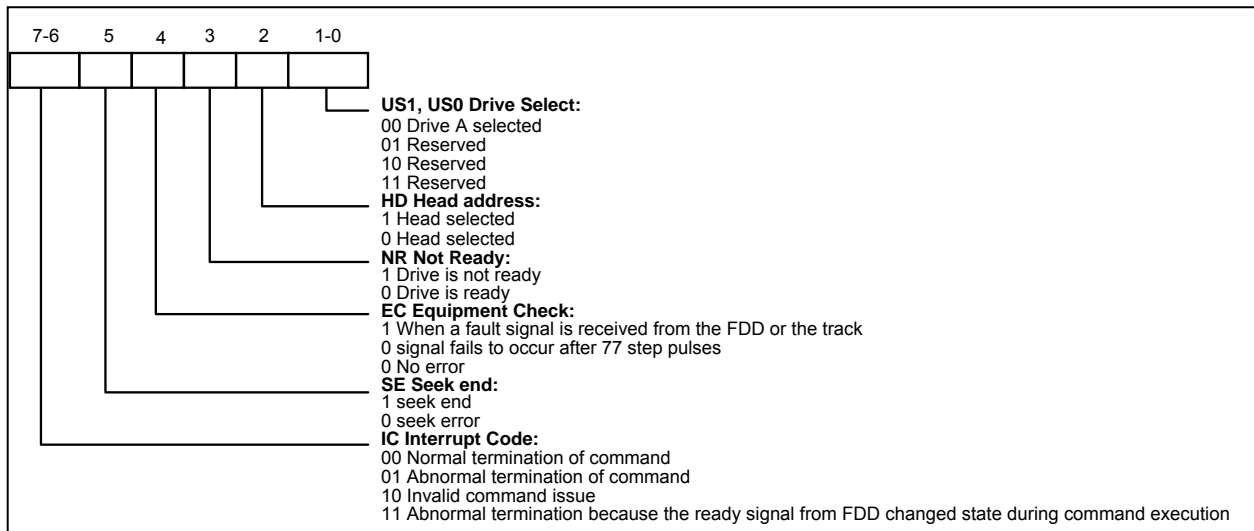



**Status Register 1 (ST1)**

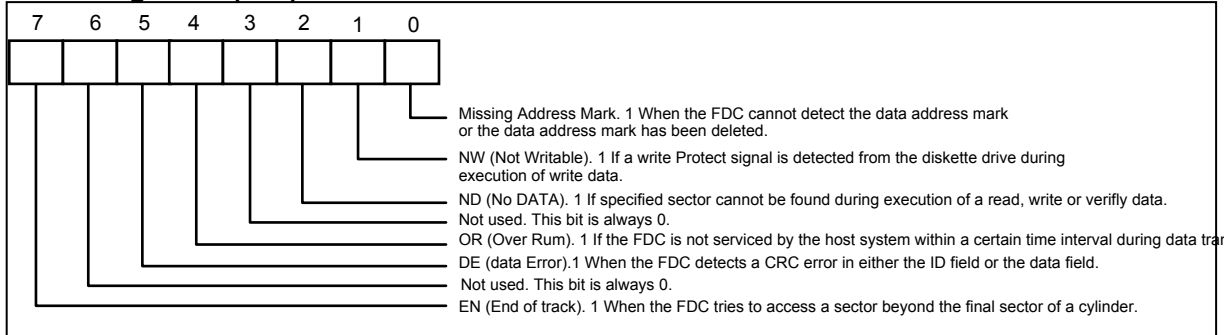

**Status Register 2 (ST2)**

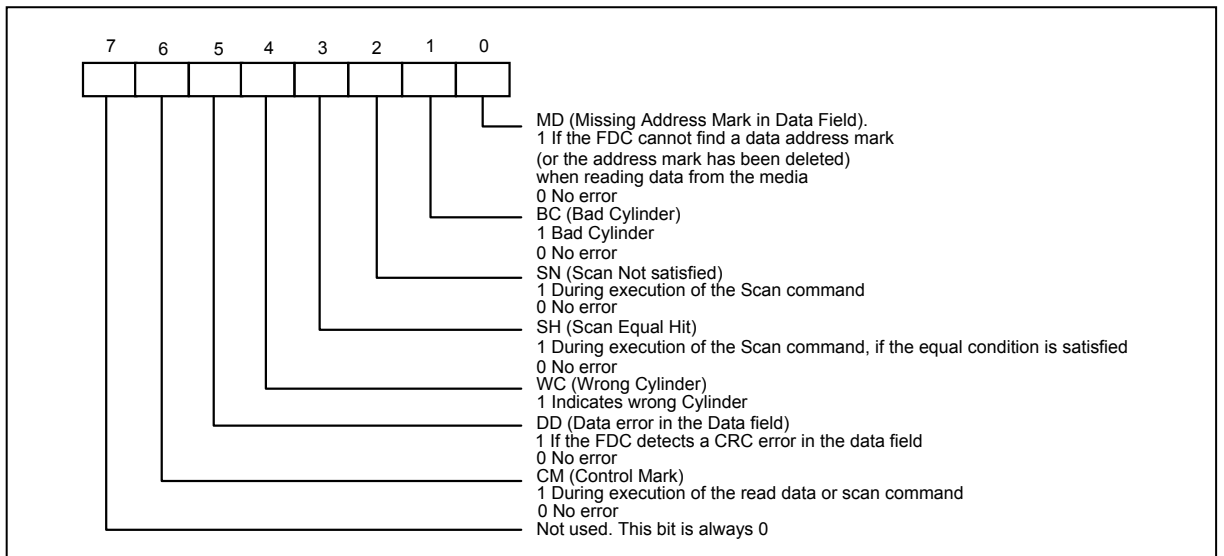

**Status Register 3 (ST3)**

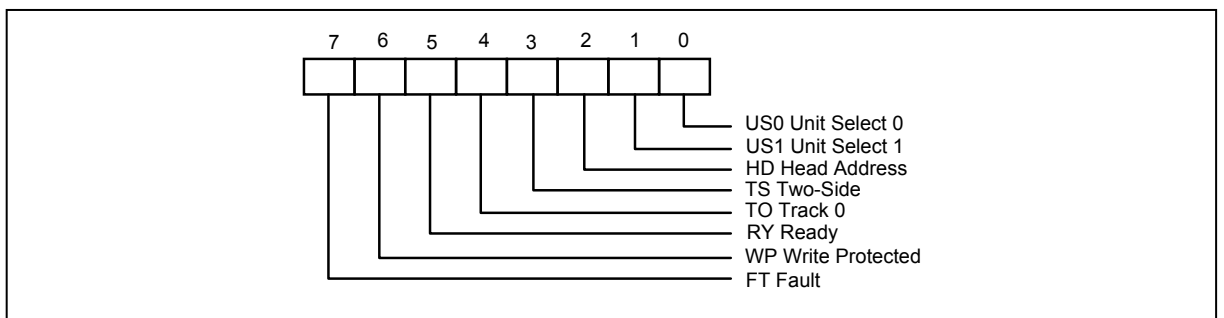





### 10.2.8 Digital Input Register (DI Register) (Read base address + 7)

The Digital Input Register is an 8-bit, read-only register used for diagnostic purposes. In PC/XT or PC/AT mode, only bit 7 is checked by the BIOS. When the register is read, bit 7 shows the complement of DSKCHG#, while the other bits remain in tri-state. The bit definitions are as follows:

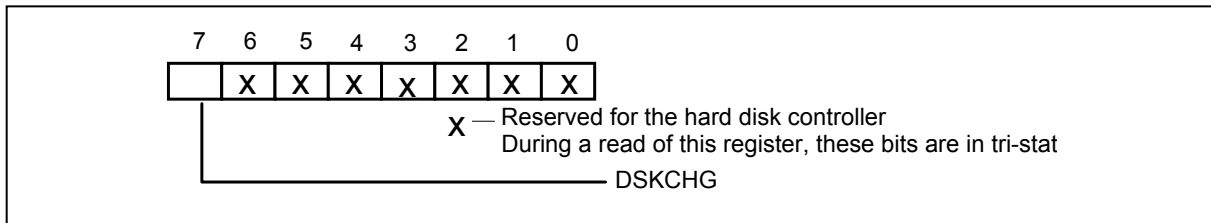

In PS/2 mode, the bit definitions are as follows:

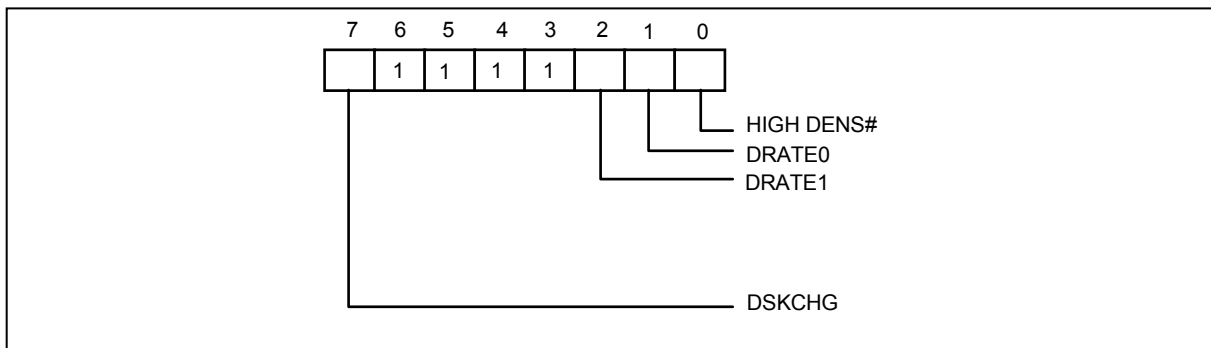

DSKCHG (Bit 7):

This bit indicates the complement of the DSKCHG# input.

Bit 6-3: These bits are always a logic 1 during a read.

DRATE1 DRATE0 (Bit 2, 1):

These two bits select the data rate of the FDC. See DR register bits 1 and 0 (Data Rate Register (DR Register) (Write base address + 4)) for how the settings correspond to individual data rates.

HIGHDENS# (Bit 0):

- 0 500 KB/S or 1 MB/S data rate (high-density FDD)
- 1 250 KB/S or 300 KB/S data rate

In PS/2 Model 30 mode, the bit definitions are as follows:

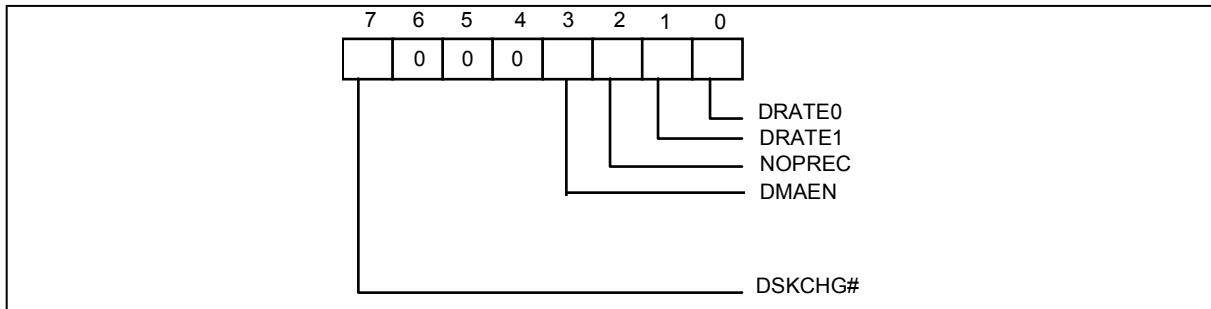

**DSKCHG (Bit 7):**

This bit indicates the status of the DSKCHG# input.

Bit 6-4: These bits are always a logic 0 during a read.

**DMAEN (Bit 3):**

This bit indicates the value of DO register, bit 3.

**NOPREC (Bit 2):**

This bit indicates the value of the NOPREC bit in the CC REGISTER.

**DRATE1 DRATE0 (Bit 1, 0):**

These two bits select the data rate of the FDC. See DR register bits 1 and 0 (Data Rate Register (DR Register) (Write base address + 4)) for how the settings correspond to individual data rates.

**10.2.9 Configuration Control Register (CC Register) (Write base address + 7)**

This register is used to control the data rate. In PC/AT and PS/2 mode, the bit definitions are as follows:

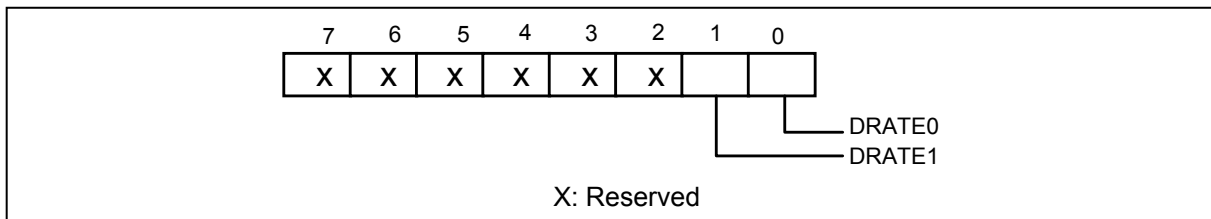

Bit 7-2: Reserved. These bits should be set to 0.

**DRATE1 DRATE0 (Bit 1, 0):**

These two bits select the data rate of the FDC. See DR register bits 1 and 0 (Data Rate Register (DR Register) (Write base address + 4)) for how the settings correspond to individual data rates.



In the PS/2 Model 30 mode, the bit definitions are as follows:

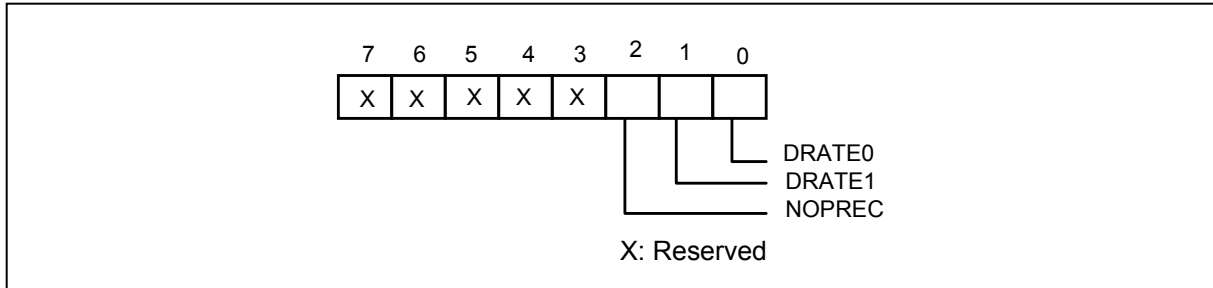

Bit 7-3: Reserved. These bits should be set to 0.

NOPREC (Bit 2):

This bit disables the precompensation function. It can be set by the software.

DRATE1 DRATE0 (Bit 1, 0):

These two bits select the data rate of the FDC. See DR register bits 1 and 0 (Data Rate Register (DR Register) (Write base address + 4)) for how the settings correspond to individual data rates.



## 11. UART PORT

### 11.1 Universal Asynchronous Receiver/Transmitter (UART A, UART B)

The UARTs are used to convert parallel data into serial format for transmission and to convert serial data into parallel format during reception. The serial data format is a start bit, followed by five to eight data bits, a parity bit (if programmed) and one, one-and-a-half (five-bit format only) or two stop bits. The UARTs are capable of handling divisors of 1 to 65535 and producing a 16x clock for driving the internal transmitter logic. Provisions are also included to use this 16x clock to drive the receiver logic. The UARTs also support the MIDI data rate. Furthermore, the UARTs also include a complete modem control capability and 16-byte FIFOs for reception and transmission to reduce the number of interrupts presented to the CPU.

### 11.2 Register Description

#### 11.2.1 UART Control Register (UCR) (Read/Write)

The UART Control Register defines and controls the protocol for asynchronous data communication, including data length, stop bit, parity, and baud rate selection.

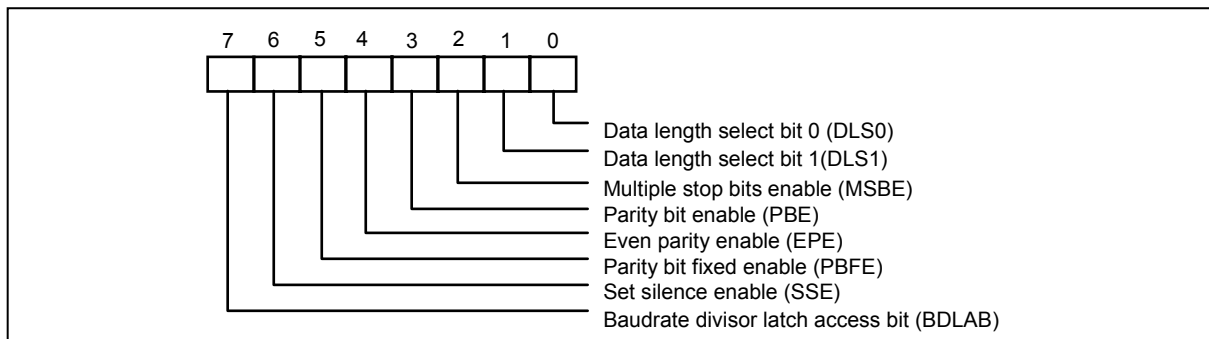

Bit 7: BDLAB. When this bit is set to logical 1, designers can access the divisor (in 16-bit binary format) from the divisor latches of the baud-rate generator during a read or write operation. When this bit is set to logical 0, the Receiver Buffer Register, the Transmitter Buffer Register, and the Interrupt Control Register can be accessed.

Bit 6: SSE. A logical 1 forces the Serial Output (SOUT) to a silent state (a logical 0). Only IRTX is affected by this bit; the transmitter is not affected.

Bit 5: PBFE. When PBE and PBFE of UCR are both set to logical 1,  
 (1) if EPE is logical 1, the parity bit is fixed as logical 0 when transmitting and checking.  
 (2) if EPE is logical 0, the parity bit is fixed as logical 1 when transmitting and checking.

Bit 4: EPE. When PBE is set to logical 1, this bit counts the number of logical 1's in the data word bits and determines the parity bit. When this bit is set to logical 1, the parity bit is set to logical 1 if an even number of logical 1's are sent or checked. When the bit is set to logical 0, the parity bit is logical 1 if an odd number of logic 1's are sent or checked.

Bit 3: PBE. When this bit is set to logical 1, the transmitter inserts a stop bit between the last data bit and the stop bit of the SOUT, and the receiver checks the parity bit in the same position.



Bit 2: MSBE. This bit defines the number of stop bits in each serial character that is transmitted or received.

- (1) If MSBE is set to logical 0, one stop bit is sent and checked.
- (2) If MSBE is set to logical 1 and the data length is 5 bits, one-and-a-half stop bits are sent and checked.
- (3) If MSBE is set to logical 1 and the data length is 6, 7, or 8 bits, two stop bits are sent and checked.

Bits 0 and 1: DLS0, DLS1. These two bits define the number of data bits that are sent or checked in each serial character.

<b>DLS1</b>	<b>DLS0</b>	<b>DATA LENGTH</b>
0	0	5 bits
0	1	6 bits
1	0	7 bits
1	1	8 bits

The following table identifies the remaining UART registers. Each one is described separately in the following sections.



		Bit Number								
Register Address Base			0	1	2	3	4	5	6	7
+ 0 BDLAB = 0	Receiver Buffer Register (Read Only)	RBR	RX Data Bit 0	RX Data Bit 1	RX Data Bit 2	RX Data Bit 3	RX Data Bit 4	RX Data Bit 5	RX Data Bit 6	RX Data Bit 7
+ 0 BDLAB = 0	Transmitter Buffer Register (Write Only)	TBR	TX Data Bit 0	TX Data Bit 1	TX Data Bit 2	TX Data Bit 3	TX Data Bit 4	TX Data Bit 5	TX Data Bit 6	TX Data Bit 7
+ 1 BDLAB = 0	Interrupt Control Register	ICR	RBR Data Ready Interrupt Enable (ERDRI)	TBR Empty Interrupt Enable (ETBREI)	USR Interrupt Enable (EUSRI)	HSR Interrupt Enable (EHSRI)	0	0	0	0
+ 2	Interrupt Status Register (Read Only)	ISR	"0" if Interrupt Pending	Interrupt Status Bit (0)	Interrupt Status Bit (1)	Interrupt Status Bit (2)**	0	0	FIFOs Enabled **	FIFOs Enabled **
+ 2	UART FIFO Control Register (Write Only)	UFR	FIFO Enable	RCVR FIFO Reset	XMIT FIFO Reset	DMA Mode Select	Reserved	Reversed	RX Interrupt Active Level (LSB)	RX Interrupt Active Level (MSB)
+ 3	UART Control Register	UCR	Data Length Select Bit 0 (DLS0)	Data Length Select Bit 1 (DLS1)	Multiple Stop Bits Enable (MSBE)	Parity Bit Enable (PBE)	Even Parity Enable (EPE)	Parity Bit Fixed Enable (PBEFE)	Set Silence Enable (SSE)	Baudrate Divisor Latch Access Bit (BDLAB)
+ 4	Handshake Control Register	HCR	Data Terminal Ready (DTR)	Request to Send (RTS)	Loopback RI Input	IRQ Enable	Internal Loopback Enable	0	0	0
+ 5	UART Status Register	USR	RBR Data Ready (RDR)	Overrun Error (OER)	Parity Bit Error (PBER)	No Stop Bit Error (NSER)	Silent Byte Detected (SBD)	TBR Empty (TBRE)	TSR Empty (TSRE)	RX FIFO Error Indication (RFEI) **
+ 6	Handshake Status Register	HSR	CTS Toggling (TCTS)	DSR Toggling (TDSR)	RI Falling Edge (FERI)	DCD Toggling (TDCD)	Clear to Send (CTS)	Data Set Ready (DSR)	Ring Indicator (RI)	Data Carrier Detect (DCD)
+ 7	User Defined Register	UDR	Bit 0	Bit 1	Bit 2	Bit 3	Bit 4	Bit 5	Bit 6	Bit 7
+ 0 BDLAB = 1	Baudrate Divisor Latch Low	BLL	Bit 0	Bit 1	Bit 2	Bit 3	Bit 4	Bit 5	Bit 6	Bit 7
+ 1 BDLAB = 1	Baudrate Divisor Latch High	BHL	Bit 8	Bit 9	Bit 10	Bit 11	Bit 12	Bit 13	Bit 14	Bit 15

\*: Bit 0 is the least significant bit. The least significant bit is the first bit serially transmitted or received.

\*\* : These bits are always 0 in 16450 Mode.



### 11.2.2 UART Status Register (USR) (Read/Write)

This 8-bit register provides information about the status of data transfer during communication.

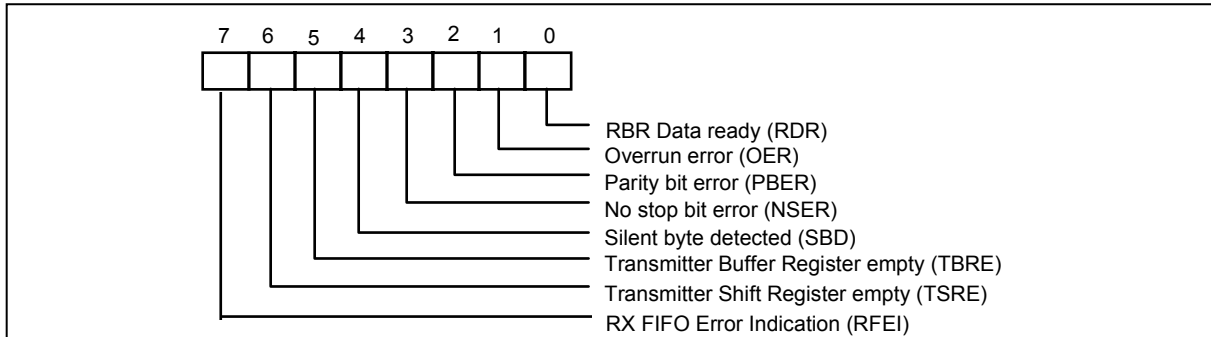

- Bit 7: RFEI. In 16450 mode, this bit is always set to logical 0. In 16550 mode, this bit is set to logical 1 when there is at least one parity-bit error and no stop-bit error or silent-byte detected in the FIFO. In 16550 mode, this bit is cleared to logical 0 by reading from the USR if there are no remaining errors left in the FIFO.
- Bit 6: TSRE. In 16450 mode, this bit is set to logical 1 when TBR and TSR are both empty. In 16550 mode, it is set to logical 1 when the transmit FIFO and TSR are both empty. Otherwise, this bit is set to logical 0.
- Bit 5: TBRE. In 16450 mode, when a data character is transferred from TBR to TSR, this bit is set to logical 1. If ETREI of ICR is high, an interrupt is generated to notify the CPU to write the next data. In 16550 mode, this bit is set to logical 1 when the transmit FIFO is empty. It is set to logical 0 when the CPU writes data into TBR or the FIFO.
- Bit 4: SBD. This bit is set to logical 1 to indicate that received data are kept in silent state for the time it takes to receive a full word, which includes the start bit, data bits, parity bit, and stop bits. In 16550 mode, it indicates the same condition for the data on the top of the FIFO. When the CPU reads USR, it sets this bit to logical 0.
- Bit 3: NSER. This bit is set to logical 1 to indicate that the received data have no stop bit. In 16550 mode, it indicates the same condition for the data on the top of the FIFO. When the CPU reads USR, it sets this bit to logical 0.
- Bit 2: PBER. This bit is set to logical 1 to indicate that the received data has the wrong parity bit. In 16550 mode, it indicates the same condition for the data on the top of the FIFO. When the CPU reads USR, it sets this bit to logical 0.
- Bit 1: OER. This bit is set to logical 1 to indicate that the received data have been overwritten by the next received data before they were read by the CPU. In 16550 mode, it indicates the same condition, instead of FIFO full. When the CPU reads USR, it sets this bit to logical 0.
- Bit 0: RDR. This bit is set to logical 1 to indicate that the received data are ready to be read by the CPU in the RBR or FIFO. When no data are left in the RBR or FIFO, the bit is set to logical 0.



### 11.2.3 Handshake Control Register (HCR) (Read/Write)

This register controls pins used with handshaking peripherals such as modems and also controls the diagnostic mode of the UART.

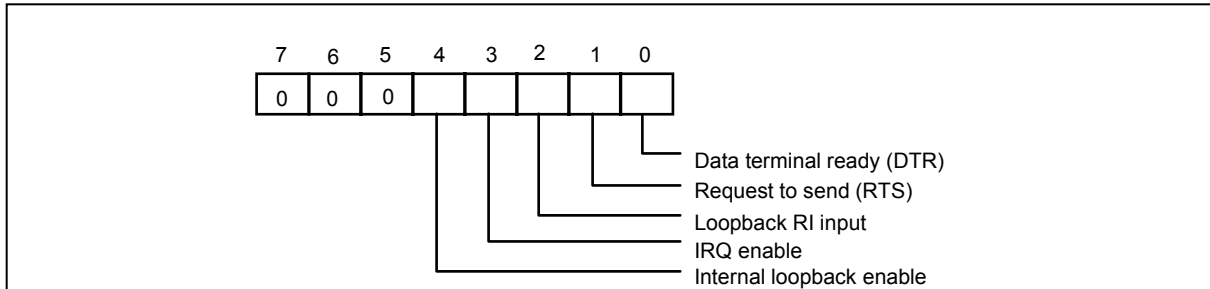

Bit 4: When this bit is set to logical 1, the UART enters diagnostic mode, as follows:

(1) SOUT is forced to logical 1, and SIN is isolated from the communication link.

(2) The modem output pins are set to their inactive state.

(3) The modem input pins are isolated from the communication link and connect internally as DTR (bit 0 of HCR) → DSR#, RTS (bit 1 of HCR) → CTS#, Loopback RI input (bit 2 of HCR) → RI# and IRQ enable (bit 3 of HCR) → DCD#.

Aside from the above connections, the UART operates normally. This method allows the CPU to test the UART in a convenient way.

Bit 3: The UART interrupt output is enabled by setting this bit to logical 1. In diagnostic mode, this bit is internally connected to the modem control input DCD#.

Bit 2: This bit is only used in the diagnostic mode. In diagnostic mode, this bit is internally connected to the modem control input RI#.

Bit 1: This bit controls the RTS# output. The value of this bit is inverted and output to RTS#.

Bit 0: This bit controls the DTR# output. The value of this bit is inverted and output to DTR#.

### 11.2.4 Handshake Status Register (HSR) (Read/Write)

This register reflects the current state of the four input pins used with handshake peripherals such as modems and records changes on these pins.

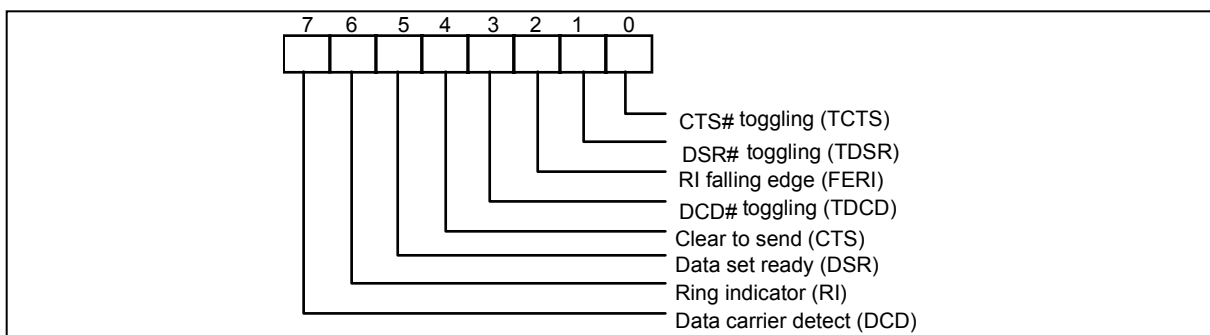

Bit 7: This bit is the opposite of the DCD# input. This bit is equivalent to bit 3 of HCR in loopback mode.

Bit 6: This bit is the opposite of the RI # input. This bit is equivalent to bit 2 of HCR in loopback mode.

Bit 5: This bit is the opposite of the DSR# input. This bit is equivalent to bit 0 of HCR in loopback mode.

Bit 4: This bit is the opposite of the CTS# input. This bit is equivalent to bit 1 of HCR in loopback mode.





Bit 3: TDCD. This bit indicates that the DCD# pin has changed state after HSR was read by the CPU.

Bit 2: FERI. This bit indicates that the RI # pin has changed from low to high after HSR was read by the CPU.

Bit 1: TDSR. This bit indicates that the DSR# pin has changed state after HSR was read by the CPU.

Bit 0: TCTS. This bit indicates that the CTS# pin has changed state after HSR was read by the CPU.

**11.2.5 UART FIFO Control Register (UFR) (Write only)**

This register is used to control the FIFO functions of the UART.

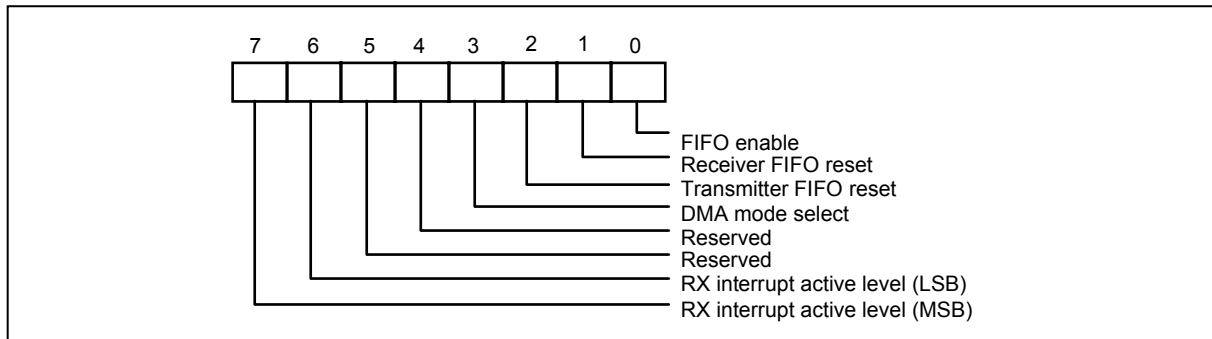

Bit 6, 7: These two bits are used to set the active level of the receiver FIFO interrupt. The active level is the number of bytes that must be in the receiver FIFO to generate an interrupt.

BIT 7	BIT 6	RX FIFO INTERRUPT ACTIVE LEVEL (BYTES)
0	0	01
0	1	04
1	0	08
1	1	14

Bit 4, 5: Reserved

Bit 3: When this bit is set to logical 1, DMA mode changes from mode 0 to mode 1 if UFR bit 0 = 1.

Bit 2: Setting this bit to logical 1 resets the TX FIFO counter logic to its initial state. This bit is automatically cleared afterwards.

Bit 1: Setting this bit to logical 1 resets the RX FIFO counter logic to its initial state. This bit is automatically cleared afterwards.

Bit 0: This bit enables 16550 (FIFO) mode. This bit should be set to logical 1 before the other UFR bits are programmed.



### 11.2.6 Interrupt Status Register (ISR) (Read only)

This register reflects the UART interrupt status.

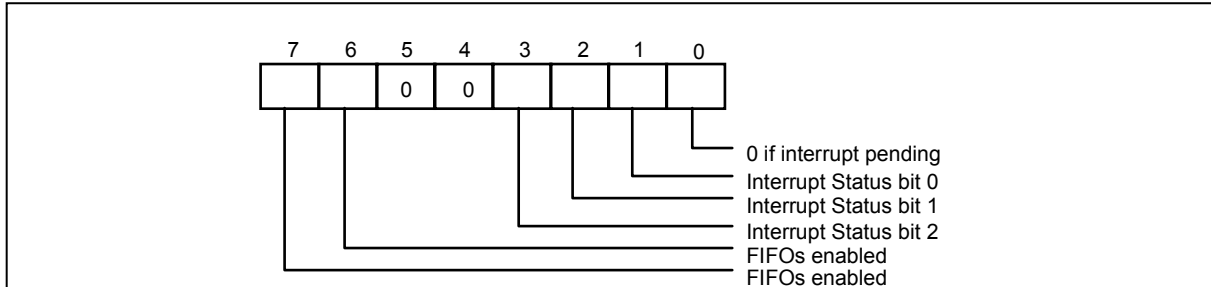

Bit 7, 6: These two bits are set to logical 1 when UFR, bit 0 = 1.

Bit 5, 4: These two bits are always logical 0.

Bit 3: In 16450 mode, this bit is logical 0. In 16550 mode, bits 3 and 2 are set to logical 1 when a time-out interrupt is pending. See the table below.

Bit 2, 1: These two bits identify the priority level of the pending interrupt, as shown in the table below.

Bit 0: This bit is logical 1 if there is no interrupt pending. If one of the interrupt sources has occurred, this bit is set to logical 0.

ISR				INTERRUPT SET AND FUNCTION			
Bit 3	Bit 2	Bit 1	Bit 0	Interrupt priority	Interrupt Type	Interrupt Source	Clear Interrupt
0	0	0	1	-	-	No Interrupt pending	-
0	1	1	0	First	UART Receive Status	1. OER = 1    2. PBER = 1 3. NSER = 1    4. SBD = 1	Read USR
0	1	0	0	Second	RBR Data Ready	1. RBR data ready 2. FIFO interrupt active level reached	1. Read RBR 2. Read RBR until FIFO data under active level
1	1	0	0	Second	FIFO Data Timeout	Data present in RX FIFO for 4 characters period of time since last access of RX FIFO.	Read RBR
0	0	1	0	Third	TBR Empty	TBR empty	1. Write data into TBR 2. Read ISR (if priority is third)
0	0	0	0	Fourth	Handshake status	1. TCTS = 1    2. TDSR = 1 3. FER1 = 1    4. TDCD = 1	Read HSR

\*\* Bit 3 of ISR is enabled when bit 0 of UFR is logical 1.



### 11.2.7 Interrupt Control Register (ICR) (Read/Write)

This 8-bit register enables and disables the five types of controller interrupts separately. A selected interrupt can be enabled by setting the appropriate bit to logical 1. The interrupt system can be totally disabled by setting bits 0 through 3 to logical 0.

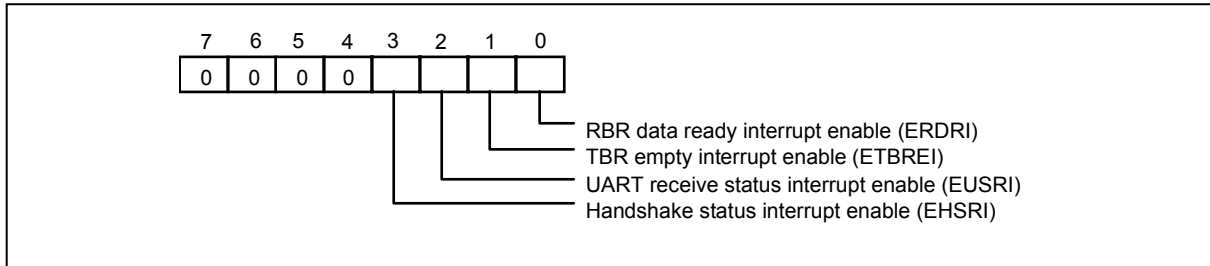

Bit 7-4: These four bits are always logical 0.

Bit 3: EHSRI. Set this bit to logical 1 to enable the handshake status register interrupt.

Bit 2: EUSRI. Set this bit to logical 1 to enable the UART status register interrupt.

Bit 1: ETBREI. Set this bit to logical 1 to enable the TBR empty interrupt.

Bit 0: ERDRI. Set this bit to logic 1 to enable the RBR data ready interrupt.

### 11.2.8 Programmable Baud Generator (BLL/BHL) (Read/Write)

Two 8-bit registers, BLL and BHL, compose a programmable baud generator that uses 24 MHz to generate a 1.8461 MHz frequency and divide it by a divisor from 1 to ( $2^{16} - 1$ ). The output frequency of the baud generator is the baud rate multiplied by 16, and this is the base frequency for the transmitter and receiver. The table below illustrates the use of the baud generator with a frequency of 1.8461 MHz. In high-speed UART mode (CROC, bits 7 and 6), the programmable baud generator directly uses 24 MHz and the same divisor as the normal speed divisor. As a result, in high-speed mode, the data transmission rate can be as high as 1.5M bps.

BAUD RATE FROM DIFFERENT PRE-DIVIDER				
PRE-DIV: 13 1.8461M HZ	PRE-DIV:1.625 14.769M HZ	PRE-DIV: 1.0 24M HZ	DECIMAL DIVISOR USED TO GENERATE 16X CLOCK	ERROR PERCENTAGE
50	400	650	2304	**
75	600	975	1536	**
110	880	1430	1047	0.18%
134.5	1076	1478.5	857	0.099%
150	1200	1950	768	**
300	2400	3900	384	**
600	4800	7800	192	**
1200	9600	15600	96	**
1800	14400	23400	64	**
2000	16000	26000	58	0.53%



Continued.

BAUD RATE FROM DIFFERENT PRE-DIVIDER				
PRE-DIV: 13 1.8461M HZ	PRE-DIV:1.625 14.769M HZ	PRE-DIV: 1.0 24M HZ	DECIMAL DIVISOR USED TO GENERATE 16X CLOCK	ERROR PERCENTAGE
2400	19200	31200	48	**
3600	28800	46800	32	**
4800	38400	62400	24	**
7200	57600	93600	16	**
9600	76800	124800	12	**
19200	153600	249600	6	**
38400	307200	499200	3	**
57600	460800	748800	2	**
115200	921600	1497600	1	**

\*\* Unless specified, the error percentage for all of the baud rates is 0.16%.

**Note:** Pre-Divisor is determined by CRF0 of UART A and B.

### 11.2.9 User-defined Register (UDR) (Read/Write)

This is a temporary register that can be accessed and defined by the user.



**12. PARALLEL PORT**

**12.1 Printer Interface Logic**

The W83627DHG parallel port can be attached to devices that accept eight bits of parallel data at standard TTL level. The W83627DHG supports the IBM XT/AT compatible parallel port (SPP), the bi-directional parallel port (BPP), the Enhanced Parallel Port (EPP), and the Extended Capabilities Parallel Port (ECP) on the parallel port.

The following tables show the pin definitions for different modes of the parallel port.

HOST CONNECTOR	PIN NUMBER OF W83627DHG	PIN ATTRIBUTE	SPP	EPP	ECP
1	36	O	nSTB	nWrite	nSTB, HostClk <sup>2</sup>
2-9	31-26, 24-23	I/O	PD<0:7>	PD<0:7>	PD<0:7>
10	22	I	nACK	Intr	nACK, PeriphClk <sup>2</sup>
11	21	I	BUSY	nWait	BUSY, PeriphAck <sup>2</sup>
12	19	I	PE	PE	PEerror, nAckReverse <sup>2</sup>
13	18	I	SLCT	Select	SLCT, Xflag <sup>2</sup>
14	35	O	nAFD	nDStrb	nAFD, HostAck <sup>2</sup>
15	34	I	nERR	nError	nFault <sup>1</sup> , nPeriphRequest <sup>2</sup>
16	33	O	nINIT	nInit	nINIT <sup>1</sup> , nReverseRqst <sup>2</sup>
17	32	O	nSLIN	nAStrb	nSLIN <sup>1</sup> , ECPMode <sup>2</sup>

**Notes:**

n<name > : Active Low

- 1. Compatible Mode
- 2. High Speed Mode
- 3. For more information, please refer to the IEEE 1284 standard.

HOST CONNECTOR	PIN NUMBER OF W83627DHG	PIN ATTRIBUTE	SPP
1	36	O	nSTB
2	31	I/O	PD0
3	30	I/O	PD1
4	29	I/O	PD2
5	28	I/O	PD3
6	27	I/O	PD4
7	26	I/O	PD5
8	24	I/O	PD6
9	23	I/O	PD7
10	22	I	nACK
11	21	I	BUSY



Continued

HOST CONNECTOR	PIN NUMBER OF W83627DHG	PIN ATTRIBUTE	SPP
12	19	I	PE
13	18	I	SLCT
14	35	O	nAFD
15	34	I	nERR
16	33	O	nINIT
17	32	O	nSLIN

## 12.2 Enhanced Parallel Port (EPP)

The following table lists the registers used in the EPP mode and identifies the bit map of the parallel port and EPP registers. Some of the registers are used in other modes as well.

A2	A1	A0	REGISTER	NOTE
0	0	0	Data port (R/W)	1
0	0	1	Printer status buffer (Read)	1
0	1	0	Printer control latch (Write)	1
0	1	0	Printer control swapper (Read)	1
0	1	1	EPP address port (R/W)	2
1	0	0	EPP data port 0 (R/W)	2
1	0	1	EPP data port 1 (R/W)	2
1	1	0	EPP data port 2 (R/W)	2
1	1	1	EPP data port 2 (R/W)	2

### Notes:

1. These registers are available in all modes.
2. These registers are available only in EPP mode.

REGISTER	7	6	5	4	3	2	1	0
Data Port (R/W)	PD7	PD6	PD5	PD4	PD3	PD2	PD1	PD0
Status Buffer (Read)	BUSY#	ACK#	PE	SLCT	ERROR#	1	1	TMOUT
Control Swapper (Read)	1	1	1	IRQEN	SLIN	INIT#	AUTOFD#	STROBE#
Control Latch (Write)	1	1	DIR	IRQ	SLIN	INIT#	AUTOFD#	STROBE#
EPP Address Port R/W)	PD7	PD6	PD5	PD4	PD3	PD2	PD1	PD0
EPP Data Port 0 (R/W)	PD7	PD6	PD5	PD4	PD3	PD2	PD1	PD0
EPP Data Port 1 (R/W)	PD7	PD6	PD5	PD4	PD3	PD2	PD1	PD0
EPP Data Port 2 (R/W)	PD7	PD6	PD5	PD4	PD3	PD2	PD1	PD0
EPP Data Port 3 (R/W)	PD7	PD6	PD5	PD4	PD3	PD2	PD1	PD0

Each register (or pair of registers, in some cases) is discussed below.



### 12.2.1 Data Port (Data Swapper)

The CPU reads the contents of the printer's data latch by reading the data port.

### 12.2.2 Printer Status Buffer

The CPU reads the printer status by reading the printer status buffer. The bit definitions are as follows:

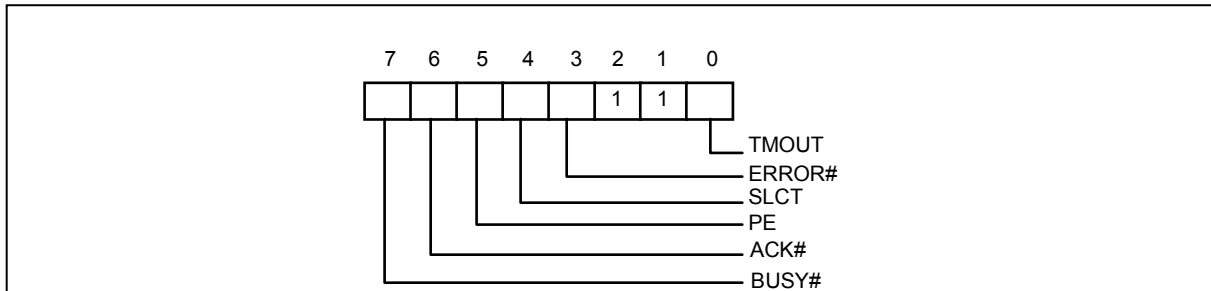

**Bit 7:** This signal is active during data entry, when the printer is off-line during printing, when the print head is changing position, or in an error state. When this signal is active, the printer is busy and cannot accept data.

**Bit 6:** This bit represents the current state of the printer's ACK# signal. A logical 0 means the printer has received a character and is ready to accept another. Normally, this signal is active for approximately 5  $\mu$ s before BUSY# stops.

**Bit 5:** A logical 1 means the printer has detected the end of paper.

**Bit 4:** A logical 1 means the printer is selected.

**Bit 3:** A logical 0 means the printer has encountered an error condition.

**Bit 1, 2:** Reserved. These two bits are always read as logical 1.

**Bit 0:** This bit is only valid in EPP mode. A logical 1 indicates that a 10- $\mu$ s time-out has occurred on the EPP bus; a logical 0 means that no time-out error has occurred. Writing a logical 1 to this bit clears the time-out status bit; writing a logical 0 has no effect.

### 12.2.3 Printer Control Latch and Printer Control Swapper

The CPU reads the contents of the printer control latch by reading the printer control swapper. The bit definitions are as follows:

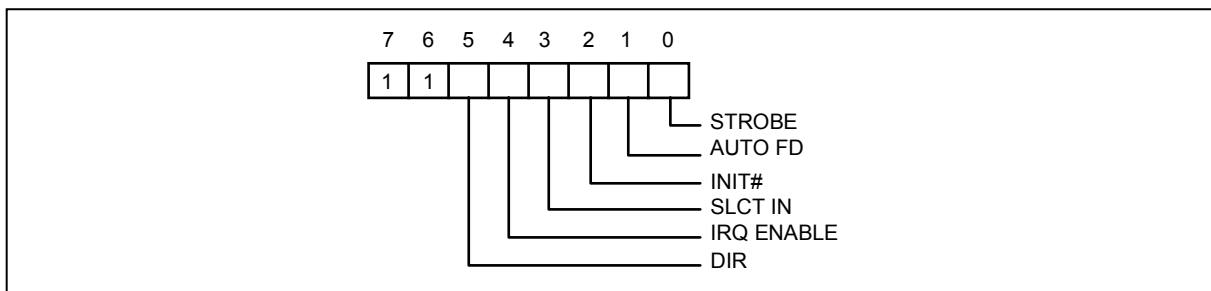

**Bit 7, 6:** These two bits are always read as logical 1. They can be written.

**Bit 5:** Direction control bit



When this bit is logical 1, the parallel port is in input mode (read); when it is logical 0, the parallel port is in output mode (write). This bit can be read and written. In SPP mode, this bit is invalid and fixed at zero.

Bit 4: A logical 1 allows an interrupt to occur when ACK# changes from low to high.

Bit 3: A logical 1 selects the printer.

Bit 2: A logical 0 starts the printer (50 microsecond pulse, minimum).

Bit 1: A logical 1 causes the printer to line-feed after a line is printed.

Bit 0: A logical 1 generates an active-high pulse for a minimum of 0.5 $\mu$ s to clock data into the printer. Valid data must be present for a minimum of 0.5 $\mu$ s before and after the strobe pulse.

#### 12.2.4 EPP Address Port

The address port is available only in EPP mode. Bit definitions are as follows:

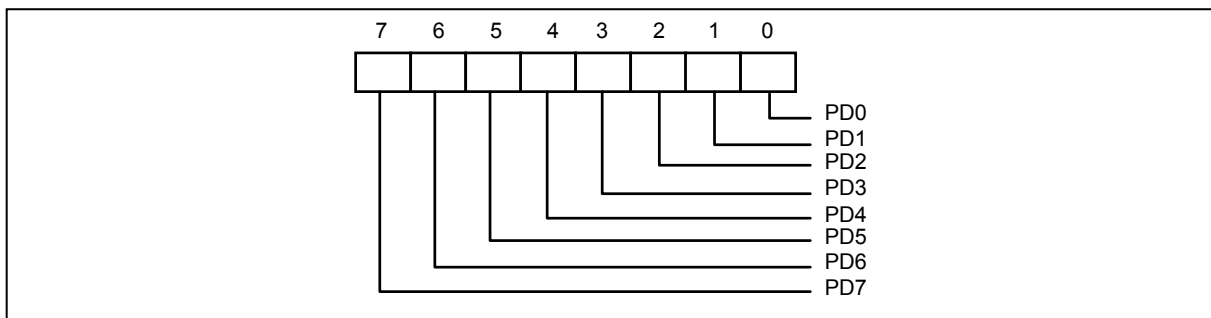

The contents of DB0-DB7 are buffered (non-inverting) and output to ports PD0-PD7 during a write operation. The leading edge of IOW# causes an EPP address write cycle to be performed, and the trailing edge of IOW# latches the data for the duration of the EPP write cycle.

PD0-PD7 ports are read during a read operation. The leading edge of IOR# causes an EPP address read cycle to be performed and the data to be output to the host CPU.

#### 12.2.5 EPP Data Port 0-3

These four registers are available only in EPP mode. The bit definitions for each data port are the same and as follows:

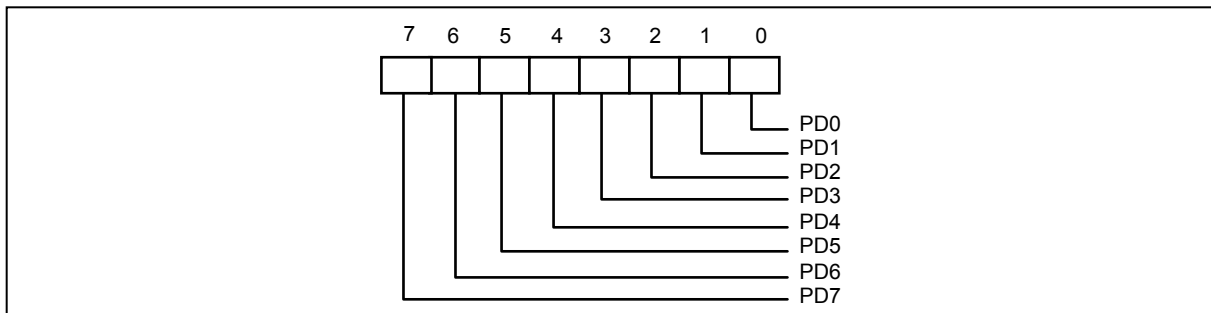





When any EPP data port is accessed, the contents of DB0-DB7 are buffered (non-inverting) and output to ports PD0-PD7 during a write operation. The leading edge of IOW# causes an EPP data write cycle to be performed, and the trailing edge of IOW# latches the data for the duration of the EPP write cycle. During a read operation, ports PD0-PD7 are read, and the leading edge of IOR# causes an EPP read cycle to be performed and the data to be output to the host CPU.

### 12.2.6 EPP Pin Descriptions

EPP NAME	TYPE	EPP DESCRIPTION
NWrite	O	Denotes read or write operation for address or data.
PD<0:7>	I/O	Bi-directional EPP address and data bus.
Intr	I	Used by peripheral device to interrupt the host.
NWait	I	Inactivated to acknowledge that data transfer is complete. Activated to indicate that the device is ready for the next transfer.
PE	I	Paper end; same as SPP mode.
Select	I	Printer-select status; same as SPP mode.
NDStrb	O	This signal is active low. It denotes a data read or write operation.
Nerror	I	Error; same as SPP mode.
Ninits	O	This signal is active low. When it is active, the EPP device is reset to its initial operating mode.
NAStrb	O	This signal is active low. It denotes an address read or write operation.

### 12.2.7 EPP Operation

When EPP mode is selected, the PDx bus is in standard or bi-directional mode when no EPP read, write, or address cycle is being executed. In this situation, all output signals are set by the SPP Control Port and the direction is controlled by DIR of the Control Port.

A watchdog timer is required to prevent system lockup. The timer indicates that more than 10  $\mu$ s have elapsed from the start of the EPP cycle to the time WAIT# is deasserted. The current EPP cycle is aborted when a time-out occurs. The time-out condition is indicated in status bit 0.

The EPP operates on a two-phase cycle. First, the host selects the register within the device for subsequent operations. Second, the host performs a series of read and/or write byte operations to the selected register. Four operations are supported on the EPP: Address Write, Data Write, Address Read, and Data Read. All operations on the EPP device are performed asynchronously.

#### 12.2.7.1. EPP Version 1.9 Operation

The EPP read/write operation can be completed under the following conditions:

- a. If nWait is active low, the read cycle (nWrite inactive high, nDStrb/nAStrb active low) or write cycle (nWrite active low, nDStrb/nAStrb active low) starts, proceeds normally, and is completed when nWait goes inactive high.
- b. If nWait is inactive high, the read/write cycle cannot start. It must wait until nWait changes to active low, at which time it starts as described above.



### 12.2.7.2. EPP Version 1.7 Operation

The EPP read/write cycle can start without checking whether nWait is active or inactive. Once the read/write cycle starts; however, it does not finish until nWait changes from active low to inactive high.

## 12.3 Extended Capabilities Parallel (ECP) Port

This port is software- and hardware-compatible with existing parallel ports, so the W83627DHG parallel port may be used in standard printer mode if ECP is not required. It provides an automatic high burst-bandwidth channel that supports DMA for ECP in both the forward (host-to-peripheral) and reverse (peripheral-to-host) directions.

Small FIFOs are used in both forward and reverse directions to improve the maximum bandwidth requirement. The size of the FIFO is 16 bytes. The ECP port supports an automatic handshake for the standard parallel port to improve compatibility mode transfer speed.

The ECP port hardware supports run-length-encoded (RLE) decompression. Compression is accomplished by counting identical bytes and transmitting an RLE byte that indicates how many times the next byte is to be repeated. RLE compression is required; the hardware support is optional.

For more information about the ECP Protocol, please refer to the Extended Capabilities Port Protocol and ISA Interface Standard.

The W83627DHG ECP supports the following modes.

MODE	DESCRIPTION
000	SPP mode
001	PS/2 Parallel Port mode
010	Parallel Port Data FIFO mode
011	ECP Parallel Port mode
100	EPP mode (If this option is enabled in the CRF0 to select ECP/EPP mode)
101	Reserved
110	Test mode
111	Configuration mode

The mode selection bits are bits 7-5 of the Extended Control Register.



### 12.3.1 ECP Register and Bit Map

The next two tables list the registers used in the ECP mode and provide a bit map of the parallel port and ECP registers.

NAME	ADDRESS	I/O	ECP MODES	FUNCTION
data	Base+000h	R/W	000-001	Data Register
ecpAFifo	Base+000h	R/W	011	ECP FIFO (Address)
dSr	Base+001h	R	All	Status Register
dCr	Base+002h	R/W	All	Control Register
cFifo	Base+400h	R/W	010	Parallel Port Data FIFO
ecpDFifo	Base+400h	R/W	011	ECP FIFO (DATA)
tFifo	Base+400h	R/W	110	Test FIFO
cnfgA	Base+400h	R	111	Configuration Register A
cnfgB	Base+401h	R/W	111	Configuration Register B
ecr	Base+402h	R/W	All	Extended Control Register

**Note:** The base addresses are specified by CR60 and 61, which are determined by the configuration register or the hardware setting.

	D7	D6	D5	D4	D3	D2	D1	D0	NOTE
Data	PD7	PD6	PD5	PD4	PD3	PD2	PD1	PD0	
ecpAFifo	Addr/RLE	Address or RLE field							2
Dsr	nBusy	nAck	PErr	Select	nFault	1	1	1	1
Dcr	1	1	Directio	ackIntEn	SelectIn	nIntr	autofd	strobe	1
cFifo	Parallel Port Data FIFO								2
ecpDFifo	ECP Data FIFO								2
tFifo	Test FIFO								2
cnfgA	0	0	0	1	0	0	0	0	
cnfgB	compress	intrValue	1	1	1	1	1	1	
Ecr	MODE			nErrIntrEn	dmaEn	serviceIntr	full	empty	

**Notes:**

1. These registers are available in all modes.
2. All FIFOs use one common 16-byte FIFO.

Each register (or pair of registers, in some cases) is discussed below.



**12.3.2 Data and ecpAFifo Port**

Modes 000 (SPP) and 001 (PS/2) (Data Port)

During a write operation, the Data Register latches the contents of the data bus on the rising edge of the input, and the contents of this register are output to PD0-PD7. During a read operation, ports PD0-PD7 are read and output to the host. The bit definitions are as follows:

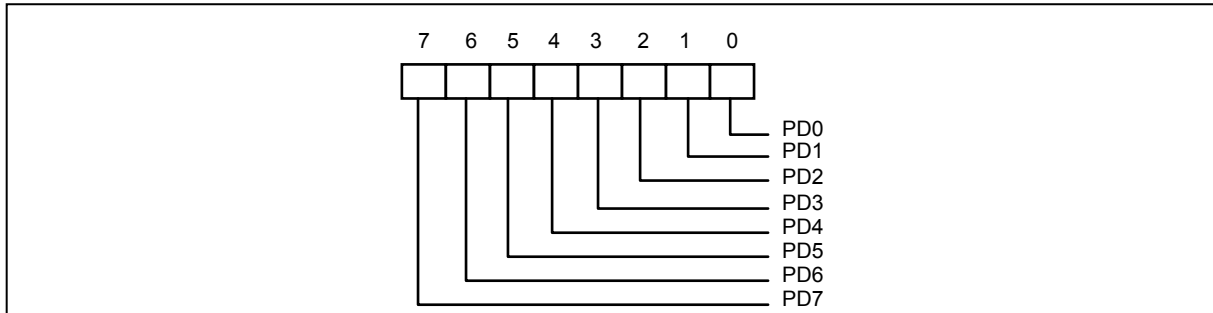

Mode 011 (ECP FIFO-Address/RLE)

A data byte written to this address is placed in the FIFO and tagged as an ECP Address/RLE. The hardware at the ECP port transmits this byte to the peripheral automatically. This operation is defined only for the forward direction. The bit definitions are as follows:

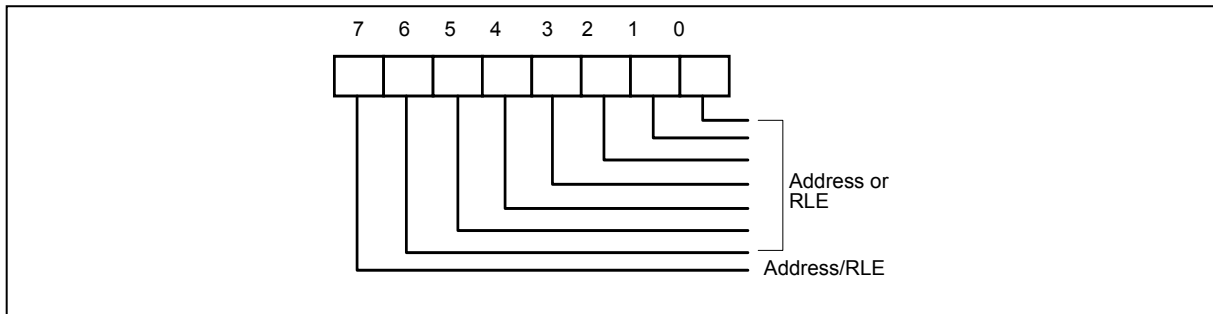

**12.3.3 Device Status Register (DSR)**

These bits are logical 0 during a read of the Printer Status Register. The bits of this status register are defined as follows:

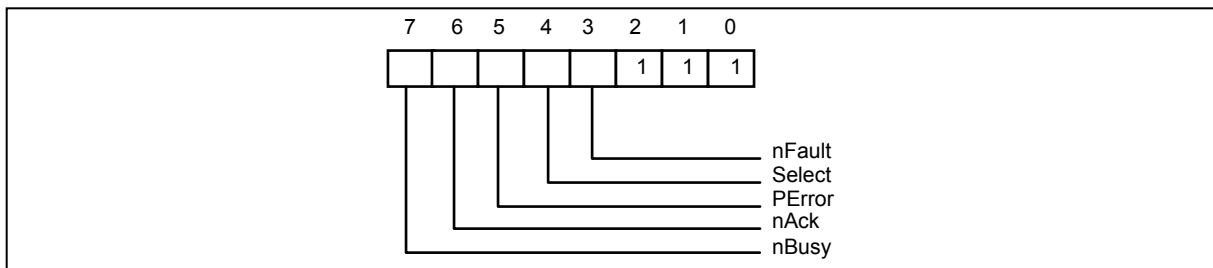



Bit 7: This bit reflects the complement of the Busy input.

Bit 6: This bit reflects the nAck input.

Bit 5: This bit reflects the PError input.

Bit 4: This bit reflects the Select input.

Bit 3: This bit reflects the nFault input.

Bit 2-0: These three bits are not implemented and are always logical 1 during a read.

### 12.3.4 Device Control Register (DCR)

The bit definitions are as follows:

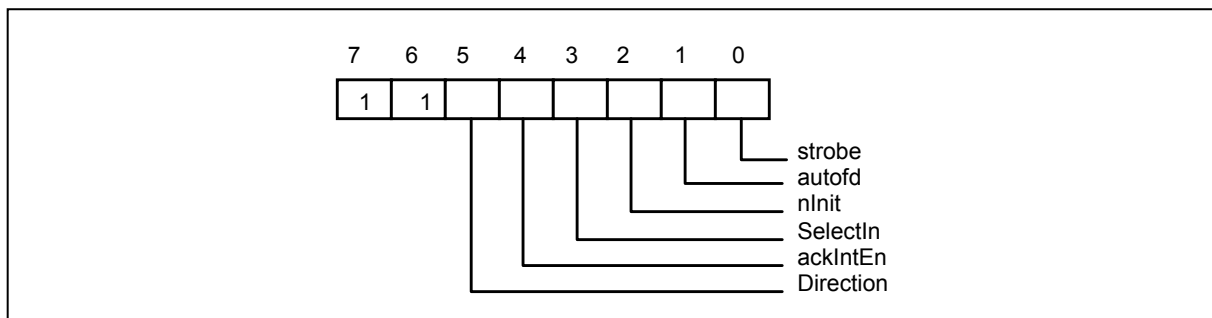

Bit 7, 6: These two bits are always read as logical one and cannot be written.

Bit 5: If the mode is 000 or 010, this bit has no effect and the direction is always out. In other modes,  
 0 the parallel port is in output mode.  
 1 the parallel port is in input mode.

Bit 4: Interrupt request enable. When this bit is set to logical 1, it enables interrupt requests from the parallel port to the CPU on the low-to-high transition on ACK#.

Bit 3: This bit is inverted and output to the SLIN# output.

0 The printer is not selected.  
 1 The printer is selected.

Bit 2: This bit is output to the INIT# output.

Bit 1: This bit is inverted and output to the AFD# output.

Bit 0: This bit is inverted and output to the STB# output.

### 12.3.5 CFIFO (Parallel Port Data FIFO) Mode = 010

This mode is defined only for the forward direction. Bytes written or DMAed to this FIFO are transmitted by a hardware handshake to the peripheral using the standard parallel port protocol. Transfers to the FIFO are byte-aligned.

### 12.3.6 ECPDFIFO (ECP Data FIFO) Mode = 011

When the direction bit is 0, bytes written or DMAed to this FIFO are transmitted by a hardware handshake to the peripheral using the ECP parallel port protocol. Transfers to the FIFO are byte-aligned.

When the direction bit is 1, data bytes from the peripheral are read via automatic hardware handshake from ECP into this FIFO. Reads or DMAs from the FIFO return bytes of ECP data to the system.



### 12.3.7 TFIFO (Test FIFO Mode) Mode = 110

Data bytes may be read, written, or DMAed to or from the system to this FIFO in any direction. Data in the tFIFO is not transmitted to the parallel port lines. However, data in the tFIFO may be displayed on the parallel port data lines.

### 12.3.8 CNFGA (Configuration Register A) Mode = 111

This register is a read-only register. When it is read, 10h is returned indicating an 8-bit implementation.

### 12.3.9 CNFGB (Configuration Register B) Mode = 111

The bit definitions are as follows:

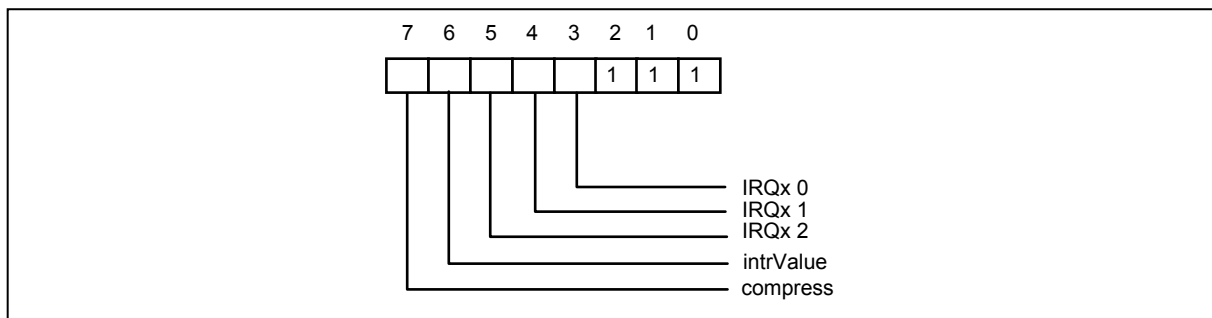

Bit 7: This bit is read-only. It is logical 0 during a read, which means that this chip does not support hardware RLE compression.

Bit 6: Returns the value on the ISA IRQ line to determine possible conflicts.

Bit 5-3: Reflects the IRQ resource assigned for ECP port.

CNFGB[5:3]	IRQ RESOURCE
000	Reflects other IRQ resources selected by PnP register (default)
001	IRQ7
010	IRQ9
011	IRQ10
100	IRQ11
101	IRQ14
110	IRQ15
111	IRQ5

Bit 2-0: These five bits are logical 1 during a read and can be written.



### 12.3.10 ECR (Extended Control Register) Mode = all

This register controls the extended ECP parallel port functions. The bit definitions are follows:

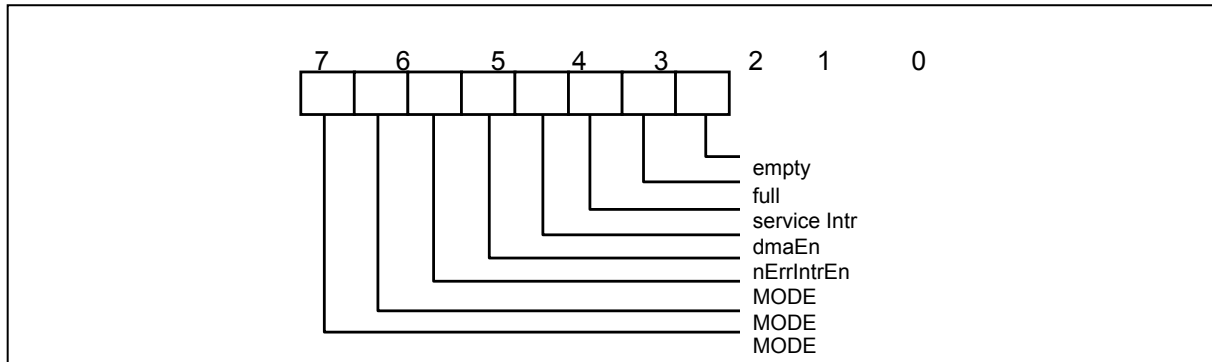

Bit 7-5: Read/Write. These bits select the mode.

- 000 Standard Parallel Port (SPP) mode. The FIFO is reset in this mode.
- 001 PS/2 Parallel Port mode. In addition to the functions of the SPP mode, this mode has an extra trait: Direction is able to tri-state the data lines. Furthermore, reading the data register returns the value on the data lines, not the value in the data register.
- 010 Parallel Port FIFO mode. This is the same as SPP mode except that bytes are written or DMAed to the FIFO. FIFO data are automatically transmitted using the standard parallel port protocol. This mode functions only when direction is 0.
- 011 ECP Parallel Port Mode. When the direction is 0 (forward direction), bytes placed into the `ecpDFifo` and bytes written to the `ecpAFifo` are placed in a single FIFO and automatically transmitted to the peripheral using the ECP Protocol. When the direction is 1 (reverse direction), bytes are moved from the ECP parallel port and packed into bytes in the `ecpDFifo`.
- 100 EPP Mode. EPP mode is activated if the EPP mode is selected.
- 101 Reserved.
- 110 Test Mode. The FIFO may be written and read in this mode, but the data is not transmitted on the parallel port.
- 111 Configuration Mode. The `cfgA` and `cfgB` registers are accessible at 0x400 and 0x401 in this mode.

Bit 4: Read/Write (Valid only in ECP Mode)

- 1 Disables the interrupt generated on the asserting edge of `nFault`.
- 0 Enables the interrupt generated on the falling edge of `nFault`. This prevents interrupts from being lost in the time between the read of the ECR and the write of the ECR.

Bit 3: Read/Write

- 1 Enables DMA.
- 0 Disables DMA unconditionally.



## Bit 2: Read/Write

- 1 Disables DMA and all of the service interrupts. Writing a logical 1 to this bit does not cause an interrupt.
- 0 Enables one of the following cases of interrupts. When one of the serviced interrupts occurs, this bit is set to logical 1 by the hardware. This bit must be reset to logical 0 to re-enable the interrupts.
  - (a) dmaEn = 1: During DMA, this bit is set to logical 1 when terminal count is reached.
  - (b) dmaEn = 0, direction = 0: This bit is set to logical 1 whenever there are writeIntr threshold or more bytes free in the FIFO.
  - (c) dmaEn = 0, direction = 1: This bit is set to logical 1 whenever there are readIntr threshold or more valid bytes to be read from the FIFO.

## Bit 1: Read only

- 0 The FIFO has at least one free byte.
- 1 The FIFO is completely full; it cannot accept another byte.

## Bit 0: Read only

- 0 The FIFO contains at least one byte of data.
- 1 The FIFO is completely empty.

## 12.3.11 ECP Pin Descriptions

NAME	TYPE	DESCRIPTION
NStrobe (HostClk)	O	This pin loads data or address into the slave on its asserting edge during write operations. This signal handshakes with Busy.
PD<7:0>	I/O	These signals contain address, data or RLE data.
nAck (PeriphClk)	I	This signal indicates valid data driven by the peripheral when asserted. This signal handshakes with nAutoFd in reverse.
Busy (PeriphAck)	I	This signal deasserts to indicate that the peripheral can accept data. In the reverse direction, it indicates whether the data lines contain ECP command information or data. Normal data are transferred when Busy (PeriphAck) is high, and an 8-bit command is transferred when it is low.
PError (nAckReverse)	I	This signal is used to acknowledge a change in the direction of the transfer (asserted = forward). The peripheral drives this signal low to acknowledge nReverseRequest. The host relies upon nAckReverse to determine when it is permitted to drive the data bus.
Select (Xflag)	I	Indicates printer on-line.





ECP Pin Descriptions , continued.

NAME	TYPE	DESCRIPTION
NautoFd (HostAck)	O	Requests a byte of data from the peripheral when it is asserted. In the forward direction, this signal indicates whether the data lines contain ECP address or data. Normal data are transferred when nAutoFd (HostAck) is high, and an 8-bit command is transferred when it is low.
nFault (nPeriphReuquest)	I	Generates an error interrupt when it is asserted. This signal is valid only in the forward direction. The peripheral is permitted (but not required) to drive this pin low to request a reverse transfer during ECP mode.
nInit (nReverseRequest)	O	This signal sets the transfer direction (asserted = reverse, deasserted = forward). This pin is driven low to place the channel in the reverse direction.
nSelectIn (ECPMode)	O	This signal is always deasserted in ECP mode.

### 12.3.12 ECP Operation

The host must negotiate on the parallel port to determine if the peripheral supports the ECP protocol before ECP operation. After negotiation, it is necessary to initialize some of the port bits.

- (a) Set direction = 0, enabling the drivers.
- (b) Set strobe = 0, causing the nStrobe signal to default to the deasserted state.
- (c) Set autoFd = 0, causing the nAutoFd signal to default to the deasserted state.
- (d) Set mode = 011 (ECP Mode)

ECP address/RLE bytes or data bytes may be sent automatically by writing the ecpAFifo or ecpDFifo, respectively.

#### 12.3.12.1. Mode Switching

The software must handle P1284 negotiation and all operations prior to a data transfer in SPP or PS/2 modes (000 or 001). The hardware provides an automatic control line handshake, moving data between the FIFO and the ECP port, only in the data transfer phase (mode 011 or 010).

If the port is in mode 000 or 001, it may switch to any other mode. If the port is not in mode 000 or 001, it can only be switched into mode 000 or 001. The direction can only be changed in mode 001.

In extended forward mode, the software should wait for the FIFO to be empty before switching back to mode 000 or 001. In ECP reverse mode, the software should wait for all the data to be read from the FIFO before changing back to mode 000 or 001.

#### 12.3.12.2. Command/Data

ECP mode allows the transfer of normal 8-bit data or 8-bit commands. In the forward direction, normal data are transferred when HostAck is high, and an 8-bit command is transferred when HostAck is low. The most significant bits of the command indicate whether it is a run-length count (for compression) or a channel address.

In the reverse direction, normal data are transferred when PeriphAck is high, and an 8-bit command is transferred when PeriphAck is low. The most significant bit of the command is always zero.



### **12.3.12.3. Data Compression**

The W83627DHG hardware supports RLE decompression and can transfer compressed data to a peripheral. Odd (RLE) compression is not supported in the hardware, however. In order to transfer data in ECP mode, the compression count is written to ecpAFifo and the data byte is written to ecpDFifo.

### **12.3.13 FIFO Operation**

The FIFO threshold is set in LD0 CRO0, bit 6 ~ 3. All data transferred to or from the parallel port can proceed in DMA or Programmed I/O (non-DMA) mode, as indicated by the selected mode. The FIFO is used in Parallel Port FIFO mode or ECP Parallel Port Mode. After a reset, the FIFO is disabled.

### **12.3.14 DMA Transfers**

DMA transfers are always to or from the ecpDFifo, tFifo, or CFifo. DMA uses the standard PC DMA services. The ECP requests DMA transfers from the host by activating the PDRQ pin. The DMA empties or fills the FIFO using the appropriate direction and mode. When the terminal count in the DMA controller is reached, an interrupt is generated, and serviceIntr is asserted, which will disable the DMA.

### **12.3.15 Programmed I/O (NON-DMA) Mode**

The ECP and parallel port FIFOs can also be operated using interrupt-driven, programmed I/O. Programmed I/O transfers are

1. To the ecpDFifo at 400h and ecpAFifo at 000h
2. From the ecpDFifo located at 400h
3. To / from the tFifo at 400h.

The host must set dmaEn and serviceIntr to 0 and also must set the direction and state accordingly in the programmed I/O transfers.

The ECP requests programmed I/O transfers from the host by activating the IRQ pin. The programmed I/O empties or fills the FIFO using the appropriate direction and mode.



### 13. KEYBOARD CONTROLLER

The W83627DHG KBC (8042 with licensed KB BIOS) circuit is designed to provide the functions needed to interface a CPU with a keyboard and/or a PS/2 mouse and can be used with IBM®-compatible personal computers or PS/2-based systems. The controller receives serial data from the keyboard or PS/2 mouse, checks the parity of the data, and presents the data to the system as a byte of data in its output buffer. Then, the controller asserts an interrupt to the system when data are placed in its output buffer. The keyboard and PS/2 mouse are required to acknowledge all data transmissions. No transmission should be sent to the keyboard or PS/2 mouse until an acknowledgement is received for the previous data byte.

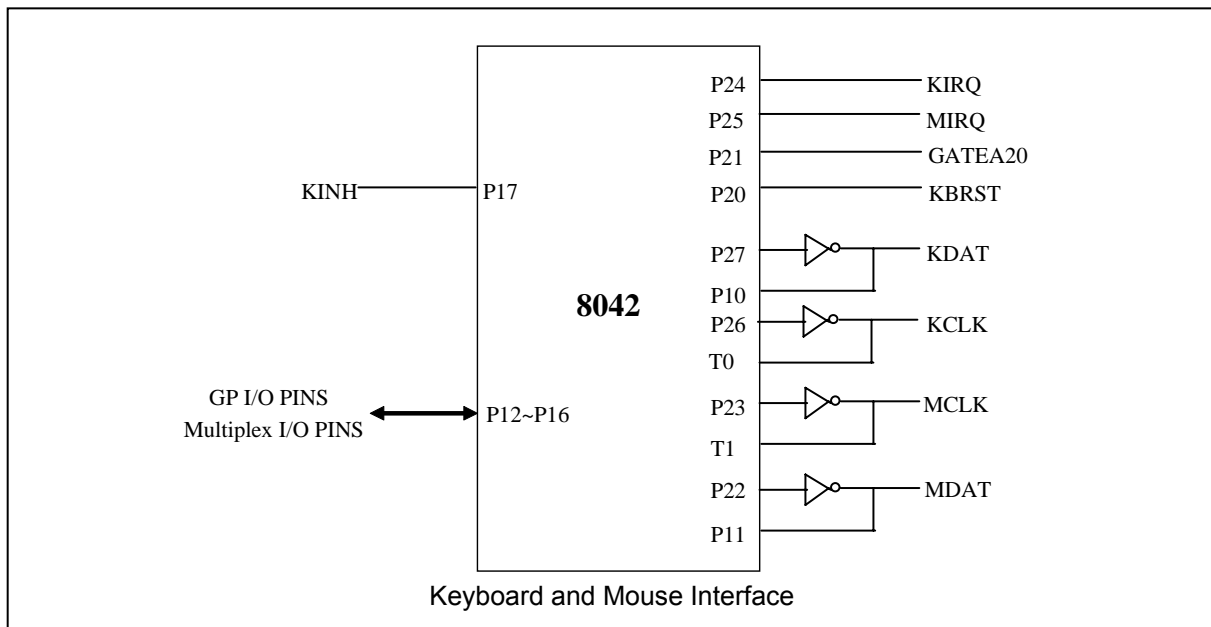

#### 13.1 Output Buffer

The output buffer is an 8-bit, read-only register at I/O address 60h (Default, PnP programmable I/O address LD5-CR60 and LD5-CR61). The keyboard controller uses the output buffer to send the scan code (from the keyboard) and required command bytes to the system. The output buffer can only be read when the output buffer full bit in the register (in the status register) is logical 1.

#### 13.2 Input Buffer

The input buffer is an 8-bit, write-only register at I/O address 60h or 64h (Default, PnP programmable I/O address LD5-CR60, LD5-CR61, LD5-CR62, and LD5-CR63). Writing to address 60h sets a flag to indicate a data write; writing to address 64h sets a flag to indicate a command write. Data written to I/O address 60h is sent to the keyboard (unless the keyboard controller is expecting a data byte) through the controller's input buffer only if the input buffer full bit (in the status register) is logical 0.



### 13.3 Status Register

The status register is an 8-bit, read-only register at I/O address 64h (Default, PnP programmable I/O address LD5-CR62 and LD5-CR63) that holds information about the status of the keyboard controller and interface. It may be read at any time.

BIT	BIT FUNCTION	DESCRIPTION
0	Output Buffer Full	0: Output buffer empty 1: Output buffer full
1	Input Buffer Full	0: Input buffer empty 1: Input buffer full
2	System Flag	This bit may be set to 0 or 1 by writing to the system flag bit in the command byte of the keyboard controller. It defaults to 0 after a power-on reset.
3	Command/Data	0: Data byte 1: Command byte
4	Inhibit Switch	0: Keyboard is inhibited 1: Keyboard is not inhibited
5	Auxiliary Device Output Buffer	0: Auxiliary device output buffer empty 1: Auxiliary device output buffer full
6	General Purpose Time-out	0: No time-out error 1: Time-out error
7	Parity Error	0: Odd parity 1: Even parity (error)

### 13.4 Commands

COMMAND	FUNCTION																		
20h	Read Command Byte of Keyboard Controller																		
60h	Write Command Byte of Keyboard Controller <table border="1" data-bbox="607 1367 1192 1738"> <thead> <tr> <th>BIT</th> <th>BIT DEFINITION</th> </tr> </thead> <tbody> <tr> <td>7</td> <td>Reserved</td> </tr> <tr> <td>6</td> <td>IBM Keyboard Translate Mode</td> </tr> <tr> <td>5</td> <td>Disable Auxiliary Device</td> </tr> <tr> <td>4</td> <td>Disable Keyboard</td> </tr> <tr> <td>3</td> <td>Reserve</td> </tr> <tr> <td>2</td> <td>System Flag</td> </tr> <tr> <td>1</td> <td>Enable Auxiliary Interrupt</td> </tr> <tr> <td>0</td> <td>Enable Keyboard Interrupt</td> </tr> </tbody> </table>	BIT	BIT DEFINITION	7	Reserved	6	IBM Keyboard Translate Mode	5	Disable Auxiliary Device	4	Disable Keyboard	3	Reserve	2	System Flag	1	Enable Auxiliary Interrupt	0	Enable Keyboard Interrupt
BIT	BIT DEFINITION																		
7	Reserved																		
6	IBM Keyboard Translate Mode																		
5	Disable Auxiliary Device																		
4	Disable Keyboard																		
3	Reserve																		
2	System Flag																		
1	Enable Auxiliary Interrupt																		
0	Enable Keyboard Interrupt																		



Commands, continued

COMMAND	FUNCTION												
A4h	Test Password Returns 0Fah if Password is loaded Returns 0F1h if Password is not loaded												
A5h	Load Password Load Password until a logical 0 is received from the system												
A6h	Enable Password Enable the checking of keystrokes for a match with the password												
A7h	Disable Auxiliary Device Interface												
A8h	Enable Auxiliary Device Interface												
A9h	Interface Test <table border="1" data-bbox="607 751 1248 984"> <thead> <tr> <th>BIT</th> <th>BIT DEFINITION</th> </tr> </thead> <tbody> <tr> <td>00</td> <td>No Error Detected</td> </tr> <tr> <td>01</td> <td>Auxiliary Device "Clock" line is stuck low</td> </tr> <tr> <td>02</td> <td>Auxiliary Device "Clock" line is stuck high</td> </tr> <tr> <td>03</td> <td>Auxiliary Device "Data" line is stuck low</td> </tr> <tr> <td>04</td> <td>Auxiliary Device "Data" line is stuck low</td> </tr> </tbody> </table>	BIT	BIT DEFINITION	00	No Error Detected	01	Auxiliary Device "Clock" line is stuck low	02	Auxiliary Device "Clock" line is stuck high	03	Auxiliary Device "Data" line is stuck low	04	Auxiliary Device "Data" line is stuck low
BIT	BIT DEFINITION												
00	No Error Detected												
01	Auxiliary Device "Clock" line is stuck low												
02	Auxiliary Device "Clock" line is stuck high												
03	Auxiliary Device "Data" line is stuck low												
04	Auxiliary Device "Data" line is stuck low												
AAh	Self-test Returns 055h if self-test succeeds												
ABh	Interface Test <table border="1" data-bbox="592 1102 1274 1335"> <thead> <tr> <th>BIT</th> <th>BIT DEFINITION</th> </tr> </thead> <tbody> <tr> <td>00</td> <td>No Error Detected</td> </tr> <tr> <td>01</td> <td>Keyboard "Clock" line is stuck low</td> </tr> <tr> <td>02</td> <td>Keyboard "Clock" line is stuck high</td> </tr> <tr> <td>03</td> <td>Keyboard "Data" line is stuck low</td> </tr> <tr> <td>04</td> <td>Keyboard "Data" line is stuck high</td> </tr> </tbody> </table>	BIT	BIT DEFINITION	00	No Error Detected	01	Keyboard "Clock" line is stuck low	02	Keyboard "Clock" line is stuck high	03	Keyboard "Data" line is stuck low	04	Keyboard "Data" line is stuck high
BIT	BIT DEFINITION												
00	No Error Detected												
01	Keyboard "Clock" line is stuck low												
02	Keyboard "Clock" line is stuck high												
03	Keyboard "Data" line is stuck low												
04	Keyboard "Data" line is stuck high												
ADh	Disable Keyboard Interface												
AEh	Enable Keyboard Interface												
C0h	Read Input Port (P1) and send data to the system												
C1h	Continuously puts the lower four bits of Port1 into the STATUS register												
C2h	Continuously puts the upper four bits of Port1 into the STATUS register												
D0h	Send Port 2 value to the system												
D1h	Only set / reset GateA20 line based on system data bit 1												
D2h	Send data back to the system as if it came from the Keyboard												
D3h	Send data back to the system as if it came from Auxiliary Device												
D4h	Output next received byte of data from system to Auxiliary Device												
E0h	Reports the status of the test inputs												
FXh	Pulse only RC (the reset line) low for 6 $\mu$ s if the Command byte is even												



### 13.5 Hardware GATEA20/Keyboard Reset Control Logic

The KBC includes hardware control logic to speed-up GATEA20 and KBRESET. This control logic is controlled by LD5-CRF0 as follows:

#### 13.5.1 KB Control Register

BIT	7	6	5	4	3	2	1	0
NAME	KCLKS1	KCLKS0	Reserved	Reserved	Reserved	P92EN	HGA20	HKBRST

#### KCLKS1, KCLKS0

These two bits select the KBC clock rate.

- 00: KBC clock input is 6 MHz
- 01: KBC clock input is 8 MHz
- 10: KBC clock input is 12 MHz
- 11: KBC clock input is 16 MHz

#### P92EN (Port 92 Enable)

- 1: Enables Port 92 to control GATEA20 and KBRESET.
- 0: Disables Port 92 functions.

#### HGA20 (Hardware GATEA20)

- 1: Selects hardware GATEA20 control logic to control GATE A20 signal.
- 0: Disables hardware GATEA20 control logic function.

#### HKBRST (Hardware Keyboard Reset)

- 1: Selects hardware KB RESET control logic to control KBRESET signal.
- 0: Disables hardware KB RESET control logic function.

When the KBC receives data that follows a "D1" command, the hardware control logic sets or clears GATEA20 according to received data bit 1. Similarly, the hardware control logic sets or clears KBRESET depending on received data bit 0. When the KBC receives an "FE" command, the KBRESET is pulse low for 6 $\mu$ s (Min.) with a 14 $\mu$ s (Min.) delay.

GATEA20 and KBRESET are controlled by either software or hardware logic, and they are mutually exclusive. Then, GATEA20 and KBRESET are merged with Port92 when the P92EN bit is set.



### 13.5.2 Port 92 Control Register

BIT	7	6	5	4	3	2	1	0
NAME	Res. (0)	Res. (0)	Res. (1)	Res. (0)	Res. (0)	Res. (1)	SGA20	PLKBRST

#### SGA20 (Special GATE A20 Control)

1: Drives GATE A20 signal to high.

0: Drives GATE A20 signal to low.

#### PLKBRST (Pull-Low KBRESET)

A logical 1 on this bit causes KBRESET to drive low for 6  $\mu$ S(Min.) with a 14  $\mu$ S(Min.) delay. Before issuing another keyboard-reset command, the bit must be cleared.



## 14. POWER MANAGEMENT EVENT

The PME# (pin 86) signal is connected to the South Bridge and is used to wake up the system from S1 ~ S5 sleeping states.

One control bit and four registers in the W83627DHG are associated with the PME function. The control bit is at Logical Device A, CR[F2h], bit[0] and is for enabling or disabling the PME function. If this bit is set to "0", the W83627DHG won't output any PME signal when any of the wake-up events has occurred and is enabled. The four registers are divided into PME status registers and PME interrupt registers of wake-up events <sup>Note.1</sup>.

- 1) The PME status registers of wake-up event:
  - At Logical Device A, CR[F3h] and CR[F4h]
  - Each wake-up event has its own status
  - The PME status should be cleared by writing a "1" before enabling its corresponding bit in the PME interrupt registers
- 2) The PME interrupt registers of wake-up event:
  - At Logical Device A, CR[F6h] and CR[F7h]
  - Each wake-up event can be enabled / disabled individually to generate a PME# signal

Note.1 PME wake-up events that the W83627DHG supports include:

- Mouse IRQ event
- Keyboard IRQ event
- Printer IRQ event
- Floppy IRQ event
- UART A IRQ event
- UART B IRQ event
- Hardware Monitor IRQ event
- WDTO# event
- RIB (UARTB Ring Indicator) event

### 14.1 Power Control Logic

This chapter describes how the W83627DHG implements its ACPI function via these power control pins: PSIN# (Pin 68), PSOUT# (Pin 67), SUSB# (i.e. SLP\_S3#, Pin 73) and PSON# (Pin 72). The following figure illustrates the relationships.

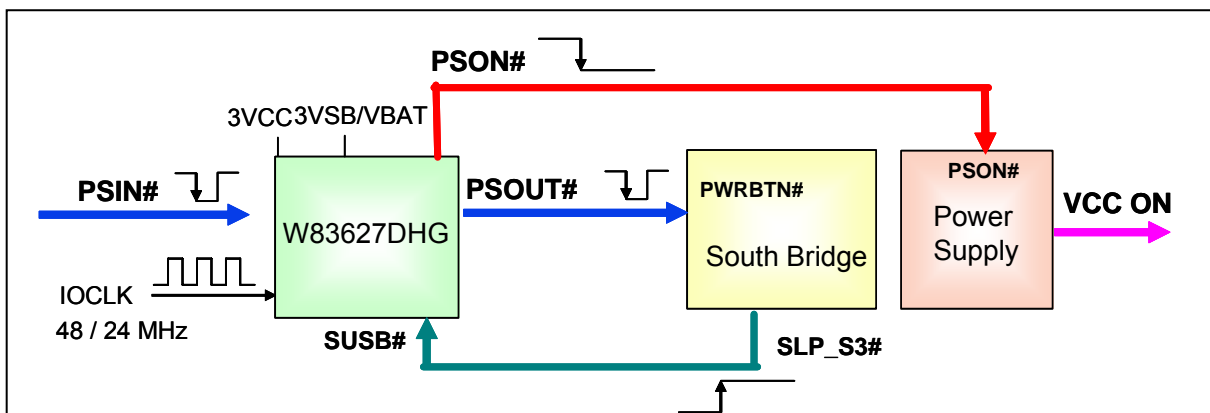

Figure 14.1





**14.1.1 PSIN# Logic**

**14.1.1.1. Normal Operation**

The PSOUT# signal will be asserted low if the PSIN# signal is asserted low. The PSOUT# signal is held low for as long as the PSIN# is held low. The South Bridge controls the SUSB# signal through the PSOUT# signal. The PSIN# is directly connected to the power supply to turn on or off the power.

Figure 14.2 shows the power on and off sequences.

The ACPI state changes from S5 to S0, then to S5

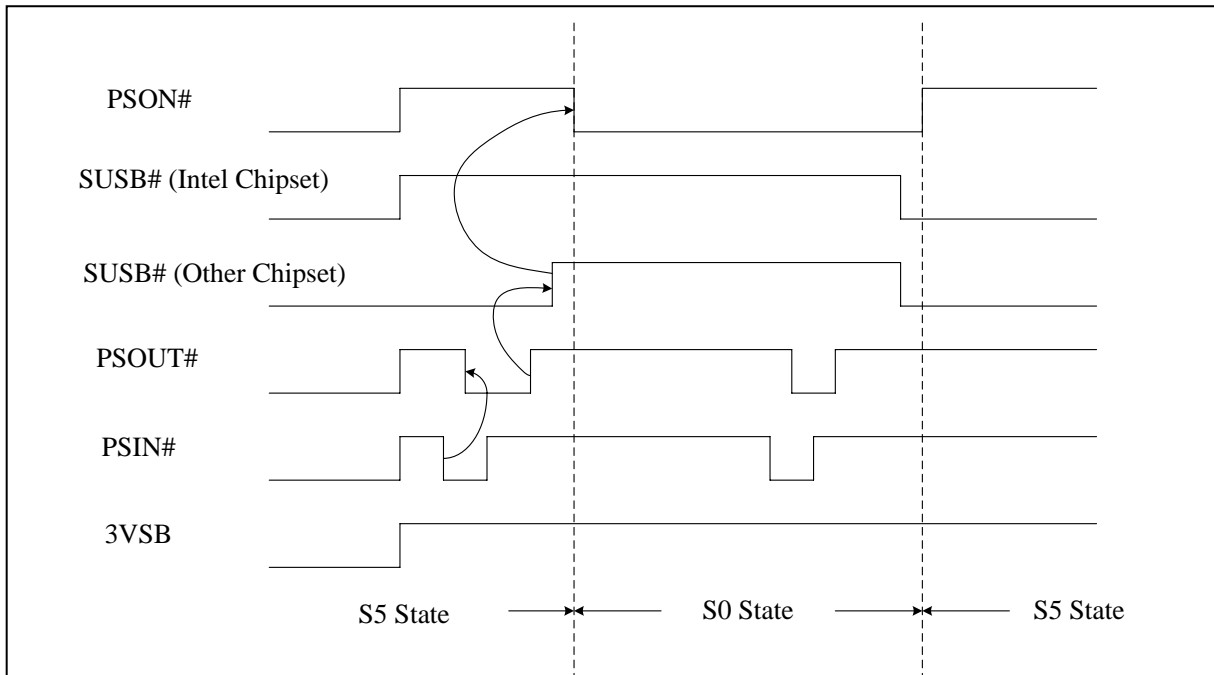

Figure 14.2



**14.1.2 AC Power Failure Resume**

By definition, AC power failure means that the standby power is removed. The power failure resume control logic of the W83627DHG is used to recover the system to a pre-defined state after AC power failure. Two control bits at Logical Device A, CR[E4h], bits[6:5] indicate the pre-defined state. The definition of these two bits is listed in the following table:

LOGICAL DEVICE A, CR[E4H], BITS[6:5]	DEFINITION
00	System always turns off when it returns from AC power failure
01	System always turns on when it returns from AC power failure
10	System turns off / on when it returns from power failure depending on the state before the power failure. (Please see Note 1)
11	User defines the state before the power failure. (The previous state is set at CRE6[4]. Please see Note 2)

Note1. The W83627DHG detects the state before power failure (on or off) through the SUSB# signal and the 3VCC power. The relation is illustrated in the following two figures.

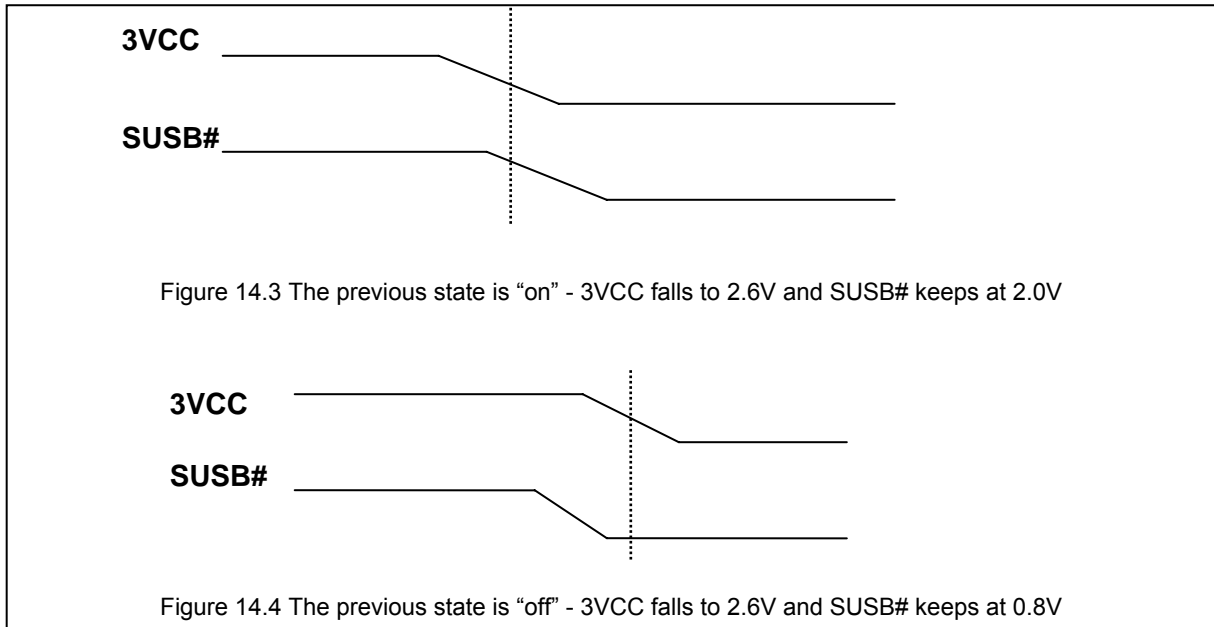

Note 2.

LOGICAL DEVICE A, CR[E6H] BIT [4]	DEFINITION
0	User defines the state to be "on"
1	User defines the state to be "off"

To ensure that VCC does not fall faster than VSB in various ATX Power Supplies, the W83627DHG adds the option of "user define mode" for the pre-defined state before AC power failure. BIOS can set the pre-defined state



to be “On” or “Off”. According to this setting, the system is returned to the pre-defined state after the AC power recovery.

**14.2 Wake Up the System by Keyboard and Mouse**

The W83627DHG generates a low pulse through the PSOUT# pin to wake up the system when it detects a key code pressed or mouse button clicked. The following sections describe how the W83627DHG works.

**14.2.1 Waken up by Keyboard events**

The keyboard Wake-Up function is enabled by setting Logical Device A, CR[E0h], bit 6 to “1”.

There are two keyboard events can be used for the wake-up

- 1) Any key – Set bit 0 at Logical Device A, CR[E0h] to “1” (Default).
- 2) Specific keys (Password) - Set bit 0 at Logical Device A, CR[E0h] to “0”.

Three sets of specific key combinations are stored at Logical Device A. CR[E1h] is an index register to indicate which byte of key code storage (0x00h ~ 0x0Eh, 0x30h ~ 0x3Eh, 0x40h ~ 0x4Eh) is going to be read or written through CR[E2h]. According to IBM 101/102 keyboard specification, a complete key code contains a 1-byte make code and a 2-byte break code. For example, the make code of “0” is 0x45h, and the corresponding break code is 0xF0h, 0x45h.

The approach to implement Keyboard Password Wake-Up Function is to fill key codes into the password storage. Assume that we want to set “012” as the password. The storage should be filled as below. Please note that index 0x09h ~ 0x0Eh must be filled as 0x00h since the password has only three numbers.

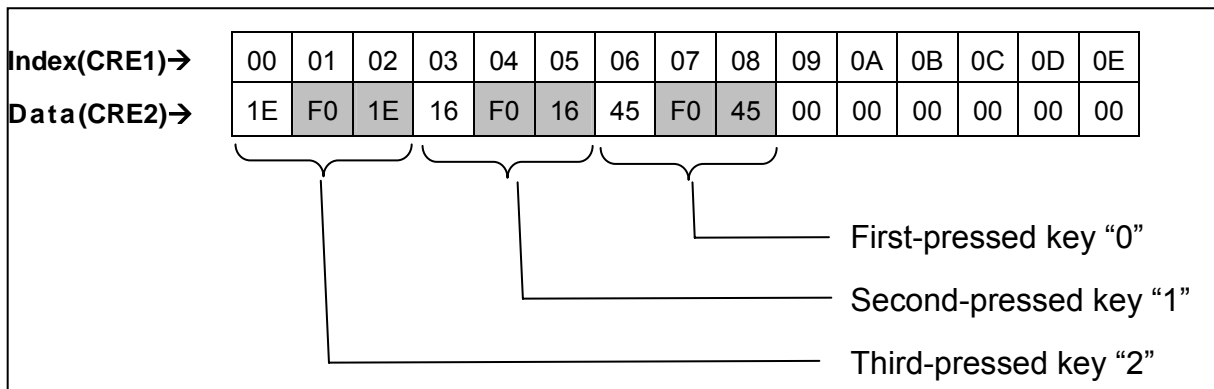

**14.2.2 Waken up by Mouse events**

The mouse Wake-Up function is enabled by setting Logical Device A, CR[E0h], bit 5 to “1”.

The following specific mouse events can be used for the wake-up:

- Any button clicked or any movement
- One click of the left or the right button
- One click of the left button
- One click of the right button
- Two clicks of the left button
- Two clicks of the right button.



Three control bits (ENMDAT\_UP, MSRKEY, MSXKEY) define the combinations of the mouse wake-up events. Please see the following table for the details.

Table 14.1

ENMDAT_UP (LOGICAL DEVICE A, CR[E6H], BIT 7)	MSRKEY (LOGICAL DEVICE A, CR[E0H], BIT 4)	MSXKEY (LOGICAL DEVICE A, CR[E0H], BIT 1)	WAKE-UP EVENT
1	x	1	Any button clicked or any movement.
1	x	0	One click of the left or right button.
0	0	1	One click of the left button.
0	1	1	One click of the right button.
0	0	0	Two clicks of the left button.
0	1	0	Two clicks of the right button.

### 14.3 Resume Reset Logic

The RSMRST# (Pin 75) signal is a reset output and is used as the 3VSB power-on reset signal for the South Bridge.

When the W83627DHG detects the 3VSB voltage rises to "V1", it then starts a delay – "t1" before the rising edge of RSMRST# asserting. If the 3VSB voltage falls below "V2", the RSMRST# de-asserts immediately.

Timing and voltage parameters are shown in Figure 14.5 and Table 14.2.

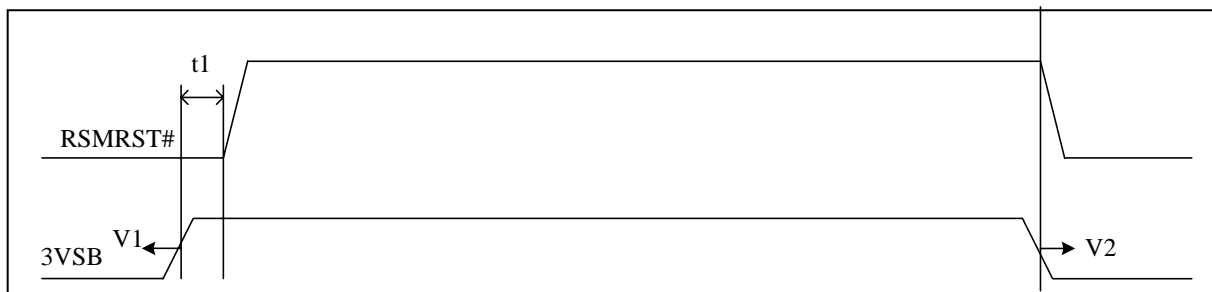

Figure 14.5



SYMBOL	PARAMETER	MIN.	TYP.	MAX.	UNIT	NOTE
V1	3VSB Valid Voltage	2.4	2.6	2.75	V	For both UBC and UBE version
V2	3VSB Ineffective Voltage	2.25	2.4	2.55	V	For both UBC and UBE version
V1	3VSB Valid Voltage	-	-	3.1	V	For UBF version
V2	3VSB Ineffective Voltage	2.4	-	-	V	For UBF version
t1	Valid 3VSB to RSMRST# inactive	100	-	200	mS	

Table 14.2

#### 14.4 PWROK Generation

The PWROK (Pin 71) signal is an output and is used as the 3VCC power-on reset signal.

When the W83627DHG detects the 3VCC voltage rises to “V3”, it then starts a delay – “t2” before the rising edge of PWROK asserting. If the 3VCC voltage falls below “V4”, the PWROK de-asserts immediately.

Timing and voltage parameters are shown in Figure 14.6 and Table 14.3.

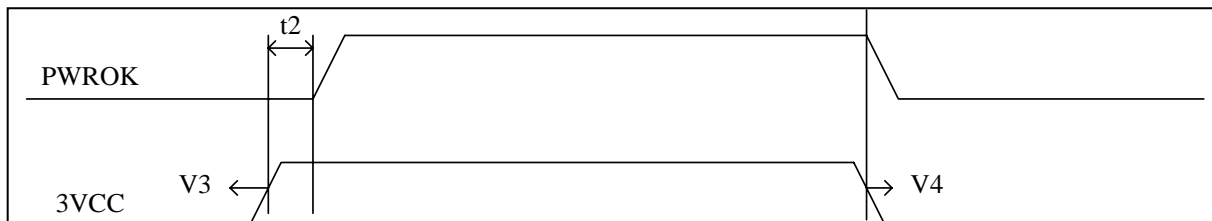

Figure 14.6

SYMBOL	PARAMETER	MIN.	TYP.	MAX.	UNIT	NOTE
V3	3VCC Valid Voltage	2.4	2.6	2.75	V	For both UBC and UBE version
V4	3VCC Ineffective Voltage	2.25	2.4	2.55	V	For both UBC and UBE version
V3	3VCC Valid Voltage	-	-	3.1	V	For UBF version
V4	3VCC Ineffective Voltage	2.4	-	-	V	For UBF version
t2	Valid 3VCC to PWROK active	300	-	500	mS	

Table 14.3

Originally, the t2 timing is between 300 mS to 500 mS, but it can be changed to 200 mS to 300 mS by programming Logical Device A, CR[E6h], bit 3 to “1”. Furthermore, the W83627DHG provides four different extra delay time of PWROK for various demands. The four extra delay time are designed at



Logical Device A, CR[E6h], bits 2~1. The following table shows the definitions of Logical Device A, CR[E6h] bits 3 ~1.

LOGICAL DEVICE A, CR[E6H] BIT	DEFINITION
3	PWROK_DEL (first stage) <b>(VSB)</b> Set the delay time when rising from PWROK_LP to PWROK_ST. 0: 300 ~ 500 mS. 1: 200 ~ 300 mS.
2~1	PWROK_DEL <b>(VSB)</b> Set the delay time when rising from PWROK_ST to PWROK. 00: No delay time.                      01: Delay 32 mS 10: 96 mS                                      11: Delay 250 mS

For example, if Logical Device A, CR[E6h] bit 2 is set to "0" and bits 2~1 are set to "10", the range of  $t_2$  timing is from 396(300 + 96) mS to 596(500 + 96) mS.

\* In UBE and UBF version, PWROK2 generation is the same as PWROK generation.

#### 14.4.1 The Relation among PWROK/PWROK2, ATXPGD and FTPRST# - both for UBE and UBF Version Only

PWROK and PWROK2 signals as well as ATXPGD and FTPRST# input signals are interrelated.

Once the FTPRST# signal changes from high to low then to high, the PWROK and PWROK2 signals will have the same transition after 28mS ~ 39mS delay. The relation and parameter are illustrated in the following figure and table.

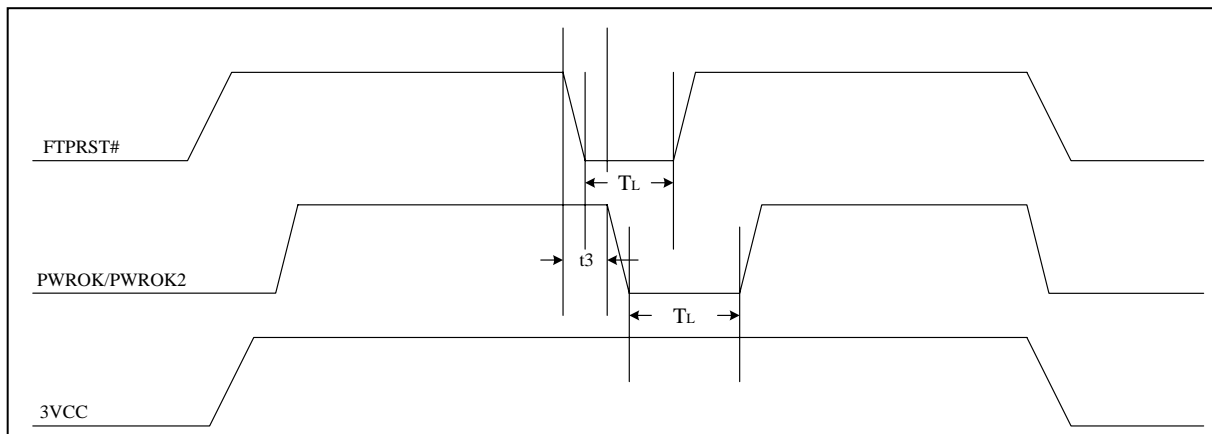

Figure 14.7



Table 14.4

SYMBOL	PARAMETER	MIN	MAX	UNIT
t3	FTPRST# active to PWROK active	28	39	mS

- Note.**
1. The values above are the worst-case results of R&D simulation
  2. The length of  $T_L$  level is based on the length of the low level of FTPRST#

Additionally, the ATXPGD signal, too, is used to control the generation of PWROK and PWROK2. In Figure 14.8, the 3VCC voltage rises to "V3", and then starts a delay – "t2" for PWROK and PWROK2 generation. However, ATXPGD is still inactive after t2; therefore the delay time before the rising edge of PWROK and PWROK2 are t2 plus Td. The length of Td is based on when the ATXPGD signal is active. Once 3VCC falls below "V4" or the ATXPGD signal is inactive, PWROK and PWROK2 de-assert immediately.

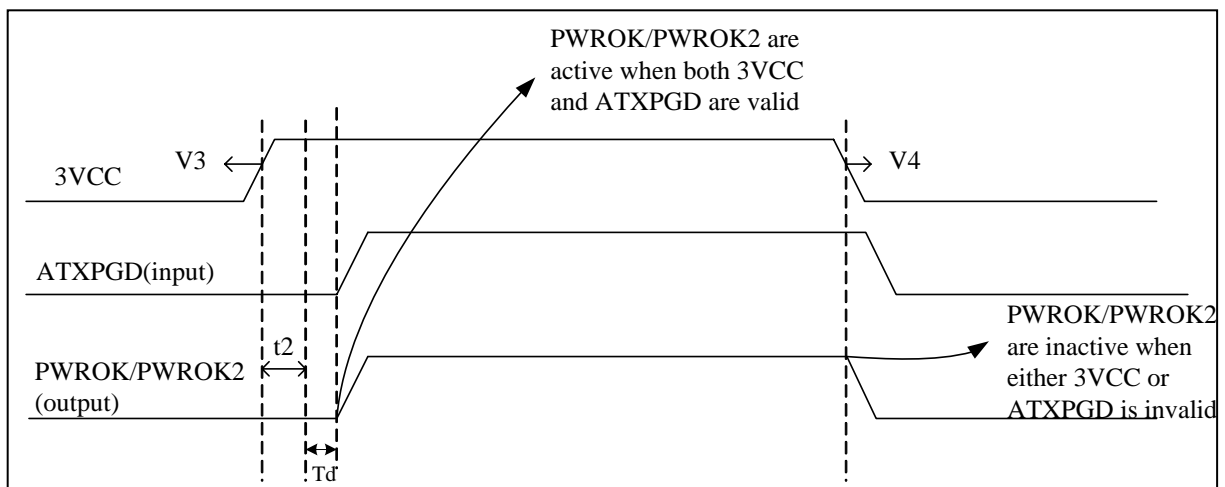

Figure 14.8

In Figure 14.9, the 3VCC voltage rises to "V3", and the ATXPGD is active during t2, so PWROK and PWROK2 assert after t2. The timing of t2 starts when 3VCC voltage rises to "V3". No matter the ATXPGD signal activation is during or after t2, PWROK and PWROK2 assert or de-assert according to the 3VCC voltage and the ATXPGD signal.

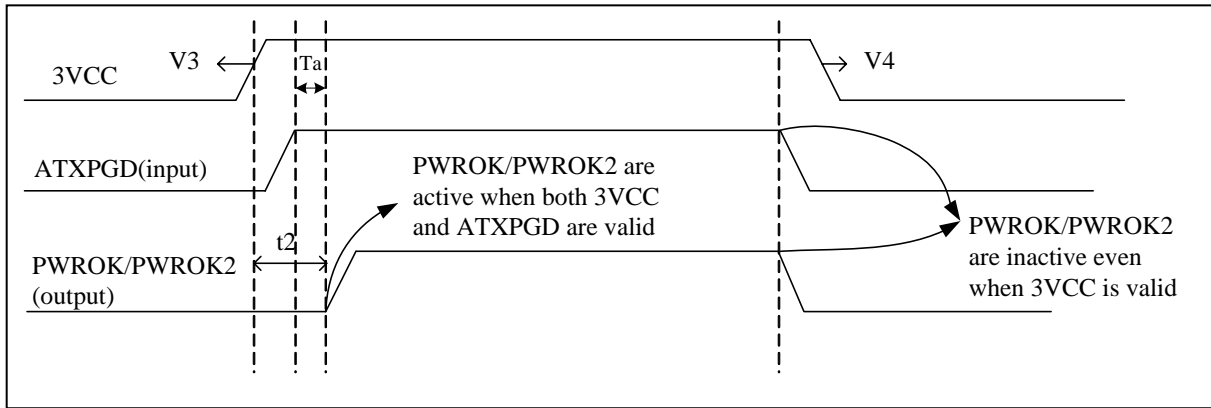

Figure 14.9

Timing and voltage parameters are shown in the following table.

SYMBOL	PARAMETER	MIN.	TYP.	MAX.	UNIT	NOTE
<b>V3</b>	3VCC Valid Voltage	2.4	2.6	2.75	V	For both UBC and UBE version
<b>V4</b>	3VCC Ineffective Voltage	2.25	2.4	2.55	V	For both UBC and UBE version
<b>V3</b>	3VCC Valid Voltage	-	-	3.1	V	For UBF version
<b>V4</b>	3VCC Ineffective Voltage	2.4	-	-	V	For UBF version
<b>t2</b>	Starting from valid 3VCC	300	-	500	mS	





**15. SERIALIZED IRQ**

The W83627DHG supports a serialized IRQ scheme. This allows a signal line to be used to report the parallel interrupt requests. Since more than one device may need to share the signal serial SERIRQ signal, an open drain signal scheme is employed. The clock source is the PCI clock. The serialized interrupt is transferred on the SERIRQ signal, one cycle consisting of three frames types: the Start Frame, the IRQ/Data Frame, and the Stop Frame.

**15.1 Start Frame**

There are two modes of operation for the SERIRQ Start Frame: Quiet mode and Continuous mode.

In the Quiet mode, the W83627DHG drives the SERIRQ signal active low for one clock, and then tri-states it. This brings all the state machines of the W83627DHG from idle to active states. The host controller (the South Bridge) then takes over driving SERIRQ signal low in the next clock and continues driving the SERIRQ low for programmable 3 to 7 clock periods. This makes the total number of clocks low 4 to 8 clock periods. After these clocks, the host controller drives the SERIRQ high for one clock and then tri-states it.

In the Continuous mode, the START Frame can only be initiated by the host controller to update the information of the IRQ/Data Frame. The host controller drives the SERIRQ signal low for 4 to 8 clock periods. Upon a reset, the SERIRQ signal is defaulted to the Continuous mode for the host controller to initiate the first Start Frame.

Please see the diagram below for more details.

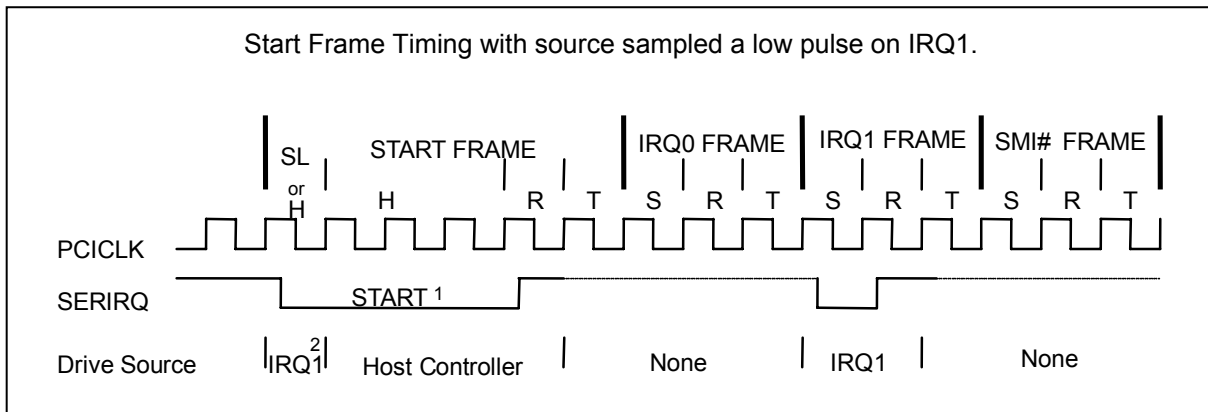

H=Host Control      SL=Slave Control      R=Recovery      T=Turn-around      S=Sample

Note:

1. The Start Frame pulse can be 4-8 clocks wide.
2. The first clock of Start Frame is driven low by the W83627DHG because IRQ1 of the W83627DHG needs an interrupt request. Then the host takes over and continues to pull the SERIRQ low.



## 15.2 IRQ/Data Frame

Once the Start Frame has been initiated, the W83627DHG must start counting frames based on the rising edge of the start pulse. Each IRQ/Data Frame has three clocks: the Sample phase, the Recovery phase, and the Turn-around phase.

During the Sample phase, the W83627DHG drives SERIRQ low if the corresponding IRQ is active. If the corresponding IRQ is inactive, then SERIRQ must be left tri-stated. During the Recovery phase, the W83627DHG device drives the SERIRQ high. During the Turn-around phase, the W83627DHG device leaves the SERIRQ tri-stated. The W83627DHG starts to drive the SERIRQ line from the beginning of "IRQ0 FRAME" based on the rising edge of PCICLK.

The IRQ/Data Frame has a specific numeral order, as shown in Table 15.1.

Table 15.1 SERIRQ Sampling Periods

SERIRQ SAMPLING PERIODS			
IRQ/DATA FRAME	SIGNAL SAMPLED	# OF CLOCKS PAST START	EMPLOYED BY
1	IRQ0	2	-
2	IRQ1	5	Keyboard
3	SMI#	8	-
4	IRQ3	11	UART B
5	IRQ4	14	UART A
6	IRQ5	17	-
7	IRQ6	20	FDC
8	IRQ7	23	LPT
9	IRQ8	26	-
10	IRQ9	29	-
11	IRQ10	32	-
12	IRQ11	35	-
13	IRQ12	38	Mouse
14	IRQ13	41	-
15	IRQ14	44	-
16	IRQ15	47	-
17	IOCHCK#	50	-
18	INTA#	53	-
19	INTB#	56	-
20	INTC#	59	-
21	INTD#	62	-
32:22	Unassigned	95	-



### 15.3 Stop Frame

After all IRQ/Data Frames have completed, the host controller will terminate SERIRQ with a Stop frame. Only the host controller can initiate the Stop Frame by driving SERIRQ low for 2 or 3 clocks. If the Stop Frame is low for 2 clocks, the Sample mode of next SERIRQ cycle's Sample mode is the Quiet mode. If the Stop Frame is low for 3 clocks, the Sample mode of next SERIRQ cycle is the Continuous mode.

Please see the diagram below for more details.

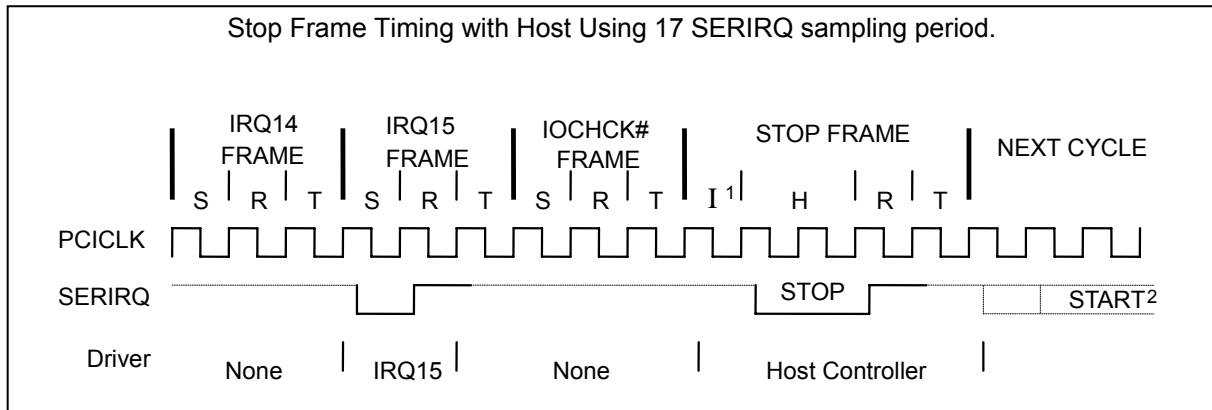

H=Host Control      R=Recovery      T=Turn-around      S=Sample      I= Idle.

Note:

1. There may be none, one or more Idle states during the Stop Frame.
2. The Start Frame pulse of next SERIRQ cycle may or may not start immediately after the turn-around clock of the Stop Frame.



## **16. WATCHDOG TIMER**

The WDTO# pin is a multi-function pin with GP50 functions and is configured to the WDTO# function, if Configuration Register CR[2Dh], bit 0 is set to zero.

The Watchdog Timer of the W83627DHG consists of an 8-bit programmable time-out counter and a control and status register. The time-out counter ranges from 1 to 255 minutes in the minute mode, or 1 to 255 seconds in the second mode. The units of Watchdog Timer counter are selected at Logical Device 8, CR[F5h], bit[3]. The time-out value is set at Logical Device 8, CR[F6h]. Writing zero disables the Watchdog Timer function. Writing any non-zero value to this register causes the counter to load this value into the Watchdog Timer counter and start counting down.

The W83627DHG outputs a low signal to the WDTO# pin (pin 77) when a time-out event occurs. In other words, when the value is counted down to zero, the timer stops, and the W83627DHG sets the WDTO# status bit in Logical Device 8, CR[F7h], bit[4], outputting a low signal to the WDTO# pin (pin 77). Writing a zero will clear the status bit and the WDTO# pin returns to high. Writing a zero will clear the status bit. This bit will also be cleared if LRESET# or PWROK# signal is asserted.

Additionally, GP40 (pin 85), GP42 (pin 83), GP44 (pin 81) and GP46 (pin 79) provides an alternative WDTO# function. This function can be configured by the relative GPIO control register.

Please note that the output type of WDTO# (pin 77) and GP42 (pin 83) is push-pull and that of GP40 (pin 85), GP44 (pin 81) and GP46 (pin 79) is open-drain.



## 17. GENERAL PURPOSE I/O

The W83627DHG provides 40 input/output ports that can be individually configured to perform a simple basic I/O function or alternative, pre-defined function. GPIO port 6 is configured through control registers in Logical Device 7, and GPIO ports 2 ~ 5 in Logical Device 9. Users can configure each individual port to be an input or output port by programming respective bit in selection register (0 = output, 1 = input). Invert port value by setting inversion register (0 = non -inverse, 1 = inverse). Port value is read / written through data register.

In addition, only GP30, GP31 and GP35 are designed to be able to assert PSOUT# or PME# signal to wake up the system if any of them has any transitions. There are about 16mS debounced circuit inside these 3 GPIOs and it can be disabled by programming respective bit (LD9, CR[FEh] bit 4~6). Users can set what kind of event type, level or edge, and polarity, rising or falling, to perform the wake-up function. The following table gives a more detailed register map on GP30, GP31 and GP35.

	<b>EVENTROUTE I (PSOUT#)</b> 0: DISABLE 1: ENABLE	<b>EVENTROUTE II (PME#)</b> 0: DISABLE 1: ENABLE	<b>EVENT DEBOUNCED</b> 0 : ENABLE 1 : DISABLE	<b>EVENT TYPE</b> 0 : EDGE 1: LEVEL	<b>EVENT POLARITY</b> 0 : RISING 1 : FALLING	<b>EVENT STATUS</b>
<b>GP30</b>	LDA, CR[FEh] bit4	LDA, CR[FEh] bit0	LD9, CR[FEh] bit4	LD9, CR[FEh] bit0	LD9, CR[F2h] bit0	LD9, CR[E7h] bit0
<b>GP31</b>	LDA, CR[FEh] bit5	LDA, CR[FEh] bit1	LD9, CR[FEh] bit5	LD9, CR[FEh] bit1	LD9, CR[F2h] bit1	LD9, CR[E7h] bit1
<b>GP35</b>	LDA, CR[FEh] bit6	LDA, CR[FEh] bit2	LD9, CR[FEh] bit6	LD9, CR[FEh] bit2	LD9, CR[F2h] bit5	LD9, CR[E7h] bit5



## **18. VID INPUTS AND OUTPUTS**

The W83627DHG provides eight pins for VID input or output function. The default function is VID input. These pins can be configured to VID output function by setting Logical Device B, CR[F0h], bit 7 to 0. The configuration is applied to the 8 pins as a group. None of them can be individually set to input or output.

### **18.1 VID Input Detection**

The W83627DHG supports Intel VRM 9/10/11 and AMD VRM VID detections. H/W strapping and S/W programming can set the following three input levels. a) and b) can be set by H/W strapping or S/W programming, while c) can only be set by S/W programming.

a) TTL ( $V_{ih} = 2\text{ V}$ ;  $V_{il} = 0.8\text{ V}$ ) –

- 1) Add a pulled-down resistor at Pin 77(EN\_GTL), or
- 2) Set Configuration Register CR[2Ch], bit 3 to “0”;

b) GTL ( $V_{ih} = 0.6\text{ V}$ ;  $V_{il} = 0.4\text{ V}$ ) – (Default)

- 1) No extra pulled-up resistor needed, or
- 2) Set Configuration Register CR[2Ch], bit 3 to “1”;

c) AMD VRM ( $V_{ih} = 1.4\text{ V}$ ;  $V_{il} = 0.8\text{ V}$ ) –

Set Configuration Register CR[2Ch], bit 3 to “1” and Logical Device B, CR[F0h], bit 6 to “1”.

The input data can be read in the data register at Logical Device B, CR[F1h], bit 7 ~ 0. It is a read/write register where bit 7~0 corresponds to VID pin 7~0. Please note that in the input mode, writes to this register have no effect.

### **18.2 VID Output Control**

The output type of the eight VID pins is push-pull, and they drive to 3VCC (3.3V) when configured to the output mode. The output data can be set in the data register (Logical Device B, CR[F1h], bit 7 ~ 0). The written data can be read if Configuration Register CR[2Ch], bit 3 is set to “0”.

**19. PCI RESET BUFFERS**

The W83627DHG has five copies of LRESET# output buffers. LRESET# is LPC Interface Reset, to which PCI Reset is connected. The five copies of LRESET# in the W83627DHG are designated RSTOUT0#, RSTOUT1#, RSTOUT2#, RSTOUT3# and RSTOUT4#. All of them are powered by a 3VSB power.

RSTOUT0# is an open-drain output buffer of LRESET#. This signal needs an external pulled-up resistor of 3.3V or 5V.

RSTOUT1#, RSTOUT2#, RSTOUT3# and RSTOUT4# are push-pull output buffers of LRESET#. Each of them outputs 3.3V, voltage and the state is low when the 3VSB power is the only power source.



## 20. CONFIGURATION REGISTER

### 20.1 Chip (Global) Control Register

#### CR 02h. (Software Reset; Write Only)

BIT	READ / WRITE	DESCRIPTION
7~1	Reserved.	
0	Write "1" Only	Software RESET.

#### CR 07h. (Logical Device; Default 00h)

BIT	READ / WRITE	DESCRIPTION
7~0	R / W	Logical Device Number.

#### CR 20h. (Chip ID, High Byte; Read Only)

BIT	READ / WRITE	DESCRIPTION
7~0	Read Only	Chip ID number = A0h (high byte).

#### CR 21h. (Chip ID, Low Byte; Read Only)

BIT	READ / WRITE	DESCRIPTION
7~0	Read Only	Chip ID number = 2Xh (low byte). X is the IC version

#### CR 22h. (Device Power Down; Default FFh)

BIT	READ / WRITE	DESCRIPTION
7	Reserved.	
6	R / W	HM Power Down. 0: Powered down. 1: Not powered down.
5	R / W	UARTB Power Down. 0: Powered down. 1: Not powered down.
4	R / W	UARTA Power Down. 0: Powered down. 1: Not powered down.
3	R / W	PRT Power Down. 0: Powered down. 1: Not powered down.
2~1	Reserved.	
0	R / W	FDC Power Down. 0: Powered down. 1: Not powered down.

#### CR 23h. (IPD; Default 00h)

BIT	READ / WRITE	DESCRIPTION
7~1	Reserved.	
0	R / W	IPD (Immediate Power Down). When set to 1, the whole chip is put into power-down mode immediately.





CR 24h. (Global Option; Default 0100\_0ss0b)

s: value by strapping

BIT	READ / WRITE	DESCRIPTION
7	R / W	Select output type of CPUFANOUT1 =0 CPUFANOUT1 is Push-pull. (Default) =1 CPUFANOUT1 is Open-drain.
6	R / W	CLKSEL => Input clock rate selection = 0 The clock input on pin 18 is 24 MHz. = 1 The clock input on pin 18 is 48 MHz. (Default)
5	R / W	Select output type of AUXFANOUT =0 AUXFANOUT is Push-pull. (Default) =1 AUXFANOUT is Open-drain.
4	R / W	Select output type of SYSFANOUT =0 SYSFANOUT is Open-drain. (Default) =1 SYSFANOUT is Push-pull.
3	R / W	Select output type of CPUFANOUT0 =0 CPUFANOUT0 is Open-drain. (Default) =1 CPUFANOUT0 is Push-pull.
2	Read Only	ENKBC => Enable keyboard controller = 0 KBC is disabled after hardware reset. = 1 KBC is enabled after hardware reset. This bit is read-only, and it is set or reset by a power-on strapping pin (Pin 54, SOUTA).
1	R / W	ENROM => Enable Serial Peripheral Interface = 0 ROM is disabled after hardware reset. = 1 ROM is enabled after hardware reset. This bit is set or reset by a power-on strapping pin (Pin 52, DTRA#). <b>Note 1</b>
0	Reserved.	

**Note1:**

Disable Serial Peripheral Interface	Enable Serial Peripheral Interface
Pin 2 → GP23	Pin 2 → SCK
Pin 19 → GP22	Pin 19 → SCE
Pin 58 → AUXFANIN1	Pin 58 → SI
Pin 118 → BEEP	Pin 118 → SO

**CR 25h. (Interface Tri-state Enable; Default 00h)**

BIT	READ / WRITE	DESCRIPTION
7~6	Reserved.	
5	R / W	UARTBTRI
4	R / W	UARTATRI
3	R / W	PRTTRI
2~1	Reserved.	
0	R / W	FDCTRI.

**CR 26h. (Global Option; Default 0s000000b)** s: value by strapping

BIT	READ / WRITE	DESCRIPTION
7	Reserved.	
6	R / W	HEFRAS => = 0 Write 87h to location 2E twice. = 1 Write 87h to location 4E twice. The corresponding power-on strapping pin is RTSA# (Pin 51).
5	R / W	LOCKREG => = 0 Enable R/W configuration registers. = 1 Disable R/W configuration registers.
4	Reserved.	
3	R / W	DSFDLGRQ => = 0 Enable FDC legacy mode for IRQ and DRQ selection. Then DO register (base address + 2) bit 3 is effective when selecting IRQ. = 1 Disable FDC legacy mode for IRQ and DRQ selection. Then DO register (base address + 2) bit 3 is not effective when selecting IRQ.
2	R / W	DSPRLGRQ => = 0 Enable PRT legacy mode for IRQ and DRQ selection. Then DCR register (base address + 2) bit 4 is effective when selecting IRQ. = 1 Disable PRT legacy mode for IRQ and DRQ selection. Then DCR register (base address + 2) bit 4 is not effective when selecting IRQ.
1	R / W	DSUALGRQ => = 0 Enable UART A legacy mode for IRQ selection. Then HCR register (base address + 4) bit 3 is effective when selecting IRQ. = 1 Disable UART A legacy mode for IRQ selection. Then HCR register (base address + 4) bit 3 is not effective when selecting IRQ.
0	R / W	DSUBLGRQ => = 0 Enable UART B legacy mode for IRQ selection. Then HCR register (base address + 4) bit 3 is effective when selecting IRQ. = 1 Disable UART B legacy mode for IRQ selection. Then HCR register (base address + 4) bit 3 is not effective when selecting IRQ.

**CR 27h. (Reserved)****CR 28h. (Global Option; Default 50h)**

BIT	READ / WRITE	DESCRIPTION
7		Reserved.
6~5	R / W	Flash ROM size select = 00 1M = 01 2M = 10 4M (Default) = 11 8M
4	R / W	Select to enable/disable decoding of BIOS ROM range 000E xxxxh. = 0 Enable decoding of BIOS ROM range at 000E xxxxh. = 1 Disable decoding of BIOS ROM range at 000E xxxxh.
3	R / W	Select to enable/disable decoding of BIOS ROM range FFE xxxxx. = 0 Enable decoding of BIOS ROM range at FFE xxxxx. = 1 Disable decoding of BIOS ROM range at FFE xxxxx.
2~0	R / W	PRTMODS2 ~ 0 => = 0xx Parallel Port Mode. = 1xx Reserved.

**CR 29h. (Multi-function Pin Selection; Default 00h)**

BIT	READ / WRITE	DESCRIPTION									
7		Reserved.									
6	R / W	Pin 5 function select = 0 OVT# = 1 SMI#									
5~4		Reserved.									
3	R / W	Pins 49 ~ 54, 56 ~ 57 function select = 0 Pins 49 ~ 54, 56 ~ 57 → UART A = 1 Pins 49 ~ 54, 56 ~ 57 → GPIO6									
2~1	R / W	Pin 119 ~ 120 function select									
		<table border="1"> <thead> <tr> <th>Bit-2</th> <th>Bit-1</th> <th>Pin 119 ~ 120 function</th> </tr> </thead> <tbody> <tr> <td>0</td> <td>0</td> <td>Pin 119 ~ 120 → CPUFANIN1, CPUFANOUT1 (Default)</td> </tr> <tr> <td>0</td> <td>1</td> <td>Pin 119 ~ 120 → GP21, GP20</td> </tr> </tbody> </table>	Bit-2	Bit-1	Pin 119 ~ 120 function	0	0	Pin 119 ~ 120 → CPUFANIN1, CPUFANOUT1 (Default)	0	1	Pin 119 ~ 120 → GP21, GP20
		Bit-2	Bit-1	Pin 119 ~ 120 function							
0	0	Pin 119 ~ 120 → CPUFANIN1, CPUFANOUT1 (Default)									
0	1	Pin 119 ~ 120 → GP21, GP20									
0		Reserved.									



## CR 2Ah. (SPI Configuration; Default 00h) (VSB Power)

BIT	READ / WRITE	DESCRIPTION
7~6	R / W	Serial Peripheral Interface Configuration bit. <b>(VSB) – These two bits are for UBE and UBF version only</b> = 00 Normal read. SPI clock is 16MHz. = 01 Normal read. SPI clock is 33MHz. = 10 Normal read. SPI clock is 22MHz. = 11 Reserved. <b>Note: These two bits are ignored when CR24, bit 1 is “0” (SPI function is disabled).</b>
5~4	R / W	Serial Peripheral Interface configuration bit. <b>(VBAT)</b> = 00 Normal read. The clock rate is based on the setting of CR[2Ah], bits[7:6] = 01 Reserved = 10 Reserved = 11 Fast read with one dummy byte. The clock rate is 33MHz. If set to “11”, CR[2Ah], bits[7:6] must be 0. <b>Note: These two bits are ignored when CR24, bit 1 is “0”. (SPI function is disabled)</b>
3	R/W	SDA_filter_EN: 0: Enable SDA input to a filter 1: Disable SDA input to a filter
2	R / W	SCL_filter_EN: 0: Enable SCL input to a filter 1: Disable SCL input to a filter
1	R / W	Pin 89, Pin 90 function select (I <sup>2</sup> C interface) = 0 {Pin 89, Pin 90} → set by CR2C bits[6:5]. = 1 {Pin 89, Pin 90} → SDA, SCL.
0	R / W	KB, MS pin function select = 0 KB, MS function. = 1 GPIO function.(GP24, GP25, GP26 and GP27)

\* Normal Read: Read 1-byte data.

Fast Read: Read 4-byte data.

## CR 2Bh. (Reserved)



## CR 2Ch. (Multi-function Pin Selection; Default E2h) (VSB Power)

BIT	READ / WRITE	DESCRIPTION															
7	R / W	Pin 88 Select = 0 GP34 = 1 RSTOUT4# (Default)															
6	R / W	Pin 89 Select = 0 GP33 = 1 RSTOUT3# (Default) <b>Note: This bit is ignored when CR2A, bit 1 is High.</b>															
5	R / W	Pin 90 Select = 0 GP32 = 1 RSTOUT2# (Default) <b>Note: This bit is ignored when CR2A, bit 1 is High.</b>															
4	Read Only	EN_ACPI status bit = 0 Particular ACPI functions are disabled. = 1 Particular ACPI functions are enabled. The bit is strapped by Pin 70 (GP55). While particular ACPI functions are enabled (EN_ACPI = 1), GPIO3 pins (pins 64, 69, 87, 91 and 92) are disabled and the particular ACPI functions are activated (SUSC#, FTPRST#, ATXPGD, VSBGATE# and PWROK2) * This bit is available both for UBE and UBF version															
3	R / W	EN_GTL Configure bit = 0 VID input voltage is TTL. = 1 VID input voltage is GTL. The bit is strapped by Pin 77 (GP50).--- Internal Pull high to 3VSB.															
2	R / W	EN_PWRDN. ( <b>VBAT</b> ) = 0 Thermal shutdown function is disabled. = 1 Enable thermal shutdown function.															
1~0	R / W	<p>Pins 78 ~ 85 function select</p> <table border="1"> <thead> <tr> <th>Bit-1</th> <th>Bit-0</th> <th>Pins 78 ~ 85 function</th> </tr> </thead> <tbody> <tr> <td>0</td> <td>0</td> <td>Pin 82 → Reserved (tri-state) Pin 83 → Reserved (always low) Others → GPIO4</td> </tr> <tr> <td>0</td> <td>1</td> <td>Pin 82 → IRRX Pin 83 → IRTX Others → GPIO4</td> </tr> <tr> <td>1</td> <td>0</td> <td>Pins 78 ~ 85 → GPIO4</td> </tr> <tr> <td>1</td> <td>1</td> <td>Pins 78 ~ 85 → UART B</td> </tr> </tbody> </table>	Bit-1	Bit-0	Pins 78 ~ 85 function	0	0	Pin 82 → Reserved (tri-state) Pin 83 → Reserved (always low) Others → GPIO4	0	1	Pin 82 → IRRX Pin 83 → IRTX Others → GPIO4	1	0	Pins 78 ~ 85 → GPIO4	1	1	Pins 78 ~ 85 → UART B
Bit-1	Bit-0	Pins 78 ~ 85 function															
0	0	Pin 82 → Reserved (tri-state) Pin 83 → Reserved (always low) Others → GPIO4															
0	1	Pin 82 → IRRX Pin 83 → IRTX Others → GPIO4															
1	0	Pins 78 ~ 85 → GPIO4															
1	1	Pins 78 ~ 85 → UART B															

**CR 2Dh. (Multi-function Pin Selection; default 21h) (VSB Power)**

BIT	READ / WRITE	DESCRIPTION
7	R / W	Pin 67 Select (reset by RSMRST#) = 0 PSOUT# = 1 GPIO57
6	R / W	Pin 68 Select (reset by RSMRST#) = 0 PSIN# = 1 GPIO56
5	R / W	Pin 70 Select (reset by RSMRST#) = 0 SUSLED = 1 GPIO55
4	R / W	Pin 71 Select (reset by RSMRST#) = 0 PWROK = 1 GPIO54
3	R / W	Pin 72 Select (reset by RSMRST#) = 0 PSON# = 1 GPIO53
2	R / W	Pin 73 Select (reset by RSMRST#) = 0 SUSB# = 1 GPIO52
1	R / W	Pin 75 Select (reset by RSMRST#) = 0 RSMRST# = 1 GPIO51
0	R / W	Pin 77 Select (reset by RSMRST#) = 0 WDTO# = 1 GPIO50

**CR 2Eh. (Default 00h)**

BIT	READ / WRITE	DESCRIPTION
7~0	R / W	Test Mode Bits: Reserved for Winbond.

**CR 2Fh. (Default 00h)**

BIT	READ / WRITE	DESCRIPTION
7~0	R / W	Test Mode Bits: Reserved for Winbond.



## 20.2 Logical Device 0 (FDC)

### CR 30h. (Default 01h)

BIT	READ / WRITE	DESCRIPTION
7~1	Reserved.	
0	R / W	0: Logical device is inactive. 1: Activate the logical device.

### CR 60h, 61h. (Default 03h,F0h)

BIT	READ / WRITE	DESCRIPTION
7~0	R / W	These two registers select FDC I/O base address <100h: FF8h> on 8 bytes boundary.

### CR 70h. (Default 06h)

BIT	READ / WRITE	DESCRIPTION
7~4	Reserved.	
3~0	R / W	These bits select IRQ resource for FDC.

### CR 74h. (Default 02h)

BIT	READ / WRITE	DESCRIPTION
7~3	Reserved.	
2~0	R / W	These bits select DRQ resource for FDC. 000: DMA0. 001: DMA1. 010: DMA2. 011: DMA3. 1xx: No DMA active.

### CR F0h. (Default 8Eh)

BIT	READ / WRITE	DESCRIPTION
7	Reserved.	
6	R / W	This bit determines the polarity of all FDD interface signals. 0: FDD interface signals are active low. 1: FDD interface signals are active high.
5	R / W	When this bit is logic 0, indicates a second drive is installed and is reflected in status register A. (PS2 mode only)
4	R / W	Swap Drive 0, 1 Mode => 0: No Swap. 1: Drive and Motor select 0 and 1 are swapped.
3~2	R / W	Interface Mode. 00: Model 30. 01: PS/2. 10: Reserved. 11: AT Mode



Continued

BIT	READ / WRITE	DESCRIPTION
1	R / W	FDC DMA Mode. 0: Burst Mode is enabled 1: Non-Burst Mode.
0	R / W	Floppy Mode. 0: Normal Floppy Mode. 1: Enhanced 3-mode FDD.

**CR F1h. (Default 00h)**

BIT	READ / WRITE	DESCRIPTION
7~6	R / W	Boot Floppy. 00: FDD A. 01: Reserved. 10: Reserved. 11: Reserved.
5~4	R / W	Media ID1, Media ID0. These bits will be reflected on FDC's Tape Drive Register bit 7, 6.
3~2	R / W	Density Select. 00: Normal. 01: Normal. 10: 1 (Forced to logic 1). 11: 0 (Forced to logic 0).
1	R / W	DISFDDWR => 0: Enable FDD write. 1: Disable FDD write (forces pins WE, WD to stay high).
0	R / W	SWWP => 0: Normal, use WP to determine whether the FDD is write protected or not. 1: FDD is always write-protected.

**CR F2h. (Default FFh)**

BIT	READ / WRITE	DESCRIPTION
7~2	Reserved.	
1~0	R / W	FDD A Drive Type.

**CR F4h. (Default 00h)**

BIT	READ / WRITE	DESCRIPTION
7	Reserved.	
6	R / W	0: Enable FDC Pre-compensation. 1: Disable FDC Pre-compensation.
5	Reserved.	
4~3	R / W	Data Rate Table selection (Refer to TABLE A). 00: Select regular drives and 2.88 format. 01: 3-mode drive. 10: 2 Meg Tape. 11: Reserved.
2	Reserved.	
1~0	R / W	Drive Type selection (Refer to TABLE B).





## CR F5h. (Default 00h)

BIT	READ / WRITE	DESCRIPTION
7~0	R / W	Same as FDD0 of CR F5h.

TABLE A

DRIVE RATE TABLE SELECT		DATA RATE		SELECTED DATA RATE		SELDEN
DRTS1	DRTS0	DRATE1	DRATE0	MFM	FM	
0	0	1	1	1Meg	---	1
		0	0	500K	250K	1
		0	1	300K	150K	0
		1	0	250K	125K	0
0	1	1	1	1Meg	---	1
		0	0	500K	250K	1
		0	1	500K	250K	0
		1	0	250K	125K	0
1	0	1	1	1Meg	---	1
		0	0	500K	250K	1
		0	1	2Meg	---	0
		1	0	250K	125K	0

TABLE B

DTYPE0	DTYPE1	DRV DEN0 (pin 2)	DRIVE TYPE
0	0	SEL DEN	4/2/1 MB 3.5" 2/1 MB 5.25" 2/1.6/1 MB 3.5" (3-MODE)
0	1	DRATE1	
1	0	$\overline{\text{SEL DEN}}$	
1	1	DRATE0	



### 20.3 Logical Device 1 (Parallel Port)

#### CR 30h. (Default 01h)

BIT	READ / WRITE	DESCRIPTION
7~1	Reserved.	
0	R / W	0: Logical device is inactive. 1: Activate the logical device.

#### CR 60h, 61h. (Default 03h, 78h)

BIT	READ / WRITE	DESCRIPTION
7~0	R / W	These two registers select PRT I/O base address. <100h: FFCh> on 4-byte boundary (EPP not supported) or <100h: FF8h> on 8-byte boundary (all modes supported, EPP is only available when the base address is on 8-byte boundary).

#### CR 70h. (Default 07h)

BIT	READ / WRITE	DESCRIPTION
7~4	Reserved.	
3~0	R / W	These bits select IRQ resource for PRT.

#### CR 74h. (Default 04h)

BIT	READ / WRITE	DESCRIPTION
7~3	Reserved.	
2~0	R / W	These bits select DRQ resource for PRT. 000: DMA0. 001: DMA1. 010: DMA2. 011: DMA3. 1xx: No DMA active.

#### CR F0h. (Default 3Fh)

BIT	READ / WRITE	DESCRIPTION
7	Reserved.	
6~3	R / W	ECP FIFO Threshold.
2~0	R / W	Parallel Port Mode selection (CR28 bit2 PRTMODS2 = 0). 000: Standard and Bi-direction (SPP) mode. 001: EPP – 1.9 and SPP mode. 010: ECP mode. 011: ECP and EPP – 1.9 mode. 100: Printer Mode. 101: EPP – 1.7 and SPP mode. 110: Reserved. 111: ECP and EPP – 1.7 mode.



## 20.4 Logical Device 2 (UART A)

### CR 30h. (Default 01h)

BIT	READ / WRITE	DESCRIPTION
7~1	Reserved.	
0	R / W	0: Logical device is inactive. 1: Activate the logical device.

### CR 60h, 61h. (Default 03h, F8h)

BIT	READ / WRITE	DESCRIPTION
7~0	R / W	These two registers select Serial Port 1 I/O base address <100h: FF8h> on 8 bytes boundary.

### CR 70h. (Default 04h)

BIT	READ / WRITE	DESCRIPTION
7~4	Reserved.	
3~0	R / W	These bits select IRQ resource for Serial Port 1.

### CR F0h. (Default 00h)

BIT	READ / WRITE	DESCRIPTION
7~2	Reserved.	
1~0	R / W	00: UART A clock source is 1.8462 MHz (24 MHz / 13). 01: UART A clock source is 2 MHz (24 MHz / 12). 00: UART A clock source is 24 MHz (24 MHz / 1). 00: UART A clock source is 14.769 MHz (24 MHz / 1.625).

## 20.5 Logical Device 3 (UART B)

### CR 30h. (Default 01h)

BIT	READ / WRITE	DESCRIPTION
7~1	Reserved.	
0	R / W	0: Logical device is inactive. 1: Activate the logical device.

### CR 60h, 61h. (Default 02h, F8h)

BIT	READ / WRITE	DESCRIPTION
7~0	R / W	These two registers select Serial Port 2 I/O base address <100h: FF8h> on eight-byte boundary.

**CR 70h. (Default 03h)**

BIT	READ / WRITE	DESCRIPTION
7~4	Reserved.	
3~0	R / W	These bits select IRQ resource for Serial Port 2.

**CR F0h. (Default 00h)**

BIT	READ / WRITE	DESCRIPTION
7~4	Reserved.	
3	R / W	0: No reception delay when SIR is changed from TX mode to RX mode. 1: Reception delayed for 4 characters' time (40 bit-time) when SIR is changed from TX mode to RX mode.
2	R / W	0: No transmission delay when SIR is changed from RX mode to TX mode. 1: Transmission delayed for 4 characters' time (40 bit-time) when SIR is changed from RX mode to TX mode.
1~0	R / W	00: UART B clock source is 1.8462 MHz (24 MHz / 13). 01: UART B clock source is 2 MHz (24 MHz / 12). 00: UART B clock source is 24 MHz (24 MHz / 1). 00: UART B clock source is 14.769 MHz (24 MHz / 1.625).

**CR F1h. (Default 00h)**

BIT	READ / WRITE	DESCRIPTION
7	R / W	Reserved.
6	R / W	IRLOCSEL => IR I/O pins' location selection. 0: Through SINB / SOUTB. 1: Through IRRX / IRTX.
5~3	R / W	IRMODE => IR function mode selection. See the table below.
2	R / W	IR half / full duplex function selection. 0: IR function is Full Duplex. 1: IR function is Half Duplex.
1	R / W	0: SOUTB pin of UART B function or IRTX pin of IR function in normal condition. 1: Inverse SOUTB pin of UART B function or IRTX pin of IR function.
0	R / W	0: SINB pin of UART B function or IRRX pin of IR function in normal condition. 1: Inverse SINB pin of UART B function or IRRX pin of IR function.



IR MODE	IR FUNCTION	IRTX	IRRX
00X	Disable	Tri-state	High
010*	IrDA	Active pulse 1.6 $\mu$ S	Demodulation into SINB/IRRX
011*	IrDA	Active pulse 3/16 bit time	Demodulation into SINB/IRRX
100	ASK-IR	Inverting IRTX/SOUTB pin	Routed to SINB/IRRX
101	ASK-IR	Inverting IRTX/SOUTB & 500 KHZ clock	Routed to SINB/IRRX
110	ASK-IR	Inverting IRTX/SOUTB	Demodulation into SINB/IRRX
111*	ASK-IR	Inverting IRTX/SOUTB & 500 KHZ clock	Demodulation into SINB/IRRX

Note: The notation is normal mode in the IR function.

## 20.6 Logical Device 5 (Keyboard Controller)

### CR 30h. (Default 01h)

BIT	READ / WRITE	DESCRIPTION
7~1	Reserved.	
0	R / W	0: The logical device is inactive. 1: The logical device is active.

### CR 60h, 61h. (Default 00h,60h)

BIT	READ / WRITE	DESCRIPTION
7~0	R / W	These two registers select the first KBC I/O base address <100h: FFFh> on 1-byte boundary.

### CR 62h, 63h. (Default 00h,64h)

BIT	READ / WRITE	DESCRIPTION
7~0	R / W	These two registers select the second KBC I/O base address <100h: FFFh> on 1 byte boundary.

**CR 70h. (Default 01h)**

BIT	READ / WRITE	DESCRIPTION
7~4	Reserved.	
3~0	R / W	These bits select IRQ resource for KINT. (Keyboard interrupt)

**CR 72h. (Default 0Ch)**

BIT	READ / WRITE	DESCRIPTION
7~4	Reserved.	
3~0	R / W	These bits select IRQ resource for MINT. (PS/2 Mouse interrupt)

**CR F0h. (Default83h)**

BIT	READ / WRITE	DESCRIPTION
7~6	R / W	KBC clock rate selection 00: 6MHz 01: 8MHz 10: 12MHz 11: 16MHz
5~3	Reserved.	
2	R / W	0: Port 92 disable. 1: Port 92 enable.
1	R / W	0: Gate A20 software control. 1: Gate A20 hardware speed up.
0	R / W	0: KBRST software control. 1: KBRST hardware speed up.

**20.7 Logical Device 6 (Serial Peripheral Interface)****CR 30h. (Default 00h)**

BIT	READ / WRITE	DESCRIPTION
7~1	Reserved.	
0	R / W	0: Serial Peripheral Interface is inactive. 1: Activate Serial Peripheral Interface.

**CR 62h, 63h. (Default 00h)**

BIT	READ / WRITE	DESCRIPTION
7~0	R / W	These two registers select Serial Peripheral Interface I/O base address <100h: FF8h> on 1 byte boundary.



## 20.8 Logical Device 7 (GPIO6)

### CR 30h. (Default 00h)

BIT	READ / WRITE	DESCRIPTION
7~4	Reserved.	
3	R / W	0: GPIO6 is inactive.      1: GPIO6 is active.
2~0	Reserved.	

### CR F4h. (GPIO6 I/O Register; Default FFh)

BIT	READ / WRITE	DESCRIPTION
7~0	R / W	GPIO6 I/O register 0: The respective GPIO6 PIN is programmed as an output port 1: The respective GPIO6 PIN is programmed as an input port.

### CR F5h. (GPIO6 Data Register; Default 00h)

BIT	READ / WRITE	DESCRIPTION
7~0	R / W	GPIO6 Data register For output ports, the respective bits can be read and written by the pins.
	Read Only	For input ports, the respective bits can be read only from pins. Write accesses will be ignored.

### CR F6h. (GPIO6 Inversion Register; Default 00h)

BIT	READ / WRITE	DESCRIPTION
7~0	R / W	GPIO6 Inversion register 0: The respective bit and the port value are the same. 1: The respective bit and the port value are inverted. (Applies to both input and output ports)

### CR F7h. (Status Register; Default 00h)

BIT	READ / WRITE	DESCRIPTION
7~0	Read Only Read-Clear	GPIO6 Event Status Bit 7-0 corresponds to GP67-GP60, respectively. 0 : No active edge(rising/falling) has been detected 1 : An active edge(rising/falling) has been detected Read the status bit clears it to 0.



## 20.9 Logical Device 8 (WDTO# & PLED)

### CR 30h. (Default 00h)

BIT	READ / WRITE	DESCRIPTION
7~1	Reserved.	
0	R / W	0: WDTO# and PLED are inactive. 1: Activate WDTO# and PLED.

### CR F5h. (WDTO#, PLED and KBC P20 Control Mode Register; Default 00h)

BIT	READ / WRITE	DESCRIPTION
7~6	R / W	Select Power LED mode. 00: Power LED pin is driven high. 01: Power LED pin is driven low. 10: Power LED pin outputs 1Hz pulse with 50% duty cycle. 11: Power LED pin outputs 0.25Hz pulse with 50% duty cycle.
5	Reserved.	
4	R / W	WDTO# count mode is 1000 times faster. 0: Disable. 1: Enable. (If bit-3 is in Second Mode, the count mode is 1/1000 sec.) (If bit-3 is in Minute Mode, the count mode is 1/1000 min.)
3	R / W	Select WDTO# count mode. 0: Second Mode. 1: Minute Mode.
2	R / W	Enable the rising edge of a KBC reset (P20) to issue a time-out event. 0: Disable. 1: Enable.
1	R / W	Disable / Enable the WDTO# output low pulse to the KBRST# pin (PIN60) 0: Disable. 1: Enable.
0	Reserved.	





**CR F6h. (WDTO# Counter Register; Default 00h)**

BIT	READ / WRITE	DESCRIPTION
7~0	R / W	<p>Watch Dog Timer Time-out value. Writing a non-zero value to this register causes the counter to load the value into the Watch Dog Counter and start counting down. If CR F7h, bits 7 and 6 are set, any Mouse Interrupt or Keyboard Interrupt event causes the previously-loaded, non-zero value to be reloaded to the Watch Dog Counter and the count down resumes. Reading this register returns the current value in the Watch Dog Counter, not the Watch Dog Timer Time-out value.</p> <p>00h: Time-out Disable                      01h: Time-out occurs after 1 second/minute                      02h: Time-out occurs after 2 second/minutes                      03h: Time-out occurs after 3 second/minutes                      .....                      FFh: Time-out occurs after 255 second/minutes</p>

**CR F7h. (WDTO# Control & Status Register; Default 00h)**

BIT	READ / WRITE	DESCRIPTION
7	R / W	<p>Mouse interrupt reset enables watch-dog timer reload                      0: Watchdog timer is not affected by mouse interrupt.                      1: Watchdog timer is reset by mouse interrupt.</p>
6	R / W	<p>Keyboard interrupt reset enables watch-dog timer reload                      0: Watchdog timer is not affected by keyboard interrupt.                      1: Watchdog timer is reset by keyboard interrupt.</p>
5	Write "1" Only	Trigger WDTO# event. This bit is self-clearing.
4	R / W Write "0" Clear	<p>WDTO# status bit                      0: Watchdog timer is running.                      1: Watchdog timer issues time-out event.</p>
3~0	R / W	These bits select the IRQ resource for the WDTO#. (02h for SMI# event.)



## 20.10 Logical Device 9 (GPIO2, GPIO3, GPIO4, GPIO5)

### CR 30h. (Default 00h)

BIT	READ / WRITE	DESCRIPTION
7~4	Reserved.	
3	R / W	0: GPIO5 is inactive. 1: GPIO5 is active
2	R / W	0: GPIO4 is inactive. 1: GPIO4 is active.
1	R / W	0: GPIO3 is inactive. 1: GPIO3 is active.
0	R / W	0: GPIO2 is inactive. 1: GPIO2 is active.

### CR E0h. (GPIO5 I/O Register; Default FFh)

BIT	READ / WRITE	DESCRIPTION
7~0	R / W	GPIO5 I/O register 0: The respective GPIO5 PIN is programmed as an output port 1: The respective GPIO5 PIN is programmed as an input port.

### CR E1h. (GPIO5 Data Register; Default 00h)

BIT	READ / WRITE	DESCRIPTION
7~0	R / W	GPIO5 Data register For output ports, the respective bits can be read and written by the pins.
	Read Only	For input ports, the respective bits can only be read by the pins. Write accesses are ignored.

### CR E2h. (GPIO5 Inversion Register; Default 00h)

BIT	READ / WRITE	DESCRIPTION
7~0	R / W	GPIO5 Inversion register 0: The respective bit and the port value are the same. 1: The respective bit and the port value are inverted. (Applies to both input and output ports)

### CR E3h. (GPIO2 Register; Default FFh)

BIT	READ / WRITE	DESCRIPTION
7~0	R / W	GPIO2 I/O register 0: The respective GPIO2 PIN is programmed as an output port 1: The respective GPIO2 PIN is programmed as an input port

**CR E4h. (GPIO2 Data Register; Default 00h)**

BIT	READ / WRITE	DESCRIPTION
7~0	R / W	GPIO2 Data register For output ports, the respective bits can be read and written by the pins.
	Read Only	For input ports, the respective bits can only be read by the pins. Write accesses are ignored.

**CR E5h. (GPIO2 Inversion Register; Default 00h)**

BIT	READ / WRITE	DESCRIPTION
7~0	R / W	GPIO2 Inversion register 0: The respective bit and the port value are the same. 1: The respective bit and the port value are inverted. (Applies to both input and output ports)

**CR E6h. (GPIO2 Status Register; Default 00h)**

BIT	READ / WRITE	DESCRIPTION
7~0	Read Only Read-Clear	GPIO2 Event Status Bit 7-0 corresponds to GP27-GP20, respectively. 0 : No active edge(rising/falling) has been detected 1 : An active edge(rising/falling) has been detected Read the status bit clears it to 0.

**CR E7h. (GPIO3 Status Register; Default 00h)**

BIT	READ / WRITE	DESCRIPTION
7~0	Read Only Read-Clear	GPIO3 Event Status Bit 7-0 corresponds to GP37-GP30, respectively. 0 : No active edge(rising/falling) has been detected 1 : An active edge(rising/falling) has been detected Read the status bit clears it to 0.

**CR E8h. (GPIO4 Status Register; Default 00h)**

BIT	READ / WRITE	DESCRIPTION
7~0	Read Only Read-Clear	GPIO4 Event Status Bit 7-0 corresponds to GP47-GP40, respectively. 0 : No active edge(rising/falling) has been detected 1 : An active edge(rising/falling) has been detected Reading the status bit clears it to 0.

**CR E9h. (GPIO5 Status Register; Default 00h)**

BIT	READ / WRITE	DESCRIPTION
7	Read Only Read-Clear	GPIO5 Event Status Bit 7-0 corresponds to GP57-GP50, respectively. 0 : No active edge(rising/falling) has been detected 1 : An active edge(rising/falling) has been detected Reading the status bit clears it to 0.

**CR F0h. (GPIO3 I/O Register; Default FFh)**

BIT	READ / WRITE	DESCRIPTION
7~0	R / W	GPIO3 I/O register 0: The respective GPIO3 PIN is programmed as an output port 1: The respective GPIO3 PIN is programmed as an input port.

**CR F1h. (GPIO3 Data Register; Default 00h)**

BIT	READ / WRITE	DESCRIPTION
7~0	R / W	GPIO3 Data register For output ports, the respective bits can be read and written by the pins.
	Read Only	For input ports, the respective bits can only be read by the pins. Write accesses are ignored.

**CR F2h. (GPIO3 Inversion Register; Default 00h)**

BIT	READ / WRITE	DESCRIPTION
7~0	R / W	GPIO3 Inversion register 0: The respective bit and the port value are the same. 1: The respective bit and the port value are inverted. (Applies to both input and output ports)

**CR F3h. (Suspend LED Mode Register; Default 00h) (VBAT power)**

BIT	READ / WRITE	DESCRIPTION
7~6	R / W	Select Suspend LED mode. 00: Suspend LED pin is tri-stated. 01: Suspend LED pin is driven low. 10: Suspend LED pin outputs 1Hz pulse with 50% duty cycle. 11: Suspend LED pin outputs 0.25Hz pulse with 50% duty cycle.
5~0	Reserved.	

**CR F4h. (GPIO4 I/O Register; Default FFh)**

BIT	READ / WRITE	DESCRIPTION
7~0	R / W	GPIO4 I/O register 0: The respective GPIO4 PIN is programmed as an output port 1: The respective GPIO4 PIN is programmed as an input port.

**CR F5h. (GPIO4 Data Register; Default 00h)**

BIT	READ / WRITE	DESCRIPTION
7~0	R / W	GPIO4 Data register For output ports, the respective bits can be read and written by the pins.
	Read Only	For input ports, the respective bits can only be read by the pins. Write accesses are ignored.

**CR F6h. (GPIO4 Inversion Register; Default 00h)**

BIT	READ / WRITE	DESCRIPTION
7~0	R / W	GPIO4 Inversion register 0: The respective bit and the port value are the same. 1: The respective bit and the port value are inverted. (Applies to both input and output ports)

**CR F7h. (GPIO4 Multi-function Select Register; Default 00h)**

BIT	READ / WRITE	DESCRIPTION
7	R / W	0: GPIO47 1: GPIO47 → SUSLED
6	R / W	0: GPIO46 1: GPIO46 → WDTO#
5	R / W	0: GPIO45 1: GPIO45 → SUSLED
4	R / W	0: GPIO44 1: GPIO44 → WDTO#
3	R / W	0: GPIO43 1: GPIO43 → SUSLED
2	R / W	0: GPIO42 1: GPIO42 → WDTO#
1	R / W	0: GPIO41 1: GPIO41 → SUSLED
0	R / W	0: GPIO40 1: GPIO40 → WDTO#

**CR FEh. (GPIO3 Input Detected Type Register; Default 00h)**

BIT	READ / WRITE	DESCRIPTION
7	R / W	Reserved.
6	R / W	0: Enable GP35 input de-bouncer 1: Disable GP35 input de-bouncer
5	R / W	0: Enable GP31 input de-bouncer 1: Disable GP31 input de-bouncer
4	R / W	0: Enable GP30 input de-bouncer 1: Disable GP30 input de-bouncer
3	Reserved.	
2	R / W	0: GP35 trigger type : edge 1: GP35 trigger type : level
1	R / W	0: GP31 trigger type : edge 1: GP31 trigger type : level
0	R / W	0: GP30 trigger type : edge 1: GP30 trigger type : level

**20.11 Logical Device A (ACPI)**

(CR30, CR70 are VCC powered; CRE0~F7 are VRTC powered)

**CR 30h. (Default 00h)**

BIT	READ / WRITE	DESCRIPTION
7~1	Reserved.	
0	R / W	0: Logical device is inactive. 1: Logical device is active.

**CR 70h. (Default 00h)**

BIT	READ / WRITE	DESCRIPTION
7~4	Reserved.	
3~0	R / W	These bits select the IRQ resource for PME#.



## CR E0h. (Default 01h) (VBAT power)

BIT	READ / WRITE	DESCRIPTION																												
7	R / W	DIS_PSIN => Disable the panel switch input to turn on the system power supply. 0: PSIN is wire-AND and connected to PSOUT#. 1: PSIN is blocked and cannot affect PSOUT#.																												
6	R / W	Enable KBC wake-up 0: Disable keyboard wake-up function via PSOUT#. 1: Enable keyboard wake-up function via PSOUT#.																												
5	R / W	Enable Mouse wake-up 0: Disable mouse wake-up function via PSOUT#. 1: Enable mouse wake-up function via PSOUT#.																												
4	R / W	MSRKEY => Three keys (ENMDAT_UP, CRE6[7]; MSRKEY, CRE0[4]; MSXKEY, CRE0[1]) define the combinations of the mouse wake-up events. Please see the following table for the details. <table border="1" data-bbox="522 919 1403 1220"> <thead> <tr> <th>ENMDAT_UP</th> <th>MSRKEY</th> <th>MSXKEY</th> <th>Wake-up event</th> </tr> </thead> <tbody> <tr> <td>1</td> <td>x</td> <td>1</td> <td>Any button clicked or any movement.</td> </tr> <tr> <td>1</td> <td>x</td> <td>0</td> <td>One click of left or right button.</td> </tr> <tr> <td>0</td> <td>0</td> <td>1</td> <td>One click of the left button.</td> </tr> <tr> <td>0</td> <td>1</td> <td>1</td> <td>One click of the right button.</td> </tr> <tr> <td>0</td> <td>0</td> <td>0</td> <td>Two clicks of the left button.</td> </tr> <tr> <td>0</td> <td>1</td> <td>0</td> <td>Two clicks of the right button.</td> </tr> </tbody> </table>	ENMDAT_UP	MSRKEY	MSXKEY	Wake-up event	1	x	1	Any button clicked or any movement.	1	x	0	One click of left or right button.	0	0	1	One click of the left button.	0	1	1	One click of the right button.	0	0	0	Two clicks of the left button.	0	1	0	Two clicks of the right button.
ENMDAT_UP	MSRKEY	MSXKEY	Wake-up event																											
1	x	1	Any button clicked or any movement.																											
1	x	0	One click of left or right button.																											
0	0	1	One click of the left button.																											
0	1	1	One click of the right button.																											
0	0	0	Two clicks of the left button.																											
0	1	0	Two clicks of the right button.																											
3	Reserved.																													
2	R / W	Keyboard / Mouse swap enable 0: Normal mode. 1: Keyboard / Mouse ports are swapped.																												
1	R / W	MSXKEY => Three keys (ENMDAT_UP, CRE6[7]; MSRKEY, CRE0[4]; MSXKEY, CRE0[1]) define the combinations of the mouse wake-up events. Please check out the table in CRE0[4] for the detailed.																												
0	R / W	KBXKEY => 0: Only the pre-determined key combination in sequence can wake up the system. 1: Any character received from the keyboard can wake up the system.																												

**CR E1h. (KBC Wake-Up Index Register; Default 00h) (VSB power)**

BIT	READ / WRITE	DESCRIPTION
7~0	R / W	Keyboard wake-up index register. This is the index register of CRE2, which is the access window for the keyboard's pre-determined key key-combination characters. The first set of wake-up keys is in of 0x00 - 0x0E, the second set 0x30 – 0x3E, and the third set 0x40 – 0x4E. Incoming key combinations can be read through 0x10 – 0x1E.

**CR E2h. (KBC Wake-Up Data Register; Default FFh) (VSB power)**

BIT	READ / WRITE	DESCRIPTION
7~0	R / W	Keyboard wake-up data register. This is the data register for the keyboard's pre-determined key-combination characters, which is indexed by CRE1.

**CR E3h. (Event Status Register; Default 08h)**

BIT	READ / WRITE	DESCRIPTION
7~6	Reserved.	
5	Read Only Read-Clear	This status flag indicates VSB power off/on.
4	Read Only Read-Clear	If E4[7] is 1 => 0: When power-loss occurs and the VSB power is on, turn on system power. 1: When power-loss occurs and the VSB power is on, turn off system power. If E4[7] is 0 => This bit is always 0.
3	Read Only Read-Clear	Thermal shutdown status. 0: No thermal shutdown event issued. 1: Thermal shutdown event issued.
2	Read Only Read-Clear	PSIN_STS 0: No PSIN event issued. 1: PSIN event issued.
1	Read Only Read-Clear	MSWAKEUP_STS => The bit is latched by the mouse wake-up event. 0: No mouse wake-up event issued. 1: Mouse wake-up event issued.
0	Read Only Read-Clear	KBWAKEUP_STS => The bit is latched by the keyboard wake-up event. 0: No keyboard wake-up event issued. 1: Keyboard wake-up event issued.





## CR E4h. (Default 00h)

BIT	READ / WRITE	DESCRIPTION
7	R / W	Disable / Enable to issue a 4s long PSOUT# low pulse when the system returns from power loss state and is supposed to be "off" as described in CRE4[6:5], Logical Device A. (VBAT) 0: Disable. 1: Enable.
6~5	R / W	Power-loss control bits => (VBAT) 00: System always turns off when it returns from power-loss state. 01: System always turns on when it returns from power-loss state. 10: System turns off / on when it returns from power-loss state depending on the state before the power loss. 11: User defines the state before power loss.(i.e. the last state set of CRE6[4])
4	R / W	VSBGATE# Enable bit => 0: Disable. 1: Enable. * This bit is available both for UBE and UBF version
3	R / W	Keyboard wake-up options. (LRESET#) 0: Password or sequence hot keys programmed in the registers. 1: Any key.
2	R / W	Enable the hunting mode for all wake-up events set in CRE0. This bit is cleared when any wake-up events is captured. (LRESET#) 0: Disable. 1: Enable.
1~0	Reserved.	

## CR E5h. (GPIOs Reset Source Register; Default 00)

BIT	READ / WRITE	DESCRIPTION
7~ 5	Reserved.	
4	R / W	VID_MRST 0: VID reset by LRESET#. 1: VID reset by PWROK.
3	R / W	GP23_MRST 0: GP23 reset by LRESET#. 1: GP23 reset by PWROK.
2	R / W	GP22_MRST 0: GP22 reset by LRESET#. 1: GP22 reset by PWROK.



Continued

BIT	READ / WRITE	DESCRIPTION
1		Reserved.
0	R / W	ATXPGD signal to control PWROK and PWROK2 generation 0: Enable. 1: Disable. * This bit is available both for UBE and UBF version

**CR E6h. (Default 1Ch)**

BIT	READ / WRITE	DESCRIPTION
7	R / W	ENMDAT => <b>(VSB)</b> Three keys (ENMDAT_UP, CRE6[7]; MSRKEY, CRE0[4]; MSXKEY, CRE0[1]) define the combinations of the mouse wake-up events. Please see the table in CRE0, bit 4 for the details.
6		Reserved.
5	R / W	CASEOPEN Clear Control. <b>(VSB)</b> Write 1 to this bit to clear CASEOPEN status. This bit will not clear the status itself. Please write 0 after an event is cleared. The function is the same as Index 46h bit 7 of H/W Monitor part.
4	R / W	Power-loss Last State Flag. <b>(VBAT)</b> 0: ON 1: OFF.
3	R / W	PWROK_DEL (first stage) <b>(VSB)</b> Set the delay time when rising from PWROK_LP to PWROK_ST. 0: 300 ~ 500 mS. 1: 200 ~ 300 mS.
2~1	R / W	PWROK_DEL <b>(VSB)</b> Set the delay time when rising from PWROK_ST to PWROK. 00: No delay time.                      01: Delay 32 mS 10: 96 mS                                      11: Delay 250 mS
0	R / W-Clear	PWROK_TRIG => Write 1 to re-trigger the PWROK signal from low to high.



## CR E7h. (Default 00h)

BIT	READ / WRITE	DESCRIPTION
7	R / W	<b>ENKD3 =&gt; (VSB)</b> Enable the third set of keyboard wake-up key combination. Its values are accessed through keyboard wake-up index register (CRE1) and keyboard wake-up data register (CRE2) at the index from 40h to 4eh. 0: Disable the third set of the key combinations. 1: Enable the third set of the key combinations.
6	R / W	<b>ENKD2 =&gt; (VSB)</b> Enable the second set of keyboard wake-up key combination. Its values are accessed through keyboard wake-up index register (CRE1) and keyboard wake-up data register (CRE2) at the index from 30h to 3eh. 0: Disable the second set of the key combinations. 1: Enable the second set of the key combinations.
5	R / W	<b>ENWIN98KEY =&gt; (VSB)</b> Enable Win98 keyboard dedicated key to wake-up system via PSOUT# when keyboard wake-up function is enabled. 0: Disable Win98 keyboard wake-up. 1: Enable Win98 keyboard wake-up.
4	R / W	<b>EN_ONPSOUT (VBAT)</b> Disable/Enable to issue a 0.5s long PSOUT# low pulse when system returns from power loss state and is supposed to be on as described in CRE4[6:5], logic device A. (for SiS & VIA chipsets) 0: Disable. 1: Enable.
3	R / W	<b>Select WDTO# reset source (VSB)</b> 0: Watchdog timer is reset by LRESET#. 1: Watchdog timer is reset by PWROK.
2~1	Reserved.	
0	R / W	<b>Hardware Monitor RESET source select (VBAT)</b> 0: PWROK. 1: LRESET#.

CR E8h. (Reserved)

CR E9h. (Reserved)

**CR F2h. (Default 7Ch) (VSB Power)**

BIT	READ / WRITE	DESCRIPTION
7	Reserved.	
6	R / W	Enable RSTOUT4# function. 0: Disable RSTOUT4#. 1: Enable RSTOUT4#.
5	R / W	Enable RSTOUT3# function. 0: Disable RSTOUT3#. 1: Enable RSTOUT3#.
4	R / W	Enable RSTOUT2# function. 0: Disable RSTOUT2#. 1: Enable RSTOUT2#.
3	R / W	Enable RSTOUT1# function. 0: Disable RSTOUT1#. 1: Enable RSTOUT1#.
2	R / W	Enable RSTOUT0# function. 0: Disable RSTOUT0#. 1: Enable RSTOUT0#.
1	Reserved.	
0	R / W	EN_PME => 0: Disable PME. 1: Enable PME.

**CR F3h. (Default 00h)**

BIT	READ / WRITE	DESCRIPTION
7~6	Reserved.	
5	R / W-Clear	PME status of the Mouse IRQ event. Write 1 to clear this status.
4	R / W-Clear	PME status of the KBC IRQ event. Write 1 to clear this status.
3	R / W-Clear	PME status of the PRT IRQ event. Write 1 to clear this status.
2	R / W-Clear	PME status of the FDC IRQ event. Write 1 to clear this status.
1	R / W-Clear	PME status of the URA IRQ event. Write 1 to clear this status.
0	R / W-Clear	PME status of the URB IRQ event. Write 1 to clear this status.

**CR F4h. (Default 00h)**

BIT	READ / WRITE	DESCRIPTION
7~4	Reserved.	
3	R / W-Clear	PME status of the HM IRQ event. Write 1 to clear this status.
2	R / W-Clear	PME status of the WDTO# event. Write 1 to clear this status.
1	Reserved.	
0	R / W-Clear	PME status of the RIB event. Write 1 to clear this status.

**CR F6h. (Default 00h) (VSB Power)**

BIT	READ / WRITE	DESCRIPTION
7~6	Reserved.	
5	R / W	0: Disable PME interrupt of the Mouse IRQ event. 1: Enable PME interrupt of the Mouse IRQ event.
4	R / W	0: Disable PME interrupt of the KBC IRQ event. 1: Enable PME interrupt of the KBC IRQ event.
3	R / W	0: Disable PME interrupt of the PRT IRQ event. 1: Enable PME interrupt of the PRT IRQ event.
2	R / W	0: Disable PME interrupt of the FDC IRQ event. 1: Enable PME interrupt of the FDC IRQ event.
1	R / W	0: Disable PME interrupt of the URA IRQ event. 1: Enable PME interrupt of the URA IRQ event.
0	R / W	0: Disable PME interrupt of the URB IRQ event. 1: Enable PME interrupt of the URB IRQ event.

**CR F7h. (Default 00h) (VSB Power)**

BIT	READ / WRITE	DESCRIPTION
7~4	Reserved.	
3	R / W	0: Disable PME interrupt of the HM IRQ event. 1: Enable PME interrupt of the HM IRQ event.
2	R / W	0: Disable PME interrupt of the WDTO# event. 1: Enable PME interrupt of the WDTO# event.
1	Reserved.	
0	R / W	0: Disable PME interrupt of the RIB event. 1: Enable PME interrupt of the RIB event.

**CR FEh. (GPIO3 Event Route Selection Register; Default 00h)**

BIT	READ / WRITE	DESCRIPTION
7	R / W	Reserved.
6	R / W	0: Disable GP35 event route to PSOUT#. 1: Enable GP35 event route to PSOUT#.
5	R / W	0: Disable GP31 event route to PSOUT#. 1: Enable GP31 event route to PSOUT#.
4	R / W	0: Disable GP30 event route to PSOUT#. 1: Enable GP30 event route to PSOUT#.
3	Reserved.	
2	R / W	0: Disable GP35 event route to PME#. 1: Enable GP35 event route to PME#.
1	R / W	0: Disable GP31 event route to PME#. 1: Enable GP31 event route to PME#.
0	R / W	0: Disable GP30 event route to PME#. 1: Enable GP30 event route to PME#.

**20.12 Logical Device B (Hardware Monitor)****CR 30h. (Default 00h)**

BIT	READ / WRITE	DESCRIPTION
7~1	Reserved.	
0	R / W	0: Logical device is inactive. 1: Logical device is active.

**CR 60h, 61h. (Default 00h, 00h)**

BIT	READ / WRITE	DESCRIPTION
7~0	R / W	These two registers select the HM base address <100h : FFEh> along a two-byte boundary.

**CR 70h. (Default 00h)**

BIT	READ / WRITE	DESCRIPTION
7~4	Reserved.	
3~0	R / W	These bits select the IRQ resource for HM.

**CR F0h. (VID Control Register; Default 81h)**

BIT	READ / WRITE	DESCRIPTION
7	R / W	VID I/O Control 0: VID output mode. 1: VID input mode.
6	R / W	VIDAMD input level select 0: VID is GTL level. 1: VID is AMD VRM level.
5-0	Reserved.	

**CR F1h. (VID Data Register; Default 00h)**

BIT	READ / WRITE	DESCRIPTION
7~0	R / W	VID[7:0] Data Register. (For Input/Output both use)

**CR F2h. (FAN Strapping Status Register; Default 00h) (VCC Power)**

BIT	READ / WRITE	DESCRIPTION
7~2	Reserved.	
1	Read Only	FAN_SET2 strapping status. This bit is strapped by pin 83(SOUTB). 0: Initial speed is 100%. 1: Initial speed is 50%.
0	Read Only	FAN_SET strapping status. This bit is strapped by pin 117(PLED). 0: Initial speed is 100%. 1: Initial speed is 50%.



### 20.13 Logical Device C (PECI, SST)

#### CR E0h. (Agent Configuration Register; Default 00h)

BIT	READ / WRITE	DESCRIPTION
7	R / W	Agt4EN (Agent 4 Enable Bit) 0: Agent 4 is disabled. 1: Agent 4 is enabled.
6	R / W	Agt3EN (Agent 3 Enable Bit) 0: Agent 3 is disabled. 1: Agent 3 is enabled.
5	R / W	Agt2EN (Agent 2 Enable Bit) 0: Agent 2 is disabled. 1: Agent 2 is enabled.
4	R / W	Agt1EN (Agent 1 Enable Bit) 0: Agent 1 is disabled. 1: Agent 1 is enabled.
3	R / W	RTD4 (Agent 4 Return Domain 1 Enable Bit. Functions only when Agt4D1 is set to 1) 0: Agent 4 always returns the relative temperature from domain 0. 1: Agent 4 always returns the relative temperature from domain 1.
2	R / W	RTD3 (Agent 3 Return Domain 1 Enable Bit. Functions only when Agt3D1 is set to 1) 0: Agent 3 always returns the relative temperature from domain 0. 1: Agent 3 always returns the relative temperature from domain 1.
1	R / W	RTD2 (Agent 2 Return Domain 1 Enable Bit. Functions only when Agt2D1 is set to 1) 0: Agent 2 always returns the relative temperature from domain 0. 1: Agent 2 always returns the relative temperature from domain 1.
0	R / W	RTD1 (Agent 1 Return Domain 1 Enable Bit. Functions only when Agt1D1 is set to 1) 0: Agent 1 always returns the relative temperature from domain 0. 1: Agent 1 always returns the relative temperature from domain 1.

**Note.** Agent 1 ~ Agent 4 represent the addresses of PECI devices is from 0x30h to 0x33h respectively.

#### CR E1h. (Agent 1 TBase Register; Default 48h)

BIT	READ / WRITE	DESCRIPTION
7	Reserved	
6~0	R / W	Agent 1 TBase must always be a positive value; a negative value will cause abnormal temperature responses. (Note 1)



**CR E2h. (Agent 2 TBase Register; Default 48h)**

BIT	READ / WRITE	DESCRIPTION
7	Reserved.	
6~0	R / W	Agent 2 TBase must always be a positive value; a negative value will cause abnormal temperature responses. (Note 1)

**CR E3h. (Agent 3 TBase Register; Default 48h)**

BIT	READ / WRITE	DESCRIPTION
7	Reserved.	
6~0	R / W	Agent 3 TBase must always be a positive value; a negative value will cause abnormal temperature responses. (Note 1)

**CR E4h. (Agent 4 TBase Register; Default 48h)**

BIT	READ / WRITE	DESCRIPTION
7	Reserved.	
6~0	R / W	Agent 4 TBase must always be a positive value; a negative value will cause abnormal temperature responses. (Note 1)

**Note 1:** TBase is a temperature reference based on the experiment of processor actual temperature. For more detail, please refer to Chapter 7.5.

**CR E5h. (PECI Register; Default 00h)**

BIT	READ / WRITE	DESCRIPTION
7	R / W	Agt4D1 (Agent 4 Domain 1 Enable Bit) 0: Agent 4 does not have domain 1. 1: Agent 4 has domain 1.
6	R / W	Agt3D1 (Agent 3 Domain 1 Enable Bit) 0: Agent 3 does not have domain 1. 1: Agent 3 has domain 1.
5	R / W	Agt2D1 (Agent 2 Domain 1 Enable Bit) 0: Agent 2 does not have domain 1. 1: Agent 2 has domain 1.
4	R / W	Agt1D1 (Agent 1 Domain 1 Enable Bit) 0: Agent 1 does not have domain 1. 1: Agent 1 has domain 1.



Continued

BIT	READ / WRITE	DESCRIPTION
3~2	Reserved	
1	R / W	Return High Temperature 0: The temperature of each agent is returned from domain 0 or domain 1, which is controlled by CRE0 bit 0~3. 1: Return the highest temperature in domain 0 and domain 1 of individual Agent.
0	R / W	PECISB_EN: 0: PECL host is controlled by IO 1: PECL host is the other (i.e. South Bridge).

**CR E8h. (PECL Warning Flag Register; Default 00h)**

BIT	READ / WRITE	DESCRIPTION
7	R / W	Agent 4 Absent / Alert Bit 0: Agent 4 is detected and has valid FCS 1: Agent 4 cannot be detected or has invalid FCS in the previous 3 transactions
6	R / W	Agent 3 Absent / Alert Bit 0: Agent 3 is detected and has valid FCS 1: Agent 3 cannot be detected or has invalid FCS in the previous 3 transactions
5	R / W	Agent 2 Absent / Alert Bit 0: Agent 2 is detected and has valid FCS 1: Agent 2 cannot be detected or has invalid FCS in the previous 3 transactions
4	R / W	Agent 1 Absent / Alert Bit 0: Agent 1 is detected and has valid FCS 1: Agent 1 cannot be detected or has invalid FCS in the previous 3 transactions
3~2	Reserved.	
1~0	R/W	PECL speed selected 00: The PECL speed is 1.5 MHz 01: The PECL speed is 750 KHz 10: The PECL speed is 375 KHz 11: The PECL speed is 187.5 KHz

**CR F1h. (SST Address Register; Default 48h)**

BIT	READ / WRITE	DESCRIPTION
7~0	R / W	SST address

**CR FEh. (PECI Agent Relative Temperature Register; Default 00h)**

BIT	READ / WRITE	DESCRIPTION
7~0	Read Only	This register shows the retrieved High Byte raw data from PECE interface.

**CR FFh. (PECI Agent Relative Temperature Register; Default 00h)**

BIT	READ / WRITE	DESCRIPTION
7~0	Read Only	This register shows the retrieved Low Byte raw data from PECE interface

**Note:** PECE relative temperature data is formatted in a 16-bit two's complement value representing a number of 1/64°C.



## 21. SPECIFICATIONS

### 21.1 Absolute Maximum Ratings

SYMBOL	PARAMETER	RATING	UNIT
3VCC	Power Supply Voltage (3.3V)	-0.5 to 6.5	V
VI	Input Voltage	-0.5 to 3VCC+0.5	V
	Input Voltage (5V tolerance)	-0.5 to 6	V
VBAT	RTC Battery Voltage VBAT	2.2 to 4.0	V
TA	Operating Temperature	0 to +70	°C
TSTG	Storage Temperature	-55 to +150	°C

**Note:** Exposure to conditions beyond those listed under Absolute Maximum Ratings may adversely affect the life and reliability of the device.

### 21.2 DC CHARACTERISTICS

( $T_a = 0^\circ\text{C}$  to  $70^\circ\text{C}$ ,  $V_{DD} = 3.3\text{V} \pm 5\%$ ,  $V_{SS} = 0\text{V}$ )

PARAMETER	SYM	MIN	TYP	MAX.	UNIT	CONDITIONS
RTC Battery Quiescent Current	IBAT			2.4	$\mu\text{A}$	VBAT = 2.5 V
ACPI Stand-by Power Supply Quiescent Current	ISB			2.0	mA	VSB = 3.3 V, All ACPI pins are not connected.
<b>I/O<sub>8t</sub> – TTL-level, bi-directional pin with 8mA source-sink capability</b>						
Input Low Voltage	VIL			0.8	V	
Input High Voltage	VIH	2.0			V	
Output Low Voltage	VOL			0.4	V	IOL = 8 mA
Output High Voltage	VOH	2.4			V	IOH = - 8 mA
Input High Leakage	ILIH			+10	$\mu\text{A}$	VIN = 3.3V
Input Low Leakage	ILIL			-10	$\mu\text{A}$	VIN = 0V
<b>I/O<sub>12t</sub> – TTL-level, bi-directional pin with 12mA source-sink capability</b>						
Input Low Voltage	VIL			0.8	V	
Input High Voltage	VIH	2.0			V	
Output Low Voltage	VOL			0.4	V	IOL = 12 mA
Output High Voltage	VOH	2.4			V	IOH = -12 mA
Input High Leakage	ILIH			+10	$\mu\text{A}$	VIN = 3.3V
Input Low Leakage	ILIL			-10	$\mu\text{A}$	VIN = 0V



## DC CHARACTERISTICS, continued

PARAMETER	SYM	MIN	TYP	MAX.	UNIT	CONDITIONS
<b>I/O<sub>24t</sub> – TTL-level, bi-directional pin with 24mA source-sink capability</b>						
Input Low Voltage	V <sub>IL</sub>			0.8	V	
Input High Voltage	V <sub>IH</sub>	2.0			V	
Output Low Voltage	V <sub>OL</sub>			0.4	V	I <sub>OL</sub> = 24 mA
Output High Voltage	V <sub>OH</sub>	2.4			V	I <sub>OH</sub> = -24 mA
Input High Leakage	I <sub>LIH</sub>			+10	μA	V <sub>IN</sub> = 3.3V
Input Low Leakage	I <sub>LIL</sub>			-10	μA	V <sub>IN</sub> = 0V
<b>I/O<sub>12tp3</sub> – 3.3V TTL-level, bi-directional pin with 12mA source-sink capability</b>						
Input Low Voltage	V <sub>IL</sub>			0.8	V	
Input High Voltage	V <sub>IH</sub>	2.0			V	
Output Low Voltage	V <sub>OL</sub>			0.4	V	I <sub>OL</sub> = 12 mA
Output High Voltage	V <sub>OH</sub>	2.4			V	I <sub>OH</sub> = -12 mA
Input High Leakage	I <sub>LIH</sub>			+10	μA	V <sub>IN</sub> = 3.3V
Input Low Leakage	I <sub>LIL</sub>			-10	μA	V <sub>IN</sub> = 0V
<b>I/O<sub>12ts</sub> – TTL-level, Schmitt-trigger, bi-directional pin with 12mA source-sink capability</b>						
Input Low Threshold Voltage	V <sub>t-</sub>	0.5	0.8	1.1	V	
Input High Threshold Voltage	V <sub>t+</sub>	1.6	2.0	2.4	V	
Hysteresis	V <sub>TH</sub>	0.5	1.2		V	V <sub>CC</sub> =3.3V
Output Low Voltage	V <sub>OL</sub>			0.4	V	I <sub>OL</sub> = 12 mA
Output High Voltage	V <sub>OH</sub>	2.4			V	I <sub>OH</sub> = -12 mA
Input High Leakage	I <sub>LIH</sub>			+10	μA	V <sub>IN</sub> = 3.3V
Input Low Leakage	I <sub>LIL</sub>			-10	μA	V <sub>IN</sub> = 0V
<b>I/O<sub>24ts</sub> – TTL-level, Schmitt-trigger, bi-directional pin with 24mA source-sink capability</b>						
Input Low Threshold Voltage	V <sub>t-</sub>	0.5	0.8	1.1	V	
Input High Threshold Voltage	V <sub>t+</sub>	1.6	2.0	2.4	V	
Hysteresis	V <sub>TH</sub>	0.5	1.2		V	V <sub>CC</sub> = 3.3V
Output Low Voltage	V <sub>OL</sub>			0.4	V	I <sub>OL</sub> = 24 mA
Output High Voltage	V <sub>OH</sub>	2.4			V	I <sub>OH</sub> = -24 mA
Input High Leakage	I <sub>LIH</sub>			+10	μA	V <sub>IN</sub> = 3.3V
Input Low Leakage	I <sub>LIL</sub>			-10	μA	V <sub>IN</sub> = 0V



## DC CHARACTERISTICS, continued

PARAMETER	SYM	MIN	TYP	MAX.	UNIT	CONDITIONS
<b>I/O<sub>24tsp3</sub> – 3.3V TTL-level, Schmitt-trigger, bi-directional pin with 24mA source-sink capability</b>						
Input Low Threshold Voltage	V <sub>t-</sub>	0.5	0.8	1.1	V	
Input High Threshold Voltage	V <sub>t+</sub>	1.6	2.0	2.4	V	
Hysteresis	V <sub>TH</sub>	0.5	1.2		V	V <sub>CC</sub> =3.3V
Output Low Voltage	V <sub>OL</sub>			0.4	V	I <sub>OL</sub> = 24 mA
Output High Voltage	V <sub>OH</sub>	2.4			V	I <sub>OH</sub> = -24 mA
Input High Leakage	I <sub>LIH</sub>			+10	μA	V <sub>IN</sub> = 3.3V
Input Low Leakage	I <sub>LIL</sub>			-10	μA	V <sub>IN</sub> = 0V
<b>I/OD<sub>12t</sub> – TTL-level, bi-directional pin and open-drain output with 12mA sink capability</b>						
Input Low Voltage	V <sub>IL</sub>			0.8	V	
Input High Voltage	V <sub>IH</sub>	2.0			V	
Output Low Voltage	V <sub>OL</sub>			0.4	V	I <sub>OL</sub> = 12 mA
Input High Leakage	I <sub>LIH</sub>			+10	μA	V <sub>IN</sub> = 3.3V
Input Low Leakage	I <sub>LIL</sub>			-10	μA	V <sub>IN</sub> = 0V
<b>I/OD<sub>16t</sub> – TTL-level, bi-directional pin and open-drain output with 16mA sink capability</b>						
Input Low Voltage	V <sub>IL</sub>			0.8	V	
Input High Voltage	V <sub>IH</sub>	2.0			V	
Output Low Voltage	V <sub>OL</sub>			0.4	V	I <sub>OL</sub> = 16 mA
Input High Leakage	I <sub>LIH</sub>			+10	μA	V <sub>IN</sub> = 3.3V
Input Low Leakage	I <sub>LIL</sub>			-10	μA	V <sub>IN</sub> = 0V
<b>I/OD<sub>24t</sub> – TTL-level, bi-directional pin and open-drain output with 24mA sink capability</b>						
Input Low Voltage	V <sub>IL</sub>			0.8	V	
Input High Voltage	V <sub>IH</sub>	2.0			V	
Output Low Voltage	V <sub>OL</sub>			0.4	V	I <sub>OL</sub> = 24 mA
Input High Leakage	I <sub>LIH</sub>			+10	μA	V <sub>IN</sub> = 3.3V
Input Low Leakage	I <sub>LIL</sub>			-10	μA	V <sub>IN</sub> = 0V
<b>I/O<sub>12tp3</sub> – 3.3V TTL-level, bi-directional pin and open-drain output with 12mA source-sink capability</b>						
Input Low Voltage	V <sub>IL</sub>			0.8	V	
Input High Voltage	V <sub>IH</sub>	2.0			V	
Output Low Voltage	V <sub>OL</sub>			0.4	V	I <sub>OL</sub> = 12 mA
Output High Voltage	V <sub>OH</sub>	2.4			V	I <sub>OH</sub> = -12 mA
Input High Leakage	I <sub>LIH</sub>			+10	μA	V <sub>IN</sub> = 3.3V
Input Low Leakage	I <sub>LIL</sub>			-10	μA	V <sub>IN</sub> = 0V



## DC CHARACTERISTICS, continued

PARAMETER	SYM	MIN	TYP	MAX.	UNIT	CONDITIONS
<b>I/OD<sub>16ts</sub> – TTL–level, Schmitt-trigger, bi-directional pin and open-drain output with 16mA sink capability</b>						
Input Low Threshold Voltage	V <sub>t-</sub>	0.5	0.8	1.1	V	
Input High Threshold Voltage	V <sub>t+</sub>	1.6	2.0	2.4	V	
Hysteresis	V <sub>TH</sub>	0.5	1.2		V	V <sub>CC</sub> =3.3V
Output Low Voltage	V <sub>OL</sub>			0.4	V	I <sub>OL</sub> = 16 mA
Input High Leakage	I <sub>LIH</sub>			+10	μA	V <sub>IN</sub> = 3.3V
Input Low Leakage	I <sub>LIL</sub>			-10	μA	V <sub>IN</sub> = 0V
<b>I/OD<sub>24ts</sub> – TTL level, Schmitt-trigger, bi-directional pin and open-drain output with 24mA sink capability</b>						
Input Low Threshold Voltage	V <sub>t-</sub>	0.5	0.8	1.1	V	
Input High Threshold Voltage	V <sub>t+</sub>	1.6	2.0	2.4	V	
Hysteresis	V <sub>TH</sub>	0.5	1.2		V	V <sub>CC</sub> =3.3V
Output Low Voltage	V <sub>OL</sub>			0.4	V	I <sub>OL</sub> = 24 mA
Input High Leakage	I <sub>LIH</sub>			+10	μA	V <sub>IN</sub> = 3.3V
Input Low Leakage	I <sub>LIL</sub>			-10	μA	V <sub>IN</sub> = 0V
<b>I/OD<sub>12cs</sub> – CMOS–level, Schmitt-trigger, bi-directional pin and open-drain output with 12mA sink capability</b>						
Input Low Threshold Voltage	V <sub>t-</sub>	0.5	0.8	1.1	V	V <sub>CC</sub> = 3.3 V
Input High Threshold Voltage	V <sub>t+</sub>	1.6	2.0	2.4	V	V <sub>CC</sub> = 3.3 V
Hysteresis	V <sub>TH</sub>	0.5	1.2		V	V <sub>CC</sub> = 3.3 V
Output Low Voltage	V <sub>OL</sub>			0.4	V	I <sub>OL</sub> = 12 mA
Input High Leakage	I <sub>LIH</sub>			+10	μA	V <sub>IN</sub> = 3.3 V
Input Low Leakage	I <sub>LIL</sub>			-10	μA	V <sub>IN</sub> = 0 V
<b>I/OD<sub>16cs</sub> – CMOS–level, Schmitt-trigger, bi-directional pin and open-drain output with 16mA sink capability</b>						
Input Low Threshold Voltage	V <sub>t-</sub>	0.5	0.8	1.1	V	V <sub>CC</sub> = 3.3 V
Input High Threshold Voltage	V <sub>t+</sub>	1.6	2.0	2.4	V	V <sub>CC</sub> = 3.3 V
Hysteresis	V <sub>TH</sub>	0.5	1.2		V	V <sub>CC</sub> = 3.3 V
Output Low Voltage	V <sub>OL</sub>			0.4	V	I <sub>OL</sub> = 16 mA
Input High Leakage	I <sub>LIH</sub>			+10	μA	V <sub>IN</sub> = 3.3 V
Input Low Leakage	I <sub>LIL</sub>			-10	μA	V <sub>IN</sub> = 0 V



## DC CHARACTERISTICS, continued

PARAMETER	SYM	MIN	TYP	MAX.	UNIT	CONDITIONS
<b>I/OD<sub>12csd</sub> – CMOS–level, Schmitt-trigger, bi-directional pin with internal pulled-down resistor and open-drain output with 12mA sink capability</b>						
Input Low Threshold Voltage	V <sub>t-</sub>	0.5	0.8	1.1	V	V <sub>CC</sub> = 3.3 V
Input High Threshold Voltage	V <sub>t+</sub>	1.6	2.0	2.4	V	V <sub>CC</sub> = 3.3 V
Hysteresis	V <sub>TH</sub>	0.5	1.2		V	V <sub>CC</sub> = 3.3 V
Output Low Voltage	V <sub>OL</sub>			0.4	V	I <sub>OL</sub> = 12 mA
Input High Leakage	I <sub>LIH</sub>			+10	μA	V <sub>IN</sub> = 3.3 V
Input Low Leakage	I <sub>LIL</sub>			-10	μA	V <sub>IN</sub> = 0 V
<b>I/OD<sub>12csu</sub> – CMOS–level, Schmitt-trigger, bi-directional pin with internal pulled-up resistor and open-drain output with 12mA sink capability</b>						
Input Low Threshold Voltage	V <sub>t-</sub>	0.5	0.8	1.1	V	V <sub>CC</sub> = 3.3 V
Input High Threshold Voltage	V <sub>t+</sub>	1.6	2.0	2.4	V	V <sub>CC</sub> = 3.3 V
Hysteresis	V <sub>TH</sub>	0.5	1.2		V	V <sub>CC</sub> = 3.3 V
Output Low Voltage	V <sub>OL</sub>			0.4	V	I <sub>OL</sub> = 12 mA
Input High Leakage	I <sub>LIH</sub>			+10	μA	V <sub>IN</sub> = 3.3 V
Input Low Leakage	I <sub>LIL</sub>			-10	μA	V <sub>IN</sub> = 0 V
<b>O4 - Output pin with 4mA source-sink capability</b>						
Output Low Voltage	V <sub>OL</sub>			0.4	V	I <sub>OL</sub> = 4 mA
Output High Voltage	V <sub>OH</sub>	2.4			V	I <sub>OH</sub> = -4 mA
<b>O8 – Output pin with 8mA source-sink capability</b>						
Output Low Voltage	V <sub>OL</sub>			0.4	V	I <sub>OL</sub> = 8 mA
Output High Voltage	V <sub>OH</sub>	2.4			V	I <sub>OH</sub> = -8 mA
<b>O12 – Output pin with 12mA source-sink capability</b>						
Output Low Voltage	V <sub>OL</sub>			0.4	V	I <sub>OL</sub> = 12 mA
Output High Voltage	V <sub>OH</sub>	2.4			V	I <sub>OH</sub> = -12 mA
<b>O16 – Output pin with 16mA source-sink capability</b>						
Output Low Voltage	V <sub>OL</sub>			0.4	V	I <sub>OL</sub> = 16 mA
Output High Voltage	V <sub>OH</sub>	2.4			V	I <sub>OH</sub> = -16 mA
<b>O24 – Output pin with 24mA source-sink capability</b>						
Output Low Voltage	V <sub>OL</sub>			0.4	V	I <sub>OL</sub> = 24 mA
Output High Voltage	V <sub>OH</sub>	2.4			V	I <sub>OH</sub> = -24 mA





## DC CHARACTERISTICS, continued

PARAMETER	SYM	MIN	TYP	MAX.	UNIT	CONDITIONS
<b>O<sub>12p3</sub> – 3.3V output pin with 12mA source-sink capability</b>						
Output Low Voltage	V <sub>OL</sub>			0.4	V	I <sub>OL</sub> = 12 mA
Output High Voltage	V <sub>OH</sub>	2.4			V	I <sub>OH</sub> = -12 mA
<b>O<sub>24p3</sub> – 3.3V output pin with 24mA source-sink capability</b>						
Output Low Voltage	V <sub>OL</sub>			0.4	V	I <sub>OL</sub> = 24 mA
Output High Voltage	V <sub>OH</sub>	2.4			V	I <sub>OH</sub> = -24 mA
<b>OD<sub>12</sub> – Open-drain output pin with 12mA sink capability</b>						
Output Low Voltage	V <sub>OL</sub>			0.4	V	I <sub>OL</sub> = 12 mA
<b>OD<sub>24</sub> – Open-drain output pin with 24mA sink capability</b>						
Output Low Voltage	V <sub>OL</sub>			0.4	V	I <sub>OL</sub> = 24 mA
<b>OD<sub>12p3</sub> – 3.3V open-drain output pin with 12mA sink capability</b>						
Output Low Voltage	V <sub>OL</sub>			0.4	V	I <sub>OL</sub> = 12 mA
<b>IN<sub>t</sub> – TTL-level input pin</b>						
Input Low Voltage	V <sub>IL</sub>			0.8	V	
Input High Voltage	V <sub>IH</sub>	2.0			V	
Input High Leakage	I <sub>LIH</sub>			+10	μA	V <sub>IN</sub> = 3.3 V
Input Low Leakage	I <sub>LIL</sub>			-10	μA	V <sub>IN</sub> = 0 V
<b>IN<sub>tp3</sub> – 3.3V TTL-level input pin</b>						
Input Low Voltage	V <sub>IL</sub>			0.8	V	
Input High Voltage	V <sub>IH</sub>	2.0			V	
Input High Leakage	I <sub>LIH</sub>			+10	μA	V <sub>IN</sub> = 3.3V
Input Low Leakage	I <sub>LIL</sub>			-10	μA	V <sub>IN</sub> = 0 V
<b>IN<sub>td</sub> – TTL-level input pin with internal pulled-down resistor</b>						
Input Low Voltage	V <sub>IL</sub>			0.8	V	
Input High Voltage	V <sub>IH</sub>	2.0			V	
Input High Leakage	I <sub>LIH</sub>			+10	μA	V <sub>IN</sub> = 3.3 V
Input Low Leakage	I <sub>LIL</sub>			-10	μA	V <sub>IN</sub> = 0 V



## DC CHARACTERISTICS, continued

PARAMETER	SYM	MIN	TYP	MAX.	UNIT	CONDITIONS
<b>IN<sub>tu</sub> – TTL-level input pin with internal pulled-up resistor</b>						
Input Low Voltage	V <sub>IL</sub>			0.8	V	
Input High Voltage	V <sub>IH</sub>	2.0			V	
Input High Leakage	I <sub>LIH</sub>			+10	μA	V <sub>IN</sub> = 3.3 V
Input Low Leakage	I <sub>LIL</sub>			-10	μA	V <sub>IN</sub> = 0 V
<b>IN<sub>ts</sub> – TTL-level, Schmitt-trigger input pin</b>						
Input Low Threshold Voltage	V <sub>t-</sub>	0.5	0.8	1.1	V	V <sub>CC</sub> = 3.3 V
Input High Threshold Voltage	V <sub>t+</sub>	1.6	2.0	2.4	V	V <sub>CC</sub> = 3.3 V
Hysteresis	V <sub>TH</sub>	0.5	1.2		V	V <sub>CC</sub> = 3.3 V
Input High Leakage	I <sub>LIH</sub>			+10	μA	V <sub>IN</sub> = 3.3 V
Input Low Leakage	I <sub>LIL</sub>			-10	μA	V <sub>IN</sub> = 0 V
<b>IN<sub>tsp3</sub> – 3.3 V TTL-level, Schmitt-trigger input pin</b>						
Input Low Threshold Voltage	V <sub>t-</sub>	0.5	0.8	1.1	V	V <sub>CC</sub> = 3.3 V
Input High Threshold Voltage	V <sub>t+</sub>	1.6	2.0	2.4	V	V <sub>CC</sub> = 3.3 V
Hysteresis	V <sub>TH</sub>	0.5	1.2		V	V <sub>CC</sub> = 3.3 V
Input High Leakage	I <sub>LIH</sub>			+10	μA	V <sub>IN</sub> = 3.3 V
Input Low Leakage	I <sub>LIL</sub>			-10	μA	V <sub>IN</sub> = 0 V
<b>IN<sub>c</sub> – CMOS-level input pin</b>						
Input Low Voltage	V <sub>IL</sub>			0.3 V <sub>CC</sub>	V	
Input High Voltage	V <sub>IH</sub>	0.7 V <sub>CC</sub>			V	
Input High Leakage	I <sub>LIH</sub>			+10	μA	V <sub>IN</sub> = V <sub>CC</sub> = 3.3V
Input Low Leakage	I <sub>LIL</sub>			-10	μA	V <sub>IN</sub> = 0 V
<b>IN<sub>cd</sub> – CMOS-level input pin with internal pulled-down resistor</b>						
Input Low Voltage	V <sub>IL</sub>			0.3 V <sub>CC</sub>	V	
Input High Voltage	V <sub>IH</sub>	0.7 V <sub>CC</sub>			V	
Input High Leakage	I <sub>LIH</sub>			+10	μA	V <sub>IN</sub> = V <sub>CC</sub> = 3.3V
Input Low Leakage	I <sub>LIL</sub>			-10	μA	V <sub>IN</sub> = 0 V
Input Low Voltage	V <sub>IL</sub>			0.3 V <sub>CC</sub>	V	



DC CHARACTERISTICS, continued

PARAMETER	SYM	MIN	TYP	MAX.	UNIT	CONDITIONS
<b>IN<sub>cu</sub> – CMOS-level input pin with internal pulled-up resistor</b>						
Input High Voltage	V <sub>IH</sub>	0.7 V <sub>CC</sub>			V	
Input High Leakage	I <sub>LIH</sub>			+10	μA	V <sub>IN</sub> = V <sub>CC</sub> = 3.3V
Input Low Leakage	I <sub>LIL</sub>			-10	μA	V <sub>IN</sub> = 0 V
<b>IN<sub>cs</sub> – CMOS-level, Schmitt-trigger input pin</b>						
Input Low Threshold Voltage	V <sub>t-</sub>	1.3	1.5	1.7	V	V <sub>CC</sub> = 3.3V
Hysteresis	V <sub>TH</sub>	1.5	2		V	V <sub>CC</sub> = 3.3V
Input High Leakage	I <sub>LIH</sub>			+10	μA	V <sub>IN</sub> = 3.3V
Input Low Leakage	I <sub>LIL</sub>			-10	μA	V <sub>IN</sub> = 0 V
<b>IN<sub>csu</sub> – CMOS-level, Schmitt-trigger input pin with internal pulled-up resistor</b>						
Input Low Threshold Voltage	V <sub>t-</sub>	0.5	0.8	1.1	V	V <sub>CC</sub> = 3.3V
Input High Threshold Voltage	V <sub>t+</sub>	1.6	2.0	2.4	V	V <sub>CC</sub> = 3.3V
Hysteresis	V <sub>TH</sub>	0.5	1.2		V	V <sub>CC</sub> = 3.3V
Input High Leakage	I <sub>LIH</sub>			+10	μA	V <sub>IN</sub> = 3.3V
Input Low Leakage	I <sub>LIL</sub>			-10	μA	V <sub>IN</sub> = 0 V
<b>AOUT – Analog output</b>						
		N.A.				
<b>IN<sub>v1s</sub> – VID input pin for INTEL® VRM10.0, and VRM11 design</b>						
Input Low Voltage	V <sub>IL</sub>			0.4	V	
Input High Voltage	V <sub>IH</sub>	0.6			V	
<b>IN<sub>v2s</sub> – VID input pin for AMD™ VRM design</b>						
Input Low Voltage	V <sub>IL</sub>			0.8	V	
Input High Voltage	V <sub>IH</sub>	1.4			V	



## DC CHARACTERISTICS, continued

PARAMETER	SYM	MIN	TYP	MAX.	UNIT	CONDITIONS
<b>I/O<sub>V3</sub> – Bi-direction pin with source capability of 6 mA and sink capability of 1 mA for INTEL® PECl</b>						
Input Low Voltage	V <sub>IL</sub>	0.275V <sub>tt</sub>		0.5V <sub>tt</sub>	V	
Input High Voltage	V <sub>IH</sub>	0.55V <sub>tt</sub>		0.725V <sub>tt</sub>	V	
Output Low Voltage	V <sub>OL</sub>			0.25V <sub>tt</sub>	V	
Output High Voltage	V <sub>OH</sub>	0.75V <sub>tt</sub>			V	
Hysterisis	V <sub>Hys</sub>	0.1V <sub>tt</sub>			V	
<b>I/O<sub>V4</sub> – Bi-direction pin with source capability of 6 mA and sink capability of 1 mA for INTEL® SST</b>						
Input Low Threshold Voltage	V <sub>t-</sub>	0.4		0.65	V	V <sub>CC</sub> = 1.5 V
Input High Threshold Voltage	V <sub>t+</sub>	0.75		1.1	V	V <sub>CC</sub> = 1.5 V
Input High Leakage	I <sub>LIH</sub>			+10	μA	V <sub>IN</sub> = V <sub>CC</sub>
Input Low Leakage	I <sub>LIL</sub>			-10	μA	V <sub>IN</sub> = 0V
Hysteresis	V <sub>TH</sub>	0.15			V	V <sub>CC</sub> = 1.5 V



### 21.3 AC CHARACTERISTICS

#### 21.3.1 AC Power Failure Resume Timing

1. Logical Device A, CR[E4h] bit7 = "0" and CR[E4h] bits[6:5] are selected to "OFF" state ("OFF" means always being turned off or the previous state is off)

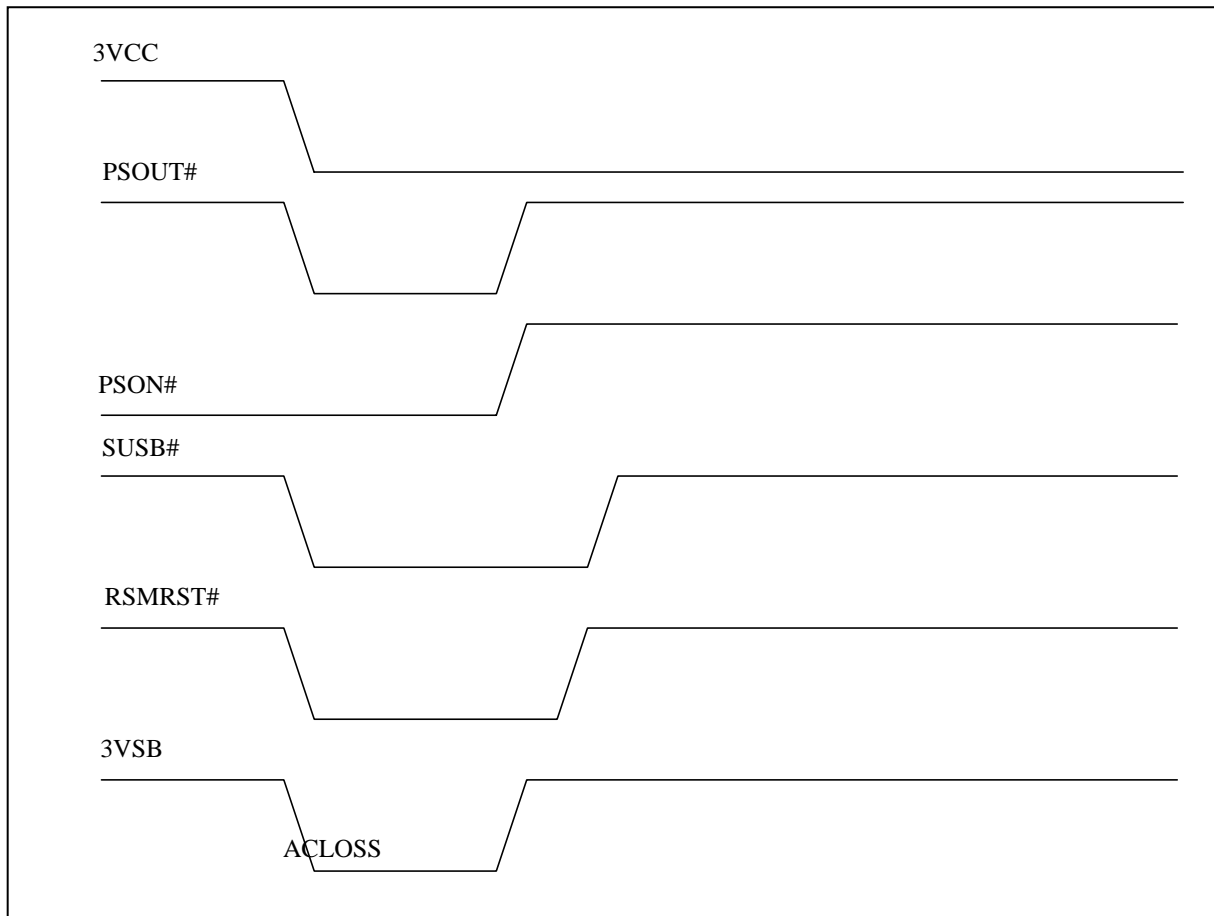



2. Logical Device A, CR[E4h] bit7 = "0" and CR[E4h] bits[6:5] are selected to "ON" state ("ON" means always being turned on or the previous state is on)

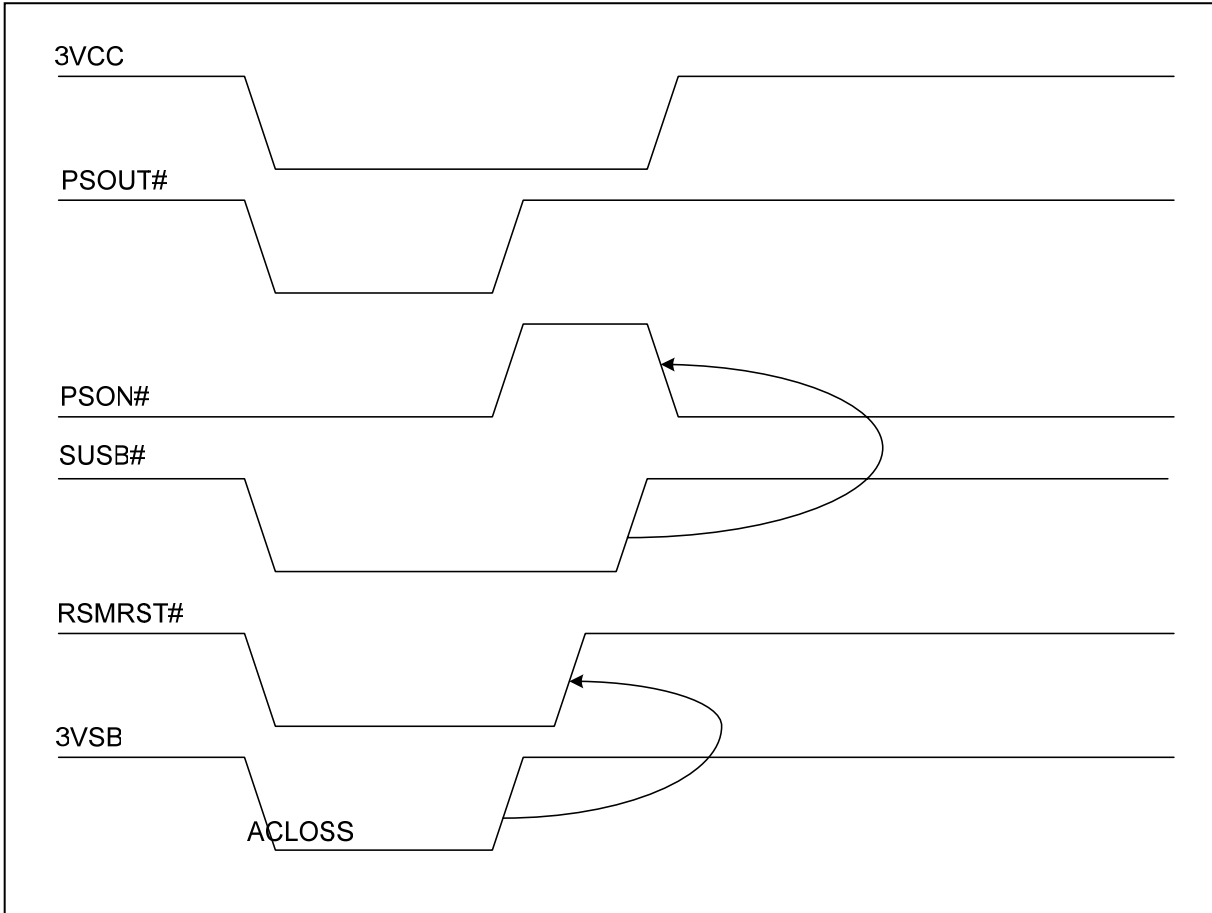



3. Logical Device A, CR[E4h] bit7 = "1" and CR[E4h] bits[6:5] are selected to "OFF" state ("OFF" means always being turned off or the previous state is off)

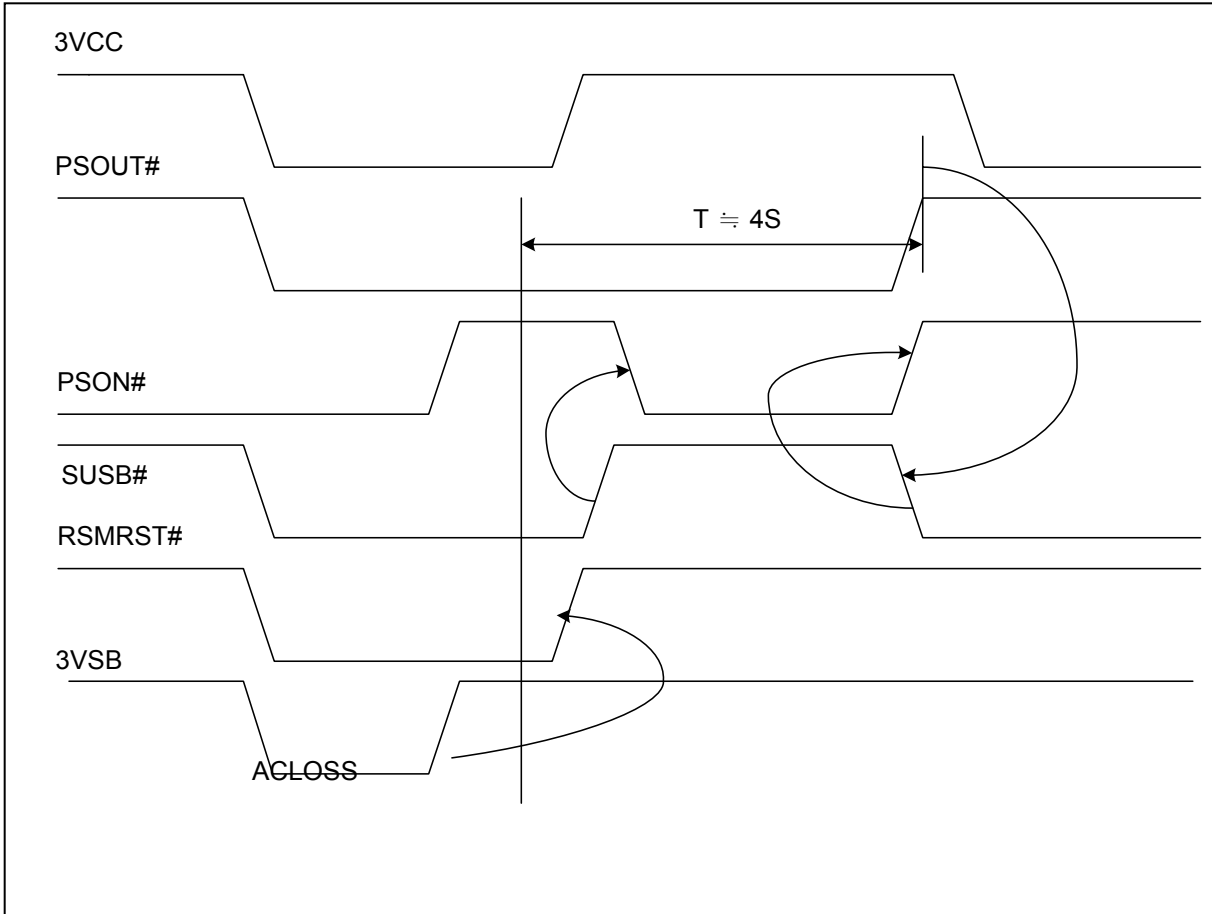



4. Logical Device A, CR[E4h] bit7 = "1" and CR[E4h] bits[6:5] are selected to "ON" state ("ON" means always being turned on or the previous state is on)

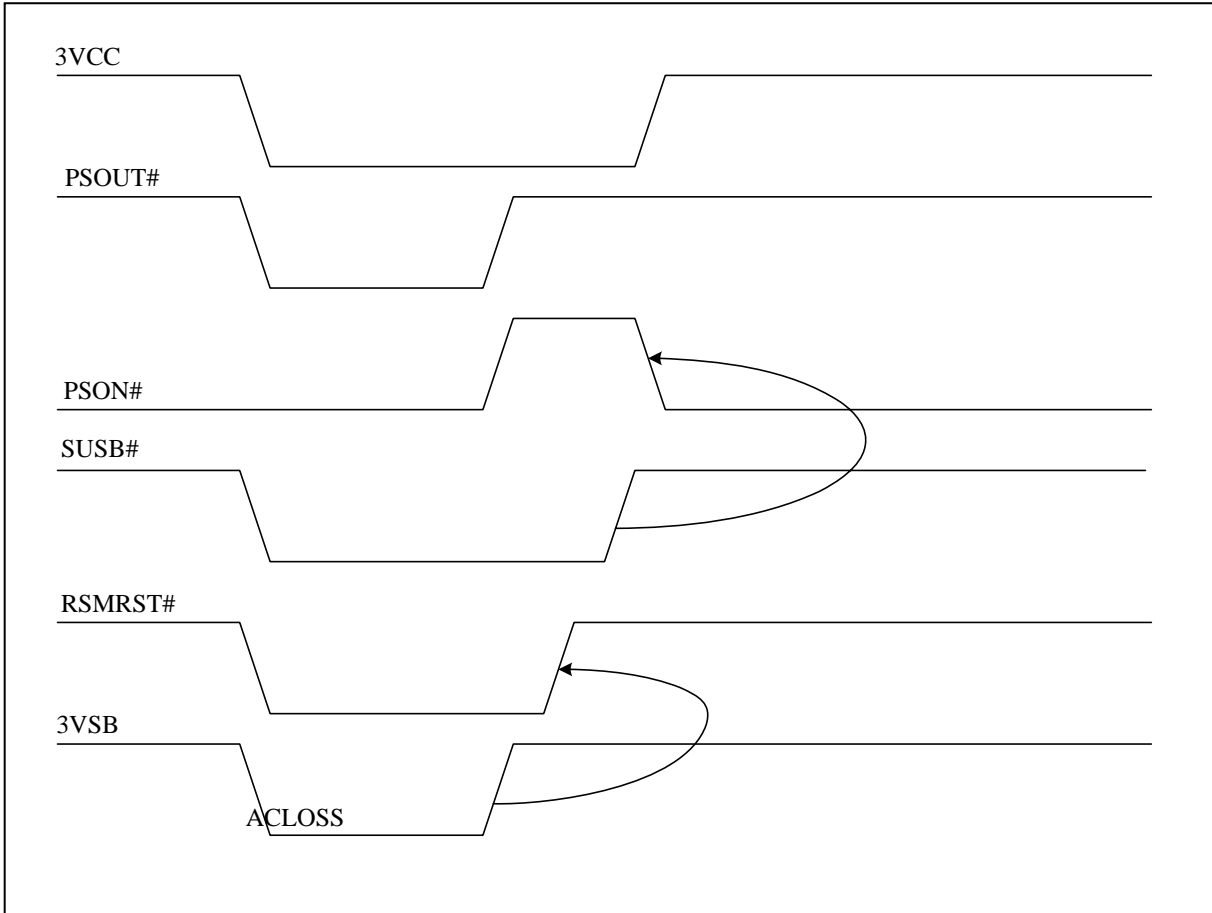





**\*\* What's the definition of former state at AC power failure?**

1) The previous state is "ON"

3VCC falls to 2.6V and SUSB# keeps at VIH 2.0V

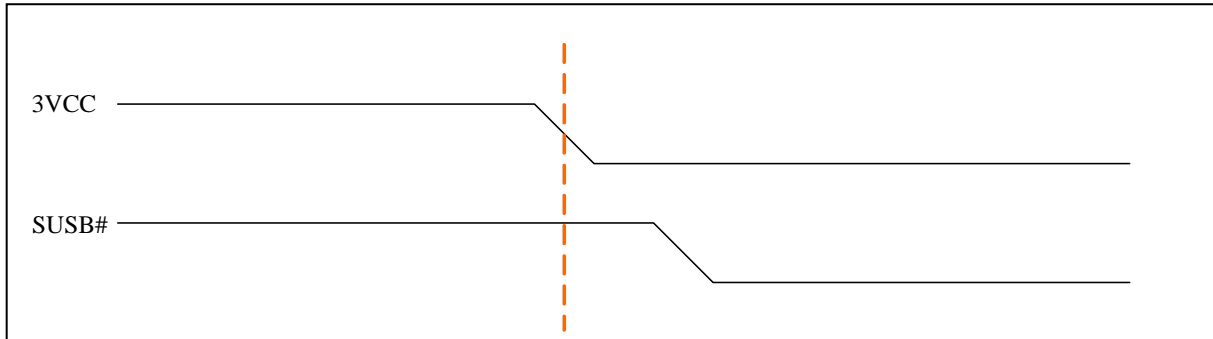

2) The previous state is "OFF"

3VCC falls to 2.6V and SUSB# keeps at VIL 0.8V

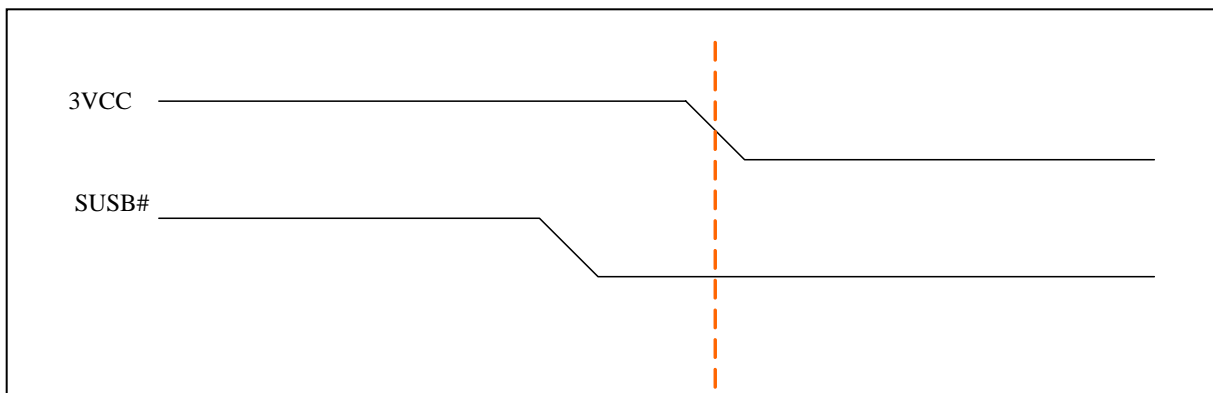

To ensure that VCC does not fall faster than VSB in various ATX Power Supplies, the W83627DHG adds the option of "user define mode" for the pre-defined state before AC power failure. BIOS can set the pre-defined state to be "On" or "Off". According to this setting, the system chooses the state after the AC power recovery.

**Logical Device A, CR E4h**

6~5	R / W	Power-loss control bits => (VBAT) 00: System always turns off when it returns from power-loss state. 01: System always turns on when it returns from power-loss state. 10: System turns off / on when it returns from power-loss state depending on the state before the power loss. 11: User defines the state before the power loss.(The previous state is set at CRE6[4])
-----	-------	--



Logical Device A, CR E6h

4	R / W	Power loss Last State Flag. (VBAT) 0: ON 1: OFF
---	-------	---

21.3.2 VSBGATE# Timing – for UBE and UBF Version Only

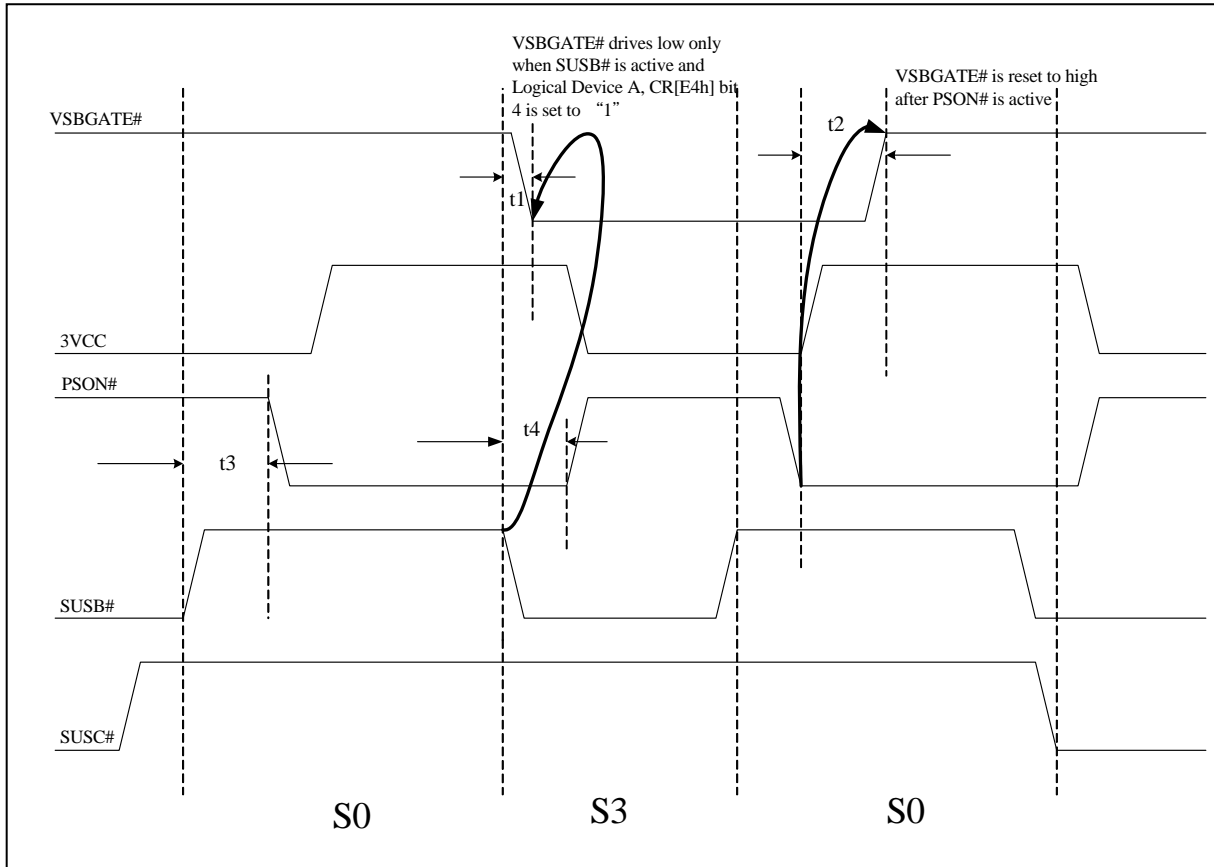

SYMBOL	PARAMETER	MIN	MAX	UNIT
t1	SUSB# active to VSBGATE# active	0	80	nS
t2	PSON# active to VSBGATE# inactive	90	142	mS
t3	SUSB# inactive to PSON# active	0	80	nS
t4	SUSB# active to PSON# inactive	28	39	mS

**Note.** The values above the worst-case results of R&D simulation



### 21.3.3 Clock Input Timing

PARAMETER	48MHZ / 24MHZ		UNIT
	MIN	MAX	
Cycle to cycle jitter		300/500	ps
Duty cycle	45	55	%

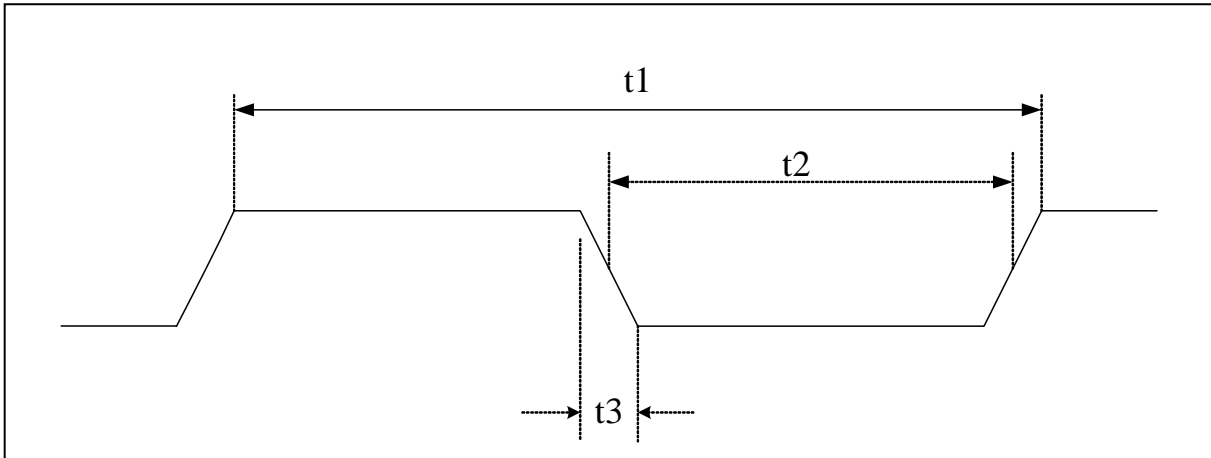

PARAMETER	DESCRIPTION	48MHZ / 24MHZ			UNIT
		MIN	TYP	MAX	
t1	Clock cycle time		20.8 / 41.7		ns
t2	Clock high time/low time	9 / 19	10 / 21		ns
t3	Clock rising time/falling time (0.4V~2.4V)			3	ns



21.3.4 PECl and SST Timing

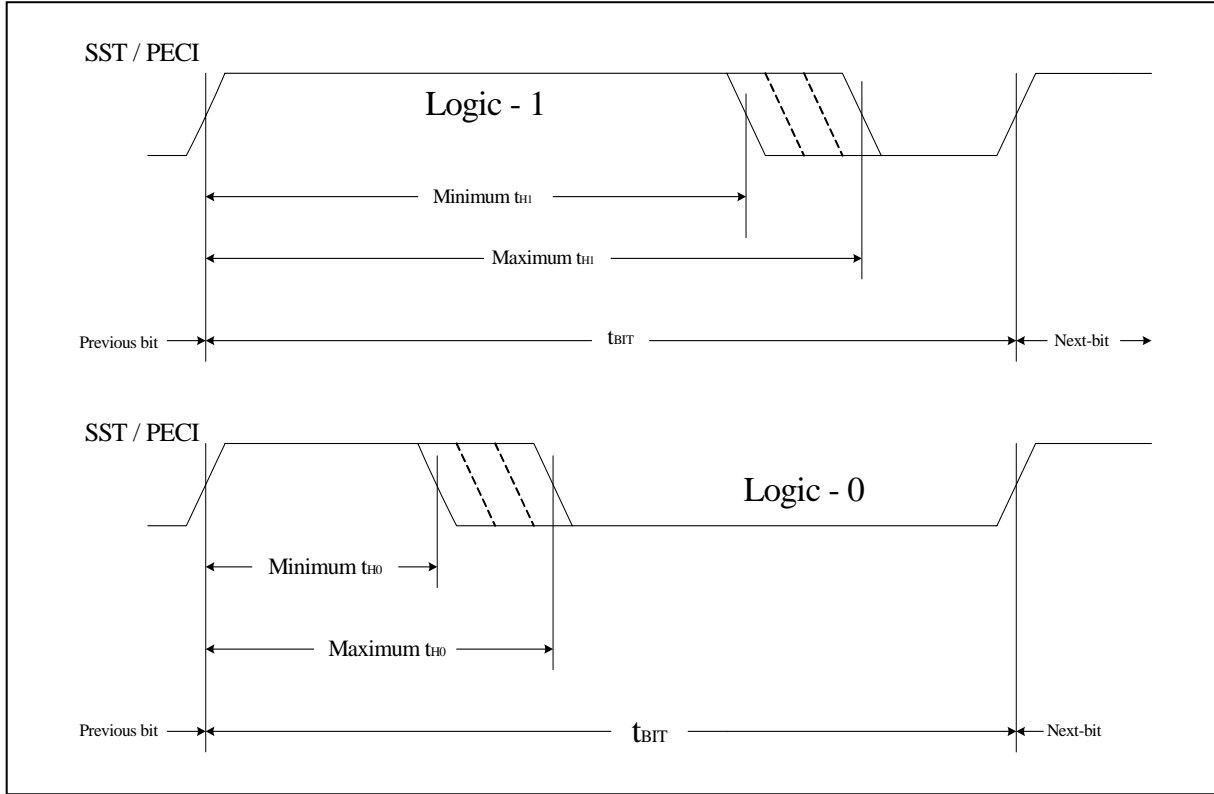

SYMBOL		MIN	TYP	MAX	UNITS
t <sub>BIT</sub>	Client	0.495		500	μs
	Originator	0.495		250	
t <sub>H1</sub>		0.6	3/4	0.8	× t <sub>BIT</sub>
t <sub>H0</sub>		0.2	1/4	0.4	× t <sub>BIT</sub>



## 21.3.5 SPI Timing

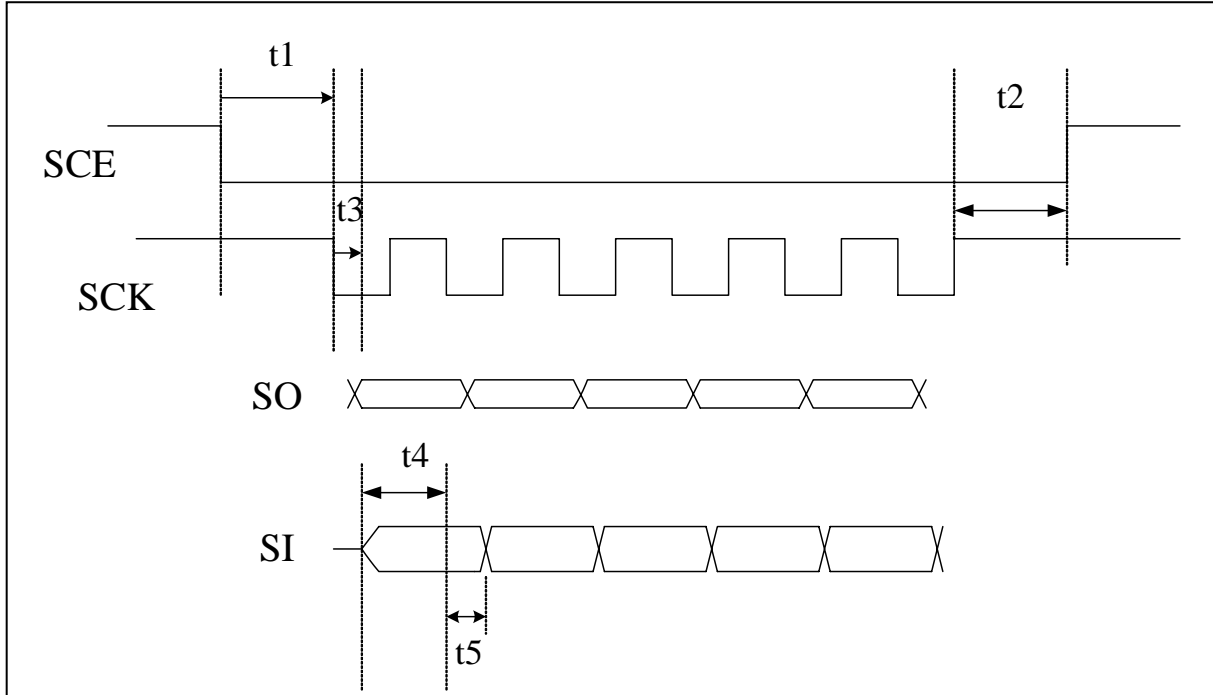

DESCRIPTION	SYMBOL	MIN	TYP	MAX
Enable to first clock falling	$t_1$	25ns	-	35ns
Disable after last clock rising	$t_2$	40ns	-	50ns
Output hold time	$t_3$	-	-	5ns
Input setup time	$t_4$	5ns	-	-
Input hold time	$t_5$	6ns	-	-



### 21.3.6 SMBus Timing

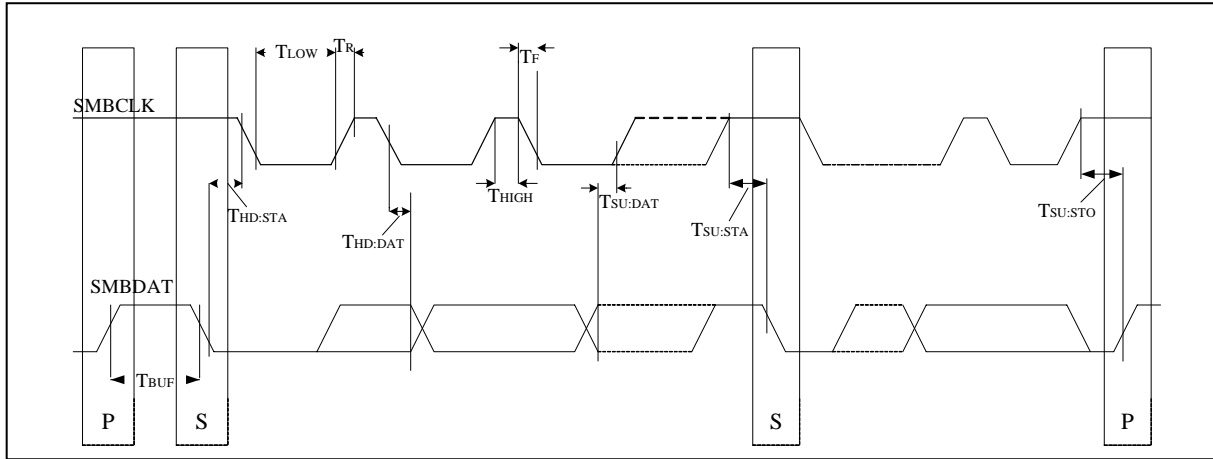

SYMBOL	PARAMETER	MIN.	MAX.:	UNITS
$T_{BUF}$	Bus Free Time between Stop and Start Condition	4.7	-	$\mu$ S
$T_{HD:STA}$	Hold time after (Repeated) Start Condition. After this period, the first clock is generated	4.0	-	$\mu$ S
$T_{SU:STA}$	Repeated Start Condition setup time	4.7	-	$\mu$ S
$T_{SU:STO}$	Stop Condition setup time	4.0	-	$\mu$ S
$T_{HD:DAT}$	Data hold time	300	-	nS
$T_{SU:DAT}$	Data setup time	250	-	nS
$T_{LOW}$	Clock low period	4.7	-	$\mu$ S
$T_{HIGH}$	Clock high period	4.0	50	$\mu$ S
$T_F$	Clock/Data Falling Time	-	300	nS
$T_R$	Clock/Data Rising Time	-	1000	nS



### 21.3.7 Floppy Disk Drive Timing

FDC: Data rate = 1MB, 500KB, 300KB, 250KB/sec.

PARAMETER	SYM.	MIN.	TYP. (NOTE 1)	MAX.	UNIT
DIR# setup time to STEP#	TDST	1.0/1.6 /2.0/4.0			μS
DIR# hold time from STEP#	TSTD	24/40 /48/96			μS
STEP# pulse width	TSTP	6.8/11.5 /13.8/27.8	7/11.7 /14/28	7.2/11.9 /14.2/28.2	μS
STEP# cycle width	TSC	NOTE 2	NOTE 2	NOTE 2	mS
INDEX# pulse width	TIDX	125/250 /417/500			nS
RDATA# pulse width	TRD	40			nS
WD# pulse width	TWD	100/185 /225/475	125/210 /250/500	150/235 /275/525	nS

**Notes:**

1. Typical values for T = 25°C and normal supply voltage.
2. Programmable from 0.5 mS through 32 mS as described in step rate table.  
(Please refer to the description of the SPECIFY command set.)

Step Rate Table

DATA RATE SRT	1MB/S	500KB/S	300KB/S	250KB/S
0	8	16	26.7	32
1	7.5	15	25	30
...	...	...	...	...
E	1.0	2	3.33	4
F	0.5	1	1.67	2

Floppy Disk Driving Timing

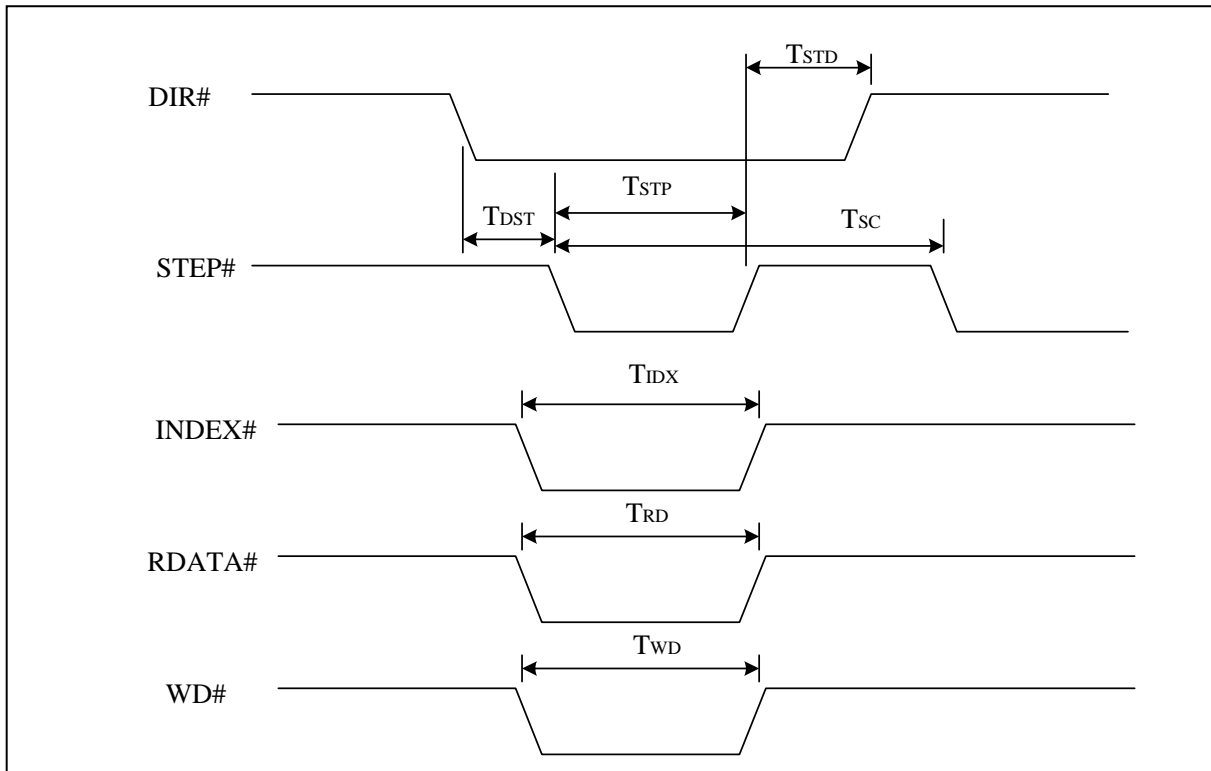

### 21.3.8 UART/Parallel Port

PARAMETER	SYMBOL	TEST CONDITIONS	MIN.	MAX.	UNIT
Delay from Stop to Set Interrupt	T <sub>SINT</sub>		9/16		Baud Rate
Delay from $\overline{\text{IOR}}$ Reset Interrupt	T <sub>RINT</sub>		9	1000	nS
Delay from Initial IRQ Reset to Transmit Start	T <sub>IRS</sub>		1/16	8/16	Baud Rate
Delay from to Reset interrupt	T <sub>HR</sub>			175	nS
Delay from Initial $\overline{\text{IOW}}$ to interrupt	T <sub>SI</sub>		9/16	16/16	Baud Rate
Delay from Stop to Set Interrupt	T <sub>STI</sub>			8/16	Baud Rate
Delay from $\overline{\text{IOR}}$ to Reset Interrupt	T <sub>IR</sub>		8	250	nS
Delay from $\overline{\text{IOR}}$ to Output	T <sub>MWO</sub>		6	200	nS
Set Interrupt Delay from Modem Input	T <sub>SIM</sub>		18	250	nS
Reset Interrupt Delay from $\overline{\text{IOR}}$	T <sub>TRIM</sub>		9	250	nS
Baud Divisor	N	100 pF Loading		2 <sup>16</sup> -1	



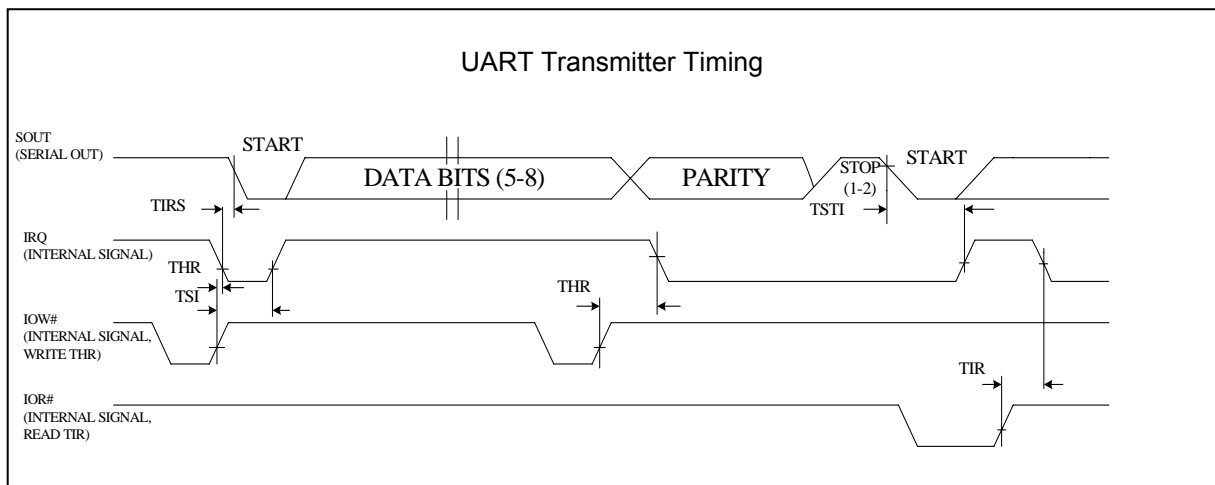
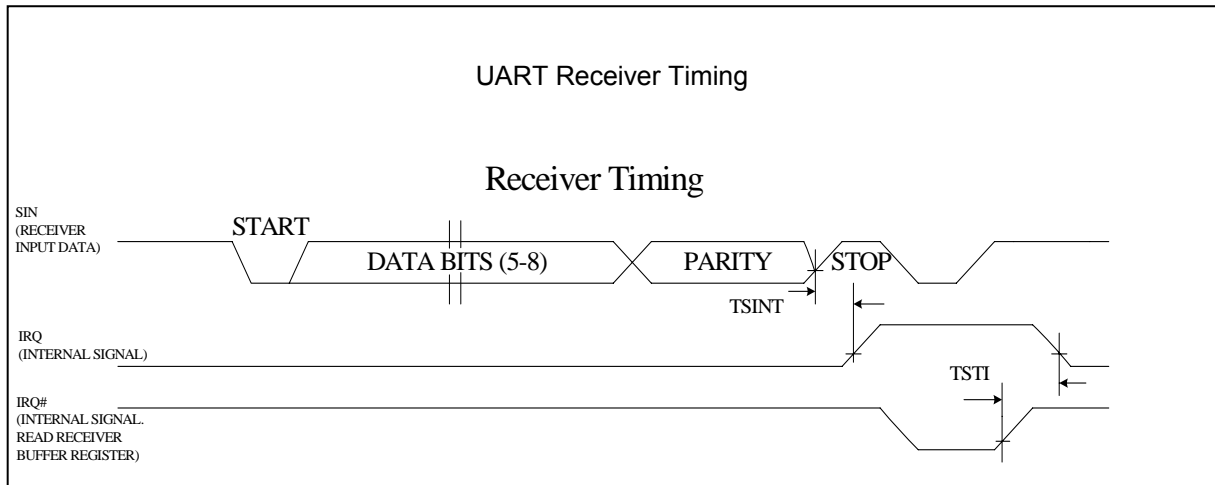



21.3.8.1. Modem Control Timing

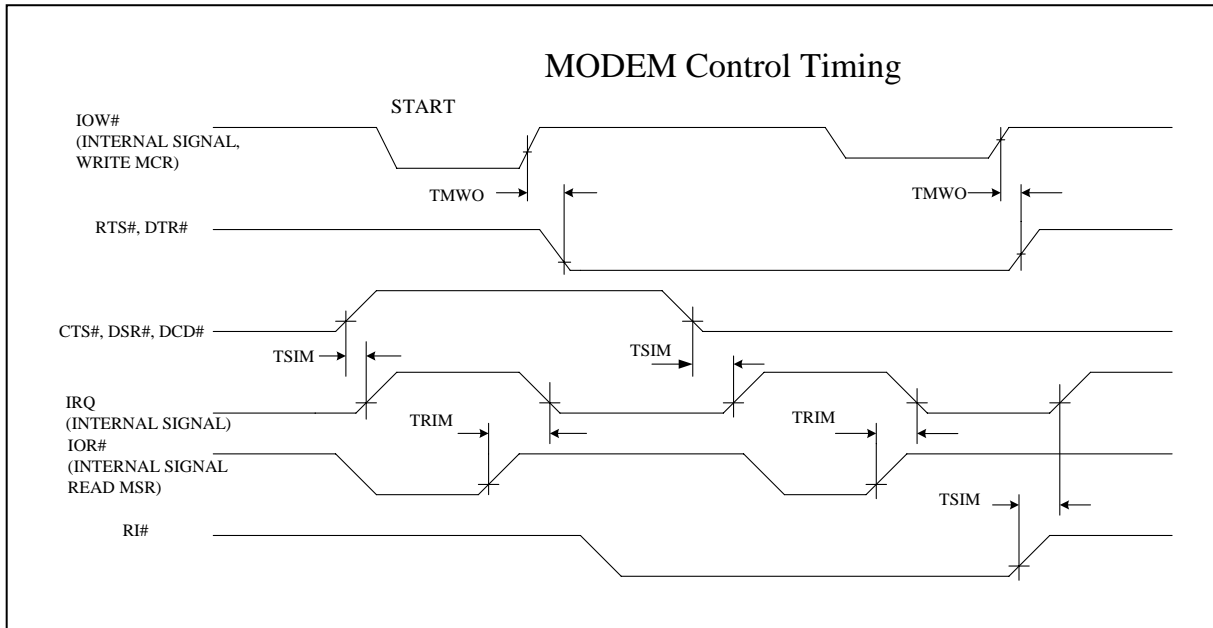

21.3.9 Parallel Port Mode Parameters

PARAMETER	SYM.	MIN.	TYP.	MAX.	UNIT
PD0-7, INDEX, STROBE, AUTOFD Delay from IOW	t1			100	nS
IRQ Delay from ACK, nFAULT	t2			60	nS
IRQ Delay from IOW	t3			105	nS
IRQ Active Low in ECP and EPP Modes	t4	200		300	nS
ERROR Active to IRQ Active	t5			105	nS
PD0-7, INDEX, STROBE, AUTOFD Delay from IOW	t1			100	nS
IRQ Delay from ACK, nFAULT	t2			60	nS
IRQ Delay from IOW	t3			105	nS
IRQ Active Low in ECP and EPP Modes	t4	200		300	nS
ERROR Active to IRQ Active	t5			105	nS



21.3.10 Parallel Port

21.3.10.1. Parallel Port Timing

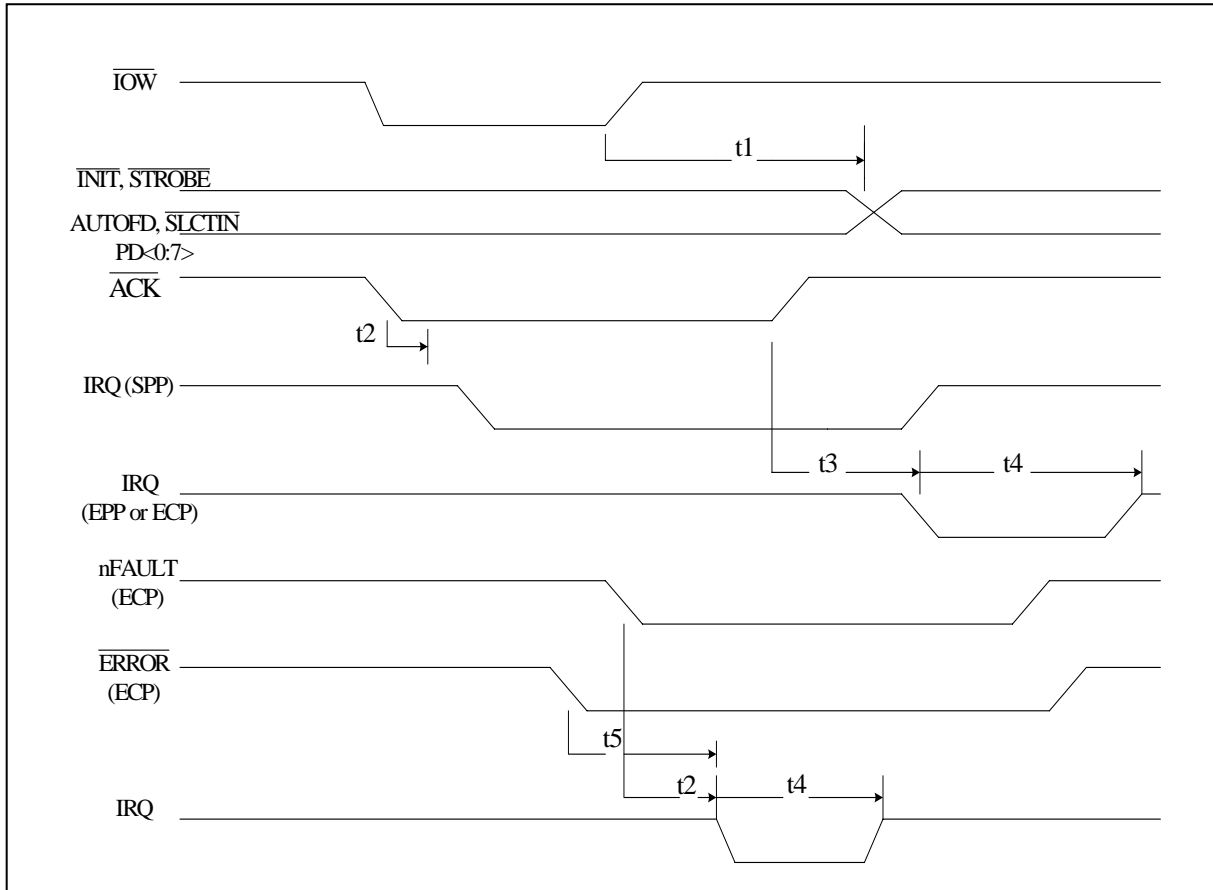

21.3.10.2. EPP Data or Address Read Cycle Timing Parameters

PARAMETER	SYM.	MIN.	MAX.	UNIT
$\overline{WAIT}$ Asserted to $\overline{WRITE}$ Deasserted	t14	0	185	nS
Deasserted to $\overline{WRITE}$ Modified	t15	60	190	nS
$\overline{WAIT}$ Asserted to PD Hi-Z	t17	60	180	nS
Command Asserted to PD Valid	t18	0		nS
Command Deasserted to PD Hi-Z	t19	0		nS
$\overline{WAIT}$ Deasserted to PD Drive	t20	60	190	nS
$\overline{WRITE}$ Deasserted to Command	t21	1		nS
PBDIR Set to Command	t22	0	20	nS



EPP Data or Address Read Cycle Timing Parameters, continued

PARAMETER	SYM.	MIN.	MAX.	UNIT
PD Hi-Z to Command Asserted	t23	0	30	nS
Asserted to Command Asserted	t24	0	195	nS
$\overline{\text{WAIT}}$ Deasserted to Command Deasserted	t25	60	180	nS
Time out	t26	10	12	nS
PD Valid to $\overline{\text{WAIT}}$ Deasserted	t27	0		nS
PD Hi-Z to $\overline{\text{WAIT}}$ Deasserted	t28	0		$\mu\text{S}$
Ax Valid to $\overline{\text{IOR}}$ Asserted	t1	40		nS
IOCHRDY Deasserted to $\overline{\text{IOR}}$ Deasserted	t2	0		nS
$\overline{\text{IOR}}$ Deasserted to Ax Valid	t3	10	10	nS
$\overline{\text{IOR}}$ Deasserted to $\overline{\text{IOW}}$ or $\overline{\text{IOR}}$ Asserted	t4	40		
$\overline{\text{IOR}}$ Asserted to IOCHRDY Asserted	t5	0	24	nS
PD Valid to SD Valid	t6	0	75	nS
$\overline{\text{IOR}}$ Deasserted to SD Hi-Z (Hold Time)	t7	0	40	$\mu\text{S}$
SD Valid to IOCHRDY Deasserted	t8	0	85	nS
$\overline{\text{WAIT}}$ Deasserted to IOCHRDY Deasserted	t9	60	160	nS
PD Hi-Z to PDBIR Set	t10	0		nS
$\overline{\text{WRITE}}$ Deasserted to $\overline{\text{IOR}}$ Asserted	t13	0		nS
$\overline{\text{WAIT}}$ Asserted to $\overline{\text{WRITE}}$ Deasserted	t14	0	185	nS
Deasserted to $\overline{\text{WRITE}}$ Modified	t15	60	190	nS
$\overline{\text{IOR}}$ Asserted to PD Hi-Z	t16	0	50	nS
$\overline{\text{WAIT}}$ Asserted to PD Hi-Z	t17	60	180	nS
Command Asserted to PD Valid	t18	0		nS
Command Deasserted to PD Hi-Z	t19	0		nS
$\overline{\text{WAIT}}$ Deasserted to PD Drive	t20	60	190	nS
$\overline{\text{WRITE}}$ Deasserted to Command	t21	1		nS
PBDIR Set to Command	t22	0	20	nS
PD Hi-Z to Command Asserted	t23	0	30	nS
Asserted to Command Asserted	t24	0	195	nS



EPP Data or Address Read Cycle Timing Parameters, continued

PARAMETER	SYM.	MIN.	MAX.	UNIT
$\overline{\text{WAIT}}$ Deasserted to Command Deasserted	t25	60	180	nS
Time out	t26	10	12	nS
PD Valid to $\overline{\text{WAIT}}$ Deasserted	t27	0		nS
PD Hi-Z to $\overline{\text{WAIT}}$ Deasserted	t28	0		$\mu\text{S}$

21.3.10.3. EPP Data or Address Read Cycle (EPP Version 1.9)

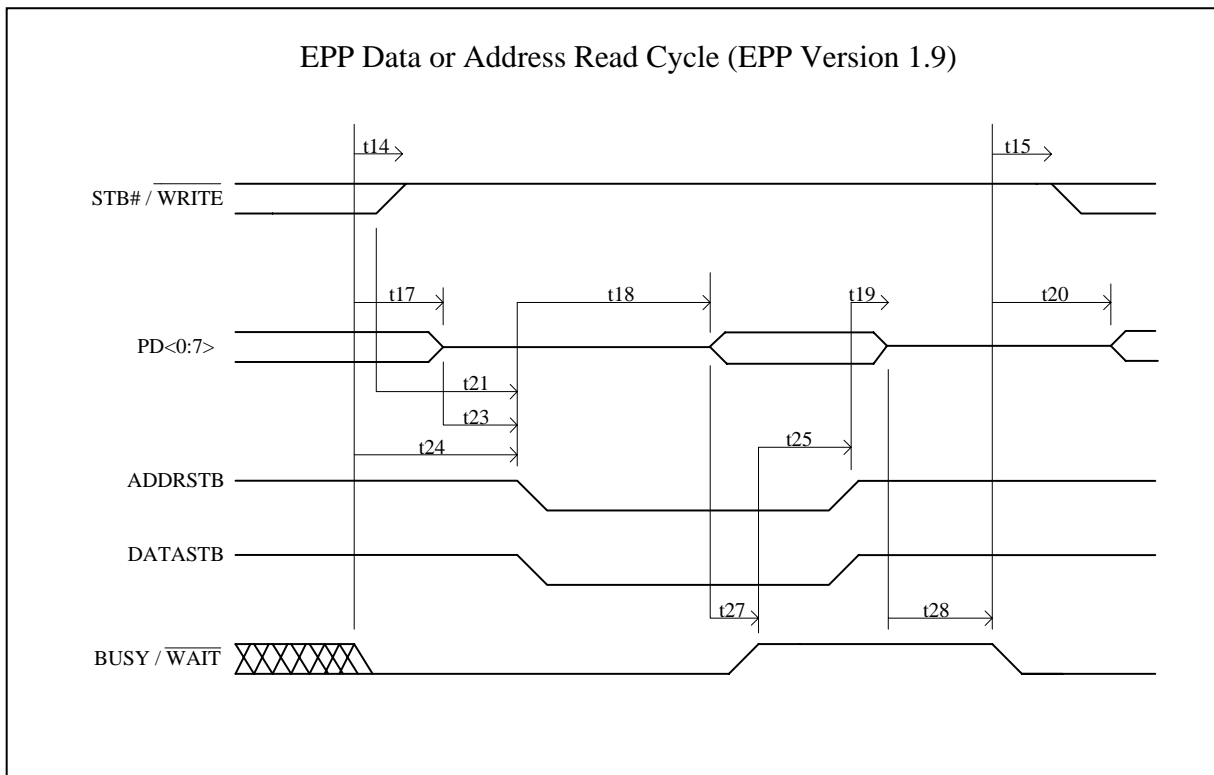



21.3.10.4. EPP Data or Address Read Cycle (EPP Version 1.7)

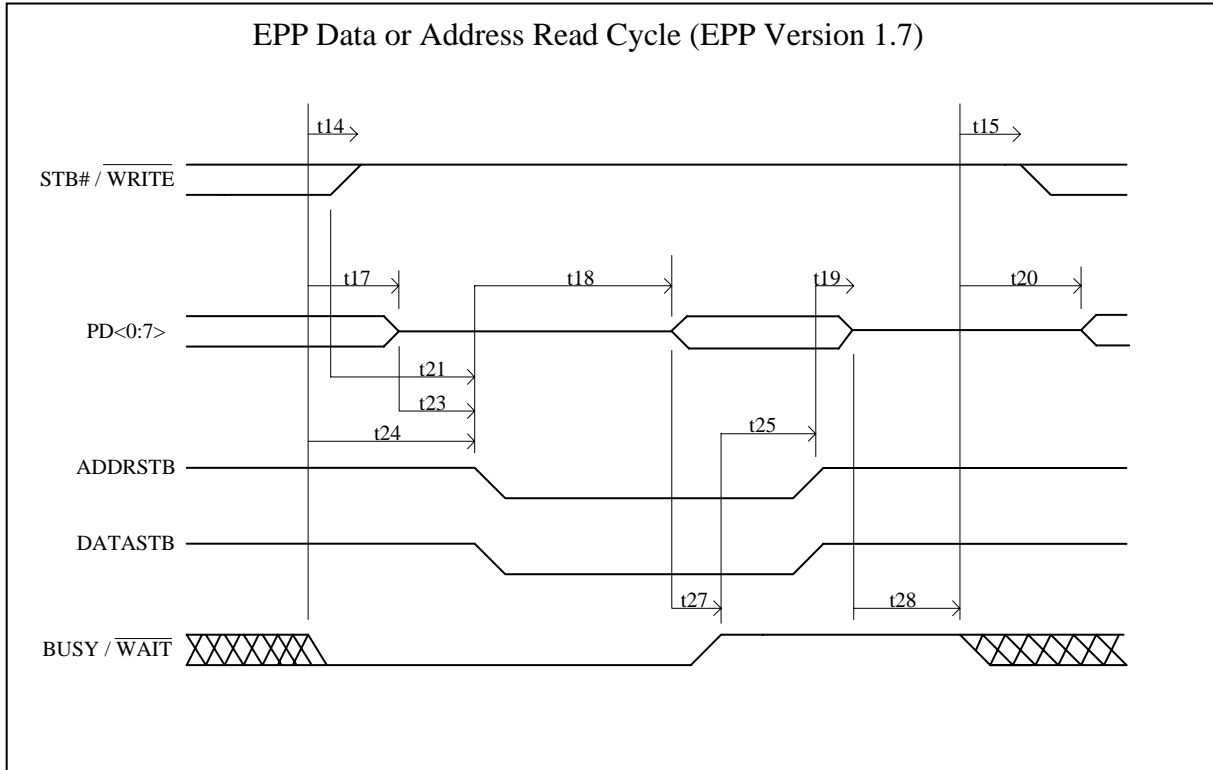



### 21.3.10.5. EPP Data or Address Write Cycle Timing Parameters

PARAMETER	SYM.	MIN.	MAX.	UNIT
PBDIR Low to $\overline{\text{WRITE}}$ Asserted	t10	0		nS
$\overline{\text{WAIT}}$ Asserted to $\overline{\text{WRITE}}$ Asserted	t11	60	185	nS
$\overline{\text{WAIT}}$ Asserted to $\overline{\text{WRITE}}$ Change	t12	60	185	nS
$\overline{\text{WAIT}}$ Asserted to PD Invalid	t14	0		nS
PD Invalid to Command Asserted	t15	10		nS
$\overline{\text{WAIT}}$ Asserted to Command Asserted	t17	60	210	nS
$\overline{\text{WAIT}}$ Deasserted to Command Deasserted	t18	60	190	nS
Command Asserted to $\overline{\text{WAIT}}$ Deasserted	t19	0	10	$\mu\text{S}$
Time out	t20	10	12	$\mu\text{S}$
Command Deasserted to $\overline{\text{WAIT}}$ Asserted	t21	0		nS
Ax Valid to $\overline{\text{IOW}}$ Asserted	t1	40		nS
SD Valid to $\overline{\text{IOW}}$ Asserted	t2	10		nS
$\overline{\text{IOW}}$ Deasserted to Ax Invalid	t3	10		nS
$\overline{\text{WAIT}}$ Deasserted to IOCHRDY Deasserted	t4	0		nS
Command Asserted to $\overline{\text{WAIT}}$ Deasserted	t5	10		nS
$\overline{\text{IOW}}$ Deasserted to $\overline{\text{IOW}}$ or $\overline{\text{IOR}}$ Asserted	t6	40		nS
IOCHRDY Deasserted to $\overline{\text{IOW}}$ Deasserted	t7	0	24	nS
$\overline{\text{WAIT}}$ Asserted to Command Asserted	t8	60	160	nS
$\overline{\text{IOW}}$ Asserted to $\overline{\text{WAIT}}$ Asserted	t9	0	70	nS
PBDIR Low to $\overline{\text{WRITE}}$ Asserted	t10	0		nS
$\overline{\text{WAIT}}$ Asserted to $\overline{\text{WRITE}}$ Asserted	t11	60	185	nS
$\overline{\text{WAIT}}$ Asserted to $\overline{\text{WRITE}}$ Change	t12	60	185	nS
$\overline{\text{IOW}}$ Asserted to PD Valid	t13	0	50	nS
$\overline{\text{WAIT}}$ Asserted to PD Invalid	t14	0		nS
PD Invalid to Command Asserted	t15	10		nS
$\overline{\text{IOW}}$ to Command Asserted	t16	5	35	nS
$\overline{\text{WAIT}}$ Asserted to Command Asserted	t17	60	210	nS
$\overline{\text{WAIT}}$ Deasserted to Command Deasserted	t18	60	190	nS
Command Asserted to $\overline{\text{WAIT}}$ Deasserted	t19	0	10	$\mu\text{S}$



EPP Data or Address Write Cycle Timing Parameters, continued

PARAMETER	SYM.	MIN.	MAX.	UNIT
Time out	t20	10	12	μS
Command Deasserted to $\overline{\text{WAIT}}$ Asserted	t21	0		nS
$\overline{\text{IOW}}$ Deasserted to $\overline{\text{WRITE}}$ Deasserted and PD invalid	t22	0		nS
$\overline{\text{WRITE}}$ to Command Asserted	t16	5	35	nS

21.3.10.6. EPP Data or Address Write Cycle (EPP Version 1.9)

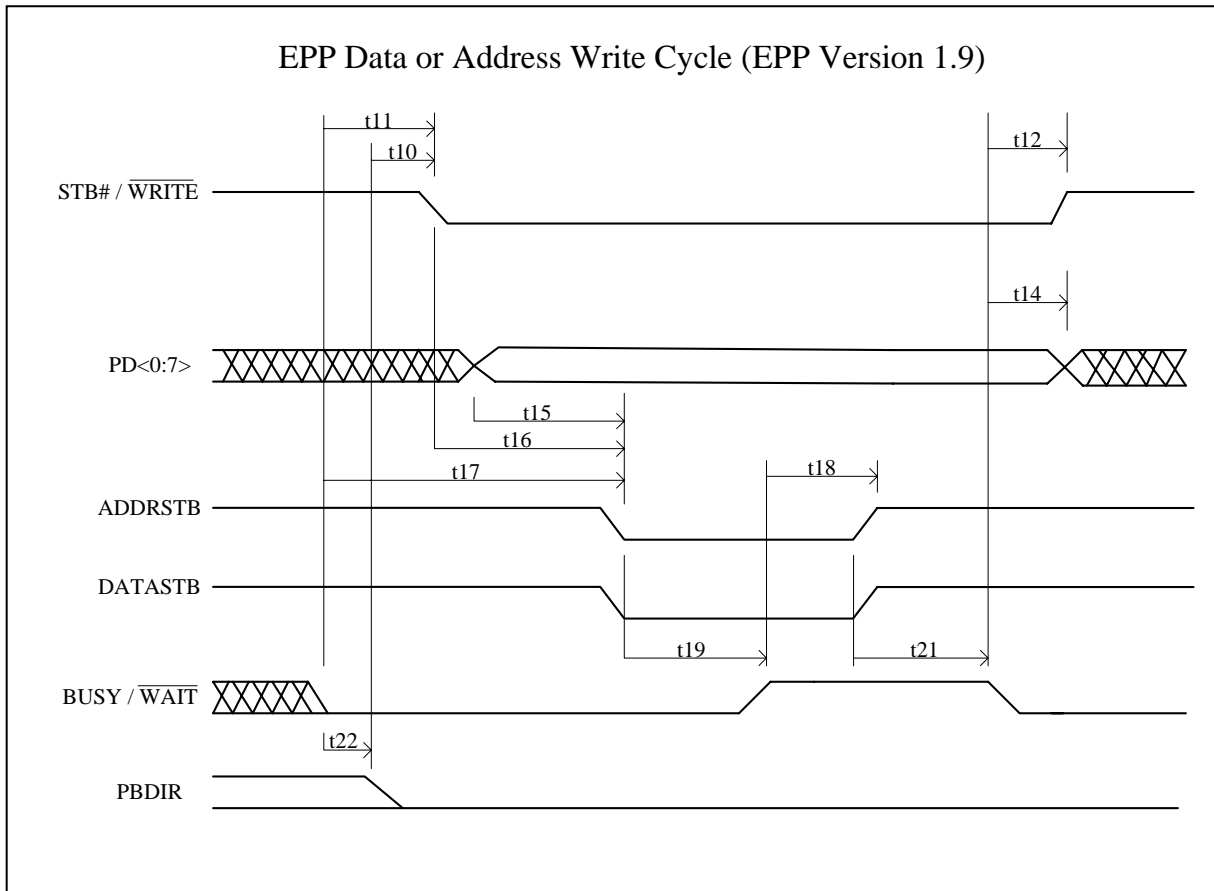





### 21.3.10.7. EPP Data or Address Write Cycle (EPP Version 1.7)

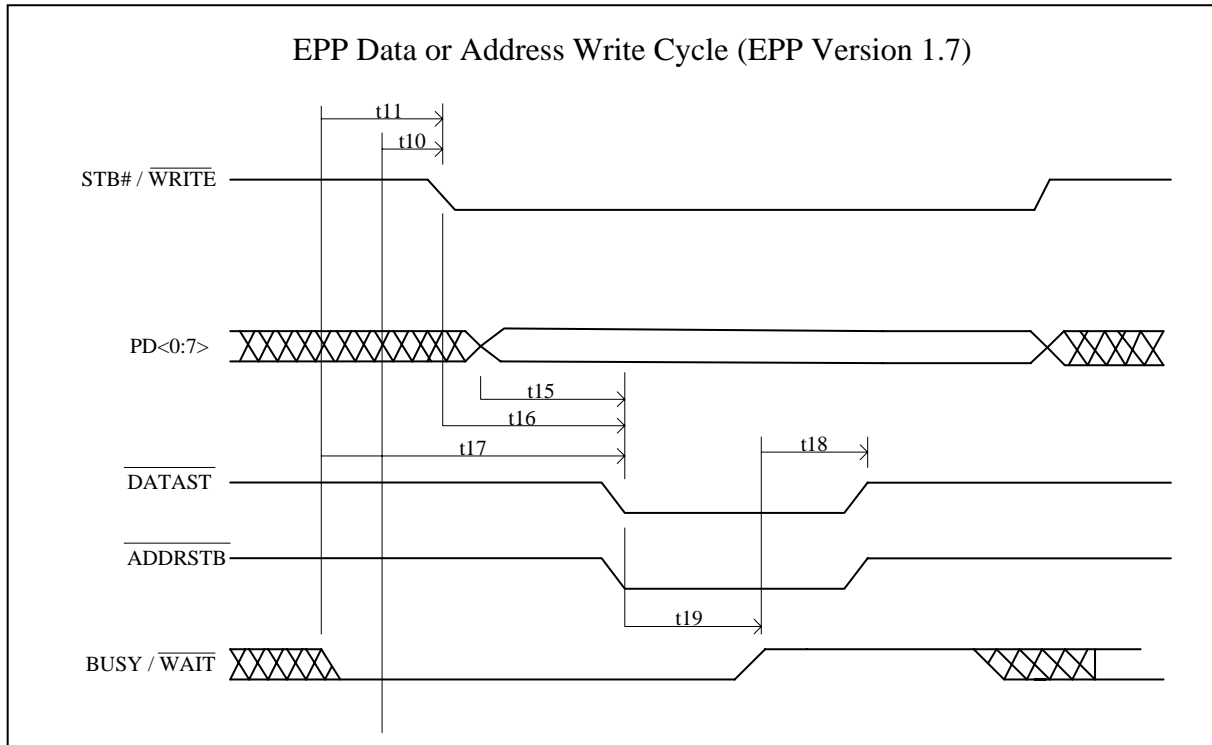

### 21.3.10.8. Parallel Port FIFO Timing Parameters

PARAMETER	SYMBOL	MIN.	MAX.	UNIT
DATA Valid to nSTROBE Active	t1	600		nS
nSTROBE Active Pulse Width	t2	600		nS
DATA Hold from nSTROBE Inactive	t3	450		nS
BUSY Inactive to PD Inactive	t4	80		nS
BUSY Inactive to nSTROBE Active	t5	680		nS
nSTROBE Active to BUSY Active	t6		500	nS



### 21.3.10.9. Parallel FIFO Timing

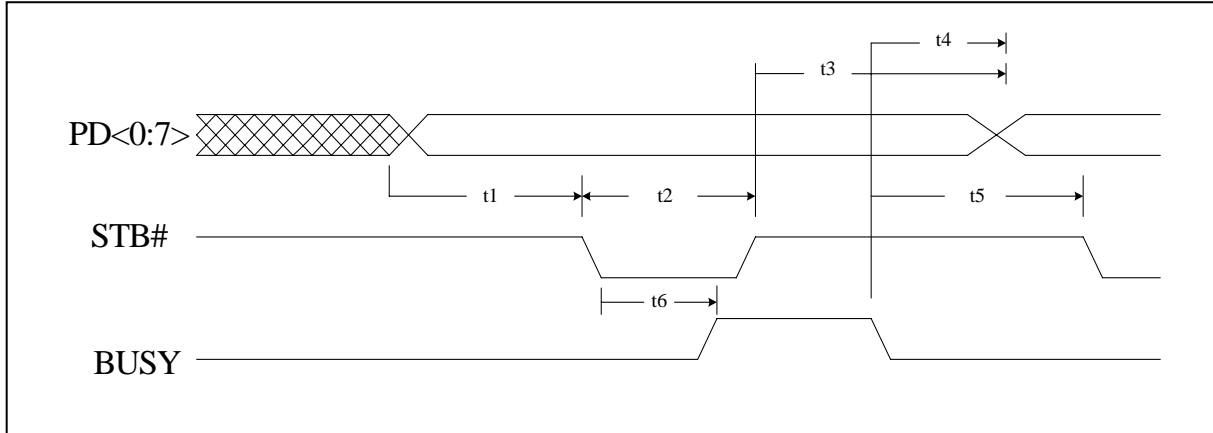

### 21.3.10.10. ECP Parallel Port Forward Timing Parameters

PARAMETER	SYMBOL	MIN.	MAX.	UNIT
nAUTOFD Valid to nSTROBE Asserted	t1	0	60	nS
PD Valid to nSTROBE Asserted	t2	0	60	nS
BUSY Deasserted to nAUTOFD Changed	t3	80	180	nS
BUSY Deasserted to PD Changed	t4	80	180	nS
nSTROBE Deasserted to BUSY Deasserted	t5	0		nS
BUSY Deasserted to nSTROBE Asserted	t6	80	200	nS
nSTROBE Asserted to BUSY Asserted	t7	0		nS
BUSY Asserted to nSTROBE Deasserted	t8	80	180	nS



### 21.3.10.11. ECP Parallel Port Forward Timing

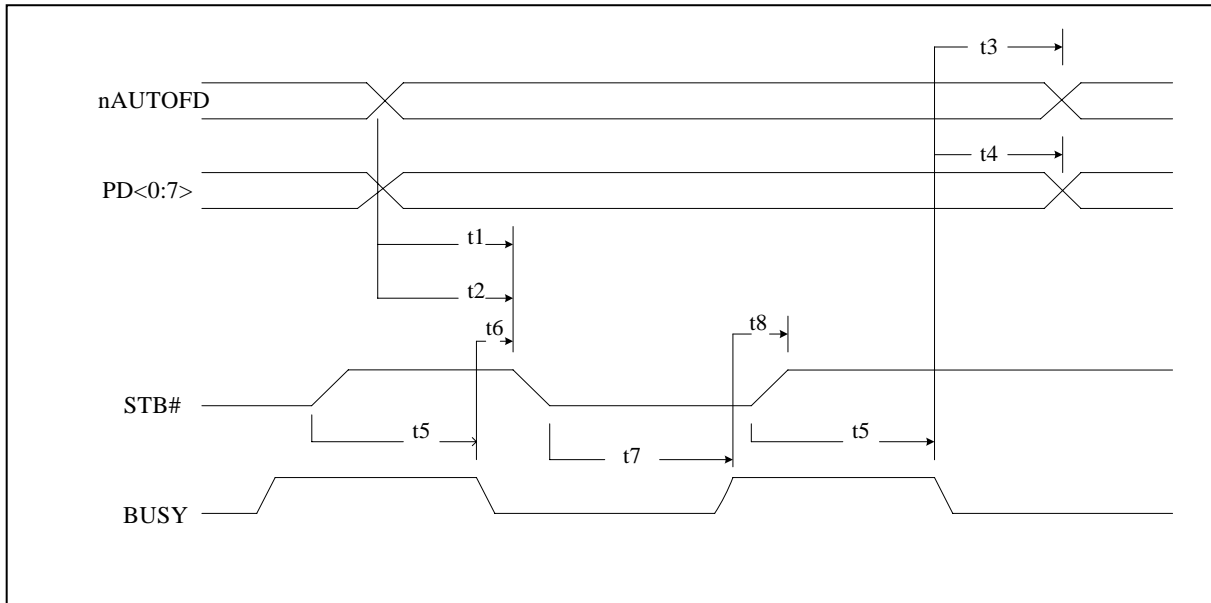

### 21.3.10.12. ECP Parallel Port Reverse Timing Parameters

PARAMETER	SYMBOL	MIN.	MAX.	UNIT
PD Valid to nACK Asserted	t1	0		nS
nAUTOFD Deasserted to PD Changed	t2	0		nS
nAUTOFD Asserted to nACK Asserted	t3	0		nS
nAUTOFD Deasserted to nACK Deasserted	t4	0		nS
nACK Deasserted to nAUTOFD Asserted	t5	80	200	nS
PD Changed to nAUTOFD Deasserted	t6	80	200	nS



### 21.3.10.13. ECP Parallel Port Reverse Timing

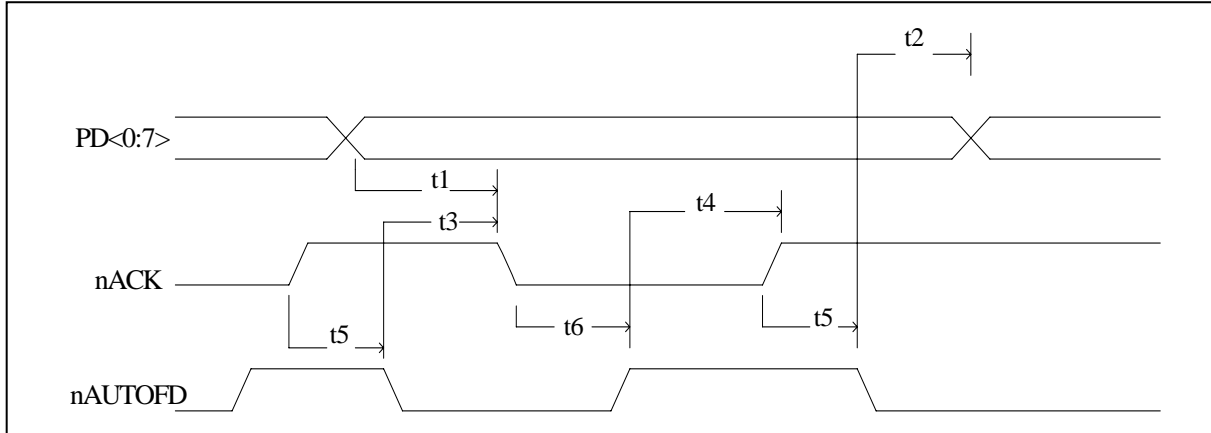

### 21.3.11 KBC Timing Parameters

SYMBOL	DESCRIPTION	MIN.	MAX.	UNIT
T1	Address Setup Time from WRB	0		nS
T2	Address Setup Time from RDB	0		nS
T3	WRB Strobe Width	20		nS
T4	RDB Strobe Width	20		nS
T5	Address Hold Time from WRB	0		nS
T6	Address Hold Time from RDB	0		nS
T7	Data Setup Time	50		nS
T8	Data Hold Time	0		nS
T9	Gate Delay Time from WRB	10	30	nS
T10	RDB to Drive Data Delay		40	nS
T11	RDB to Floating Data Delay	0	20	nS
T12	Data Valid After Clock Falling (SEND)		4	$\mu$ S
T13	K/B Clock Period	20		$\mu$ S
T14	K/B Clock Pulse Width	10		$\mu$ S
T15	Data Valid Before Clock Falling (RECEIVE)	4		$\mu$ S
T16	K/B ACK After Finish Receiving	20		$\mu$ S
T19	Transmit Timeout		2	mS
T20	Data Valid Hold Time	0		$\mu$ S
T21	Input Clock Period (6–16 Mhz)	63	167	nS



KBC Timing Parameters, continued

SYMBOL	DESCRIPTION	MIN.	MAX.	UNIT
T22	Duration of CLK inactive	30	50	$\mu\text{S}$
T23	Duration of CLK active	30	50	$\mu\text{S}$
T24	Time from inactive CLK transition, used to time when the auxiliary device sample DATA	5	25	$\mu\text{S}$
T25	Time of inhibit mode	100	300	$\mu\text{S}$
T26	Time from rising edge of CLK to DATA transition	5	T28-5	$\mu\text{S}$
T27	Duration of CLK inactive	30	50	$\mu\text{S}$
T28	Duration of CLK active	30	50	$\mu\text{S}$
T29	Time from DATA transition to falling edge of CLK	5	25	$\mu\text{S}$

### 21.3.11.1. Writing Cycle Timing

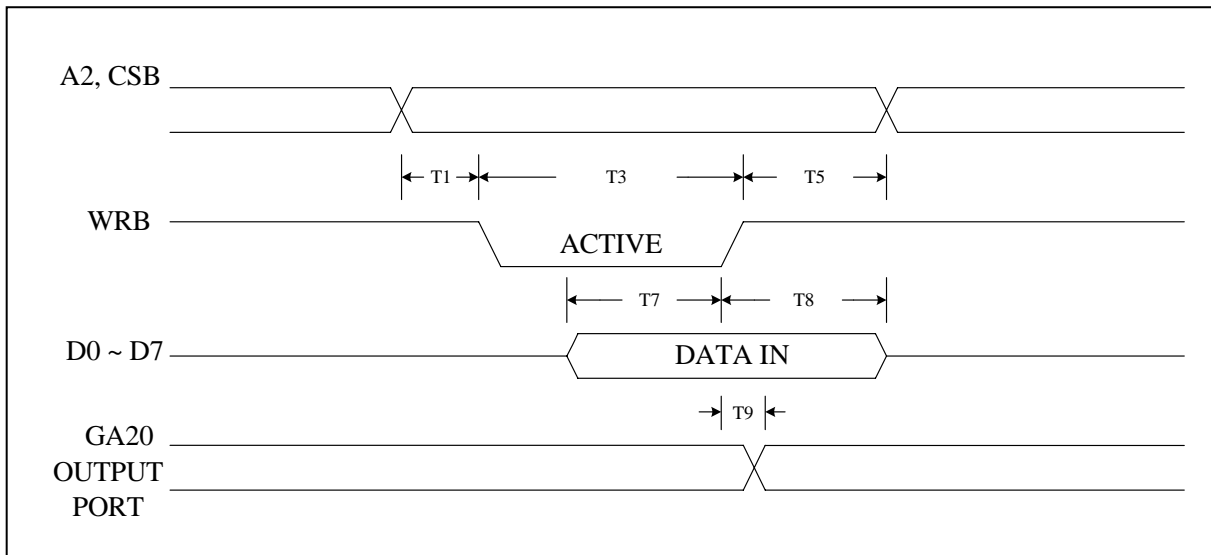



21.3.11.2. Read Cycle Timing

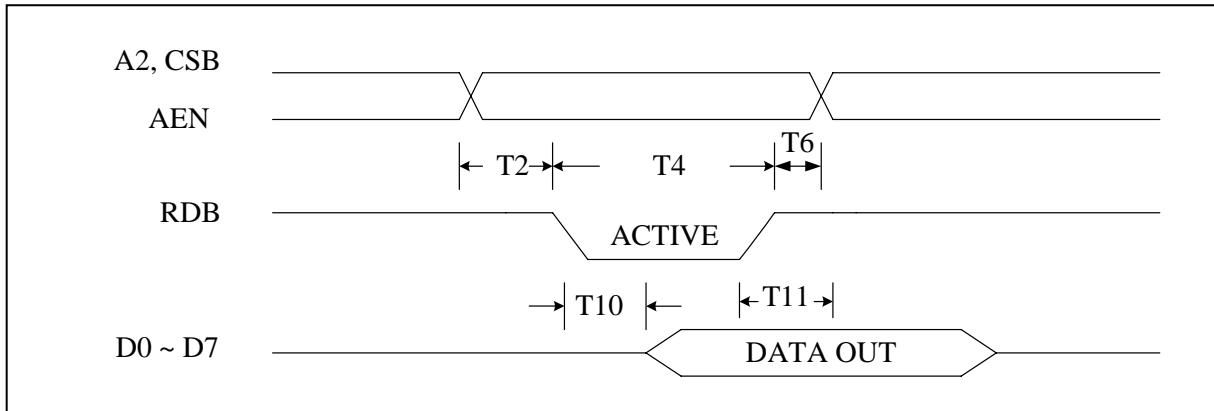

21.3.11.3. Send Data to K/B

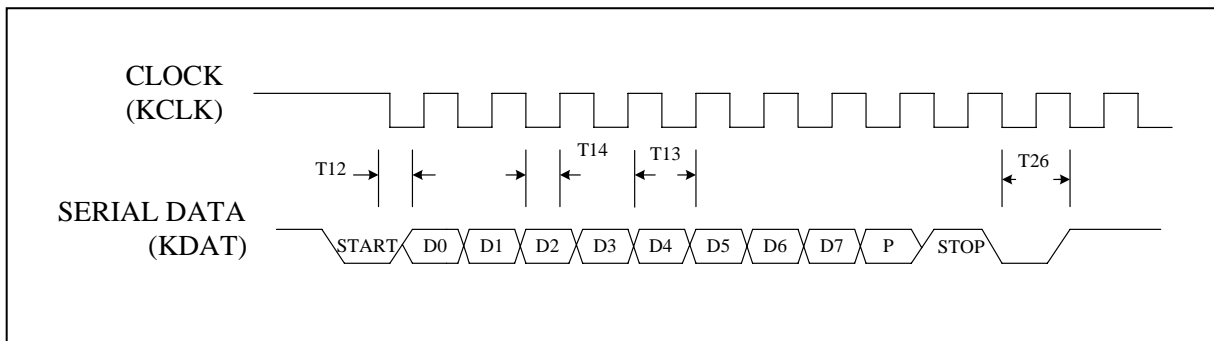

21.3.11.4. Receive Data from K/B

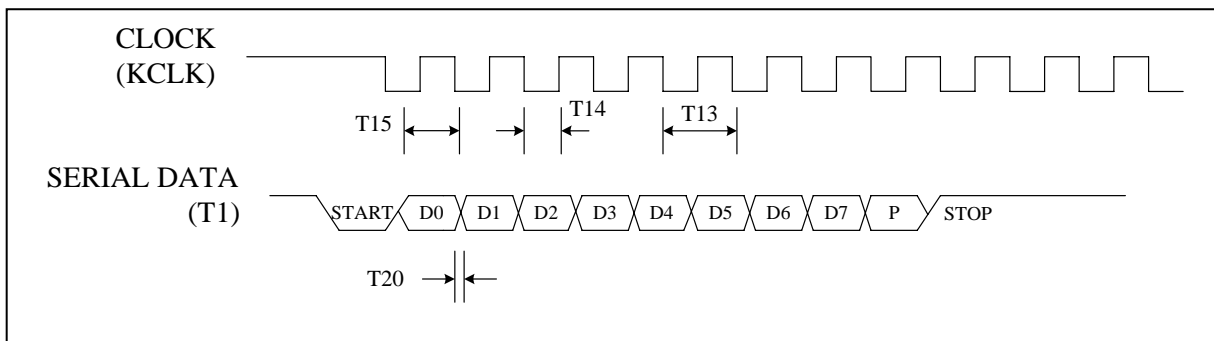



21.3.11.5. Input Clock

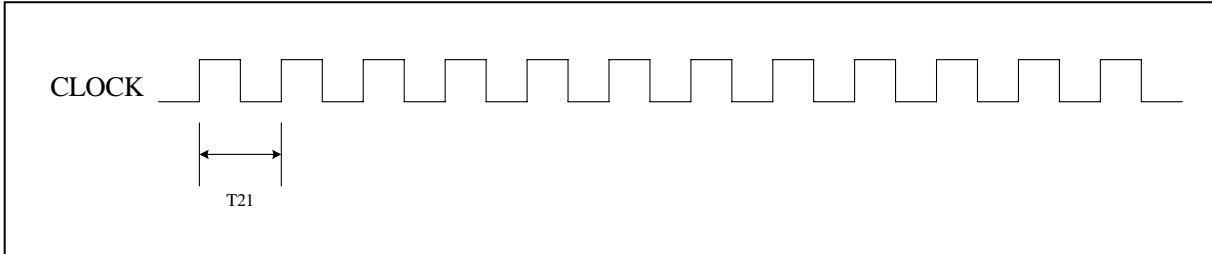

21.3.11.6. Send Data to Mouse

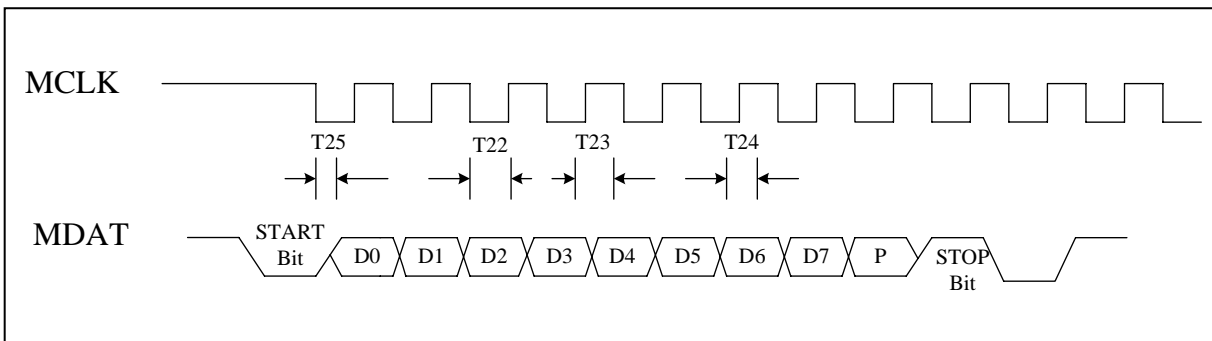

21.3.11.7. Receive Data from Mouse

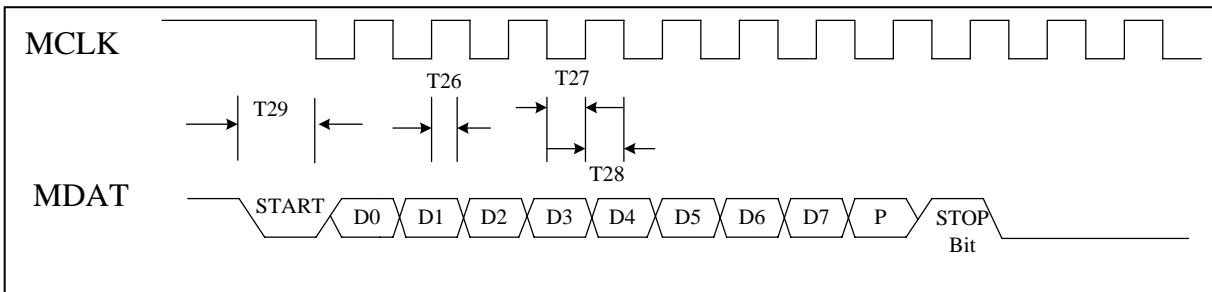

21.3.12 GPIO Timing Parameters

SYMBOL	PARAMETER	MIN.	MAX.	UNIT
$t_{WGO}$	Write data to GPIO update		300(Note 1)	ns
$t_{SWP}$	SWITCH pulse width	16		msec

Note: Refer to Microprocessor Interface Timing for Read Timing.



21.3.12.1. GPIO Write Timing

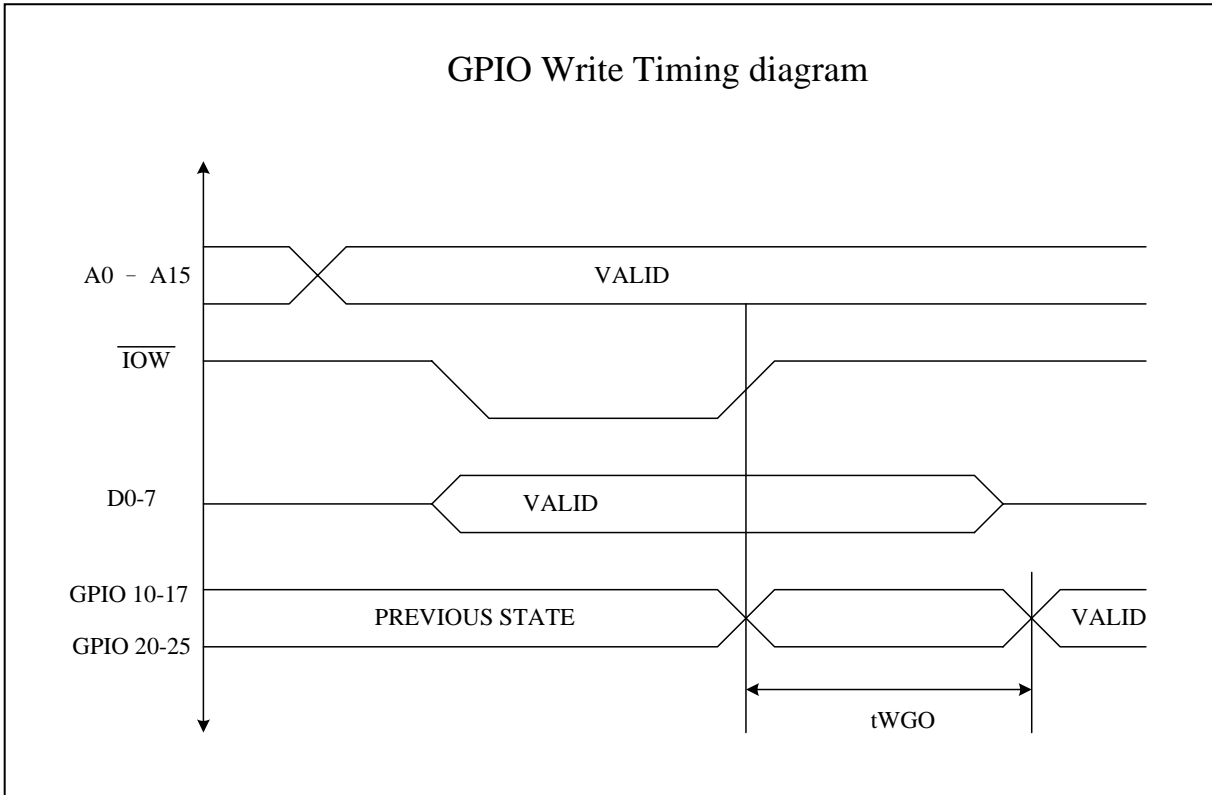





## 21.4 LPC Timing

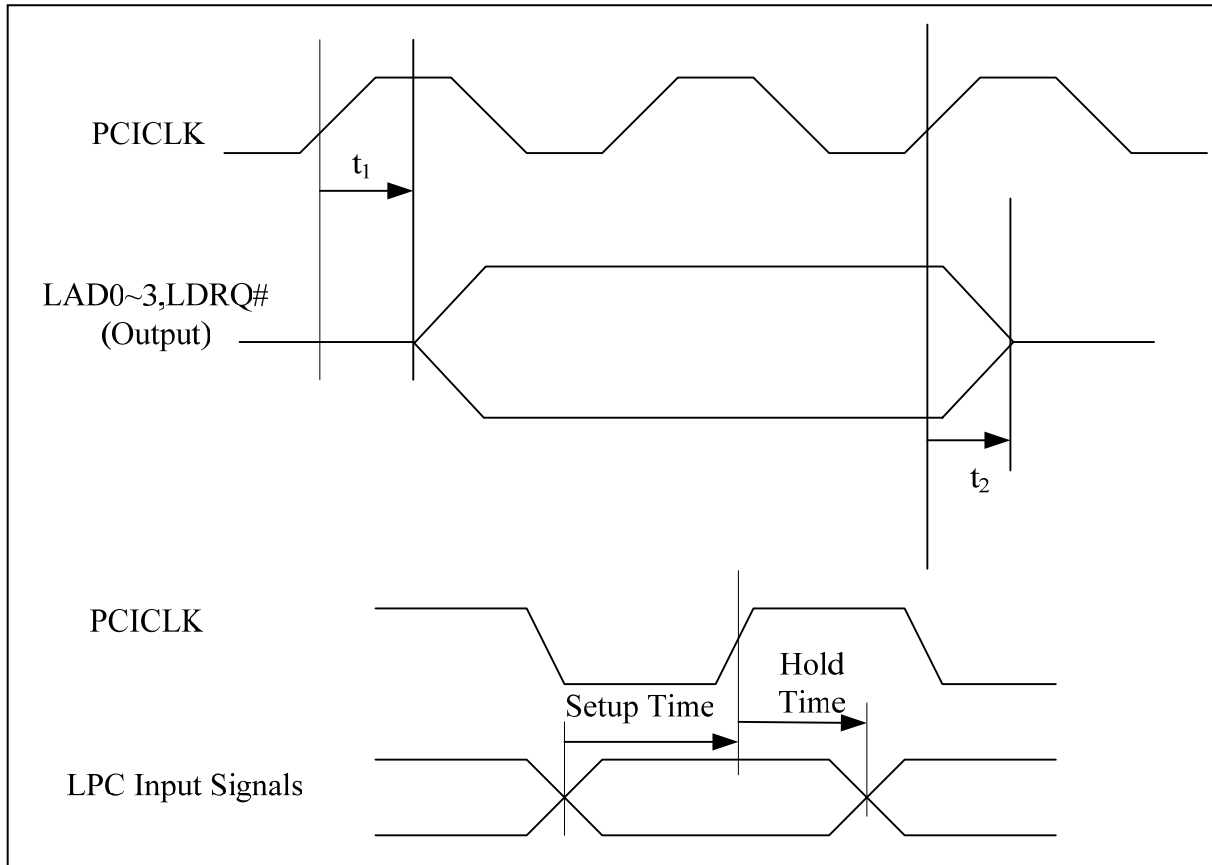

SYMBOL	DESCRIPTION	MIN.	MAX.	UNIT
$t_1$	Output Valid Delay	4	11	nS
$t_2$	Float Delay	4	11	nS
$t_3$	LAD[3:0] Setup Time	14		nS
$t_4$	LAD[3:0] Hold Time	0		nS
$t_5$	LFRAME# Setup Time	12		nS
$t_6$	LFRAME# Hold Time	0		nS

W83627DHG



22. TOP MARKING SPECIFICATION

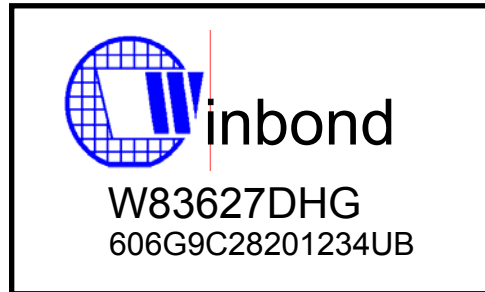

1st line: Winbond logo

2nd line: part number: W83627DHG (Pb-free package)

3rd line: tracking code 606G9C28201234UB

**606**: packages made in '06, week 06

**G**: assembly house ID; G means GR, A means ASE, etc.

**9**: code version; 9 means code 009

**C**: IC revision; A means version A; B means version B, and C means version C

**28201234**: wafer production series lot number

**UB**: Winbond internal use.



23. PACKAGE SPECIFICATION

Symbol	Dimension in mm			Dimension in inch		
	Min	Nom	Max	Min	Nom	Max
A <sub>1</sub>	0.25	0.35	0.45	0.010	0.014	0.018
A <sub>2</sub>	2.57	2.72	2.87	0.101	0.107	0.113
b	0.10	0.20	0.30	0.004	0.008	0.012
c	0.10	0.15	0.20	0.004	0.006	0.008
D	13.90	14.00	14.10	0.547	0.551	0.555
E	19.90	20.00	20.10	0.783	0.787	0.791
⌀	—	0.50	—	—	0.020	—
H <sub>b</sub>	17.00	17.20	17.40	0.669	0.677	0.685
H <sub>E</sub>	23.00	23.20	23.40	0.905	0.913	0.921
L	0.65	0.80	0.95	0.025	0.031	0.037
L <sub>1</sub>	—	1.60	—	—	0.063	—
y	—	—	0.08	—	—	0.003
θ	0	—	7	0	—	7

**Note:**

- 1.Dimension D & E do not include interlead flash.
- 2.Dimension b does not include dambar protrusion/intrusion .
- 3.Controlling dimension : Millimeter
- 4.General appearance spec. should be based on final visual inspection spec.
5. PCB layout please use the "mm".

128-pin (QFP)



### Important Notice

Winbond products are not designed, intended, authorized or warranted for use as components in systems or equipment intended for surgical implantation, atomic energy control instruments, airplane or spaceship instruments, transportation instruments, traffic signal instruments, combustion control instruments, or for other applications intended to support or sustain life. Further more, Winbond products are not intended for applications wherein failure of Winbond products could result or lead to a situation wherein personal injury, death or severe property or environmental damage could occur.

Winbond customers using or selling these products for use in such applications do so at their own risk and agree to fully indemnify Winbond for any damages resulting from such improper use or sales.

---

*Please note that all data and specifications are subject to change without notice.  
All the trademarks of products and companies mentioned in this datasheet belong to their respective owners.*