



DATA SHEET

2EZ11~2EZ39

GLASS PASSIVATED JUNCTION SILICON ZENER DIODES

VOLTAGE 11 to 39 Volts

POWER 2.0 Watts

DO-15

Unit: inch(mm)

FEATURES

- Low profile package
- Built-in strain relief
- Glass passivated junction
- Low inductance
- Typical I_D less than 1.0 μ A above 11V
- Plastic package has Underwriters Laboratory Flammability Classification 94V-0
- High temperature soldering : 260°C /10 seconds at terminals
- Pb free product are available : 99% Sn above meet Rohs environment substance directive request

MECHANICAL DATA

Case: JEDEC DO-15, Molded plastic over passivated junction
 Terminals: Solder plated, solderable per MIL-STD-202G, Method 208
 Polarity: Color band denotes positive end (cathode)
 Standard packing: 52mm tape
 Weight: 0.015 ounce, 0.04 gram

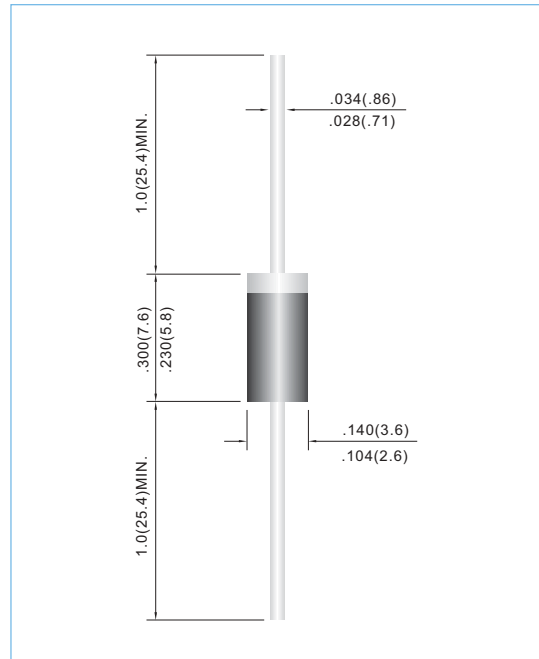

MAXIMUM RATINGS AND ELECTRICAL CHARACTERISTICS

Ratings at 25°C ambient temperature unless otherwise specified.

Parameter	Symbol	Value	Units
Pwak Pulse Power Dissipation on TA=50°C (Notes A) Derate above 70°C	P_D	2 24.0	Watts mW/°C
Peak Forward Surge Current 8.3ms single half sine-wave superimposed on rated load (JEDEC method)	I_{FSM}	15	Amps
Operating Junction and Storage Temperature Range	T_J, T_{STG}	-55 to + 150	°C

NOTES:

A. Mounted on 5.0mm² (.013mm thick) land areas.

B. Measured on 8.3ms, and single half sine-wave or equivalent square wave, duty cycle=4 pulses per minute maximum



Part Number	Nominal Zener Voltage			Maximum Zener Impedance				Leakage Current	
	V _Z @ I _{ZT}			Z _{ZT} @ I _{ZT}	I _{ZT}	Z _{ZK} @ I _{ZK}	I _{ZK}	I _R @ V _R	
	Nom. V	Min. V	Max. V	Ohms	mA	Ohms	mA	uA	V
3.0 Watt ZENER									
2EZ11	11.0	10.05	11.6	4.0	45.5	700	0.25	1.0	8.4
2EZ12	12.0	11.4	12.6	4.5	41.5	700	0.25	1.0	9.1
2EZ13	13.0	12.4	13.7	5.0	38.5	700	0.25	0.5	9.9
2EZ14	14.0	13.3	14.7	5.5	35.7	700	0.25	0.5	10.6
2EZ15	15.0	14.3	15.8	7.0	33.4	700	0.25	0.5	11.4
2EZ16	16.0	15.2	16.8	8.0	31.2	700	0.25	0.5	12.2
2EZ17	17.0	16.2	17.9	9.0	29.4	750	0.25	0.5	13.0
2EZ18	18.0	17.1	18.9	10.0	27.8	750	0.25	0.5	13.7
2EZ19	19.0	18.1	20.0	11.0	26.3	750	0.25	0.5	14.4
2EZ20	20.0	19.0	21.0	11.0	25.0	750	0.25	0.5	15.2
2EZ22	22.0	20.9	23.1	12.0	22.8	750	0.25	0.5	16.7
2EZ24	24.0	22.8	25.2	13.0	20.8	750	0.25	0.5	18.2
2EZ27	27.0	25.7	28.4	18.0	18.5	750	0.25	0.5	20.6
2EZ28	28.0	26.6	29.4	19.0	17.0	750	0.25	0.5	21.0
2EZ30	30.0	28.5	31.5	20.0	16.6	1000	0.25	0.5	22.5
2EZ33	33.0	31.4	34.7	23.0	15.1	1000	0.25	0.5	25.1
2EZ36	36.0	34.2	37.8	25.0	13.9	1000	0.25	0.5	27.4
2EZ39	39.0	37.1	41.0	30.0	12.8	1000	0.25	0.5	29.7

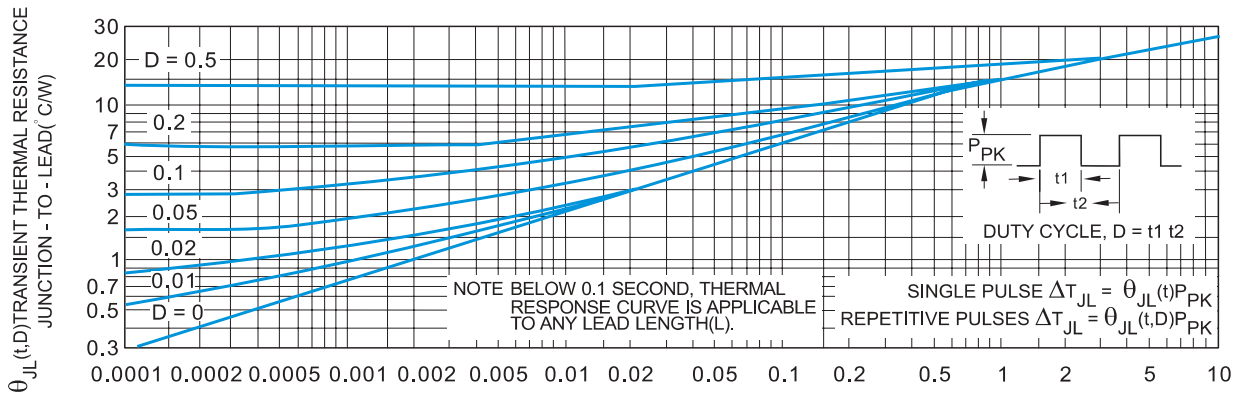

FIGURE 2. TYPICAL THERMAL RESPONSE L,

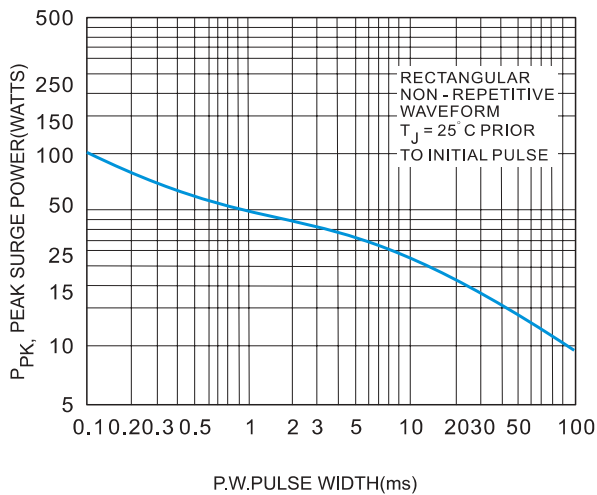

FIGURE 3. MAXIMUM SURGE POWER

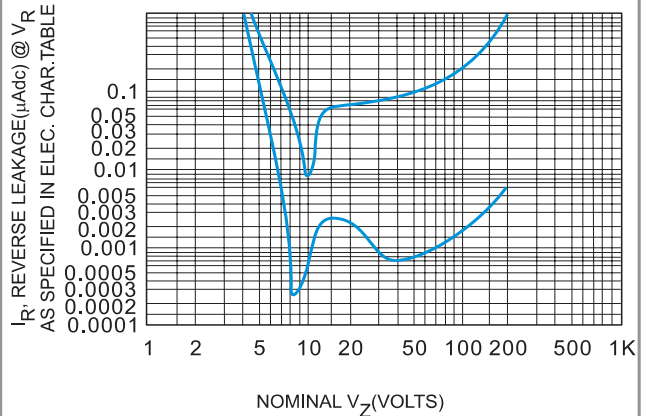

FIGURE 4. TYPICAL REVERSE LEAKAGE

APPLICATION NOTE:

Since the actual voltage available from a given zener diode is temperature dependent, it is necessary to determine junction temperature under any set of operating conditions in order to calculate its value. The following procedure is recommended: Lead Temperature, T_L , should be determined from:

$$T_L = \theta_{LA} P_D + T_A$$

θ_{LA} is the lead-to-ambient thermal resistance ($^{\circ}C/W$) and P_D is the power dissipation. The value for θ_{LA} will vary and depends on the device mounting method. θ_{LA} is generally $30-40^{\circ}C/W$ for the various clips and tie points in common use and for printed circuit board wiring.

The temperature of the lead can also be measured using a thermocouple placed on the lead as close as possible to the tie point. The thermal mass connected to the tie point is normally large enough so that it will not significantly respond to heat surges generated in the diode as a result of pulsed operation once steady-state conditions are achieved. Using the measured value of T_L , the junction temperature may be determined by:

$$T_J = T_L + \Delta T_{JL}$$

ΔT_{JL} is the increase in junction temperature above the lead temperature and may be found from Figure 2 for a train of power pulses or from Figure 10 for dc power.

$$\Delta T_{JL} = \theta_{JL} P_D$$

For worst-case design, using expected limits of I_Z , limits of P_D and the extremes of T_J (ΔT_J) may be estimated. Changes in voltage V_Z , can then be found from:

$$\Delta V = \theta_{VZ} \Delta T_J$$

θ_{VZ} , the zener voltage temperature coefficient, is found from Figures 5 and 6.

Under high power-pulse operation, the zener voltage will vary with time and may also be affected significantly by the zener resistance. For best regulation, keep current excursions as low as possible.

Data of Figure 2 should not be used to compute surge capability. Surge limitations are given in Figure 3. They are lower than what would be expected by considering only junction temperature, as current crowding effects cause temperatures to be extremely high in spots resulting in device degradation should the limits of Figure 3 be exceeded.

