

Cost-Effective, 2A Peak Sink/Source Bus Termination Regulator

General Description

The RT9199 is a simple, cost-effective and high-speed linear regulator designed to generate termination voltage in double data rate (DDR) memory system to comply with the devices requirements. The regulator is capable of actively sinking or sourcing up to 2A peak while regulating an output voltage to within 20mV. The output termination voltage can be tightly regulated to track $1/2V_{DDQ}$ by two external voltage divider resistors or the desired output voltage can be pro-programmed by externally forcing the REFEN pin voltage.

The RT9199 also incorporates a high-speed differential amplifier to provide ultra-fast response in line/load transient. Other features include extremely low initial offset voltage, excellent load regulation, current limiting in bi-directions and on-chip thermal shut-down protection.

The RT9199 are available in both SOP-8 and SOP-8 (Exposed Pad) surface mount packages.

Ordering Information

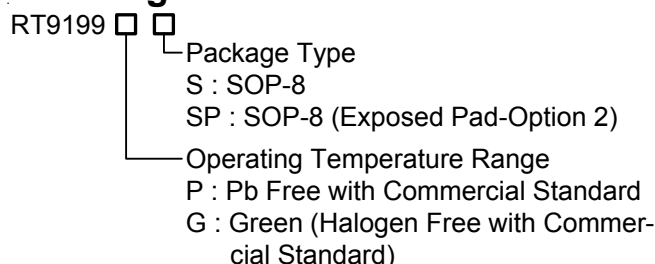

Note :

Richtek Pb-free and Green products are :

- ▶RoHS compliant and compatible with the current requirements of IPC/JEDEC J-STD-020.
- ▶Suitable for use in SnPb or Pb-free soldering processes.
- ▶100%matte tin (Sn) plating.

Features

- Ideal for DDR-II V_{TT} Applications
- Sink and Source 2A Peak Current
- Integrated Power MOSFETs
- Generate Termination Voltage for DDR Memory Interfaces
- High Accuracy Output Voltage at Full-Load
- Output Adjustment by Two External Resistors
- Low External Component Count
- Shutdown for Suspend to RAM (STR) Functionality with High-Impedance Output
- Current Limiting Protection
- On-Chip Thermal Protection
- RoHS Compliant and 100% Lead (Pb)-Free

Applications

- Desktop PCs, Notebooks, and Workstations
- Graphics Card Memory Termination
- Set Top Boxes, Digital TVs, Printers
- Embedded Systems
- Active Termination Buses
- DDR/II Memory Systems

Pin Configurations

(TOP VIEW)

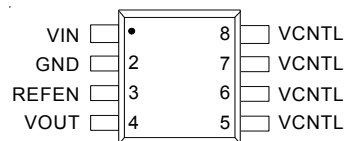

SOP-8

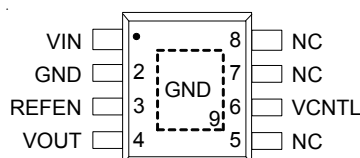

SOP-8 (Exposed Pad)

Typical Application Circuit

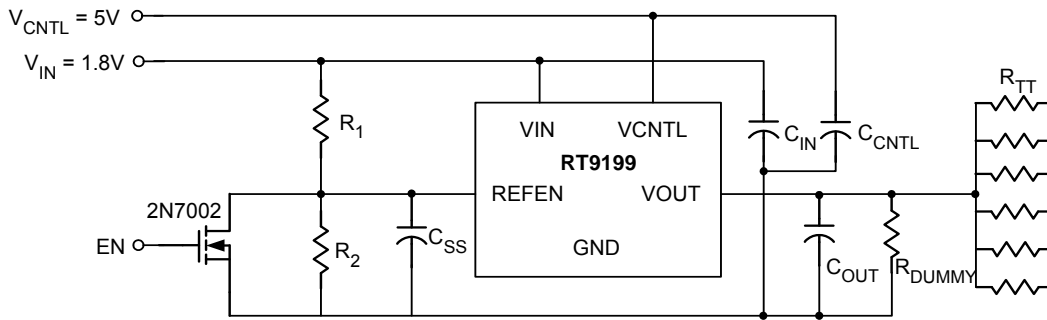

$R_1 = R_2 = 100k\Omega$, $R_{TT} = 50\Omega / 33\Omega / 25\Omega$

$C_{OUT(MIN)} = 10\mu F$ (Ceramic) + $1000\mu F$ under the worst case testing condition

$R_{DUMMY} = 1k\Omega$ as for V_{OUT} discharge when V_{IN} is not presented but V_{CNTRL} is presented

$C_{SS} = 1\mu F$, $C_{IN} = 470\mu F$ (Low ESR), $C_{CNTRL} = 47\mu F$

Test Circuit

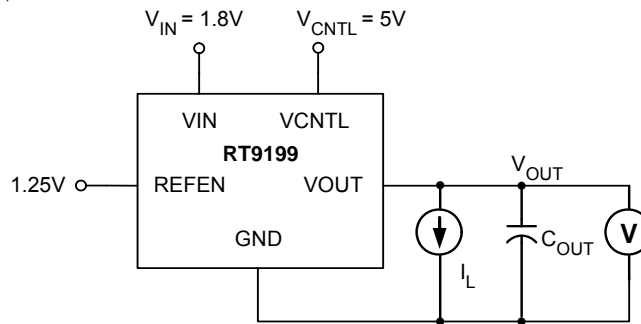

Figure 1. Output Voltage Tolerance, ΔV_{LOAD}

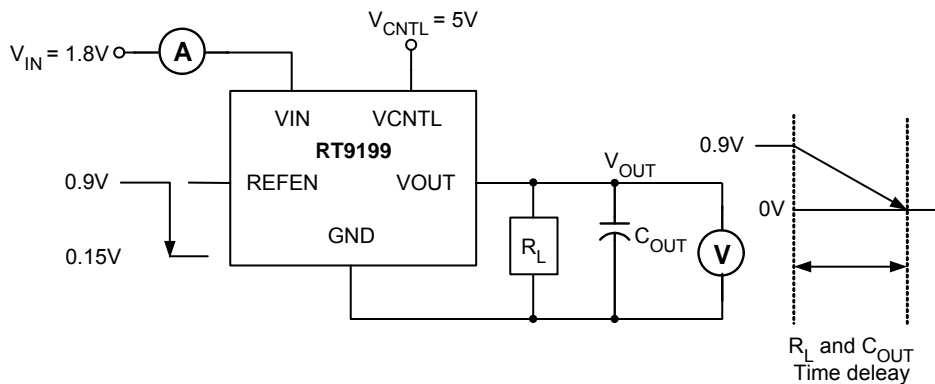

Figure 2. Current in Shutdown Mode, I_{STBY}

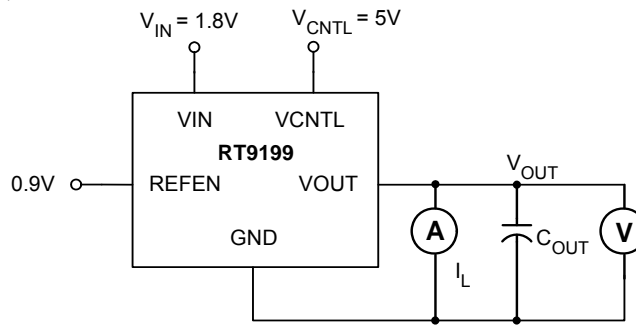

Figure 3. Current Limit for High Side, I_{LIM}

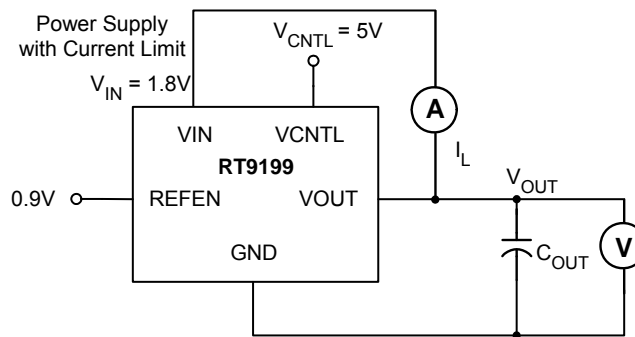

Figure 4. Current Limit for Low Side, I_{LIM}

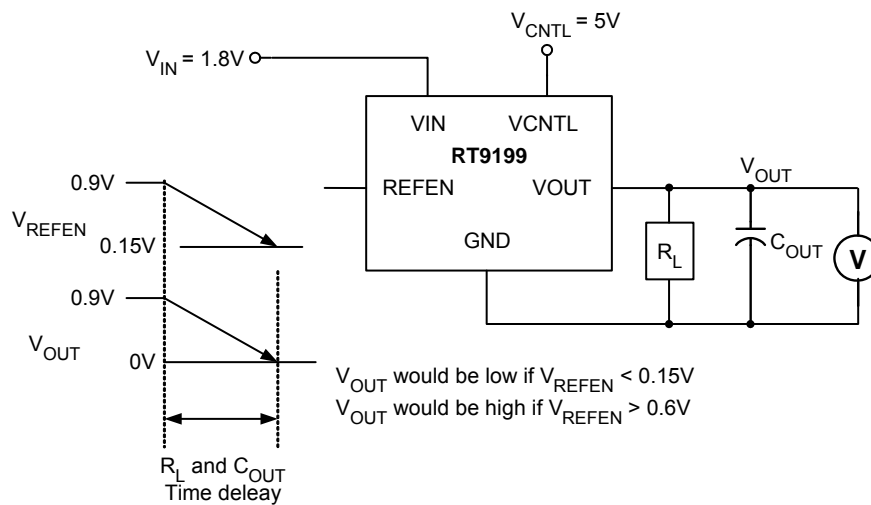

Figure 5. REFEN Pin Shutdown Threshold, V_{IH} & V_{IL}

Functional Pin Description

VIN

Input voltage which supplies current to the output pin. Connect this pin to a well-decoupled supply voltage. To prevent the input rail from dropping during large load transient, a large, low ESR capacitor is recommended to use. The capacitor should be placed as close as possible to the VIN pin.

GND (Exposed Pad)

Common Ground. The exposed pad must be soldered to a large PCB and connected to GND for maximum power dissipation.

VCNTL

VCNTL supplies the internal control circuitry and provides the drive voltage. The driving capability of output current is proportioned to the VCNTL. Connect this pin to 5V bias supply to handle large output current with at least 1 μ F capacitor from this pin to GND. An important note is that VIN should be kept lower or equal to VCNTL.

REFEN

Reference voltage input and active low shutdown control pin. Two resistors dividing down the VIN voltage on the pin to create the regulated output voltage. Pulling the pin to ground turns off the device by an open-drain, such as 2N7002, signal N-MOSFET.

VOUT

Regulator output. VOUT is regulated to REFEN voltage that is used to terminate the bus resistors. It is capable of sinking and sourcing current while regulating the output rail. To maintain adequate large signal transient response, typical value of 1000 μ F Al electrolytic capacitor with 10 μ F ceramic capacitors are recommended to reduce the effects of current transients on VOUT.

Function Block Diagram

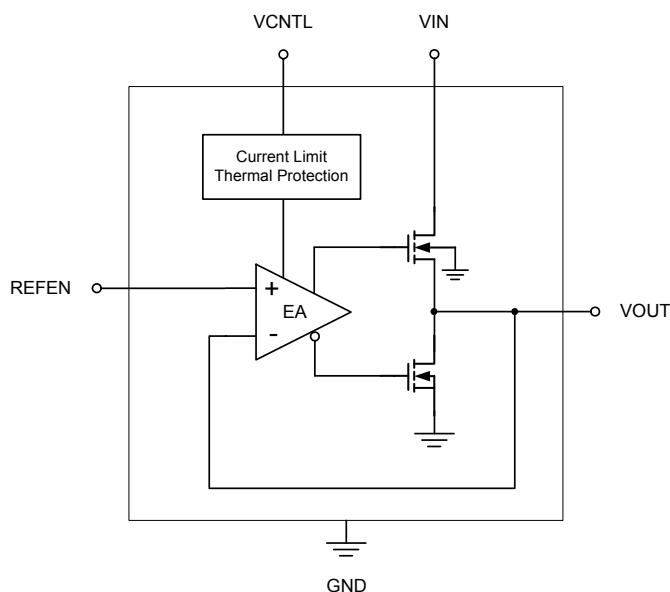

Absolute Maximum Ratings (Note 1)

- Input Voltage, V_{IN} ----- 6V
- Control Voltage, V_{CNTL} ----- 6V
- Power Dissipation, $P_D @ T_A = 25^\circ C$
 - SOP-8 ----- 0.909W
 - SOP-8 (Exposed Pad) ----- 1.176W
- Package Thermal Resistance (Note 4)
 - SOP-8, θ_{JA} ----- $110^\circ C/W$
 - SOP-8, θ_{JC} ----- $60^\circ C/W$
 - SOP-8 (Exposed Pad), θ_{JA} ----- $86^\circ C/W$
 - SOP-8 (Exposed Pad), θ_{JC} ----- $15^\circ C/W$
- Junction Temperature ----- $125^\circ C$
- Lead Temperature (Soldering, 10 sec.) ----- $260^\circ C$
- Storage Temperature Range ----- $-65^\circ C$ to $150^\circ C$
- ESD Susceptibility (Note 2)
 - HBM (Human Body Mode) ----- 2kV
 - MM (Machine Mode) ----- 200V

Recommended Operating Conditions (Note 3)

- Input Voltage, V_{IN} ----- 1.6V to 5.5V
- Control Voltage, V_{CNTL} ----- $5V \pm 5\%$
- Junction Temperature Range ----- $-40^\circ C$ to $125^\circ C$

Electrical Characteristics

($V_{IN} = 1.8V$, $V_{CNTL} = 5V$, $V_{REFEN} = 0.9V$, $C_{OUT} = 10\mu F$ (Ceramic), $T_A = 25^\circ C$, unless otherwise specified)

Parameter	Symbol	Test Conditions	Min	Typ	Max	Units
Input						
VCNTL Operation Current	I_{CNTL}	$I_{OUT} = 0A$	--	1	2.5	mA
Standby Current (Note 7)	I_{STBY}	$V_{REFEN} < 0.2V$ (Shutdown), $R_{LOAD} = 180\Omega$	--	2	90	μA
Output (DDR II)						
Output Offset Voltage (Note 5)	V_{OS}	$I_{OUT} = 0A$	-20	--	+20	mV
Load Regulation (Note 6)	ΔV_{LOAD}	$I_{OUT} = +1.8A$	-20	--	+20	mV
		$I_{OUT} = -1.8A$				
Protection						
Current limit	I_{LIMIT}		2.0	--	3.5	A
Thermal Shutdown Temperature	T_{SD}	$V_{CNTL} = 5V$	125	170	--	$^\circ C$
Thermal Shutdown Hysteresis	ΔT_{SD}	$V_{CNTL} = 5V$	--	35	--	$^\circ C$
REFEN Shutdown						
Shutdown Threshold	V_{IH}	Enable	0.6	--	--	V
	V_{IL}	Shutdown	--	--	0.15	

- Note 1.** Stresses listed as the above "Absolute Maximum Ratings" may cause permanent damage to the device. These are for stress ratings. Functional operation of the device at these or any other conditions beyond those indicated in the operational sections of the specifications is not implied. Exposure to absolute maximum rating conditions for extended periods may remain possibility to affect device reliability.
- Note 2.** Devices are ESD sensitive. Handling precaution recommended.
- Note 3.** The device is not guaranteed to function outside its operating conditions.
- Note 4.** θ_{JA} is measured in the natural convection at $T_A = 25^\circ\text{C}$ on a high effective thermal conductivity test board (4 Layers, 2S2P) of JEDEC 51-7 thermal measurement standard. The case point of θ_{JC} is on the exposed pad for SOP-8 (Exposed Pad) package.
- Note 5.** V_{OS} offset is the voltage measurement defined as V_{OUT} subtracted from V_{REFEN} .
- Note 6.** Regulation is measured at constant junction temperature by using a 5ms current pulse. Devices are tested for load regulation in the load range from 0A to 2A peak.
- Note 7.** Standby current is the input current drawn by a regulator when the output voltage is disabled by a shutdown signal on REFEN pin ($V_{IL} < 0.15\text{V}$). It is measured with $V_{IN} = V_{CNTL} = 5\text{V}$.

Typical Operating Characteristics

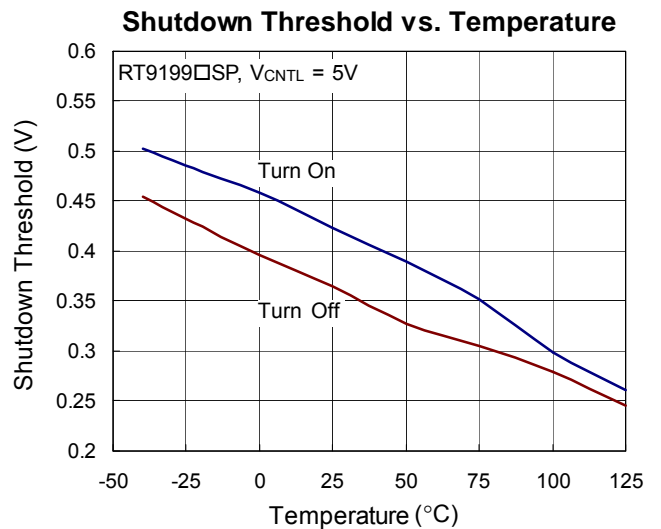
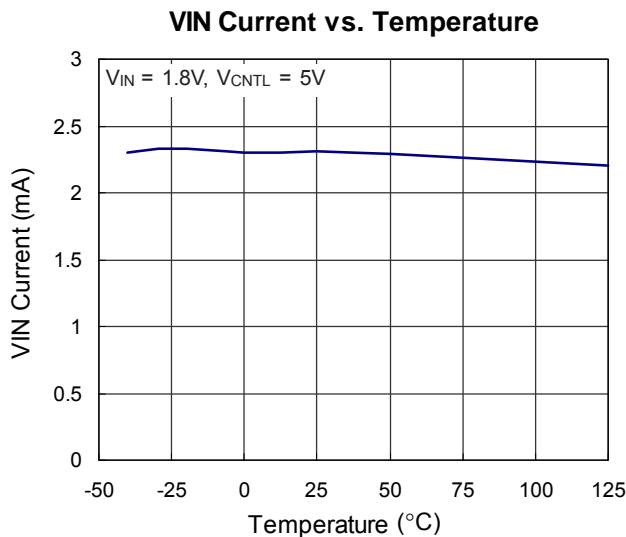
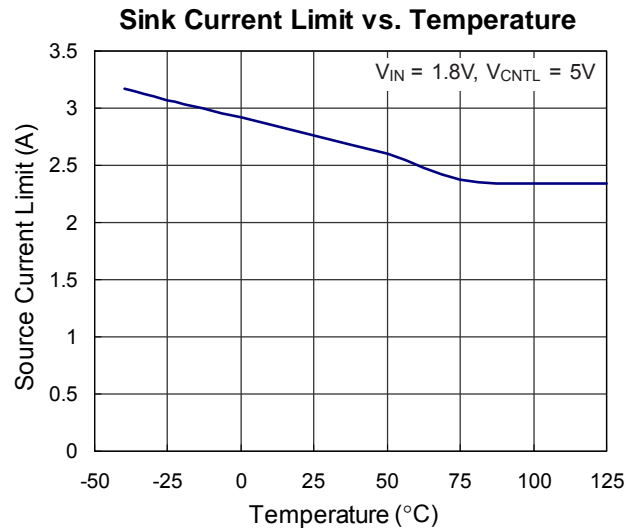
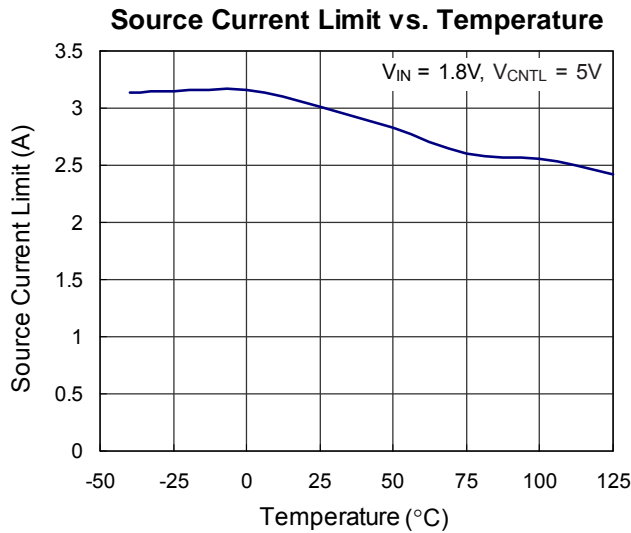
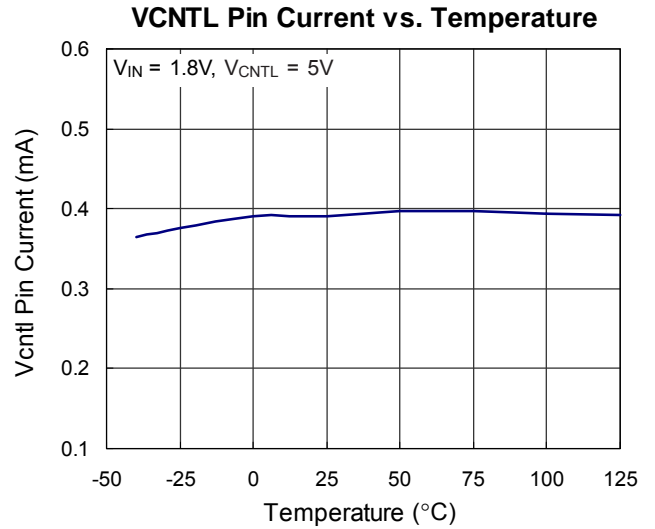
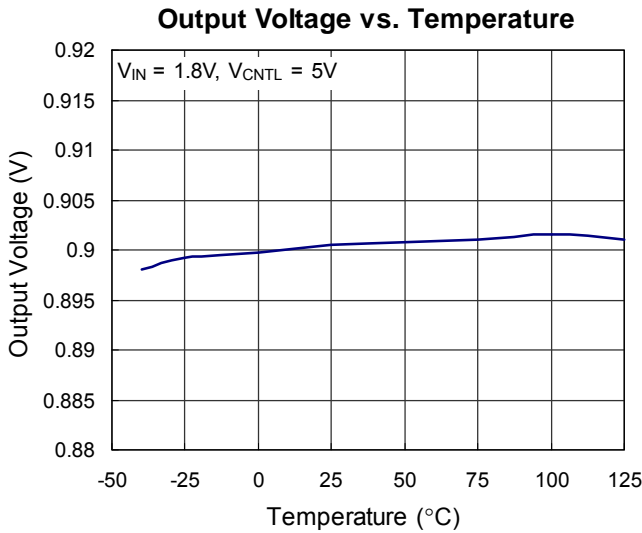

Output Short-Circuit Protection

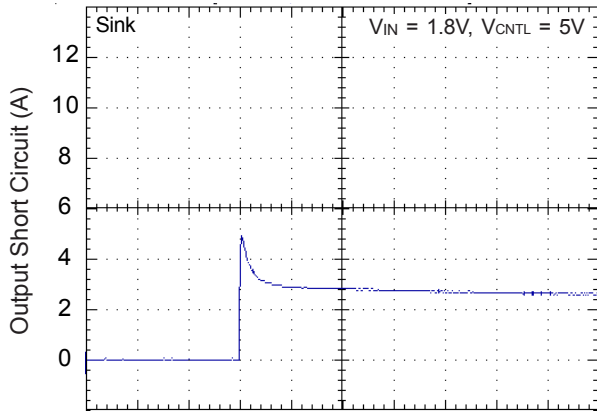

Time (1ms/Div)

Output Short-Circuit Protection

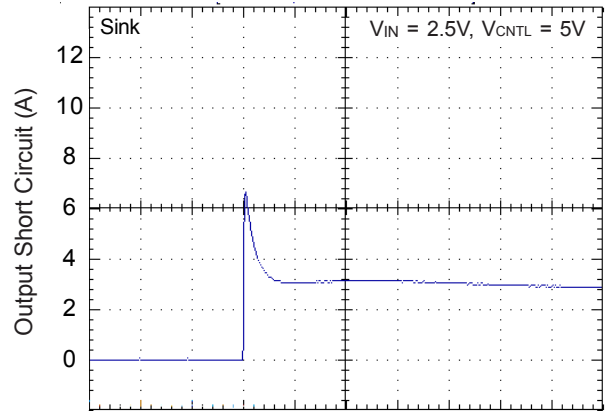

Time (1ms/Div)

Output Short-Circuit Protection

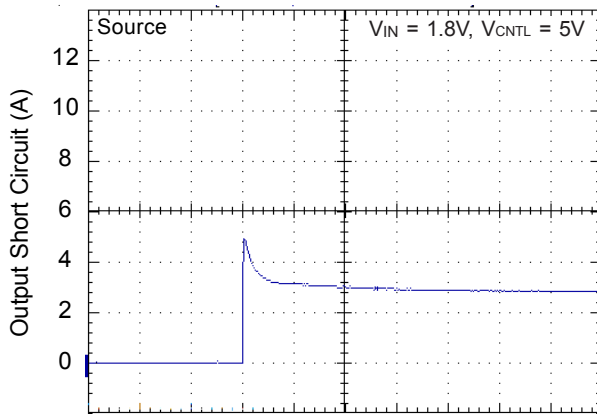

Time (1ms/Div)

Output Short-Circuit Protection

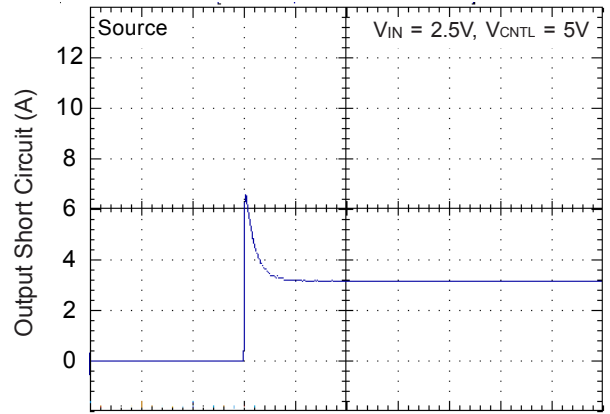

Time (1ms/Div)

0.9V_{TT} @ 1.8A Transient Response

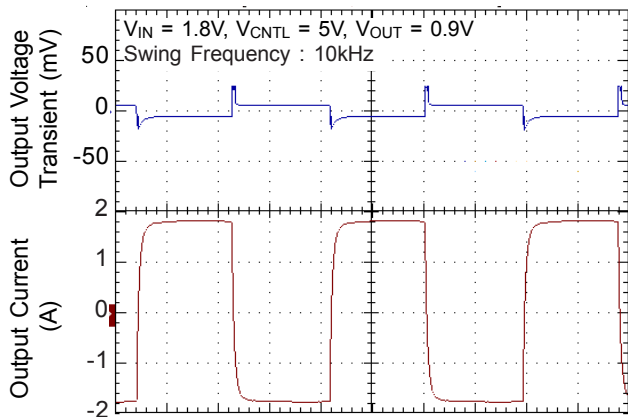

Time (25µs/Div)

1.25V_{TT} @ 1.8A Transient Response

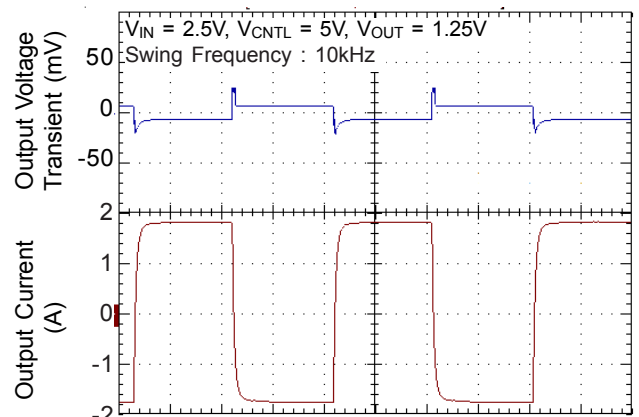

Time (25µs/Div)

Application Information

Consideration while designing the resistance of voltage divider

Refer to the "Typical Application Circuit". Make sure the current sinking capability of pull-down NMOS is enough for the chosen voltage divider to pull-down the voltage at REFEN pin below 0.15V to shutdown the device.

In addition, the capacitor C_{SS} and voltage divider form the low-pass filter. There are two reasons doing this design; one is for output voltage soft-start while another is for noise immunity.

How to reduce power dissipation on Notebook PC or the dual channel DDR SDRAM application?

In notebook application, using RichTek's Patent "Distributed Bus Terminator Topology" with choosing RichTek's product is encouraged.

Distributed Bus Terminating Topology

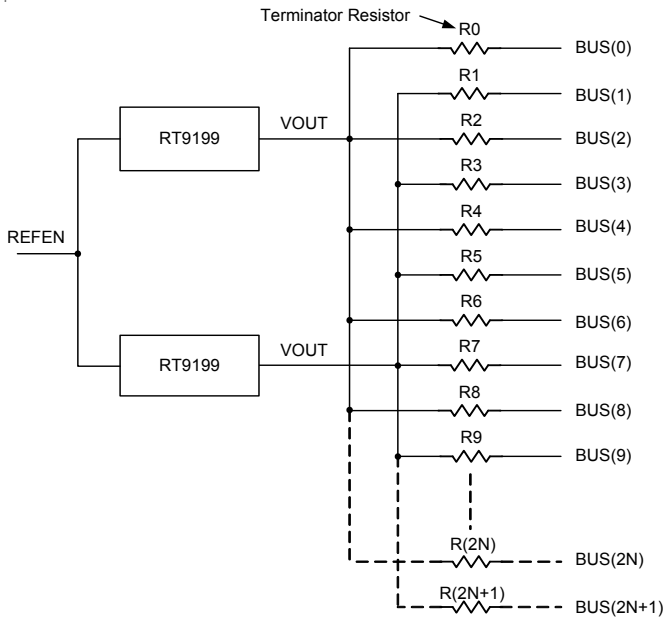

General Regulator

The RT9199 could also serve as a general linear regulator. The RT9199 accepts an external reference voltage at REFEN pin and provides output voltage regulated to this reference voltage as shown in Figure 6, where

$$V_{OUT} = V_{REFEN} \times R2 / (R1 + R2)$$

As other linear regulator, dropout voltage and thermal issue should be specially considered. Figure 7 shows the $R_{DS(ON)}$ over temperature of RT9199. The minimum dropout voltage

could be obtained by the product of $R_{DS(ON)}$ and output current. For thermal consideration, please refer to the relative sections.

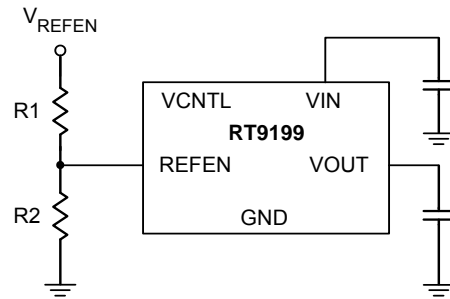

Figure 6

$R_{DS(ON)}$ vs. Temperature

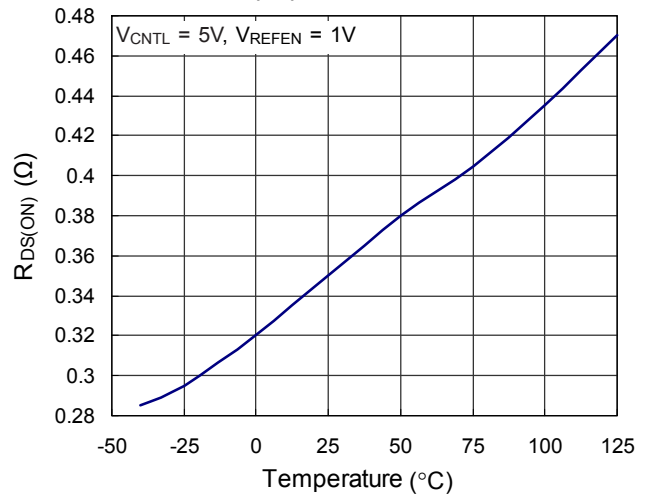

Figure 7

Input Capacitor and Layout Consideration

Place the input bypass capacitor as close as possible to the RT9199. A low ESR capacitor larger than 470uF is recommended for the input capacitor. Use short and wide traces to minimize parasitic resistance and inductance. Inappropriate layout may result in large parasitic inductance and cause undesired oscillation between RT9199 and the preceding power converter.

Thermal Consideration

RT9199 regulators have internal thermal limiting circuitry designed to protect the device during overload conditions. For continued operation, do not exceed absolute maximum operation junction temperature 125°C. The power dissipation definition in device is:

$$P_D = (V_{IN} - V_{OUT}) \times I_{OUT} + V_{IN} \times I_Q$$

The maximum power dissipation depends on the thermal resistance of IC package, PCB layout, the rate of surroundings airflow and temperature difference between junction to ambient. The maximum power dissipation can be calculated by following formula:

$$P_{D(MAX)} = (T_{J(MAX)} - T_A) / \theta_{JA}$$

Where $T_{J(MAX)}$ is the maximum operation junction temperature 125°C , T_A is the ambient temperature and the θ_{JA} is the junction to ambient thermal resistance. The junction to ambient thermal resistance for SOP-8 package (Exposed Pad) is 86°C/W , on standard JEDEC 51-7 (4 layers, 2S2P) thermal test board. The maximum power dissipation at $T_A = 25^{\circ}\text{C}$ can be calculated by following formula:

$$P_{D(MAX)} = (125^{\circ}\text{C} - 25^{\circ}\text{C}) / 86^{\circ}\text{C/W} = 1.163\text{W}$$

Figure 8 shows the package sectional drawing of SOP-8 (Exposed Pad). Every package has several thermal dissipation paths. As show in Figure 9, the thermal resistance equivalent circuit of SOP-8 (Exposed Pad). The path 2 is the main path due to these materials thermal conductivity. We define the exposed pad is the case point of the path 2.

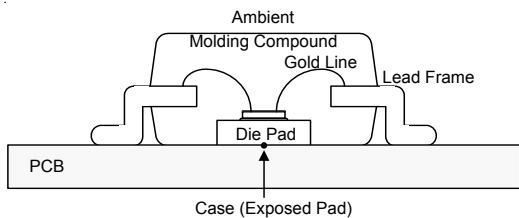

Figure 8. SOP-8 (Exposed Pad) Package Sectional Drawing

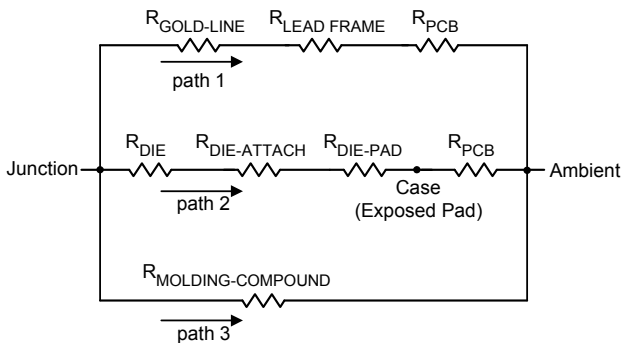

Figure 9. Thermal Resistance Equivalent Circuit

The thermal resistance θ_{JA} of SOP-8 (Exposed Pad) is determined by the package design and the PCB design. However, the package design has been decided. If possible, it's useful to increase thermal performance by the PCB design. The thermal resistance can be decreased by adding copper under the expose pad of SOP-8 package.

Figure 10 show the relation between thermal resistance θ_{JA} and copper area on a standard JEDEC 51-7 (4 layers, 2S2P) thermal test board at $T_A = 25^{\circ}\text{C}$. We have to consider the copper couldn't stretch infinitely and avoid the tin overflow. We use the "Dog-Bone" copper patterns on the top layer as Figure 11.

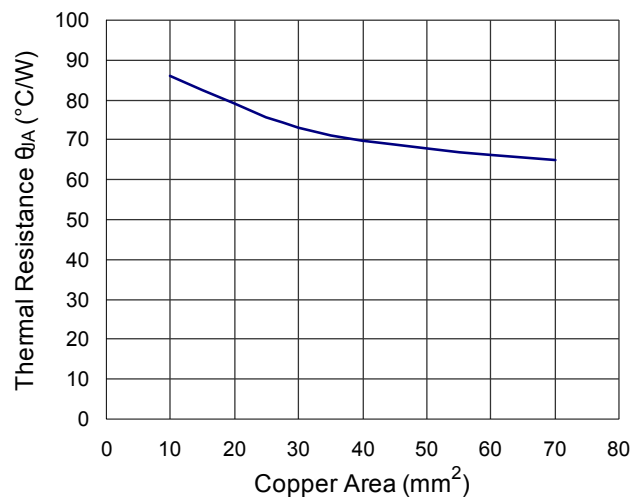

Figure 10. Relation Between Thermal Resistance θ_{JA} and Copper Area

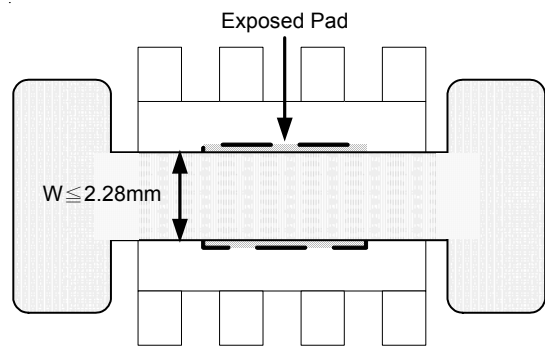
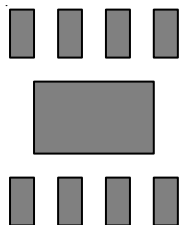
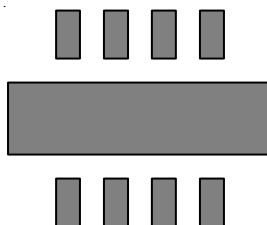

Figure 11. Dog-Bone Layout

As shown in Figure 12, the amount of copper area to which the SOP-8 (Exposed Pad) is mounted affects thermal performance. When mounted to the standard SOP-8 (Exposed Pad) pad of 2 oz. copper (Figure 12.a), θ_{JA} is 86°C/W. Adding copper area of pad under the SOP-8 (Exposed Pad) (Figure 12.b) reduces the θ_{JA} to 73°C/W. Even further, increasing the copper area of pad to 70mm² (Figure 12.d) reduces the θ_{JA} to 65°C/W.



(a) Copper Area = 10mm², θ_{JA} = 86°C/W



(b) Copper Area = 30mm², θ_{JA} = 73°C/W

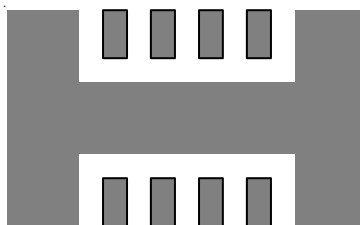

(c) Copper Area = 50mm², θ_{JA} = 68°C/W

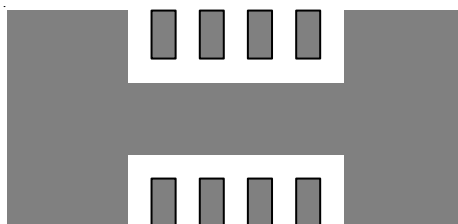

(d) Copper Area = 70mm², θ_{JA} = 65°C/W

Figure 12. Thermal Resistance vs. Copper Area Layout Thermal Design

Outline Information

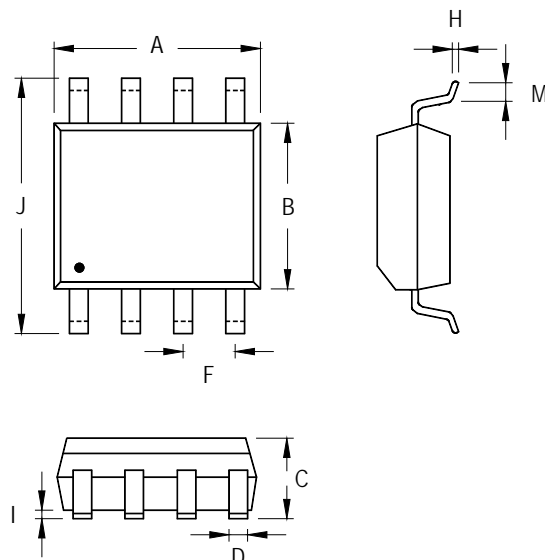

Symbol	Dimensions In Millimeters		Dimensions In Inches	
	Min	Max	Min	Max
A	4.801	5.004	0.189	0.197
B	3.810	3.988	0.150	0.157
C	1.346	1.753	0.053	0.069
D	0.330	0.508	0.013	0.020
F	1.194	1.346	0.047	0.053
H	0.170	0.254	0.007	0.010
I	0.050	0.254	0.002	0.010
J	5.791	6.200	0.228	0.244
M	0.400	1.270	0.016	0.050

8-Lead SOP Plastic Package

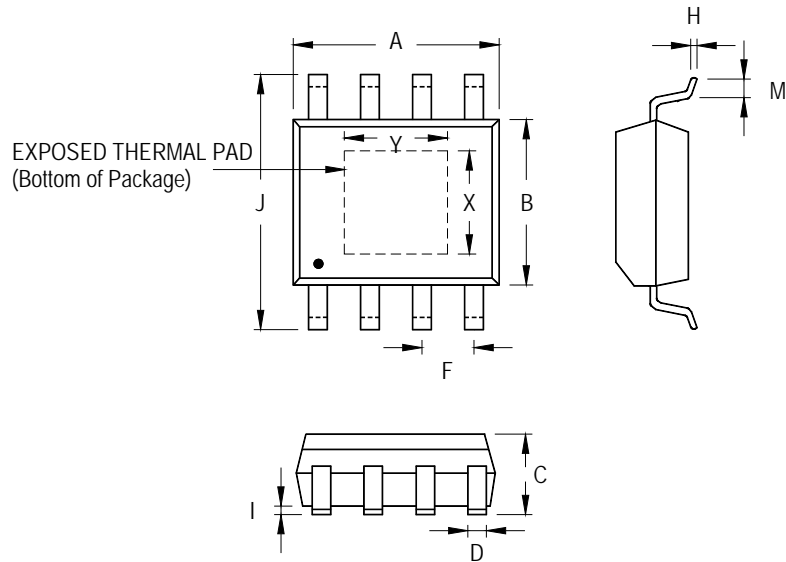

Symbol	Dimensions In Millimeters		Dimensions In Inches		
	Min	Max	Min	Max	
A	4.801	5.004	0.189	0.197	
B	3.810	4.000	0.150	0.157	
C	1.346	1.753	0.053	0.069	
D	0.330	0.510	0.013	0.020	
F	1.194	1.346	0.047	0.053	
H	0.170	0.254	0.007	0.010	
I	0.000	0.152	0.000	0.006	
J	5.791	6.200	0.228	0.244	
M	0.406	1.270	0.016	0.050	
Option 1	X	2.000	2.300	0.079	0.091
	Y	2.000	2.300	0.079	0.091
Option 2	X	2.100	2.500	0.083	0.098
	Y	3.000	3.500	0.118	0.138

8-Lead SOP (Exposed Pad) Plastic Package

Richtek Technology Corporation

Headquarter
 5F, No. 20, Taiyuen Street, Chupei City
 Hsinchu, Taiwan, R.O.C.
 Tel: (8863)5526789 Fax: (8863)5526611

Richtek Technology Corporation

Taipei Office (Marketing)
 8F, No. 137, Lane 235, Paochiao Road, Hsintien City
 Taipei County, Taiwan, R.O.C.
 Tel: (8862)89191466 Fax: (8862)89191465
 Email: marketing@richtek.com