



DATA SHEET

SD820CS~SD8100CS

SURFACE MOUNT SCHOTTKY BARRIER RECTIFIERS

VOLTAGE 20 to 100 Volts **CURRENT** 8 Amperes

TO-252 / DPAK Unit : inch (mm)

FEATURES

- For surface mounted applications
- Low power loss, High efficiency
- Built-in strain relief
- Easy pick and place
- High surge capacity
- Plastic package has Underwriters Laboratory Flammability Classification 94V-O
- For use in low voltage high frequency inverters, free wheeling, and polarity protection applications
- Both normal and Pb free product are available :
 - Normal : 80~95% Sn, 5~20% Pb
 - Pb free: 98.5% Sn above

MECHANICAL DATA

Case: D PAK/TO-252 molded plastic
 Terminals: Solder plated, solderable per MIL-STD-750, Method 2026
 Polarity: Color band denotes cathode
 Standard packaging: 16mm tape (EIA-481)
 Weight: 0.015 ounce, 0.4 gram.

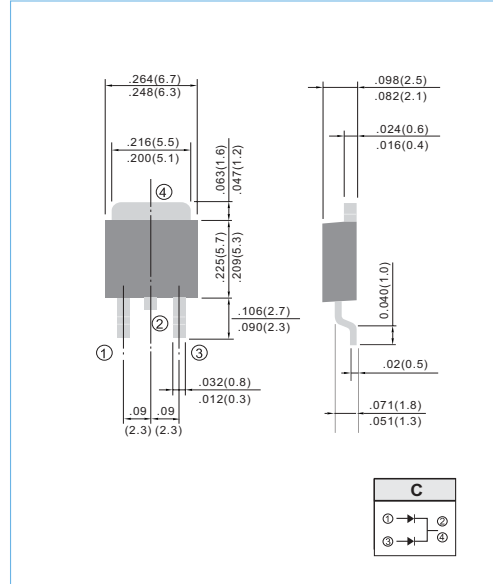

MAXIMUM RATINGS AND ELECTRICAL CHARACTERISTICS

Ratings at 25 °C ambient temperature unless otherwise specified. Single phase, half wave, 60 Hz, resistive or inductive load
 For capacitive load, derate current by 20%

PARAMETER	SYMBOL	SD820 CT	SD830 CT	SD840 CT	SD860 CT	SD880 CT	SD8100 CT	UNITS
Maximum Recurrent Peak Reverse Voltage	V _{RRM}	20	30	40	60	80	100	V
Maximum RMS Voltage	V _{RMS}	14	21	28	42	56	70	V
Maximum DC Blocking Voltage	V _{DC}	20	30	40	60	80	100	V
Maximum Average Forward Rectified Current .at T _c =85 °C	I _{AV}	8						A
Peak Forward Surge Current :8.3ms single half sine-wave superimposed on rated load(JEDEC method)	I _{FSM}	85						A
Maximum Instantaneous Forward Voltage at 4.0A (Note 1)	V _F	0.55			0.75	0.85		V
Maximum DC Reverse Current TC=25 °C at Rated DC Blocking Voltage TC=100 °C	I _R	0.2 20						mA
Maximum Thermal Resistance	R _{θJC} R _{θJA}	3.0 80						°C / W
Operating Junction and Storage Temperature Range	T _J , T _{STG}	-50 TO +125						°C



RATING AND CHARACTERISTIC CURVES

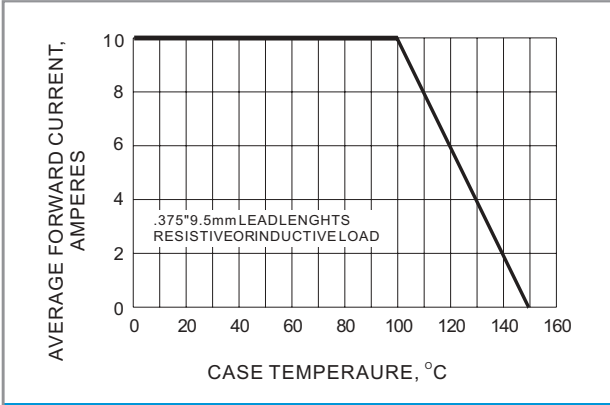

Fig.1- FORWARD CURRENT DERATING CURVE

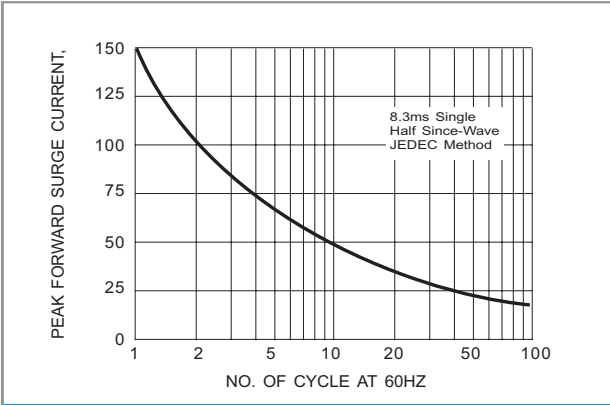

Fig.2- MAXIMUM NON-REPETITIVE SURGE CURRENT

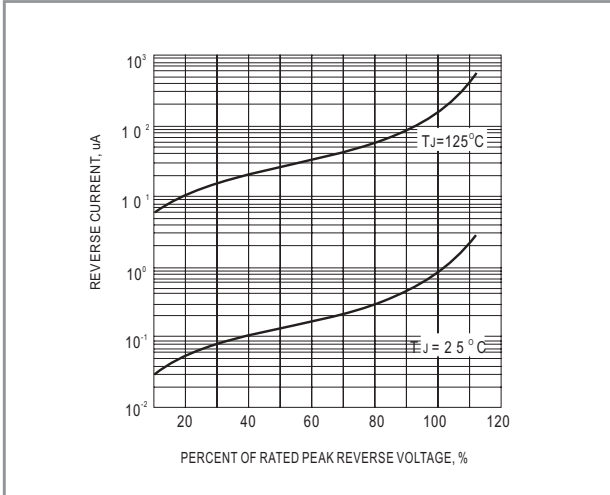

Fig.3- TYPICAL REVERSE CHARACTERISTIC

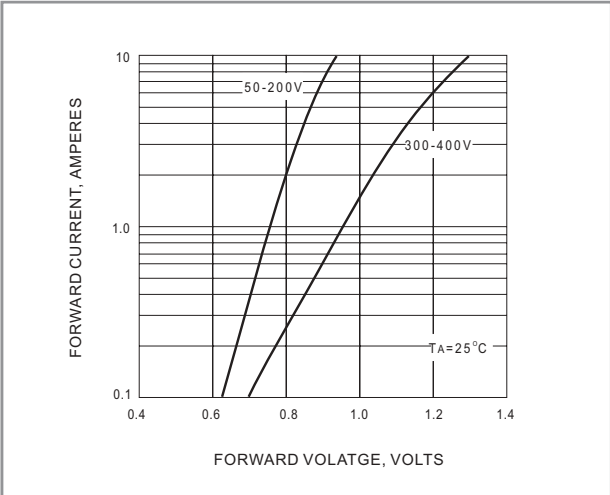

Fig.4- TYPICAL INSTANTANEOUS FORWARD CHARACTERISTIC