

TOSHIBA LED Lamps

TLWA1100 (T11)

Panel Circuit Indicator

- Surface-mount devices
- 3.2 (L) × 2.9 (W) × 1.9 (H) mm
- UV LED chip + RGB phosphor
- Luminous intensity : $I_v = 100$ mcd (typ.) @20mA
- Colors: White
- Chromaticity (typ.) : $C_x=0.33, C_y=0.32$
- $T_{opr} / T_{stg} = -40$ to 100°C
- Reflow soldering is possible
- Applications: automotive use, backlighting, etc.
- Standard embossed tape packing: T11 (2000/reel)
8-mm tape reel

Color and Material

Product Name	Color	Material
TLWA1100	White	GaN

Absolute Maximum Ratings ($T_a = 25^\circ\text{C}$)

Characteristics	Symbol	Rating	Unit
Forward Current (Note 1)	I_F	30	mA
Power Dissipation	P_D	126	mW
Operating Temperature	T_{opr}	-40~100	$^\circ\text{C}$
Storage Temperature	T_{stg}	-40~100	$^\circ\text{C}$

Note: Using continuously under heavy loads (e.g. the application of high temperature/current/voltage and the significant change in temperature, etc.) may cause this product to decrease in the reliability significantly even if the operating conditions (i.e. operating temperature/current/voltage, etc.) are within the absolute maximum ratings.

Please design the appropriate reliability upon reviewing the Toshiba Semiconductor Reliability Handbook ("Handling Precautions"/"Derating Concept and Methods") and individual reliability data (i.e. reliability test report and estimated failure rate, etc).

Note 1: Forward current derating

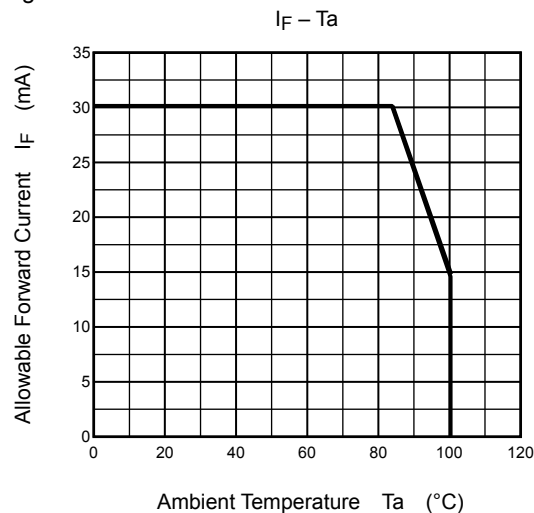

Unit: mm

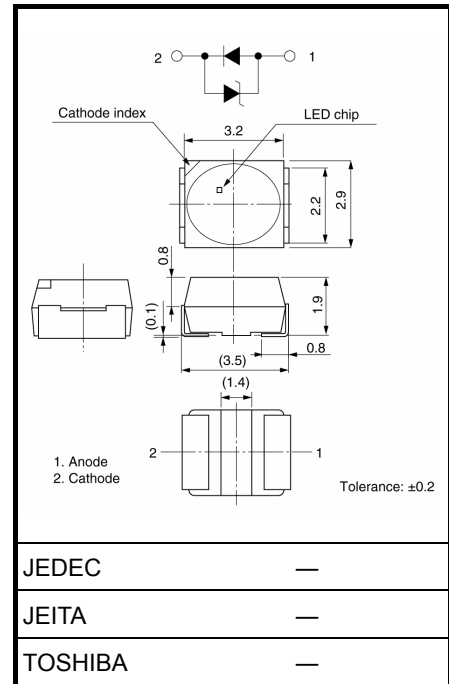

Weight: 0.035 g (typ.)

Electrical Characteristics (Ta = 25°C)

Characteristics	Symbol	Test condition	Min.	Typ.	Max.	Unit
Forward Voltage	V_F	$I_F = 20 \text{ mA}$	—	3.5	4.2	V
Reverse Voltage	V_R	$I_R = 10 \text{ mA}$	—	0.75	—	V

Optical Characteristics (Ta = 25°C)

Characteristics	Symbol	Test condition	Min.	Typ.	Max.	Unit
Chromaticity	C_x	$I_F = 20 \text{ mA}$	(Note 2)			—
	C_y	$I_F = 20 \text{ mA}$	(Note 2)			—
Luminous Intensity (Note 3)	I_V	$I_F = 20 \text{ mA}$	63	100	200	mcd

Note 2: The product is tested at the following chromaticity coordinate groups.

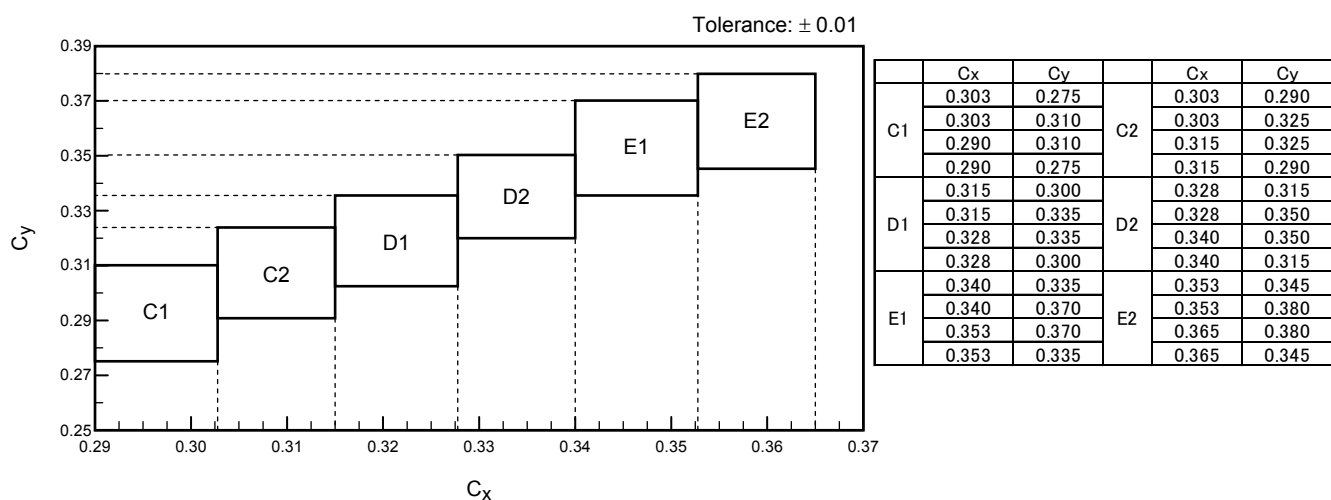

Note 3: I_V rank classification

Test conditions: $I_F=20\text{mA}$, $T_a=25^\circ\text{C}$

Product name	Luminous intensity I_V			
	min	typ	max	I_F
TLWA1100(T11)	63	100	200	20
QA	63	—	125	
RA	100	—	200	
Unit	mcd			mA

The specification on the above table is used for I_V classification of LEDs in Toshiba facility. Each reel includes the same rank LEDs. Let the delivery ratio of each rank be unquestioned.

Note 4: Ultraviolet light luminescence

This white LED lamp also emits some UV light. (Around 360~400nm)

When this LED lamp is used for general indicator, it is no problem. However the LED is not recommended for the following applications.

(1) Prohibition

- Human eye is damaged by the condensed light. (Ex. microscope, outer lens, etc)

(2) Notice

- LED is located at near a skin (the distance is less than 20mm), and exposure time is more than 60 min.

- Photosensitive material is used with this LED in a set. It might be damaged by the light.

Note 5: Do not break, cut or pulverize the product.

Note 6: This product is designed as a general display light source usage, and it has applied the measurement standard that matched with the sensitivity of human's eyes. Therefore, it is not intended for usage of functional application (ex. Light source for sensor, optical communication and etc) except general display light source.

TLWA1100

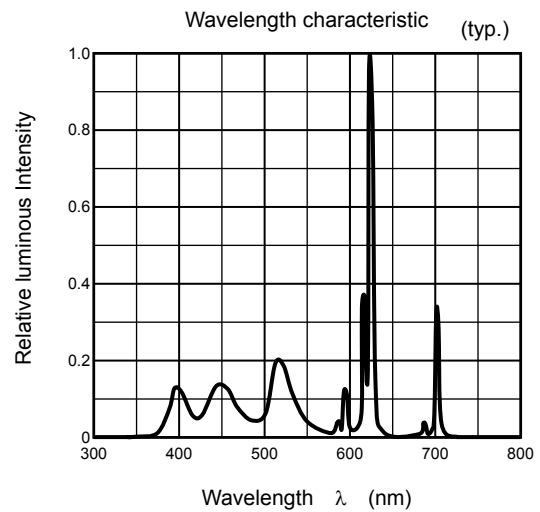
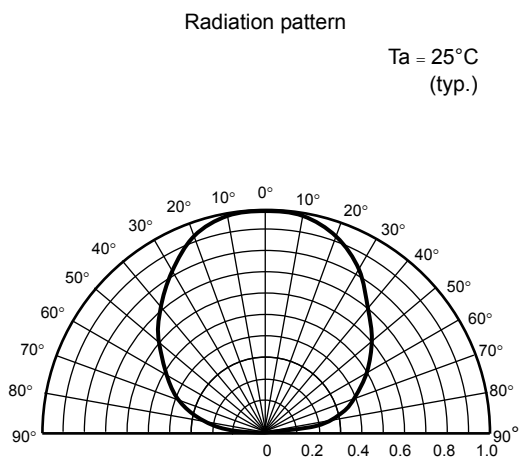
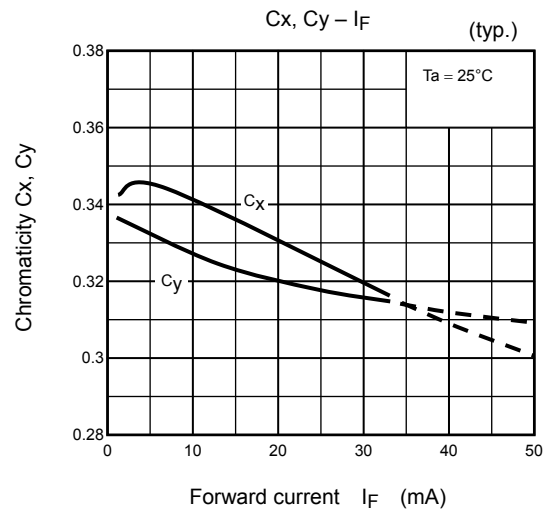
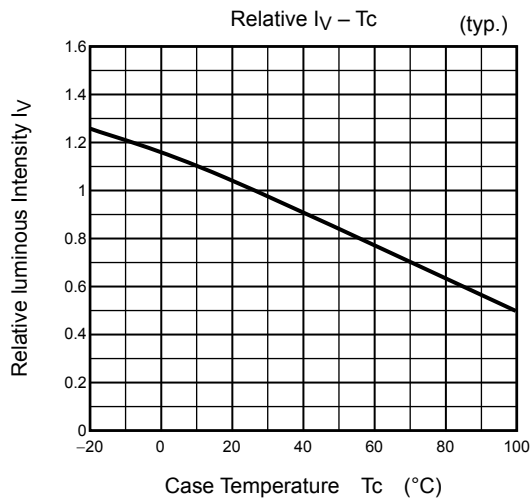
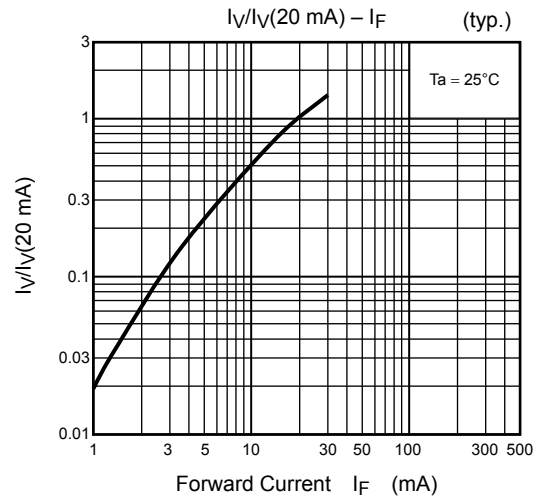
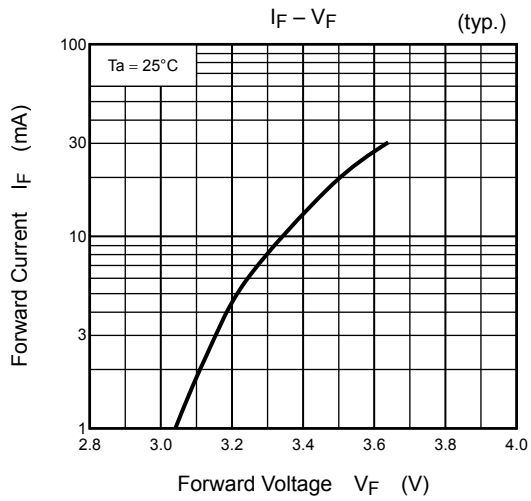

Packaging

These LED devices are packed in an aluminum envelope with silica gel and a moisture indicator to prevent moisture absorption. The optical characteristics of the devices may be affected by exposure to moisture in the air before soldering and they should therefore be stored under the following conditions:

1. This moisture proof bag may be stored unopened for up to 12 months under the following conditions.
 Temperature: 5°C~30°C
 Humidity: 90% (max)
2. After the moisture proof bag has been opened, the devices should be assembled within 168 hours in an environment of 5°C to 30°C/60% RH or below.
3. If, upon opening, the moisture indicator card shows humidity of 30% or above (when the indication color changes to pink) or the expiration date has passed, the devices should be baked while packed in the tape reel. After baking, use the baked devices within 72 hours, but perform baking only once.
 Baking conditions: 60±5°C, for 12 to 24 hours.
 Expiration date: 12 months from sealing date, which is imprinted on the same side as this label affixed.
4. Repeated baking may cause the peeling strength of the tape to change, leading to trouble in mounting. Also, be sure to prevent damage to the device from static electricity during the baking process.
5. Any breakage in the laminate packing material will cause the hermeticity of the product to deteriorate. Do not toss or drop the packed devices.

Mounting Method

Soldering

- Reflow soldering

Temperature profile (example)

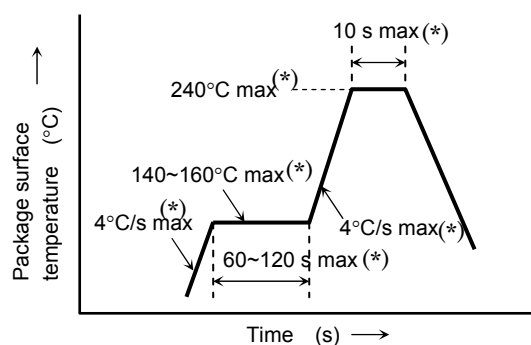

- The product is evaluated using above reflow soldering conditions. No additional test is performed exceed the condition (i.e. the condition more than (*)MAX values) as a evaluation. Please perform reflow soldering under the above conditions.
- Please perform the first reflow soldering with reference to the above temperature profile and within 168 h of opening the package.
- Second reflow soldering
 In case of second reflow soldering should be performed within 168 h of the first reflow under the above conditions.
 Storage conditions before the second reflow soldering: 30°C, 60% RH (max)
- Make any necessary soldering corrections manually.
 (only once at each soldering point)
 Soldering iron : 25 W
 Temperature : 300°C or less
 Time : within 3 s
- If the product needs to be performed by other soldering method (ex. wave soldering), please contact Toshiba sales representative.

Recommended soldering pattern

Unit: mm

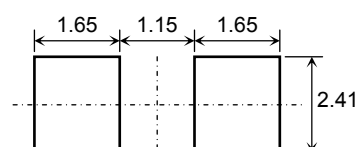

Cleaning

When cleaning is required after soldering, Toshiba recommends the following cleaning solvents. It is confirmed that these solvents have no effect on semiconductor devices in our dipping test (under the recommended conditions). In selecting the one for your actual usage, please perform sufficient review on washing condition, using condition and etc.

ASAHI CLEAN AK-225AES	: (made by ASAHI GLASS)
KAO CLEAN TROUGH 750H	: (made by KAO)
PINE ALPHA ST-100S	: (made by ARAKAWA CHEMICAL)
TOSHIBA TECHNOCARE (FRW-17, FRW-1, FRV-100)	: (made by GE TOSHIBA SILICONES)

Precautions when Mounting

Do not apply force to the plastic part of the LED under high-temperature conditions.

To avoid damaging the LED plastic, do not apply friction using a hard material.

When installing the PCB in a product, ensure that the device does not come into contact with other components.

Tape Specifications

1. Product number format

The type of package used for shipment is denoted by a symbol suffix after the product number. The method of classification is as below. (This method, however, does not apply to products whose electrical characteristics differ from standard Toshiba specifications.)

- (1) Tape Type: T11 (4-mm pitch)
- (2) Example

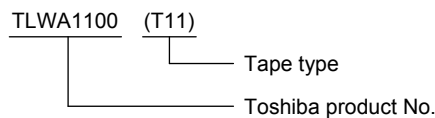

2. Tape dimensions

Unit: mm

Symbol	Dimension	Tolerance
D	1.5	+0.1/-0
E	1.75	±0.1
P ₀	4.0	±0.1
t	0.3	±0.05
F	3.5	±0.05
D ₁	1.5	±0.1

Symbol	Dimension	Tolerance
P ₂	2.0	±0.05
W	8.0	±0.3
P	4.0	±0.1
A ₀	2.9	±0.1
B ₀	3.7	±0.1
K ₀	2.3	±0.1

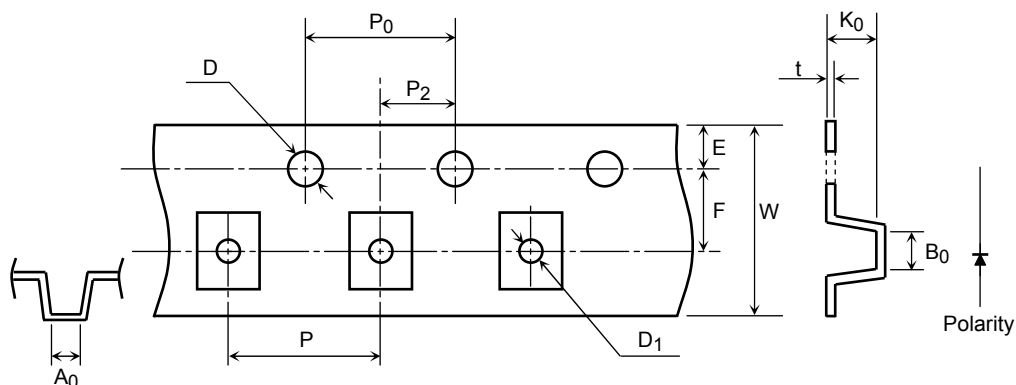

3. Reel dimensions

Unit: mm

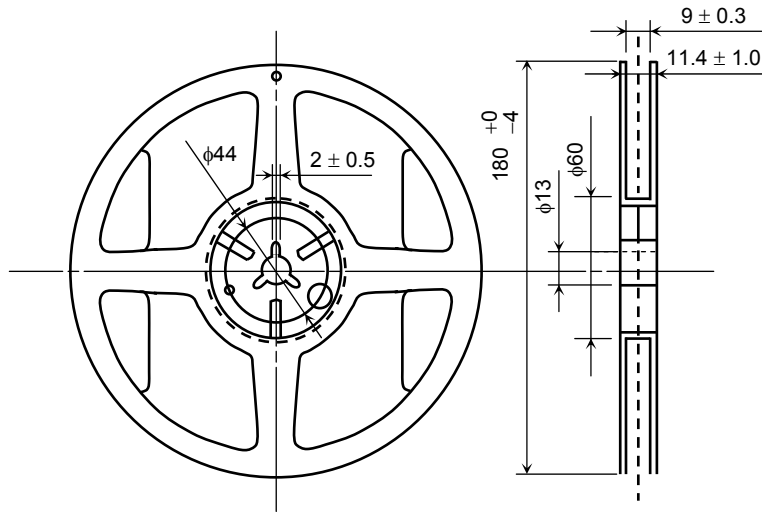

4. Leader and trailer sections of tape

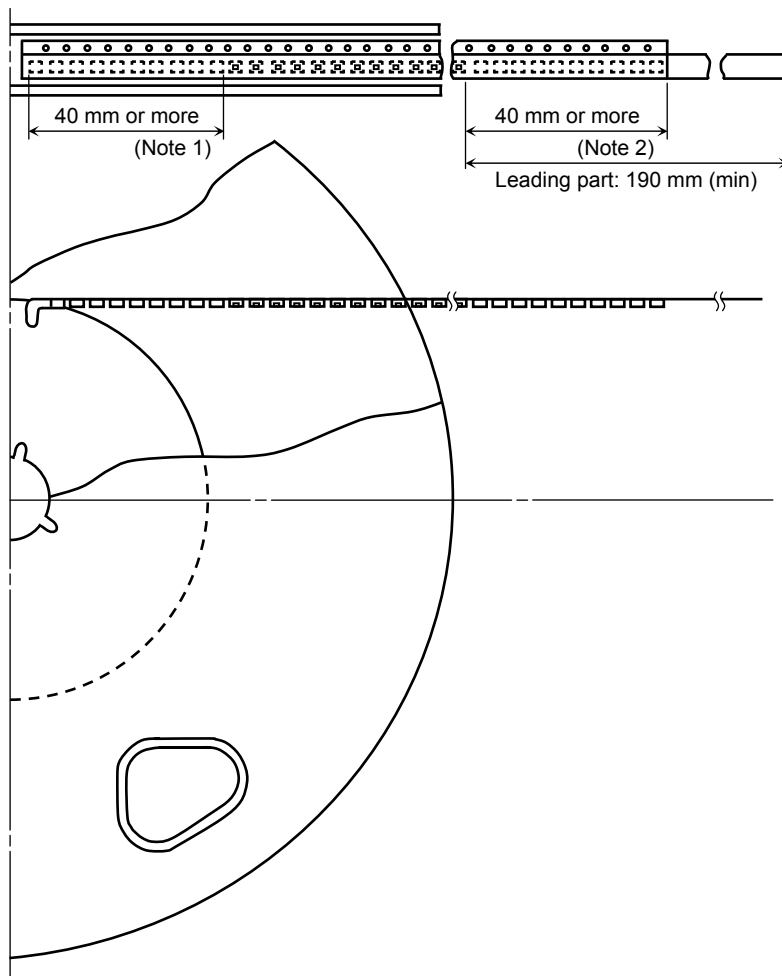

Note1: Empty trailer section

Note2: Empty leader section

5. Packing display

(1) Packing quantity

Reel	2,000 pcs
Carton	10,000 pcs

(2) Packing form: Each reel is sealed in an aluminum pack with silica gel.

6. Label format

(1) Example: TLWA1100 (T11)

P/N:				TOSHIBA 
TYPE	TLWA1100			
ADDC	(T11)	Q'TY	2,000 pcs	

Lot Number Key code for TSB 32C 2000
 (RANK SYMBOL)

Use under 5-30degC/60%RH within 168h

[[G]]/RoHS COMPATIBLE *Y3804xxxxxxxxxxxxxxxxxxxx*	SEAL DATE: ***** DIFFUSED IN ***** ASSEMBLED IN *****
--	---



(2) Label location

• Reel

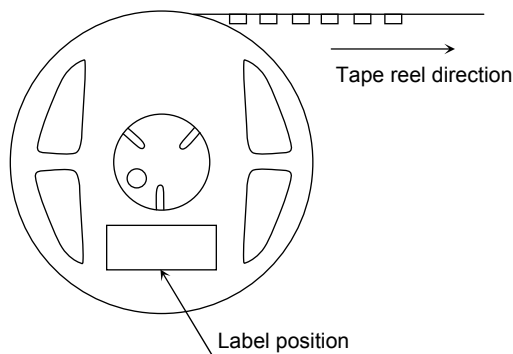

• Carton

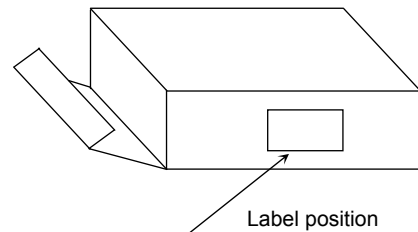

• The aluminum package in which the reel is supplied also has a copy of the label attached to the center of one side.

RESTRICTIONS ON PRODUCT USE

20070701-EN GENERAL

- The information contained herein is subject to change without notice.
- TOSHIBA is continually working to improve the quality and reliability of its products. Nevertheless, semiconductor devices in general can malfunction or fail due to their inherent electrical sensitivity and vulnerability to physical stress. It is the responsibility of the buyer, when utilizing TOSHIBA products, to comply with the standards of safety in making a safe design for the entire system, and to avoid situations in which a malfunction or failure of such TOSHIBA products could cause loss of human life, bodily injury or damage to property.
In developing your designs, please ensure that TOSHIBA products are used within specified operating ranges as set forth in the most recent TOSHIBA products specifications. Also, please keep in mind the precautions and conditions set forth in the "Handling Guide for Semiconductor Devices," or "TOSHIBA Semiconductor Reliability Handbook" etc.
- The TOSHIBA products listed in this document are intended for usage in general electronics applications (computer, personal equipment, office equipment, measuring equipment, industrial robotics, domestic appliances, etc.). These TOSHIBA products are neither intended nor warranted for usage in equipment that requires extraordinarily high quality and/or reliability or a malfunction or failure of which may cause loss of human life or bodily injury ("Unintended Usage"). Unintended Usage include atomic energy control instruments, airplane or spaceship instruments, transportation instruments, traffic signal instruments, combustion control instruments, medical instruments, all types of safety devices, etc.. Unintended Usage of TOSHIBA products listed in this document shall be made at the customer's own risk.
- The products described in this document shall not be used or embedded to any downstream products of which manufacture, use and/or sale are prohibited under any applicable laws and regulations.
- The information contained herein is presented only as a guide for the applications of our products. No responsibility is assumed by TOSHIBA for any infringements of patents or other rights of the third parties which may result from its use. No license is granted by implication or otherwise under any patents or other rights of TOSHIBA or the third parties.
- Please contact your sales representative for product-by-product details in this document regarding RoHS compatibility. Please use these products in this document in compliance with all applicable laws and regulations that regulate the inclusion or use of controlled substances. Toshiba assumes no liability for damage or losses occurring as a result of noncompliance with applicable laws and regulations.