

General Description

The AQ120 is a low cost linear battery charger controller with similar features to the industry standard “1734” style controller, but with the extra ability to charge multiple cell Lithium Ion batteries as well as NiCad types. In addition, the maximum V_{in} is 18 volts. The AQ120 flexibility allows the setting of the charge voltage and current with a minimum number of external components.

The open collector output is capable of driving an external PNP transistor. A temperature stable bandgap reference (1.25 V) controls the maximum output voltage, while a current control circuit sets a constant charging current.

Applications

- Battery chargers

Features

- 1.25V reference with 1% accuracy
- Multiple cell compatible
- Programmable charge current
- Low current consumption
- Offered in ultra small SC70-5 package
- No blocking diode required
- Wide V_{in} range: 2.5V to 18V
- 25mA drive current sink
- No battery drain in shutdown
- Sleep mode with input supply removal
- **RoHS compliant** available

Block Diagram

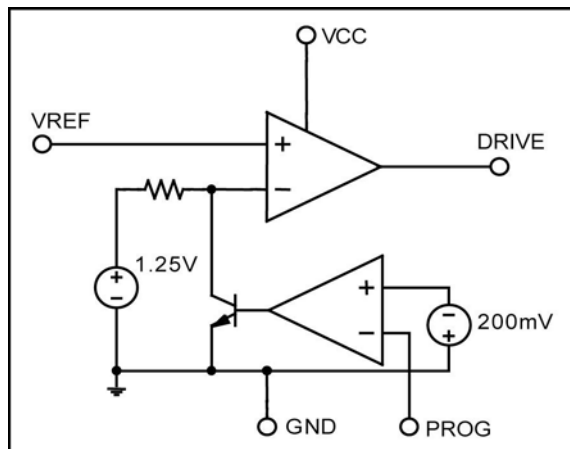

Pin Configuration

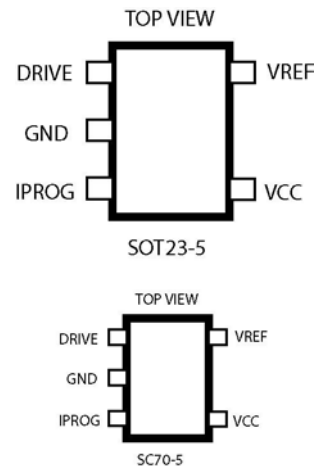

Typical Application

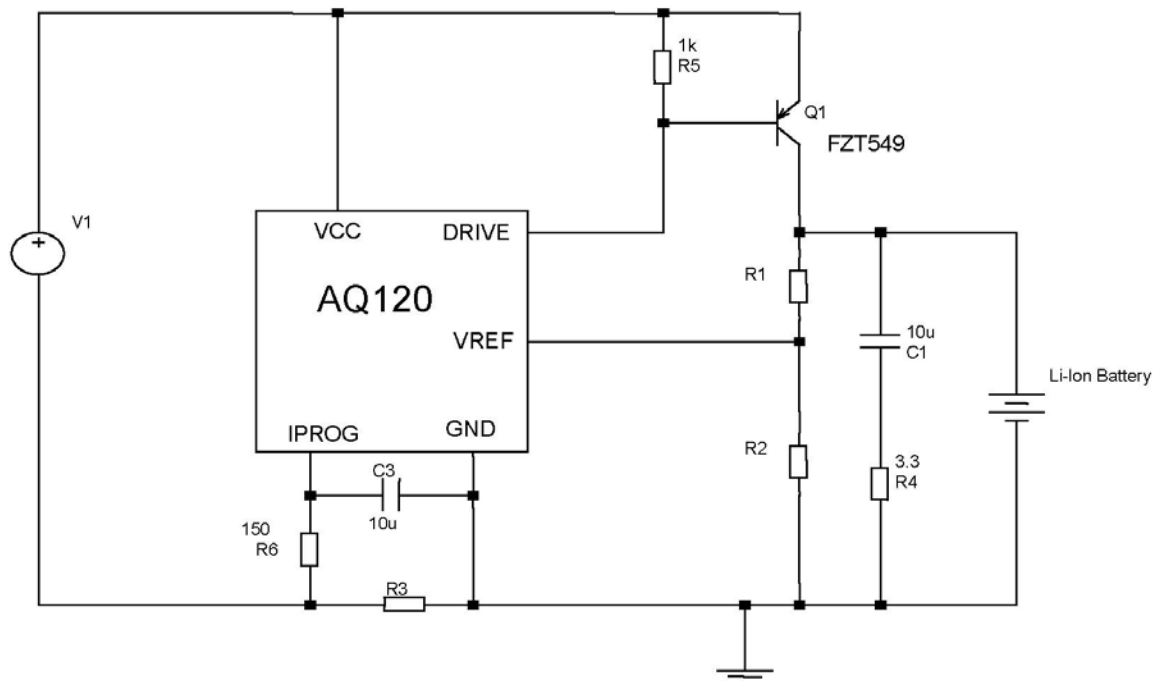

Note: The values of R1 and R2 set the charge voltage (up to three Li-Ion cells is possible). The value of R3 sets the charge current.

Pin Descriptions

Pin	Pin Name	Function
1	DRIVE	Output of error amplifier. 25 mA sink capability
2	GND	Ground
3	Iprog	Current programming pin, has a threshold of 200 mV.
4	VCC	Positive supply
5	VREF	Voltage programming pin; has a threshold of 1.25V.

Ordering Information

Device	Operating Tj	%Tol	Pkg Type	Vout	Wrap	Order Number
AQ120	-20°C ≤ 105°C	1.0	SOT-23-5	1.25V	T&R	AQ120DY-M5-AJ-TR
AQ120	-20°C ≤ 105°C	1.0	SOT-23-5	1.25V	T&R	AQ120DY-M5-AJ-TRL
AQ120	-20°C ≤ 105°C	1.0	SC70-5	1.25V	T&R	AQ120DY-C5-AJ-TR
AQ120	-20°C ≤ 105°C	1.0	SC70-5	1.25V	T&R	AQ120DY-C5-AJ-TRL

Note: The TRL parts are Lead Free and RoHS compliant.

Absolute Maximum Ratings

Parameter	Value	Units
V _{CC} Voltage	18	V
DRIVE Voltage	18	V
REF Voltage	18	V
V _{CC} , DRIVE, REF Current	50	mA
Operating Junction Temperature	150	°C
Lead Temperature (soldering 10 seconds)	300	°C
Storage Temperature Range	-80 to +150	°C

Electrical Specifications

Electrical characteristics are guaranteed over the full temperature range $-20^{\circ}\text{C} < T_j < 105^{\circ}\text{C}$. Ambient temperature must be de-rated based upon power dissipation and package thermal characteristics. Unless otherwise stated, test conditions are V_{CC} = 5V, V_{DRIVE} = 4.3V, V_{I_{PROG}} = 0V.

Symbol	Parameter	Conditions	Min	Typ	Max	Units
V _{CC}	Supply Voltage Range		2.5	5	18	V
I _{CC}	V _{CC} Quiescent Supply Current	V _{REF} = V _{CC} = V _{DRIVE} = 5V		150	300	μA
V _{REF}	Reference Voltage	T _a = 25°C	1.238	1.250	1.263	V
TC _{REF}	Reference Temperature Deviation	-20°C < T _j < 105°C		0.5	1	%
L _{nREG}	Reference variation with Supply Voltage	V _{CC} = 2.5V to 18V I _{DRIVE} = 500 μA		0.3	0.6	mV/V
I _{REF}	Reference input current	V _{REF} = 0V	-50	-20		nA
V _{DRVLOW}	Output Saturation Voltage	I _{DRIVE} = 10 mA, V _{REF} = 0V		1.8	2.2	V
I _{DRIVE}	Drive Current	V _{DRIVE} = 5V, V _{REF} = V _{I_{PROG}} = GND	20	25		mA
I _{LEAK}	Output Leakage Current	V _{DRIVE} = V _{REF} = V _{CC} = 18V		200	400	nA
V _{I_{PROG}}	I _{PROG} threshold voltage	T _j = 25°C -20 < T _j < 105°C	190 195	200 200	210 205	mV
Gain	Delta V _{ref} / V _{I_{PROG}}	T = 25°C -20 < T _j < 105°C	36	40 40	44	mV/ mV
I _{I_{PROG}}	I _{PROG} input current	V _{I_{PROG}} = 0V V _{I_{PROG}} = -250 mV		-50 -160		μA

Typical Performance Characteristics

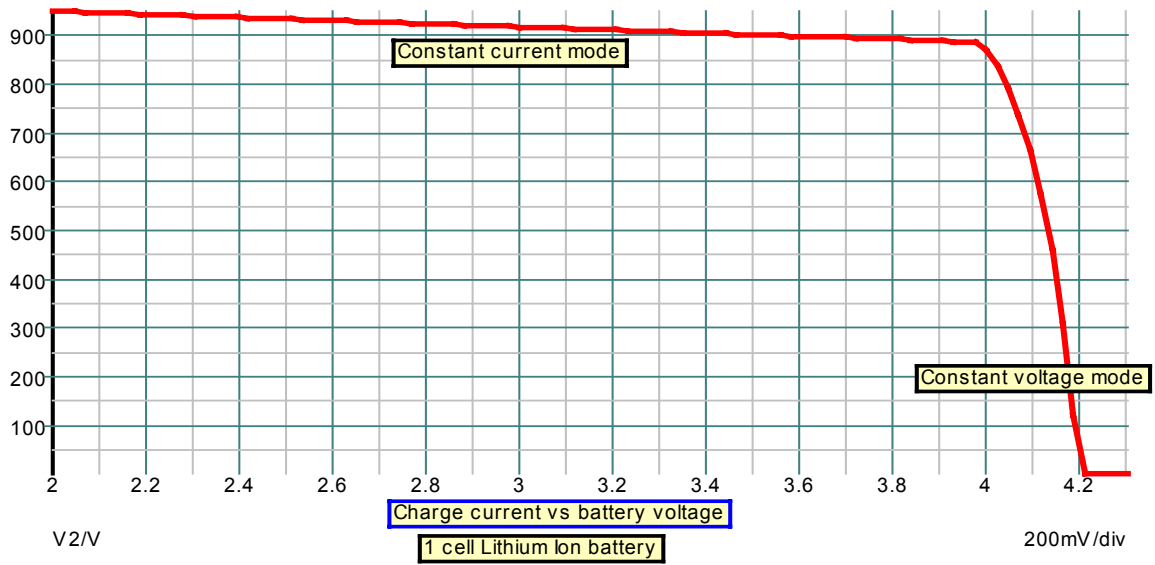

Fig.1 Charge current vs battery voltage



Fig. 2 Battery charge vs time

Operation

The AQ120 is a linear battery charger controller. Charging begins when V_{cc} rises above 2.5V. When charging, the collector of the external PNP transistor provides the charge current.

Below the target charge voltage the controller is in current mode. When the battery voltage reaches the target voltage then the controller switches to the voltage mode. The target voltage is programmable through an external resistor divider. This allows flexibility to set the voltage (to one or more cells Li ion batteries, NiMH or NiCd batteries).

In current mode the AQ120 regulates the voltage across the sense resistor to be 200 mV. The charge current is therefore given by $I_{ch} = 0.2V / R_{sense}$. An additional resistor is recommended (as in the typical application diagram) for stability reasons, then the threshold is actually increased by the value of the resistor multiplied by the current out of the IPROG pin. The AQ120 is designed for a maximum current in excess of 1A. The external PNP transistor must have adequate beta, low saturation voltage and sufficient power dissipation capability. With low supply voltages, the PNP saturation voltage becomes important as well.

In constant voltage mode, the controller will control the battery voltage not to exceed the target charge voltage.

When V_{cc} is applied, the charger can be manually shut down by opening the resistor R2 of the resistor divider (floating the otherwise grounded end of R2) or by pulling high the REF pin. This can be used in conjunction with an external thermostat switch.

When input power is removed or manual shutdown is entered, the charger will drain only very small leakage currents from the battery, thus maximizing battery standby time. The leakage current is due to the reverse-biased base-emitter junction of the external PNP transistor.

A LED indicator can be added to show when the charger is operational, simply connecting the base-emitter of an additional PNP transistor in parallel to the base-emitter of Q1 and its collector to the LED.

The AQ120 contains two control loops. To maintain good AC stability in the constant voltage mode, a capacitor of at least 10uF in series to a 3.3 ohms resistor is usually required from the collector of the external PNP to ground. The stability of the system is also depending on the type of external PNP transistor. High beta PNPs may be reducing the phase margin in some cases. R6 and C3 insure system stability in current mode without affecting the voltage mode. The use of the resistor R6 affects the threshold. For example for R6=150 ohms the threshold moves from 200 mV to 215 mV.

Furthermore the use of an external PMOS in place of the PNP represents a valid alternative to the application when wanting to minimize the current consumption during charge.

Package Dimensions

SOT23-3, SOT23-4, SOT23-5, SOT23-6

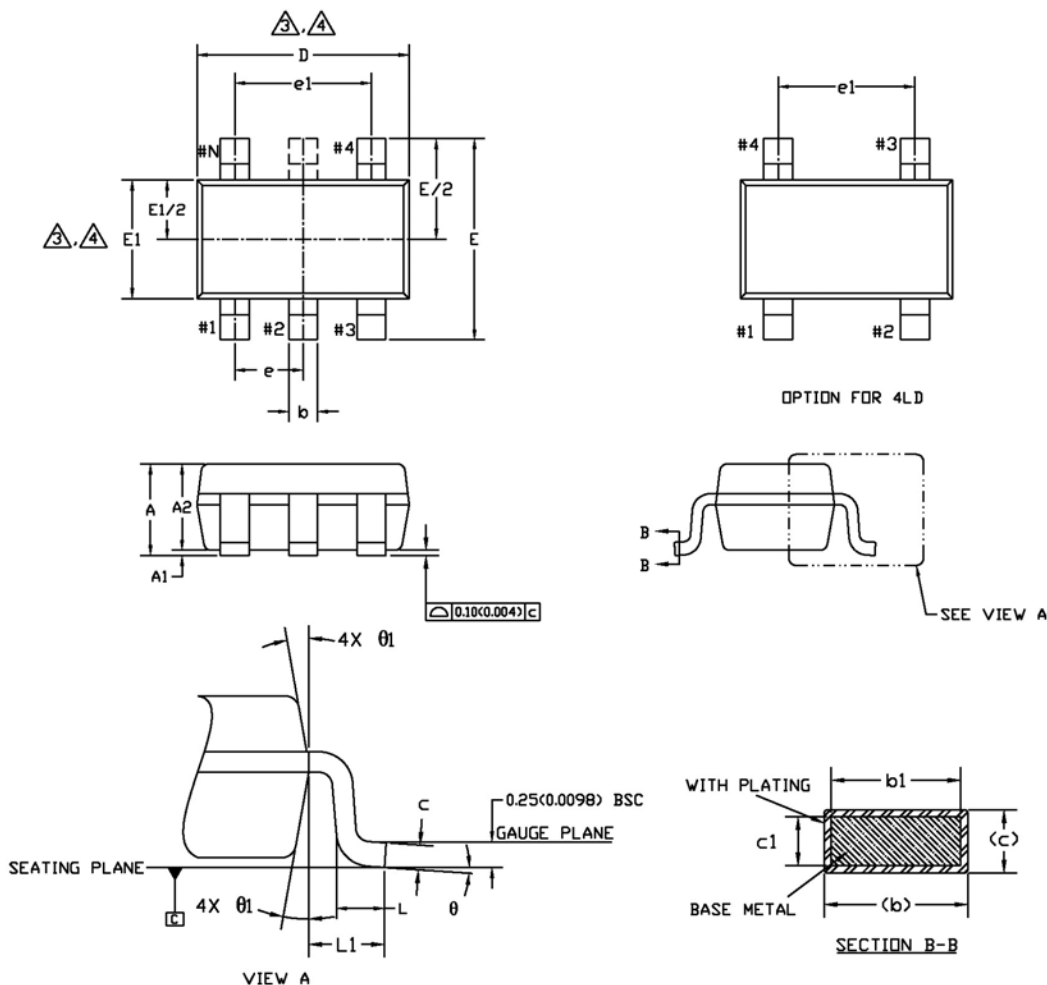

SYMBOL	COMMON					
	DIMENSIONS MILLIMETER			DIMENSIONS INCH		
	MIN.	NDM.	MAX.	MIN.	NDM.	MAX.
A	1.20	1.30	1.40	0.047	0.051	0.055
A1	0.05	-	0.15	0.002	-	0.006
A2	0.90	1.15	1.30	0.035	0.045	0.051
b	0.35	-	0.50	0.013	-	0.020
b1	0.35	0.40	0.45	0.013	0.015	0.017
c	0.08	-	0.22	0.003	-	0.008
c1	0.08	0.13	0.20	0.003	0.005	0.007
D	2.90 BSC			0.114 BSC		
E	2.80 BSC			0.110 BSC		
E1	1.60 BSC			0.062 BSC		
e	0.95 BSC			0.037 BSC		
e1	1.90 BSC			0.074 BSC		
L	0.35	0.45	0.55	0.013	0.017	0.021
L1	0.60 REF.			0.023 REF.		
θ	0°	4°	8°	0°	4°	8°
θ1	10° TYP			10° TYP		

NOTE :

1. Dimensioning and tolerancing per ASME Y 14.5 M - 1994.
2. Dimensions are in millimeters. Converted inch dimension are not necessarily exact.
3. Dimension D does not include mold flash, protrusions or gate burrs. Mold flash, protrusion or gate burrs shall not exceed 0.15 mm per side. Dimension E1 does not include interlead flash or protrusion. Interlead flash or protrusion shall not exceed 0.15 mm per side.
4. Top package may be smaller than the bottom package. Dimension D and E1 are determine at the outermost extremes of the plastic body exclusive of mold flash gate burrs and interlead flash.
5. Terminal numbers are shown for reference only. Die is facing up for molding. Die is facing down for trim/form.

SC70-3, SC70-4, SC70-5, SC70-6

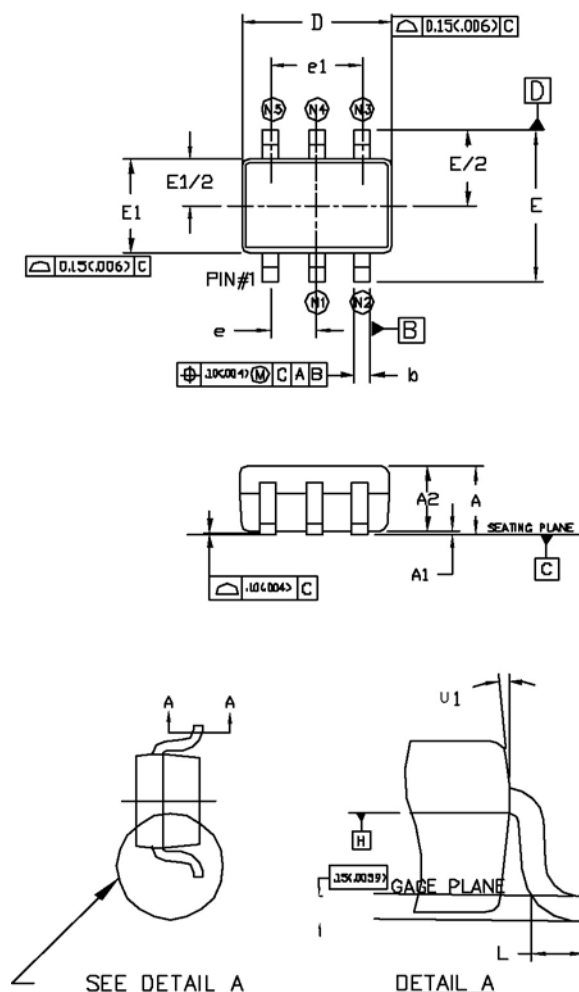

- NOTE :
1. CONTROLLING DIMENSION : MILLIMETER. CONVERTED INCH DIMENSION ARE NOT NECESSARILY EXACT.
 2. DIMENSIONING AND TOLERANCING PER ANSI Y14.5M-1994.
 3. DIMENSION "D" DOES NOT INCLUDE MOLD FLASH, PROTRUSION OR GATE BURR, MOLD FLASH, PROTRUSION OR GATE BURR SHALL NOT EXCEED 0.15MM(0.006") PER END. DIMENSION E1 DO NOT INCLUDE INTER-LEAD FLASH OR PROTRUSION, INTER-LEAD FLASH OR PROTRUSION SHALL NOT EXCEED 0.15MM (0.006") PER SIDE.
 4. THE PACKAGE TOP BE SMALLER THAN THE PACKAGE BOTTOM. DIMENSION D AND E1 ARE DETERMINED AT THE OUTERMOST EXTREMES OF THE PLASTIC BODY EXCLUSIVE OF MOLD FLASH, TIE BAR BURRS, GATE BURRS AND INTERLEAD FLASH, BUT INCLUDING ANY MISMATCH BETWEEN THE TOP AND BOTTOM OF THE PLASTIC BODY

SYMBOL	COMMON					
	DIMENSIONS MILLIMETER			DIMENSIONS INCH		
	MIN.	NOM.	MAX.	MIN.	NOM.	MAX.
A	0.80	-	1.10	0.031	-	0.043
A1	0	-	0.10	0	-	0.004
A2	0.80	0.90	1.00	0.031	0.035	0.040
b	0.15	-	0.30	0.006	-	0.012
b1	0.15	0.20	0.25	0.006	0.008	0.010
c	0.08	-	0.25	0.003	-	0.010
c1	0.08	0.13	0.20	0.003	0.005	0.008
D	1.90	2.10	2.15	0.074	0.082	0.084
E	2.00	2.10	2.20	0.078	0.082	0.086
E1	1.15	1.25	1.35	0.045	0.050	0.055
e	0.65 BSC			0.0255 BSC		
e1	1.30 BSC			0.0512 BSC		
L	0.26	0.36	0.46	0.010	0.014	0.018
U	0°	-	8°	0°	-	8°
U1	4°	-	10°	4°	-	10°

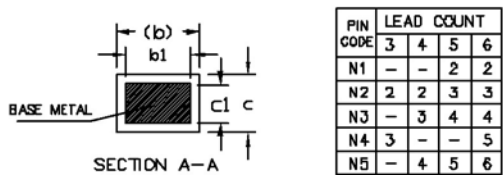

PIN CODE	LEAD COUNT					
	3	4	5	6		
N1	-	-	2	2		
N2	2	2	3	3		
N3	-	3	4	4		
N4	3	-	-	5		
N5	-	4	5	6		

Contact Information

Acutechnology Semiconductor Inc.
 3487 McKee Rd. Suite 52
 San Jose CA , USA 95127

TEL: (408) 259-2300
 FAX: (408) 259-9160
 website: www.acutechnology.com

Disclaimer

The information furnished by Acutechnology in this data sheet is believed to be accurate and reliable. However, Acutechnology assumes no responsibility for its use. Acutechnology reserves the right to change circuitry and specifications at any time without notification to the customer.

Life Support Policy

Acutechnology Products are not designed or authorized for use as components in life support devices or systems where malfunction of a product can reasonably be expected to result in personal injury. Life support devices or systems are devices or systems that (a) are intended for surgical implant into the body or (b) support or sustain life, and whose failure to perform can be reasonably expected to result in a significant injury to the user.