

## GENERAL DESCRIPTION



The ICS9DB202 is a high performance 1-to-2 Differential-to-HCSL Jitter Attenuator designed for use in PCI Express™ systems. In some PCI Express™ systems, such as those found in desktop PCs, the PCI Express™ clocks are generated from a low bandwidth, high phase noise PLL frequency synthesizer. In these systems, a jitter-attenuating device may be necessary in order to reduce high frequency random and deterministic jitter components from the PLL synthesizer and from the system board. The ICS9DB202 has two PLL bandwidth modes. In low bandwidth mode, the PLL loop bandwidth is 500kHz. This setting offers the best jitter attenuation and is still high enough to pass a triangular input spread spectrum profile. In high bandwidth mode, the PLL bandwidth is at 1MHz and allows the PLL to pass more spread spectrum modulation.

For serdes which have x10 reference multipliers instead of x12.5 multipliers, each of the two PCI Express™ outputs (PCIEX0:1) can be set for 125MHz instead of 100MHz by configuring the appropriate frequency select pins (FS0:1).

## FEATURES

- Two 0.7V current mode differential HCSL output pairs
- One differential clock input
- CLK and nCLK supports the following input types: LVPECL, LVDS, LVHSTL, SSTL, HCSL
- Maximum output frequency: 140MHz
- Input frequency range: 90MHz - 140MHz
- VCO range: 450MHz - 700MHz
- Output skew: 110ps (maximum)
- Cycle-to-cycle jitter: 110ps (maximum)
- RMS phase jitter @ 100MHz, (1.5MHz - 22MHz): 2.42ps (typical)
- 3.3V operating supply
- 0°C to 70°C ambient operating temperature
- Available in both standard and lead-free RoHS compliant packages
- Industrial temperature information available upon request

## BLOCK DIAGRAM

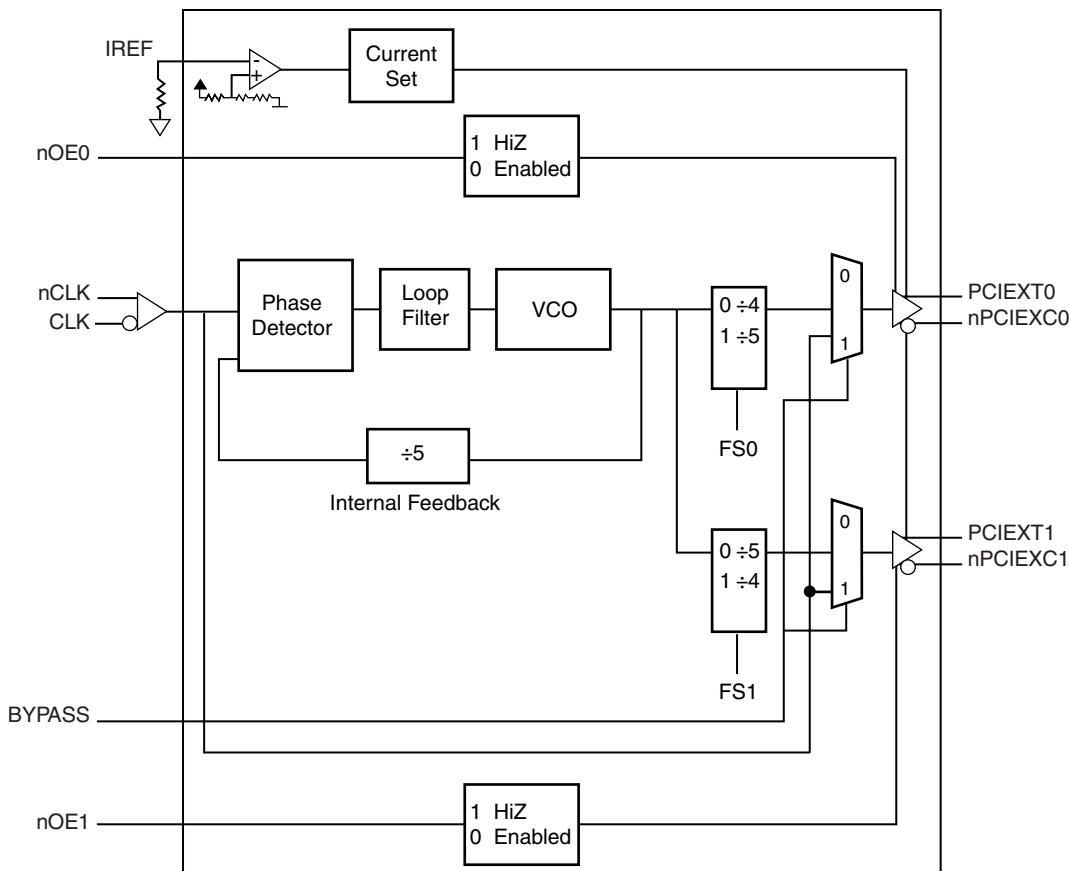

## PIN ASSIGNMENT

PLL_BW	1	20	VDDA
CLK	2	19	BYPASS
nCLK	3	18	IREF
FS0	4	17	FS1
VDD	5	16	VDD
GND	6	15	GND
PCIEXT0	7	14	PCIEXT1
PCIEXC0	8	13	PCIEXC1
VDD	9	12	VDD
nOE0	10	11	nOE1

**ICS9DB202**  
**20-Lead TSSOP**  
 6.50mm x 4.40mm x 0.92  
 package body  
**G Package**  
 Top View

**ICS9DB202**  
**20-Lead, 209-MIL SSOP**  
 5.30mm x 7.20mm x 1.75mm  
 body package  
**F Package**  
 Top View

**TABLE 1. PIN DESCRIPTIONS**

Number	Name	Type		Description
1	PLL_BW	Input	Pullup	Selects PLL Bandwidth input. LVCMOS/LVTTL interface levels.
2	CLK	Input	Pulldown	Non-inverting differential clock input.
3	nCLK	Input	Pullup/ Pulldown	Inverting differential clock input. $V_{DD}/2$ default when left floating.
4	FS0	Input	Pullup	Frequency select pin. LVCMOS/LVTTL interface levels.
5, 9, 12, 16	$V_{DD}$	Power		Core supply pins.
6, 15	GND	Power		Power supply ground.
7, 8	PCIEXT0, PCIEXC0	Output		Differential output pairs. HCSL interface levels.
10, 11	nOE0, nOE1	Input	Pulldown	Output enable. When HIGH, forces outputs to HiZ state. When LOW, enables outputs. LVCMOS/LVTTL interface levels.
13, 14	PCIEXC1, PCIEXT1	Output		Differential output pairs. HCSL interface levels.
17	FS1	Input	Pulldown	Frequency select pin. LVCMOS/LVTTL interface levels.
18	IREF	Input		A fixed precision resistor (475 $\Omega$ ) from this pin to ground provides a reference current used for differential current-mode PCIEX clock outputs.
19	BYPASS	Power	Pulldown	BYPASS pin. When HIGH, bypass mode, when LOW, PLL mode. LVCMOS/LVTTL interface levels.
20	$V_{DDA}$	Power		Analog supply pin. Requires 24 $\Omega$ series resistor.

NOTE: Pullup and Pulldown refer to internal input resistors. See Table 2, Pin Characteristics, for typical values.

**TABLE 2. PIN CHARACTERISTICS**

Symbol	Parameter	Test Conditions	Minimum	Typical	Maximum	Units
$C_{IN}$	Input Capacitance			4		pF
$R_{PULLUP}$	Input Pullup Resistor			51		k $\Omega$
$R_{PULLDOWN}$	Input Pulldown Resistor			51		k $\Omega$

**TABLE 3A. RATIO OF OUTPUT FREQUENCY TO INPUT FREQUENCY FUNCTION TABLE, FS0**

Inputs	Outputs
FS0	PCIEX0
0	5/4
1	1

**TABLE 3B. RATIO OF OUTPUT FREQUENCY TO INPUT FREQUENCY FUNCTION TABLE, FS1**

Inputs	Outputs
FS1	PCIEX1
0	1
1	5/4

**TABLE 3C. BYPASS TABLE**

Inputs	Mode
BYPASS	
0	PLL Mode
1	Bypass Mode (output = inputs)

**TABLE 3D. OUTPUT ENABLE FUNCTION TABLE, nOE0**

Inputs	Outputs
nOE0	PCIEX0
0	Enabled
1	HiZ

**TABLE 3E. OUTPUT ENABLE FUNCTION TABLE, nOE1**

Inputs	Outputs
nOE1	PCIEX1
0	Enabled
1	HiZ

**TABLE 3F. PLL BANDWIDTH TABLE**

Inputs	Bandwidth
PLL_BW	
0	500kHz
1	1MHz

**ABSOLUTE MAXIMUM RATINGS**

Supply Voltage, $V_{DD}$	4.6V
Inputs, $V_I$	-0.5V to $V_{DD} + 0.5V$
Outputs, $V_O$	-0.5V to $V_{DD} + 0.5V$
Package Thermal Impedance, $\theta_{JA}$	
20 Lead TSSOP	73.2°C/W (0 lfpm)
20 Lead SSOP	80.8°C/W (0 lfpm)
Storage Temperature, $T_{STG}$	-65°C to 150°C

NOTE: Stresses beyond those listed under Absolute Maximum Ratings may cause permanent damage to the device. These ratings are stress specifications only. Functional operation of product at these conditions or any conditions beyond those listed in the *DC Characteristics* or *AC Characteristics* is not implied. Exposure to absolute maximum rating conditions for extended periods may affect product reliability.

**TABLE 4A. POWER SUPPLY DC CHARACTERISTICS,  $V_{DD} = V_{DDA} = 3.3V \pm 5\%$ ,  $T_A = 0^\circ C$  TO  $70^\circ C$ ,  $R_{REF} = 475\Omega$**

Symbol	Parameter	Test Conditions	Minimum	Typical	Maximum	Units
$V_{DD}$	Core Supply Voltage		3.135	3.3	3.465	V
$V_{DDA}$	Analog Supply Voltage		3.135	3.3	3.465	V
$I_{DD}$	Power Supply Current				112	mA
$I_{DDA}$	Analog Supply Current				22	mA

**TABLE 4B. LVCMOS / LVTTTL DC CHARACTERISTICS,  $V_{DD} = V_{DDA} = 3.3V \pm 5\%$ ,  $T_A = 0^\circ C$  TO  $70^\circ C$**

Symbol	Parameter	Test Conditions	Minimum	Typical	Maximum	Units
$V_{IH}$	Input High Voltage		2		$V_{DD} + 0.3$	mV
$V_{IL}$	Input Low Voltage		-0.3		0.8	mV
$I_{IH}$	Input High Current	BYPASS, nOE0, nOE1, FS1	$V_{DD} = V_{IN} = 3.465V$		150	$\mu A$
		FS0, PLL_BW			5	
$I_{IL}$	Input Low Current	BYPASS, nOE0, nOE1, FS1	$V_{DD} = 3.465V, V_{IN} = 0V$		-5	$\mu A$
		FS0, PLL_BW			-150	

**TABLE 4C. DIFFERENTIAL DC CHARACTERISTICS,  $V_{DD} = V_{DDA} = 3.3V \pm 5\%$ ,  $T_A = 0^\circ C$  TO  $70^\circ C$ ,  $R_{REF} = 475\Omega$**

Symbol	Parameter	Test Conditions	Minimum	Typical	Maximum	Units
$I_{IH}$	Input High Current	CLK, nCLK	$V_{DD} = V_{IN} = 3.465V$		150	$\mu A$
$I_{IL}$	Input Low Current	CLK, nCLK	$V_{DD} = 3.465V, V_{IN} = 0V$		150	$\mu A$
$V_{PP}$	Peak-to-Peak Input Voltage		0.15		1.3	V
$V_{CMR}$	Common Mode Input Voltage; NOTE 1, 2		GND + 0.5		$V_{DD} - 0.85$	V

NOTE 1: Common mode voltage is defined as  $V_{IH}$ .

NOTE 2: For single ended applications, the maximum input voltage for CLK, nCLK is  $V_{DD} + 0.3V$ .

TABLE 4D. HCSL DC CHARACTERISTICS,  $V_{DD} = V_{DDA} = 3.3V \pm 5\%$ ,  $T_A = 0^\circ C$  TO  $70^\circ C$ ,  $R_{REF} = 475\Omega$

Symbol	Parameter	Test Conditions	Minimum	Typical	Maximum	Units
$I_{OH}$	Output Current		12	14	16	mA
$V_{OH}$	Output High Voltage		610		780	mV
$V_{OL}$	Output Low Voltage				65	mV
$I_{OZ}$	High Impedance Leakage Current		-10		10	$\mu A$
$V_{OX}$	Output Crossover Voltage		250		550	mV

TABLE 5. AC CHARACTERISTICS,  $V_{DD} = V_{DDA} = 3.3V \pm 5\%$ ,  $T_A = 0^\circ C$  TO  $70^\circ C$ ,  $R_{REF} = 475\Omega$

Symbol	Parameter	Test Conditions	Minimum	Typical	Maximum	Units
$f_{MAX}$	Output Frequency				140	MHz
$t_{sk(o)}$	Output Skew; NOTE 1, 2			50	110	ps
$f_{jit(cc)}$	Cycle-to-Cycle Jitter	Outputs @ Different Frequencies			110	ps
		Outputs @ Same Frequencies			50	ps
$f_{jit}(\emptyset)$	RMS Phase Jitter (Random); NOTE 3	Integration Range: 1.5MHz - 22MHz		2.42		ps
$t_R / t_F$	Output Rise/Fall Time	20% to 80%	300		1100	ps
odc	Output Duty Cycle		48		52	%

NOTE 1: Defined as skew between outputs at the same supply voltage and with equal load conditions. Measured at the output differential cross points.

NOTE 2: This parameter is defined in accordance with JEDEC Standard 65.

NOTE 3: Please refer to the Phase Noise Plot following this section.

### TYPICAL PHASE NOISE AT 100MHz

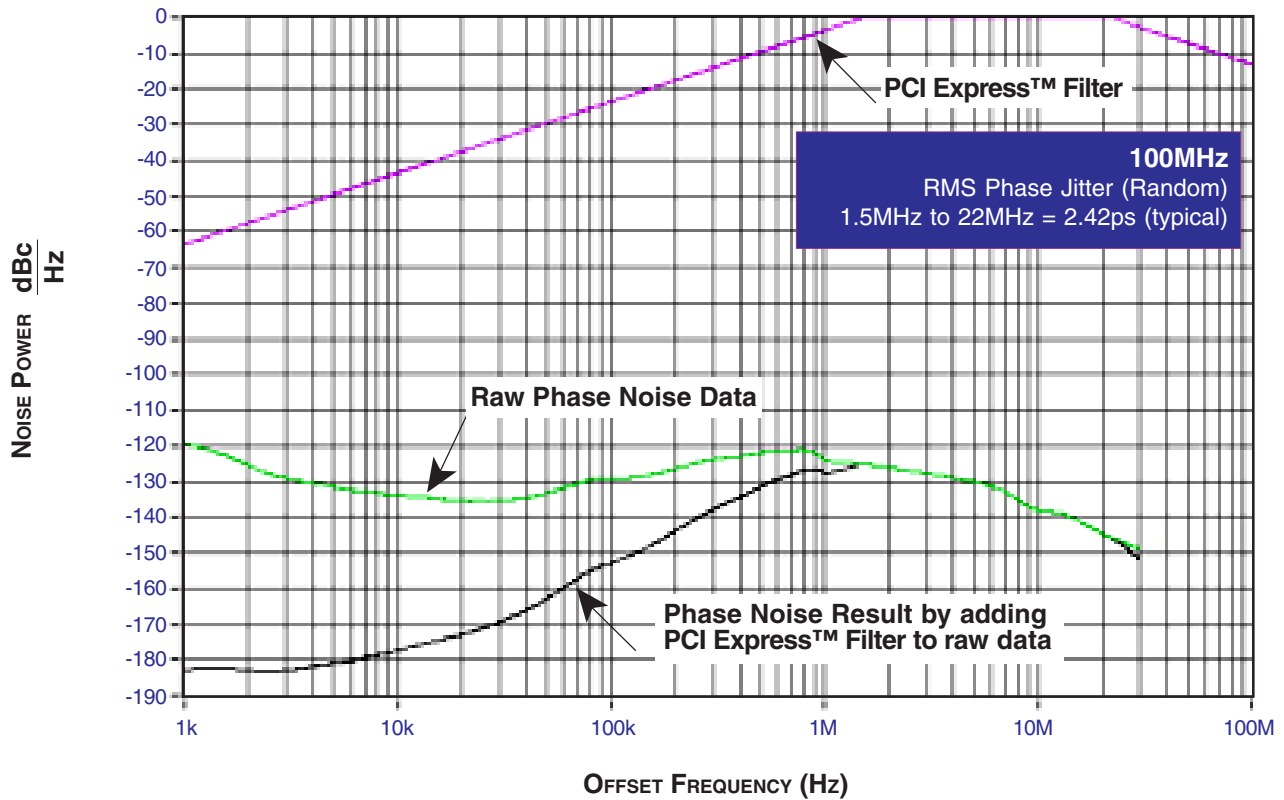

The illustrated phase noise plot was taken using a low phase noise signal generator, the noise floor of the signal generator is less than that of the device under test.

Using this configuration allows one to see the true spectral purity or phase noise performance of the PLL in the device under test.

Due to the tracking ability of a PLL, it will track the input signal up to its loop bandwidth. Therefore, if the input phase noise is greater than that of the PLL, it will increase the output phase noise performance of the device. It is recommended that the phase noise performance of the input is verified in order to achieve the above phase noise performance.

## PARAMETER MEASUREMENT INFORMATION

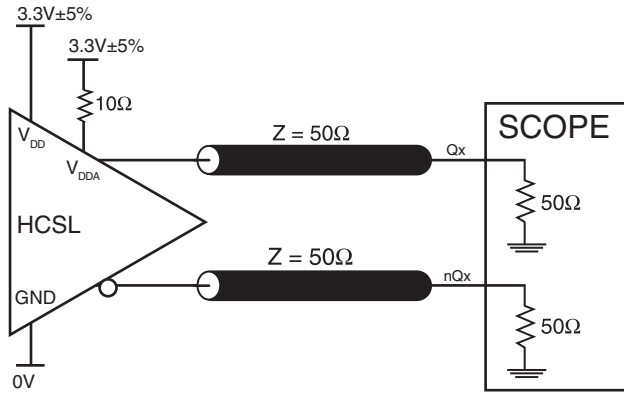

3.3V HCSL OUTPUT LOAD AC TEST CIRCUIT

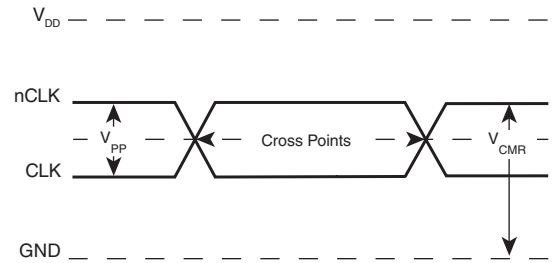

DIFFERENTIAL INPUT LEVEL

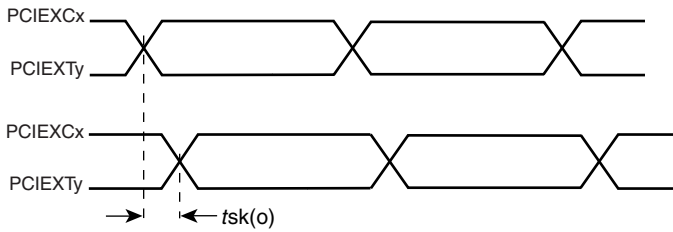

OUTPUT SKEW

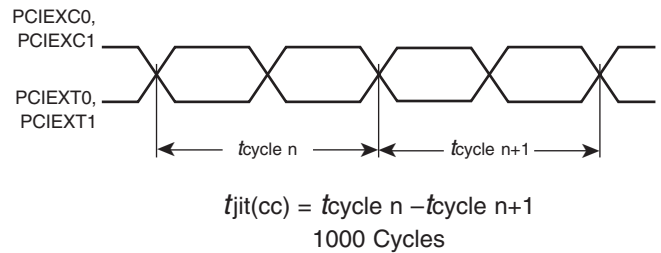

CYCLE-TO-CYCLE JITTER

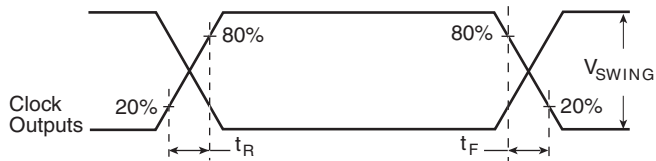

HCSL OUTPUT RISE/FALL TIME

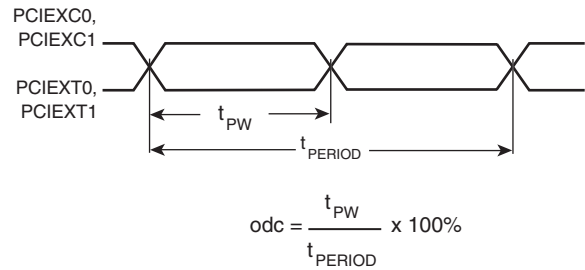

OUTPUT DUTY CYCLE/PULSE WIDTH/PERIOD

## APPLICATION INFORMATION

### POWER SUPPLY FILTERING TECHNIQUES

As in any high speed analog circuitry, the power supply pins are vulnerable to random noise. The ICS9DB202 provides separate power supplies to isolate any high switching noise from the outputs to the internal PLL.  $V_{DD}$  and  $V_{DDA}$  should be individually connected to the power supply plane through vias, and bypass capacitors should be used for each pin. To achieve optimum jitter performance, power supply isolation is required. *Figure 1* illustrates how a  $24\Omega$  resistor along with a  $10\mu\text{F}$  and a  $.01\mu\text{F}$  bypass capacitor should be connected to each  $V_{DDA}$  pin. The  $10\Omega$  resistor can also be replaced by a ferrite bead.

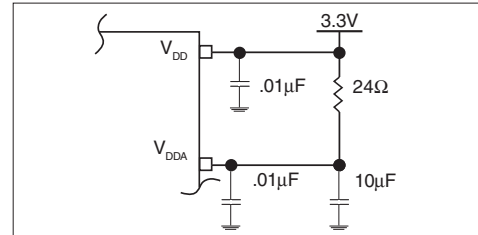

FIGURE 1. POWER SUPPLY FILTERING

### WIRING THE DIFFERENTIAL INPUT TO ACCEPT SINGLE ENDED LEVELS

*Figure 2* shows how the differential input can be wired to accept single ended levels. The reference voltage  $V_{REF} = V_{DD}/2$  is generated by the bias resistors R1, R2 and C1. This bias circuit should be located as close as possible to the input pin. The ratio

of R1 and R2 might need to be adjusted to position the  $V_{REF}$  in the center of the input voltage swing. For example, if the input clock swing is only 2.5V and  $V_{DD} = 3.3\text{V}$ ,  $V_{REF}$  should be 1.25V and  $R2/R1 = 0.609$ .

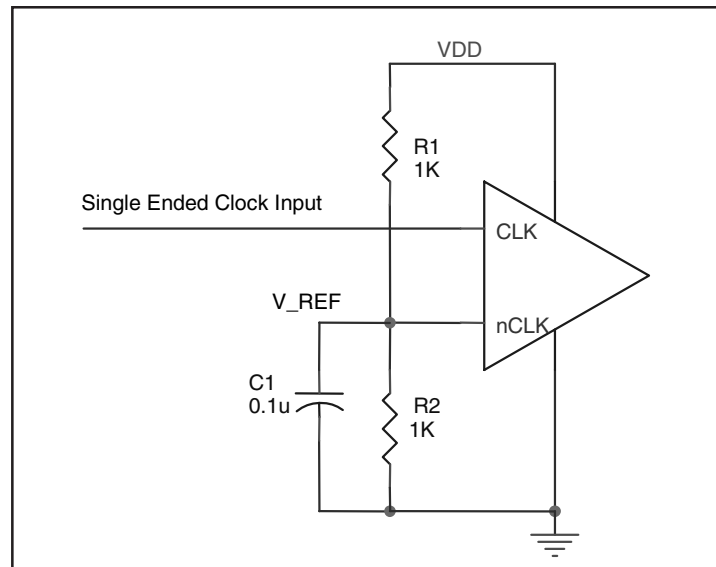
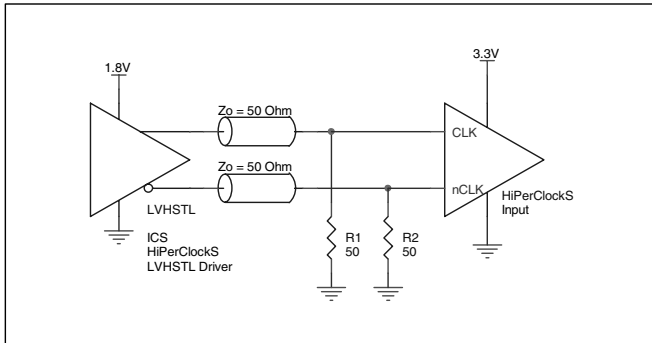

FIGURE 2. SINGLE ENDED SIGNAL DRIVING DIFFERENTIAL INPUT

## DIFFERENTIAL CLOCK INPUT INTERFACE

The CLK /nCLK accepts LVDS, LVPECL, LVHSTL, SSTL, HCSTL and other differential signals. Both  $V_{SWING}$  and  $V_{OH}$  must meet the  $V_{PP}$  and  $V_{CMR}$  input requirements. Figures 3A to 3D show interface examples for the HiPerClockS CLK/nCLK input driven by the most common driver types. The input interfaces suggested here are

examples only. Please consult with the vendor of the driver component to confirm the driver termination requirements. For example in *Figure 3A*, the input termination applies for ICS HiPerClockS LVHSTL drivers. If you are using an LVHSTL driver from another vendor, use their termination recommendation.



**FIGURE 3A. HiPerClockS CLK/nCLK INPUT DRIVEN BY ICS HiPerClockS LVHSTL DRIVER**

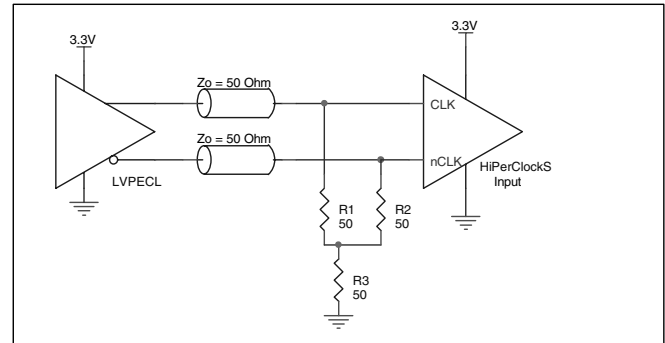

**FIGURE 3B. HiPerClockS CLK/nCLK INPUT DRIVEN BY 3.3V LVPECL DRIVER**

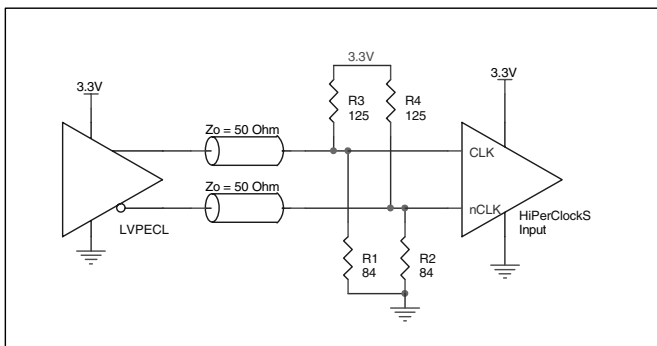

**FIGURE 3C. HiPerClockS CLK/nCLK INPUT DRIVEN BY 3.3V LVPECL DRIVER**

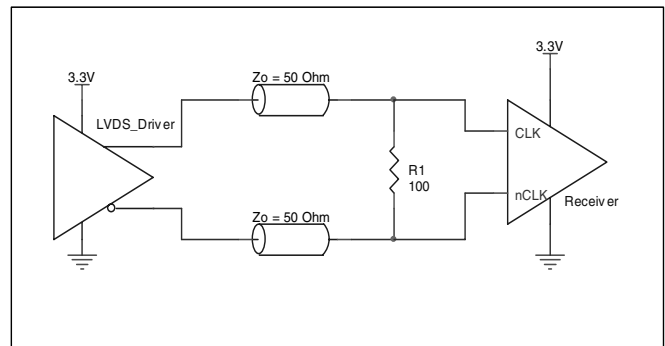

**FIGURE 3D. HiPerClockS CLK/nCLK INPUT DRIVEN BY 3.3V LVDS DRIVER**

## RECOMMENDATIONS FOR UNUSED INPUT AND OUTPUT PINS

### INPUTS:

#### LVC MOS CONTROL PINS:

All control pins have internal pull-ups or pull-downs; additional resistance is not required but can be added for additional protection. A 1k $\Omega$  resistor can be used.

### OUTPUTS:

#### HCSTL OUTPUT

All unused HCSTL outputs can be left floating. We recommend that there is no trace attached. Both sides of the differential output pair should either be left floating or terminated.



## RELIABILITY INFORMATION

TABLE 6A.  $\theta_{JA}$  vs. AIR FLOW TABLE FOR 20 LEAD TSSOP PACKAGE

$\theta_{JA}$ by Velocity (Linear Feet per Minute)			
	0	200	500
Single-Layer PCB, JEDEC Standard Test Boards	114.5°C/W	98°C/W	88°C/W
Multi-Layer PCB, JEDEC Standard Test Boards	73.2°C/W	66.6°C/W	63.5°C/W

**NOTE:** Most modern PCB designs use multi-layered boards. The data in the second row pertains to most designs.

TABLE 6B.  $\theta_{JA}$  vs. AIR FLOW TABLE FOR 20 LEAD SSOP PACKAGE

$\theta_{JA}$ by Velocity (Linear Feet per Minute)			
	0	200	500
Multi-Layer PCB, JEDEC Standard Test Boards	80.8°C/W	73.2°C/W	69.2°C/W

### TRANSISTOR COUNT

The transistor count for ICS9DB202 is: 2471

PACKAGE OUTLINE - G SUFFIX FOR 20 LEAD TSSOP

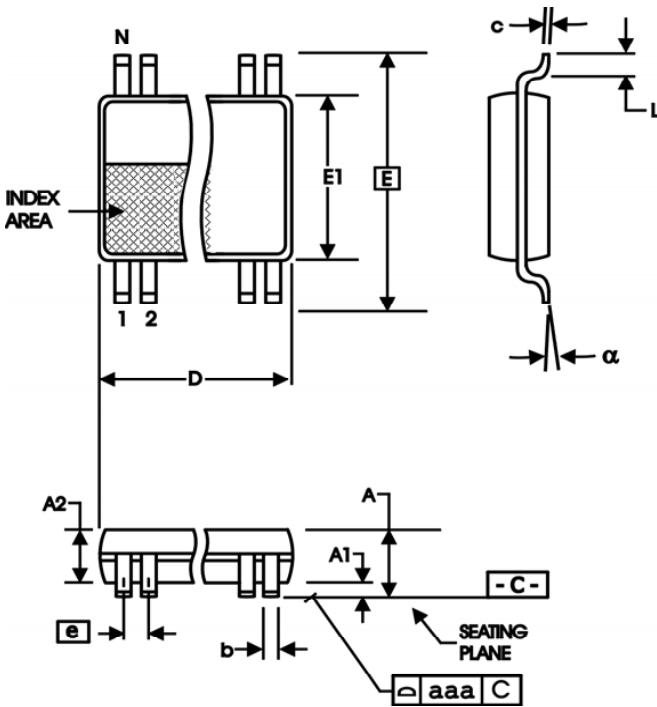

PACKAGE OUTLINE - F SUFFIX FOR 20 LEAD SSOP

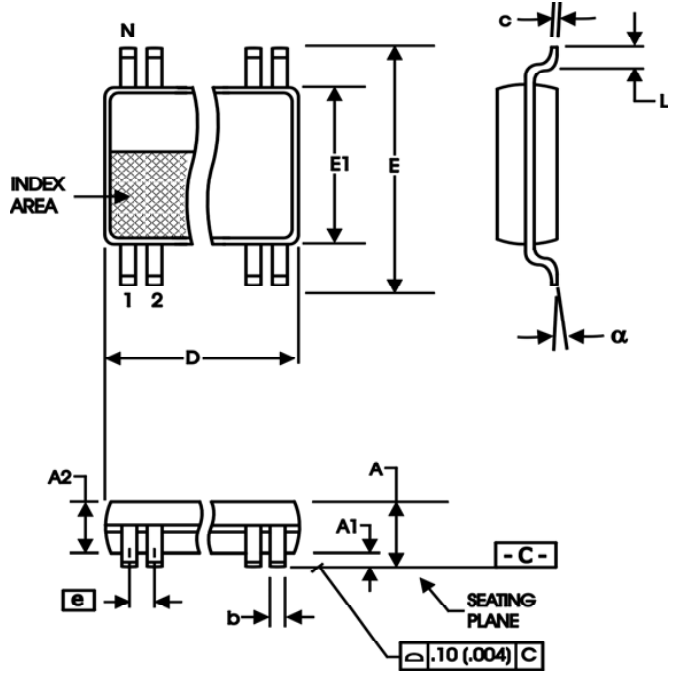

TABLE 6A. PACKAGE DIMENSIONS

SYMBOL	Millimeters	
	Minimum	Maximum
N	20	
A	--	1.20
A1	0.05	0.15
A2	0.80	1.05
b	0.19	0.30
c	0.09	0.20
D	6.40	6.60
E	6.40 BASIC	
E1	4.30	4.50
e	0.65 BASIC	
L	0.45	0.75
$\alpha$	0°	8°
aaa	--	0.10

Reference Document: JEDEC Publication 95, MO-153

TABLE 6B. PACKAGE DIMENSIONS

SYMBOL	Millimeters	
	Minimum	Maximum
N	20	
A	--	2.0
A1	0.05	--
A2	1.65	1.85
b	0.22	0.38
c	0.09	0.25
D	6.90	7.50
E	7.40	8.20
E1	5.0	5.60
e	0.65 BASIC	
L	0.55	0.95
$\alpha$	0°	8°

Reference Document: JEDEC Publication 95, MO-150

**TABLE 7. ORDERING INFORMATION**

Part/Order Number	Marking	Package	Shipping Packaging	Temperature
ICS9DB202CG	ICS9DB202CG	20 Lead TSSOP	Tube	0°C to 70°C
ICS9DB202CGT	ICS9DB202CG	20 Lead TSSOP	2500 Tape & Reel	0°C to 70°C
ICS9DB202CGLF	ICS9DB202CGL	20 Lead "Lead-Free" TSSOP	Tube	0°C to 70°C
ICS9DB202CGLFT	ICS9DB202CGL	20 Lead "Lead-Free" TSSOP	2500 Tape & Reel	0°C to 70°C
ICS9DB202CF	ICS9DB202CF	20 Lead SSOP	Tube	0°C to 70°C
ICS9DB202CFT	ICS9DB202CF	20 Lead SSOP	1000 Tape & Reel	0°C to 70°C
ICS9DB202CFLF	ICS9DB202CFLF	20 Lead "Lead-Free" SSOP	Tube	0°C to 70°C
ICS9DB202CFLFT	ICS9DB202CFLF	20 Lead "Lead-Free" SSOP	1000 Tape & Reel	0°C to 70°C

NOTE: Parts that are ordered with an "LF" suffix to the part number are the Pb-Free configuration and are RoHS compliant.

While the information presented herein has been checked for both accuracy and reliability, Integrated Device Technology, Incorporated (IDT) assumes no responsibility for either its use or for infringement of any patents or other rights of third parties, which would result from its use. No other circuits, patents, or licenses are implied. This product is intended for use in normal commercial and industrial applications. Any other applications such as those requiring high reliability or other extraordinary environmental requirements are not recommended without additional processing by IDT. IDT reserves the right to change any circuitry or specifications without notice. IDT does not authorize or warrant any IDT product for use in life support devices or critical medical instruments.

## REVISION HISTORY SHEET

Rev	Table	Page	Description of Change	Date
B	T4D	4	HCSL Table -adjusted $V_{OH}$ min from 680mV to 610mV and added $V_{OH}$ max.	12/21/04
B	T7	6	Updated HCSL Output Load AC Test Circuit Diagram.	3/8/06
		8	Application Information - added <i>Recommendations for Unused Input and Output Pins.</i>	
		11	Ordering Information Table - added lead-free note.	
B	T4D	4	HCSL DC Characteristics - corrected units for $V_{OH}$ & $V_{OL}$ from V to mV.	5/26/06
B		1	Feature Section - added Input Frequency Range and VCO Range.	7/14/06

Innovate with IDT and accelerate your future networks. Contact:

**www.IDT.com**

**For Sales**

800-345-7015  
408-284-8200  
Fax: 408-284-2775

**For Tech Support**

netcom@idt.com  
480-763-2056

---

**Corporate Headquarters**

Integrated Device Technology, Inc.  
6024 Silver Creek Valley Road  
San Jose, CA 95138  
United States  
800 345 7015  
+408 284 8200 (outside U.S.)

**Asia Pacific and Japan**

Integrated Device Technology  
Singapore (1997) Pte. Ltd.  
Reg. No. 199707558G  
435 Orchard Road  
#20-03 Wisma Atria  
Singapore 238877  
+65 6 887 5505

**Europe**

IDT Europe, Limited  
321 Kingston Road  
Leatherhead, Surrey  
KT22 7TU  
England  
+44 (0) 1372 363 339  
Fax: +44 (0) 1372 378851

